

This Manual Was
Supplied
By Traceys-Bits
www.ebay.co.uk





ZZR 1400
ZZR1400 ABS
Ninja ZX-14



Motorcycle Service Manual

Quick Reference Guide

General Information	1
Periodic Maintenance	2
Fuel System (DFI)	3
Cooling System	4
Engine Top End	5
Clutch	6
Engine Lubrication System	7
Engine Removal/Installation	8
Crankshaft/Transmission	9
Wheels/Tires	10
Final Drive	11
Brakes	12
Suspension	13
Steering	14
Frame	15
Electrical System	16
Appendix	17

This quick reference guide will assist you in locating a desired topic or procedure.

- Bend the pages back to match the black tab of the desired chapter number with the black tab on the edge at each table of contents page.
- Refer to the sectional table of contents for the exact pages to locate the specific topic required.



**ZZR 1400
ZZR1400 ABS
Ninja ZX-14**

Motorcycle Service Manual

All rights reserved. No parts of this publication may be reproduced, stored in a retrieval system, or transmitted in any form or by any means, electronic mechanical photocopying, recording or otherwise, without the prior written permission of Quality Division/Consumer Products & Machinery Company/Kawasaki Heavy Industries, Ltd., Japan.

No liability can be accepted for any inaccuracies or omissions in this publication, although every possible care has been taken to make it as complete and accurate as possible.

The right is reserved to make changes at any time without prior notice and without incurring an obligation to make such changes to products manufactured previously. See your Motorcycle dealer for the latest information on product improvements incorporated after this publication.

All information contained in this publication is based on the latest product information available at the time of publication. Illustrations and photographs in this publication are intended for reference use only and may not depict actual model component parts.

LIST OF ABBREVIATIONS

A	ampere(s)	lb	pound(s)
ABDC	after bottom dead center	m	meter(s)
AC	alternating current	min	minute(s)
ATDC	after top dead center	N	newton(s)
BBDC	before bottom dead center	Pa	pascal(s)
BDC	bottom dead center	PS	horsepower
BTDC	before top dead center	psi	pound(s) per square inch
°C	degree(s) Celsius	r	revolution
DC	direct current	rpm	revolution(s) per minute
F	farad(s)	TDC	top dead center
°F	degree(s) Fahrenheit	TIR	total indicator reading
ft	foot, feet	V	volt(s)
g	gram(s)	W	watt(s)
h	hour(s)	Ω	ohm(s)
L	liter(s)		

COUNTRY AND AREA CODES

AT	Austria	FR	France
AU	Australia	GB	United Kingdom
CA	Canada	MY	Malaysia
CAL	California	US	United States
CH	Switzerland	WVTA	Whole Vehicle Type Approval
DE	Germany		

EMISSION CONTROL INFORMATION

To protect the environment in which we all live, Kawasaki has incorporated crankcase emission (1) and exhaust emission (2) control systems in compliance with applicable regulations of the United States Environmental Protection Agency and California Air Resources Board. Additionally, Kawasaki has incorporated an evaporative emission control system (3) in compliance with applicable regulations of the California Air Resources Board on vehicles sold in California only.

1. Crankcase Emission Control System

This system eliminates the release of crankcase vapors into the atmosphere. Instead, the vapors are routed through an oil separator to the inlet side of the engine. While the engine is operating, the vapors are drawn into combustion chamber, where they are burned along with the fuel and air supplied by the fuel injection system.

2. Exhaust Emission Control System

This system reduces the amount of pollutants discharged into the atmosphere by the exhaust of this motorcycle. The fuel, ignition, and exhaust systems of this motorcycle have been carefully designed and constructed to ensure an efficient engine with low exhaust pollutant levels.

The exhaust system of this model motorcycle manufactured primarily for sale in California includes a catalytic converter system.

3. Evaporative Emission Control System

Vapors caused by fuel evaporation in the fuel system are not vented into the atmosphere. Instead, fuel vapors are routed into the running engine to be burned, or stored in a canister when the engine is stopped. Liquid fuel is caught by a vapor separator and returned to the fuel tank.

The Clean Air Act, which is the Federal law covering motor vehicle pollution, contains what is commonly referred to as the Act's "tampering provisions".

"Sec. 203(a) The following acts and the causing thereof are prohibited...

(3)(A) for any person to remove or render inoperative any device or element of design installed on or in a motor vehicle or motor vehicle engine in compliance with regulations under this title prior to its sale and delivery to the ultimate purchaser, or for any manufacturer or dealer knowingly to remove or render inoperative any such device or element of design after such sale and delivery to the ultimate purchaser.

(3)(B) for any person engaged in the business of repairing, servicing, selling, leasing, or trading motor vehicles or motor vehicle engines, or who operates a fleet of motor vehicles knowingly to remove or render inoperative any device or element of design installed on or in a motor vehicle or motor vehicle engine in compliance with regulations under this title following its sale and delivery to the ultimate purchaser..."

NOTE

○The phrase "remove or render inoperative any device or element of design" has been generally interpreted as follows.

1. Tampering does not include the temporary removal or rendering inoperative of devices or elements of design in order to perform maintenance.
2. Tampering could include.
 - a. Maladjustment of vehicle components such that the emission standards are exceeded.
 - b. Use of replacement parts or accessories which adversely affect the performance or durability of the motorcycle.
 - c. Addition of components or accessories that result in the vehicle exceeding the standards.
 - d. Permanently removing, disconnecting, or rendering inoperative any component or element of design of the emission control systems.

WE RECOMMEND THAT ALL DEALERS OBSERVE THESE PROVISIONS OF FEDERAL LAW, THE VIOLATION OF WHICH IS PUNISHABLE BY CIVIL PENALTIES NOT EXCEEDING \$10 000 PER VIOLATION.

TAMPERING WITH NOISE CONTROL SYSTEM PROHIBITED

Federal law prohibits the following acts or the causing thereof. (1) The removal or rendering inoperative by any person other than for purposes of maintenance, repair, or replacement, of any device or element of design incorporated into any new vehicle for the purpose of noise control prior to its sale or delivery to the ultimate purchaser or while it is in use, or (2) the use of the vehicle after such device or element of design has been removed or rendered inoperative by any person.

Among those acts presumed to constitute tampering are the acts listed below.

- Replacement of the original exhaust system or muffler with a component not in compliance with Federal regulations.
- Removal of the muffler(s) or any internal portion of the muffler(s).
- Removal of the air box or air box cover.
- Modifications to the muffler(s) or air inlet system by cutting, drilling, or other means if such modifications result in increased noise levels.

Foreword

This manual is designed primarily for use by trained mechanics in a properly equipped shop. However, it contains enough detail and basic information to make it useful to the owner who desires to perform his own basic maintenance and repair work. A basic knowledge of mechanics, the proper use of tools, and workshop procedures must be understood in order to carry out maintenance and repair satisfactorily. Whenever the owner has insufficient experience or doubts his ability to do the work, all adjustments, maintenance, and repair should be carried out only by qualified mechanics.

In order to perform the work efficiently and to avoid costly mistakes, read the text, thoroughly familiarize yourself with the procedures before starting work, and then do the work carefully in a clean area. Whenever special tools or equipment are specified, do not use makeshift tools or equipment. Precision measurements can only be made if the proper instruments are used, and the use of substitute tools may adversely affect safe operation.

For the duration of the warranty period, we recommend that all repairs and scheduled maintenance be performed in accordance with this service manual. Any owner maintenance or repair procedure not performed in accordance with this manual may void the warranty.

To get the longest life out of your vehicle.

- Follow the Periodic Maintenance Chart in the Service Manual.
- Be alert for problems and non-scheduled maintenance.
- Use proper tools and genuine Kawasaki Motorcycle parts. Special tools, gauges, and testers that are necessary when servicing Kawasaki motorcycles are introduced by the Service Manual. Genuine parts provided as spare parts are listed in the Parts Catalog.
- Follow the procedures in this manual carefully. Don't take shortcuts.
- Remember to keep complete records of maintenance and repair with dates and any new parts installed.

How to Use This Manual

In this manual, the product is divided into its major systems and these systems make up the manual's chapters. The Quick Reference

Guide shows you all of the product's system and assists in locating their chapters. Each chapter in turn has its own comprehensive Table of Contents.

For example, if you want ignition coil information, use the Quick Reference Guide to locate the Electrical System chapter. Then, use the Table of Contents on the first page of the chapter to find the Ignition Coil section.

Whenever you see these WARNING and CAUTION symbols, heed their instructions! Always follow safe operating and maintenance practices.

WARNING

This warning symbol identifies special instructions or procedures which, if not correctly followed, could result in personal injury, or loss of life.

CAUTION

This caution symbol identifies special instructions or procedures which, if not strictly observed, could result in damage to or destruction of equipment.

This manual contains four more symbols (in addition to WARNING and CAUTION) which will help you distinguish different types of information.

NOTE

○ *This note symbol indicates points of particular interest for more efficient and convenient operation.*

- Indicates a procedural step or work to be done.
- Indicates a procedural sub-step or how to do the work of the procedural step it follows. It also precedes the text of a NOTE.
- ★ Indicates a conditional step or what action to take based on the results of the test or inspection in the procedural step or sub-step it follows.

In most chapters an exploded view illustration of the system components follows the Table of Contents. In these illustrations you will find the instructions indicating which parts require specified tightening torque, oil, grease or a locking agent during assembly.

General Information

Table of Contents

Before Servicing	1-2
Model Identification.....	1-7
General Specifications.....	1-12
Technical Information-CAN (Controller Area Network) Communication System.....	1-15
Unit Conversion Table	1-18

1-2 GENERAL INFORMATION

Before Servicing

Before starting to perform an inspection service or carry out a disassembly and reassembly operation on a motorcycle, read the precautions given below. To facilitate actual operations, notes, illustrations, photographs, cautions, and detailed descriptions have been included in each chapter wherever necessary. This section explains the items that require particular attention during the removal and reinstallation or disassembly and reassembly of general parts.

Especially note the following.

Battery Ground

Before completing any service on the motorcycle, disconnect the battery cables from the battery to prevent the engine from accidentally turning over. Disconnect the ground cable (–) first and then the positive (+). When completed with the service, first connect the positive (+) cable to the positive (+) terminal of the battery then the negative (–) cable to the negative terminal.

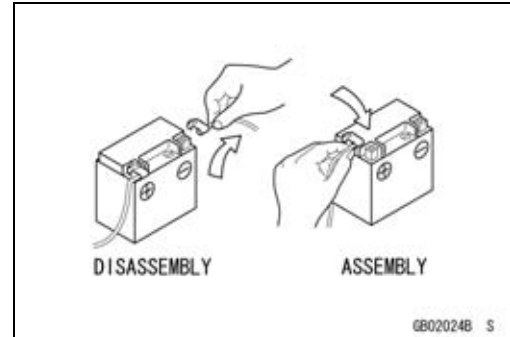

Edges of Parts

Lift large or heavy parts wearing gloves to prevent injury from possible sharp edges on the parts.

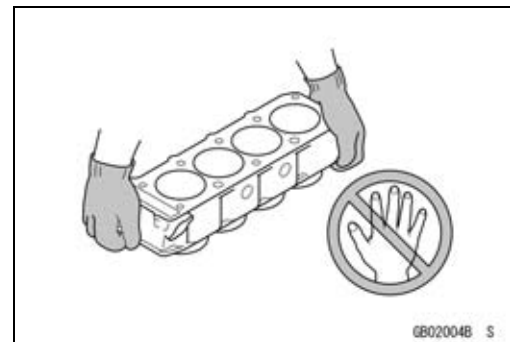

Solvent

Use a high-flash point solvent when cleaning parts. High-flash point solvent should be used according to directions of the solvent manufacturer.

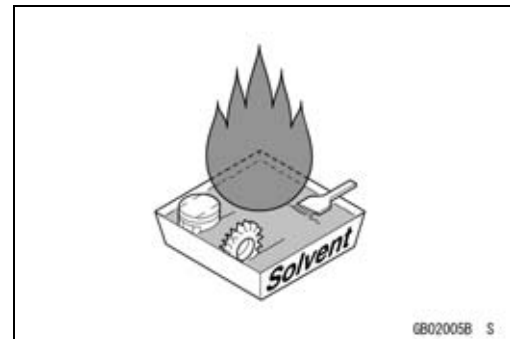

Cleaning vehicle before disassembly

Clean the vehicle thoroughly before disassembly. Dirt or other foreign materials entering into sealed areas during vehicle disassembly can cause excessive wear and decrease performance of the vehicle.

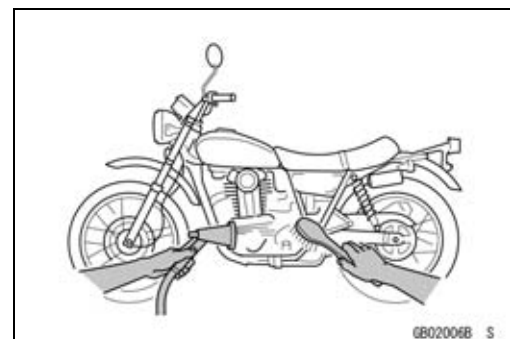

Before Servicing

Arrangement and Cleaning of Removed Parts

Disassembled parts are easy to confuse. Arrange the parts according to the order the parts were disassembled and clean the parts in order prior to assembly.

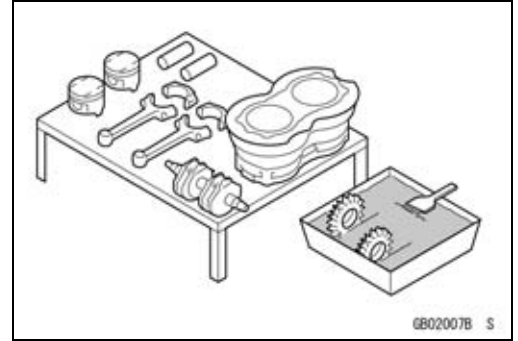

GB02007B S

Storage of Removed Parts

After all the parts including subassembly parts have been cleaned, store the parts in a clean area. Put a clean cloth or plastic sheet over the parts to protect from any foreign materials that may collect before re-assembly.

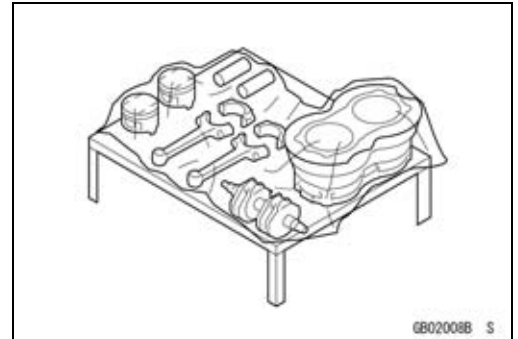

GB02008B S

Inspection

Reuse of worn or damaged parts may lead to serious accident. Visually inspect removed parts for corrosion, discoloration, or other damage. Refer to the appropriate sections of this manual for service limits on individual parts. Replace the parts if any damage has been found or if the part is beyond its service limit.

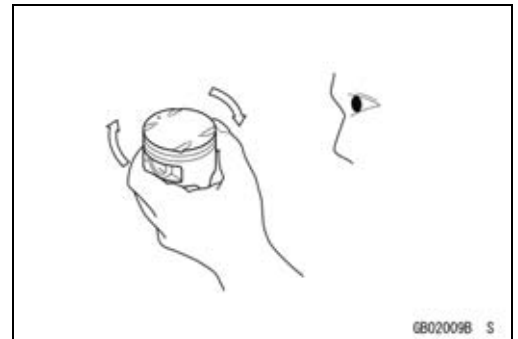

GB02009B S

Replacement Parts

Replacement Parts must be KAWASAKI genuine or recommended by KAWASAKI. Gaskets, O-rings, oil seals, grease seals, circlips or cotter pins must be replaced with new ones whenever disassembled.

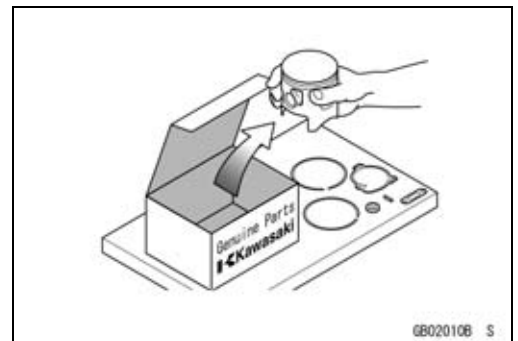

GB02010B S

Assembly Order

In most cases assembly order is the reverse of disassembly, however, if assembly order is provided in this Service Manual, follow the procedures given.

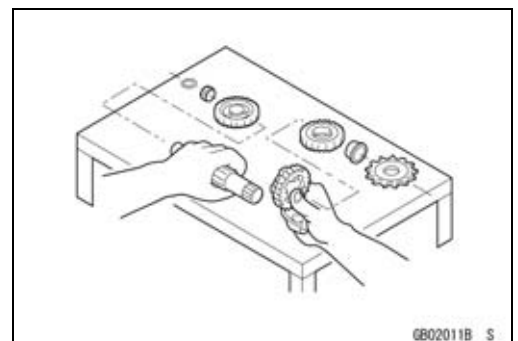

GB02011B S

1-4 GENERAL INFORMATION

Before Servicing

Tightening Sequence

Generally, when installing a part with several bolts, nuts, or screws, start them all in their holes and tighten them to a snug fit. Then tighten them according to the specified sequence to prevent case warpage or deformation which can lead to malfunction. Conversely when loosening the bolts, nuts, or screws, first loosen all of them by about a quarter turn and then remove them. If the specified tightening sequence is not indicated, tighten the fasteners alternating diagonally.

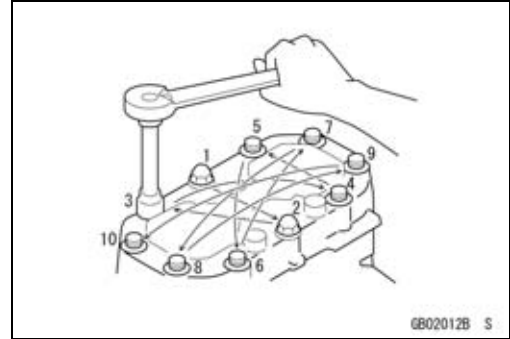

Tightening Torque

Incorrect torque applied to a bolt, nut, or screw may lead to serious damage. Tighten fasteners to the specified torque using a good quality torque wrench.

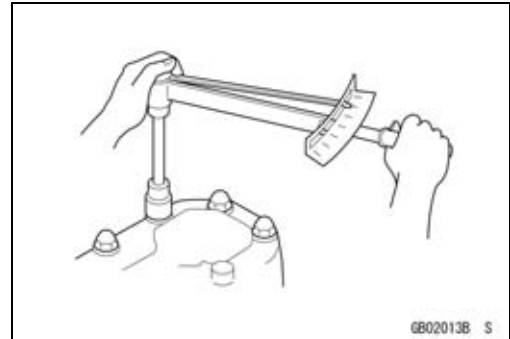

Force

Use common sense during disassembly and assembly, excessive force can cause expensive or hard to repair damage. When necessary, remove screws that have a non-permanent locking agent applied using an impact driver. Use a plastic-faced mallet whenever tapping is necessary.

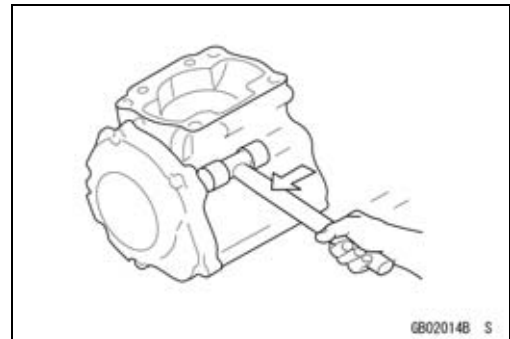

Gasket, O-ring

Hardening, shrinkage, or damage of both gaskets and O-rings after disassembly can reduce sealing performance. Remove the old gaskets and clean the sealing surfaces thoroughly so that no gasket material or other material remains. Install the new gaskets and replace the used O-rings when re-assembling.

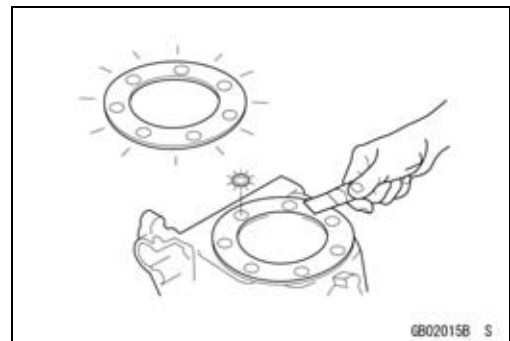

Liquid Gasket, Non-permanent Locking Agent

For applications that require Liquid Gasket or a Non-permanent Locking Agent, clean the surfaces so that no oil residue remains before applying liquid gasket or non-permanent locking agent. Do not apply them excessively. Excessive application can clog oil passages and cause serious damage.



Before Servicing

Press

For items such as bearings or oil seals that must be pressed into place, apply small amount of oil to the contact area. Be sure to maintain proper alignment and use smooth movements when installing.

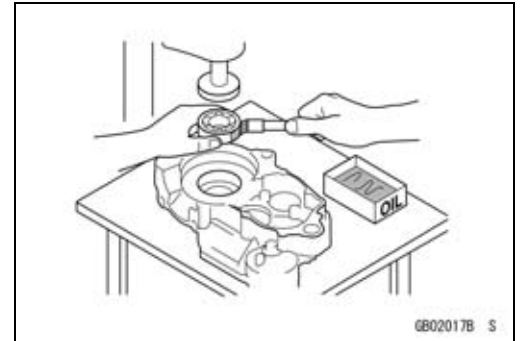

Ball Bearing and Needle Bearing

Do not remove pressed ball or needle unless removal is absolutely necessary. Replace with new ones whenever removed. Press bearings with the manufacturer and size marks facing out. Press the bearing into place by putting pressure on the correct bearing race as shown.

Pressing the incorrect race can cause pressure between the inner and outer race and result in bearing damage.

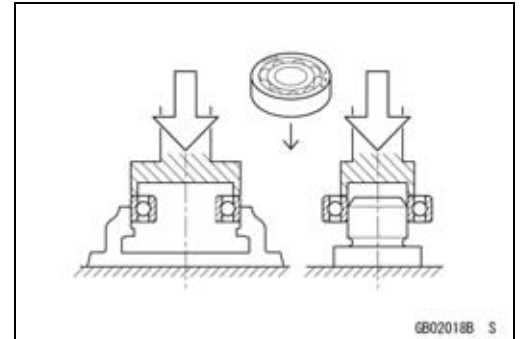

Oil Seal, Grease Seal

Do not remove pressed oil or grease seals unless removal is necessary. Replace with new ones whenever removed. Press new oil seals with manufacture and size marks facing out. Make sure the seal is aligned properly when installing.

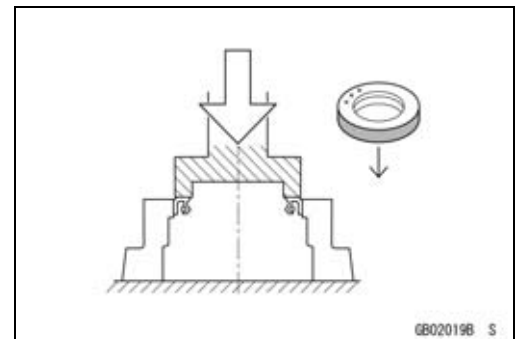

Apply specified grease to the lip of seal before installing the seal.

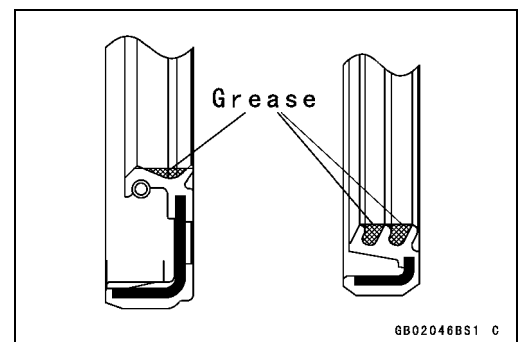

Circlips, Cotter Pins

Replace the circlips or cotter pins that were removed with new ones. Take care not to open the clip excessively when installing to prevent deformation.

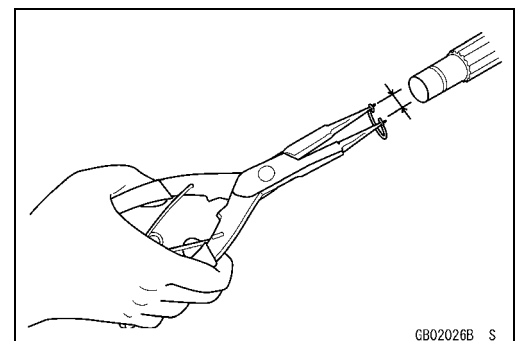

1-6 GENERAL INFORMATION

Before Servicing

Lubrication

It is important to lubricate rotating or sliding parts during assembly to minimize wear during initial operation. Lubrication points are called out throughout this manual, apply the specific oil or grease as specified.

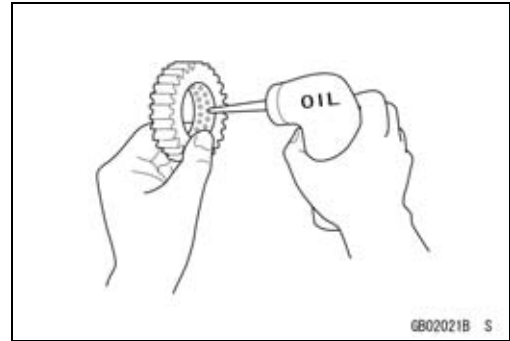

Direction of Engine Rotation

When rotating the crankshaft by hand, the free play amount of rotating direction will affect the adjustment. Rotate the crankshaft to positive direction (clockwise viewed from output side).

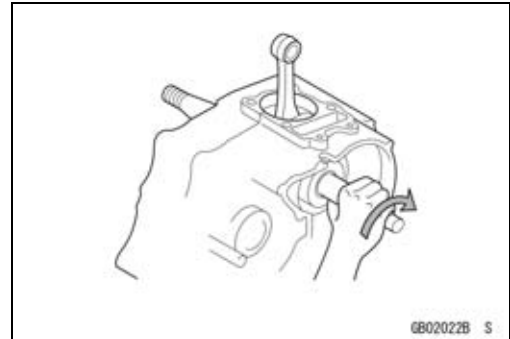

Electrical Wires

A two-color wire is identified first by the primary color and then the stripe color. Unless instructed otherwise, electrical wires must be connected to those of the same color.

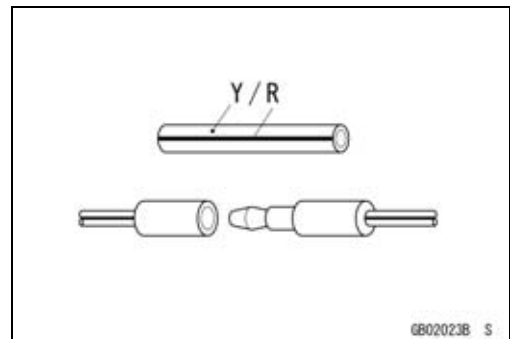

Instrument

Use a meter that has enough accuracy for an accurate measurement. Read the manufacturer's instructions thoroughly before using the meter. Incorrect values may lead to improper adjustments.

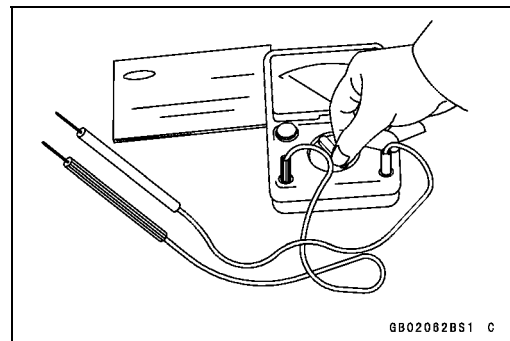

Model Identification

ZX1400A6F (Europe) Left Side View



ZX1400A6F (Europe) Right Side View



Frame Number

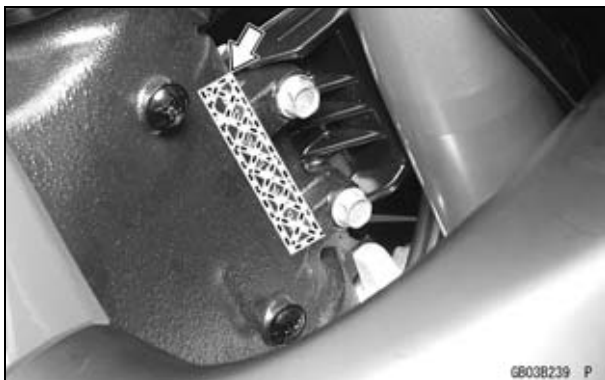

Engine Number



1-8 GENERAL INFORMATION

Model Identification

ZX1400A6F (United States and Canada) Left Side View



6B03B241 P

ZX1400A6F (United States and Canada) Right Side View



6B03B242 P

Model Identification

ZX1400A6F (Malaysia) Left Side View



ZX1400A6F (Malaysia) Right Side View



1-10 GENERAL INFORMATION

Model Identification

ZX1400B6F (Europe) Left Side View



ZX1400B6F (Europe) Right Side View



Model Identification

ZX1400B6F (Malaysia) Left Side View



ZX1400B6F (Malaysia) Right Side View



1-12 GENERAL INFORMATION

General Specifications

Items	ZX1400A6F, ZX1400B6F
Dimensions	
Overall Length	2 170 mm (85.4 in.)
Overall Width	760 mm (29.9 in.)
Overall Height	1 170 mm (46.1 in.)
Wheelbase	1 460 mm (57.4 in.)
Road Clearance	125 mm (4.9 in.)
Seat Height	800 mm (31.5 in.)
Dry Mass:	
ZX1400A6F	215 kg (474 lb)
ZX1400B6F	218 kg (481 lb)
Curb Mass:	
Front	
ZX1400A6F	125 kg (276 lb)
ZX1400B6F	126 kg (278 lb)
Rear	
ZX1400A6F	127 kg (280 lb)
ZX1400B6F	129 kg (284 lb)
Fuel Tank Capacity	22 L (5.8 US gal)
Performance	
Minimum Turning Radius	3.1 m (10.2 ft)
Engine	
Type	4-stroke, DOHC, 4-cylinder
Cooling System	Liquid-cooled
Bore and Stroke	84.0 × 61.0 mm (3.3 × 2.4 in.)
Displacement	1 352 cm ³ (82.5 cu in.)
Compression Ratio	12.0 : 1
Maximum Horsepower	140.0 kW (190 PS) @9 500 r/min (rpm), (FR) 78.2 kW (106 PS) @8 500 r/min (rpm), (MY) 132.6 kW (180 PS) @9 000 r/min (rpm), (CA, CAL, US) – – –
Maximum Torque	154 N·m (15.7 kgf·m, 114 ft·lb) @7 500 r/min (rpm), (FR) 114 N·m (11.6 kgf·m, 84 ft·lb) @4 500 r/min (rpm), (MY) 147.4 N·m (15.0 kgf·m, 109 ft·lb) @7 500 r/min (rpm), (CA), (CAL), (US) – – –
Carburetion System	FI (Fuel injection), MIKUNI 44EIDW × 4
Starting System	Electric starter
Ignition System	Battery and coil (transistorized)
Timing Advance	Electronically advanced (digital igniter in ECU)
Ignition Timing	From 10° BTDC @1 100 r/min (rpm)
Spark Plug	NGK CR9EIA-9
Cylinder Numbering Method	Left to right, 1-2-3-4
Firing Order	1-2-4-3

General Specifications

Items	ZX1400A6F, ZX1400B6F
Valve Timing: Inlet: Open Close Duration Exhaust: Open Close Duration Lubrication System Engine Oil: Type Viscosity Capacity	41° (BTDC) 71° (ABDC) 292° 64° (BBDC) 34° (ATDC) 278° Forced lubrication (wet sump with cooler) API SE, SF or SG API SH, SJ or SL with JASO MA SAE10W-40 4.5 L (4.8 US qt)
Drive Train Primary Reduction System: Type Reduction Ratio Clutch Type Transmission: Type Gear Ratios: 1st 2nd 3rd 4th 5th 6th Final Drive System: Type Reduction Ratio Overall Drive Ratio	Gear 1.541 (94/61) Wet multi disc 6-speed, constant mesh, return shift 2.625 (42/16) 1.947 (37/19) 1.545 (34/22) 1.333 (32/24) 1.154 (30/26) 1.036 (29/28) Chain drive 2.412 (41/17) 3.849 @Top gear
Frame Type Caster (Rake Angle) Trail Front Tire: Type Size Rear Tire: Type Size	Press, backbone 23° 94 mm (3.7 in.) Tubeless 120/70 ZR17 M/C (58 W) Tubeless 190/50 ZR17 M/C (73 W)

1-14 GENERAL INFORMATION

General Specifications

Items	ZX1400A6F, ZX1400B6F
Rim Size: Front Rear Front Suspension: Type Wheel Travel Rear Suspension: Type Wheel Travel Brake Type: Front Rear	17 × 3.50 17 × 6.00 Telescopic fork (upside-down) 117 mm (4.6 in.) Swingarm (uni-trak) 122 mm (4.8 in.) Dual discs Single disc
Electrical Equipment Battery Headlight: Type Bulb: High Low Tail/Brake Light Alternator: Type Rated Output	12 V 14 Ah Semi-sealed beam 12 V 55 W + 65 W (quartz-halogen) × 2 12 V 55 W (quartz-halogen) × 2 12 V 0.5/4.9 W (LED) Three-phase AC 35 A/14 V @5 000 r/min (rpm)

Specifications subject to change without notice, and may not apply to every country.

Technical Information-CAN (Controller Area Network) Communication System

Overview

The CAN communication system is used for transmitting and receiving data that is sent to the meter unit and ECU. A LCD (liquid crystal display) display in the meter unit displays information such as battery voltage, fuel consumption, and service codes in addition to the conventional indicator functions.

1. Meter Display

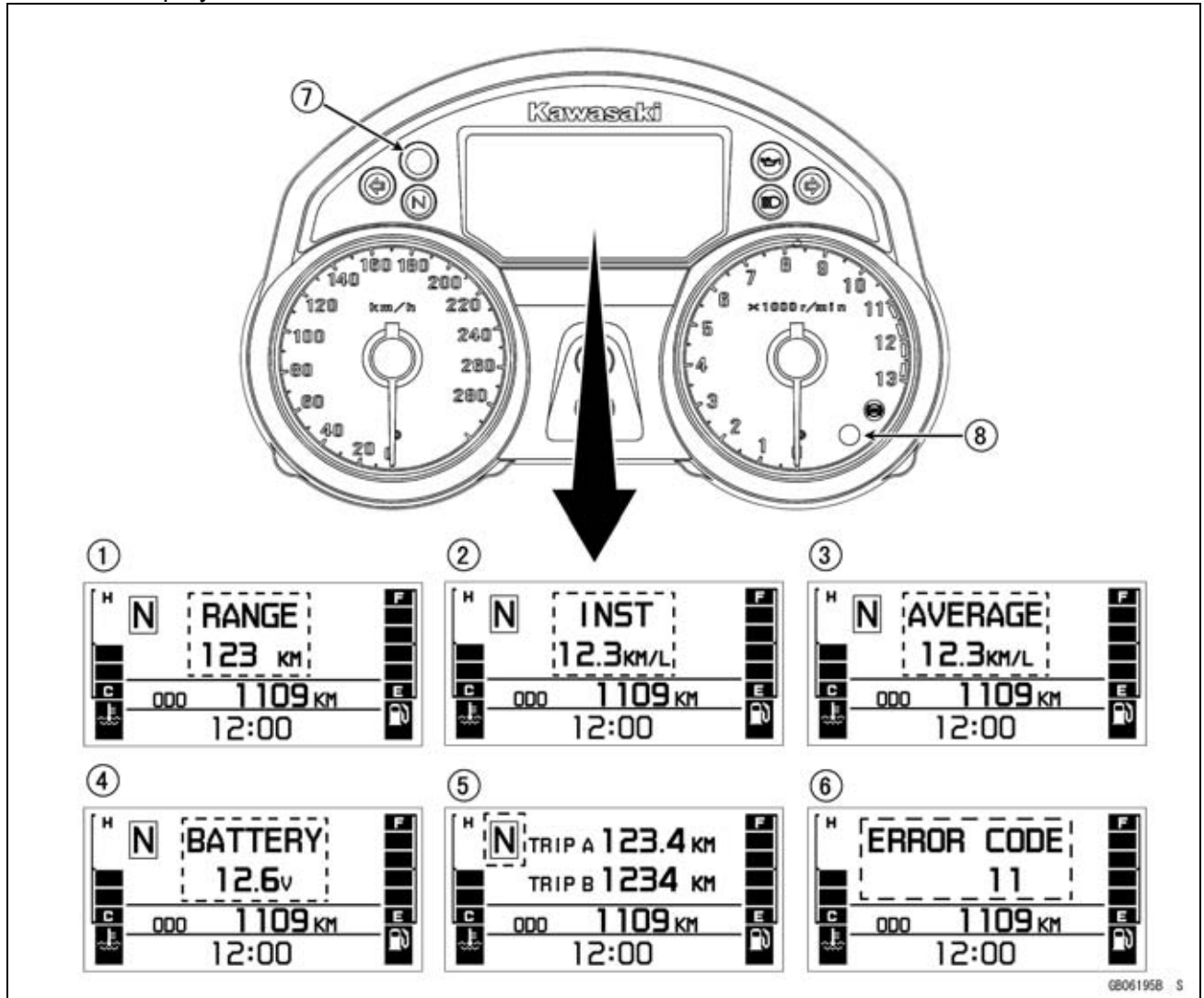

- | | |
|-------------------------------|-----------------------------|
| 1. Fuel Mileage Range | 5. Gear Position |
| 2. Fuel Consumption (Current) | 6. Service Code |
| 3. Fuel Consumption (Average) | 7. Immobilizer Registration |
| 4. Battery Voltage | 8. Clutch Engagement Timing |

2. CAN is a multi-cast serial bus standard (ISO protocol). Data is transmitted by changing the voltage signal of the two bus leads which are composed of high and low voltage wires twisted together. Since the high-speed ISO standard is used (transmission speeds of up to 500 kbps*), large quantities of data can be transmitted and received in a short period of time.

*bps: bit/sec → the number of signals (0 or 1) transmittable/receivable per second

1-16 GENERAL INFORMATION

Technical Information-CAN (Controller Area Network) Communication System

Structure and Function

1. In the CAN communication system, anti-noise twisted pair leads are used (two leads).

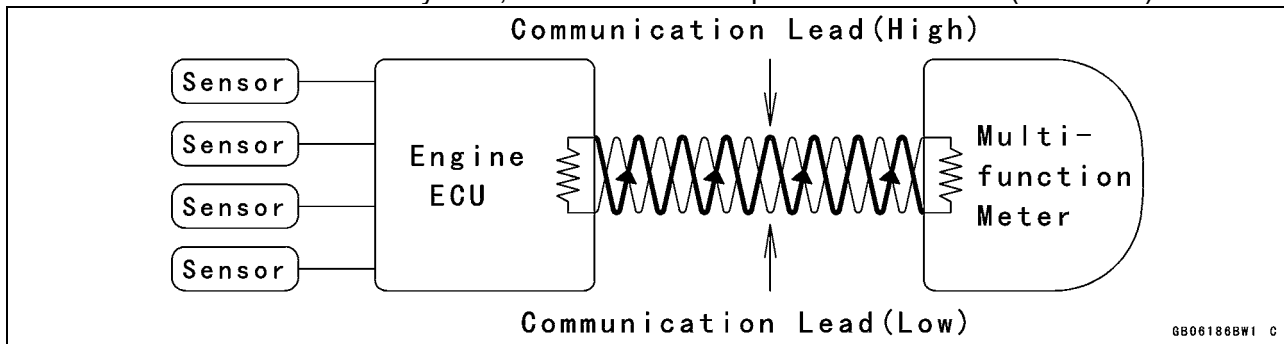

Twisted Pair Leads [A] (In the main harness)

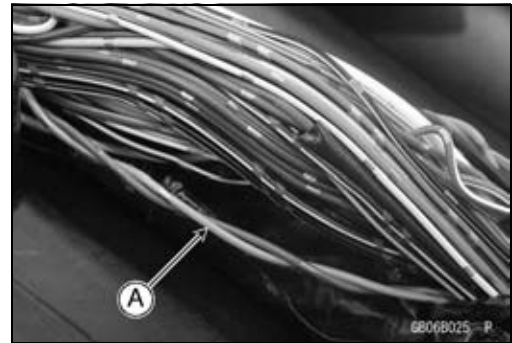

2. Data is transmitted from the two nodes-the ECU and meter unit-on the CAN bus and does not contain specific bus addresses of either node.

Instead, the content of a data stream, such as engine rpm, is labeled with an identifier that is unique throughout the network. All nodes on the network receive the data and each performs an acceptance test on the identifier to determine if the message (and its data) is relevant to that particular node.

If a message is relevant to a particular node (meter unit), it will be processed and displayed otherwise it is ignored. The unique data identifier also determines the priority of the message. In situations where the two nodes attempt to transmit at the same time, a non-destructive arbitration technique guarantees that the messages are sent in order of importance.

3. The CAN data that is transmitted from the ECU to the meter unit are engine rpm, water temperature, gear position, starter lockout switch, self-diagnosis information and *fuel injected volume. And the data transmitted from the meter to the ECU is vehicle speed.

*Fuel injected volume is converted into the fuel consumption by the meter unit.

Technical Information-CAN (Controller Area Network) Communication System

System failure and maintenance

1. Detection of a system failure

When the DFI or immobilizer system fails, the information will be shown on the LCD under the "ignition switch ON" condition.

2. System maintenance

1. Do not add a by-pass lead to the twisted pair lead. This can damage components.

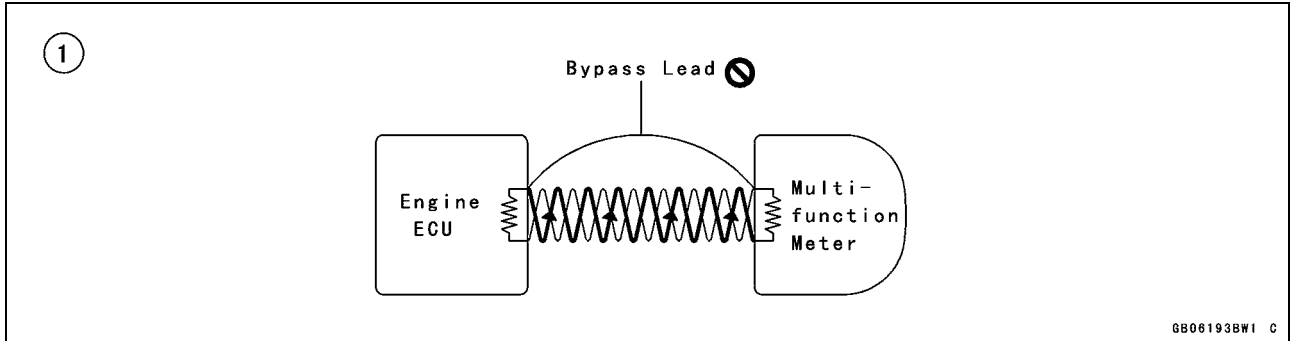

2. Do not modify the twisted pair lead or loosen/tighten the number of twists. Such modifications of the leads can cause the deterioration of the anti-noise characteristics resulting in communication errors.

1-18 GENERAL INFORMATION

Unit Conversion Table

Prefixes for Units

Prefix	Symbol	Power
mega	M	× 1 000 000
kilo	k	× 1 000
centi	c	× 0.01
milli	m	× 0.001
micro	μ	× 0.000001

Units of Mass

kg	×	2.205	=	lb
g	×	0.03527	=	oz

Units of Volume

L	×	0.2642	=	gal (US)
L	×	0.2200	=	gal (imp)
L	×	1.057	=	qt (US)
L	×	0.8799	=	qt (imp)
L	×	2.113	=	pint (US)
L	×	1.816	=	pint (imp)
mL	×	0.03381	=	oz (US)
mL	×	0.02816	=	oz (imp)
mL	×	0.06102	=	cu in

Units of Force

N	×	0.1020	=	kg
N	×	0.2248	=	lb
kg	×	9.807	=	N
kg	×	2.205	=	lb

Units of Length

km	×	0.6214	=	mile
m	×	3.281	=	ft
mm	×	0.03937	=	in

Units of Torque

N·m	×	0.1020	=	kgf·m
N·m	×	0.7376	=	ft·lb
N·m	×	8.851	=	in·lb
kgf·m	×	9.807	=	N·m
kgf·m	×	7.233	=	ft·lb
kgf·m	×	86.80	=	in·lb

Units of Pressure

kPa	×	0.01020	=	kgf/cm ²
kPa	×	0.1450	=	psi
kPa	×	0.7501	=	cmHg
kgf/cm ²	×	98.07	=	kPa
kgf/cm ²	×	14.22	=	psi
cmHg	×	1.333	=	kPa

Units of Speed

km/h	×	0.6214	=	mph
------	---	--------	---	-----

Units of Power

kW	×	1.360	=	PS
kW	×	1.341	=	HP
PS	×	0.7355	=	kW
PS	×	0.9863	=	HP

Units of Temperature

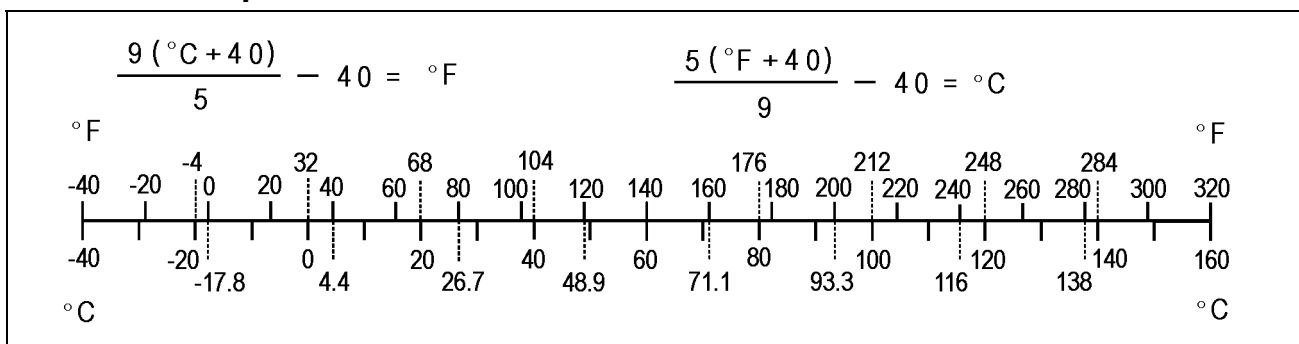

Periodic Maintenance

Table of Contents

Periodic Maintenance Chart	2-3
Torque and Locking Agent.....	2-6
Specifications	2-12
Special Tools	2-14
Maintenance Procedure	2-15
Fuel System (DFI).....	2-15
Throttle Control System Inspection.....	2-15
Engine Vacuum Synchronization Inspection.....	2-15
Idle Speed Inspection	2-19
Idle Speed Adjustment.....	2-19
Fuel Hose Inspection (fuel leak, damage, installation condition).....	2-19
Cooling System.....	2-20
Coolant Level Inspection.....	2-20
Radiator Hose and Pipe Inspection	2-20
Evaporative Emission Control System (California Model)	2-21
Evaporative Emission Control System Inspection	2-21
Air Suction System	2-21
Air Suction System Damage Inspection.....	2-21
Engine Top End	2-22
Valve Clearance Inspection	2-22
Clutch and Drive Train	2-27
Clutch Operation Inspection	2-27
Clutch Fluid Level Inspection	2-27
Clutch Fluid Leak Inspection.....	2-28
Clutch Hose and Pipe Damage and Installation Condition Inspection.....	2-28
Wheels/Tires.....	2-29
Air Pressure Inspection.....	2-29
Wheel/Tire Damage Inspection.....	2-29
Tire Tread Wear Inspection	2-29
Wheel Bearing Damage Inspection	2-30
Drive Train	2-30
Drive Chain Lubrication Condition Inspection.....	2-30
Drive Chain Slack Inspection.....	2-31
Drive Chain Slack Adjustment	2-31
Wheel Alignment Inspection	2-32
Drive Chain Wear Inspection	2-32
Chain Guide Wear Inspection	2-33
Brake System	2-34
Brake Fluid Leak (Brake Hose and Pipe) Inspection	2-34
Brake Hose and Pipe Damage and Installation Condition Inspection.....	2-35
Brake Operation Inspection	2-35
Brake Fluid Level Inspection.....	2-35
Brake Pad Wear Inspection	2-36
Brake Light Switch Operation Inspection	2-37
Suspensions	2-37
Front Forks/Rear Shock Absorber Operation Inspection.....	2-37
Front Fork Oil Leak Inspection.....	2-38
Rear Shock Absorber Oil Leak Inspection	2-38
Rocker Arm Operation Inspection.....	2-38
Tie-Rod Operation Inspection	2-38

2-2 PERIODIC MAINTENANCE

Steering System	2-39
Steering Play Inspection	2-39
Steering Play Adjustment.....	2-39
Steering Stem Bearing Lubrication	2-40
Electrical System	2-41
Lights and Switches Operation Inspection.....	2-41
Headlight Aiming Inspection	2-44
Sidestand Switch Operation Inspection	2-45
Engine Stop Switch Operation Inspection.....	2-46
Others	2-46
Chassis Parts Lubrication	2-46
Bolts, Nuts and Fasteners Tightness Inspection.....	2-47
Replacement Parts	2-48
Air Cleaner Element Replacement.....	2-48
Fuel Hose Replacement	2-49
Coolant Change	2-51
Radiator Hose and O-ring Replacement.....	2-53
Engine Oil Change.....	2-53
Oil Filter Replacement	2-54
Brake Hose and Pipe Replacement.....	2-55
Brake Fluid Change	2-57
Master Cylinder Rubber Parts Replacement	2-58
Caliper Rubber Parts Replacement	2-59
Rear Caliper Assembly	2-62
Clutch Hose and Pipe Replacement.....	2-63
Rubber Parts of Clutch Master Cylinder/Slave Cylinder Replacement.....	2-64
Clutch Fluid Change	2-66
Spark Plug Replacement	2-66

Periodic Maintenance Chart

The scheduled maintenance must be done in accordance with this chart to keep the motorcycle in good running condition. **The initial maintenance is vitally important and must not be neglected.**

FREQUENCY		* ODOMETER READING × 1000 km (× 1000 mile)							See Page	
		Whichever comes first ↓	1 (0.6)	6 (4)	12 (7.5)	18 (12)	24 (15)	30 (20)		36 (24)
INSPECTION		Every								
Fuel System										
Throttle control system (play, smooth return, no drag) - inspect		year	•		•		•		•	2-15
Engine vacuum synchronization-inspect					•		•		•	2-15
Idle speed-inspect			•		•		•		•	2-19
Fuel leak (fuel hose and pipe) - inspect		year	•		•		•		•	2-19
Fuel hose and pipe damage-inspect		year	•		•		•		•	2-19
Fuel hose and pipe installation condition-inspect		year	•		•		•		•	2-19
Cooling System										
Coolant level - inspect			•		•		•		•	2-20
Coolant leak (radiator hose and pipe) - inspect		year	•		•		•		•	2-20
Radiator hose damage - inspect		year	•		•		•		•	2-20
Radiator hose installation condition - inspect		year	•		•		•		•	2-20
Evaporative Emission Control System (CAL)										
Evaporative emission control system function - inspect			•	•	•	•	•	•	•	2-21
Air Suction System										
Air suction system damage - inspect					•		•		•	2-21
Engine Top End										
Valve clearance - inspect	US, CA, AU Model						•			2-22
	Other than US, CA, AU Model	Every 42 000 km (26 000 mile)								
Clutch and Drive Train										
Clutch operation (play, disengagement, engagement) - inspect			•		•		•		•	2-27
Clutch fluid level - inspect		6 months	•	•	•	•	•	•	•	2-27
Clutch fluid leak (clutch hose and pipe) - inspect		year	•	•	•	•	•	•	•	2-28
Clutch hose and pipe damage - inspect		year	•	•	•	•	•	•	•	2-28
Clutch hose installation condition - inspect		year	•	•	•	•	•	•	•	2-28
Wheels and Tires										
Tire air pressure - inspect		year			•		•		•	2-29
Wheels/tires damage - inspect					•		•		•	2-29
Tire tread wear abnormal wear - inspect					•		•		•	2-29
Wheel bearing damage - inspect		year			•		•		•	2-30

2-4 PERIODIC MAINTENANCE

Periodic Maintenance Chart

FREQUENCY	Whichever comes first →		* ODOMETER READING × 1000 km (× 1000 mile)						See Page	
	↓		1	6	12	18	24	30		36
INSPECTION	Every		(0.6)	(4)	(7.5)	(12)	(15)	(20)	(24)	
Final Drive										
Drive chain lubrication condition - inspect #	Every 600 km (400 mile) after driving in rain									2-30
Drive chain slack - inspect #	Every 1 000 km (600 mile)									2-31
Drive chain wear - inspect #				•		•		•		2-32
Drive chain guide wear - inspect				•		•		•		2-33
Brake System										
Brake fluid leak (brake hose and pipe) - inspect	year	•	•	•	•	•	•	•	•	2-34
Brake hose and pipe damage - inspect	year	•	•	•	•	•	•	•	•	2-35
Brake hose installation condition - inspect	year	•	•	•	•	•	•	•	•	2-35
Brake operation (effectiveness, play, no drag) - inspect	year	•	•	•	•	•	•	•	•	2-35
Brake fluid level - inspect	6 months	•	•	•	•	•	•	•	•	2-35
Brake pad wear - inspect #			•	•	•	•	•	•	•	2-36
Brake light switch operation - inspect		•	•	•	•	•	•	•	•	2-37
Suspensions										
Front forks/rear shock absorber operation (damping and smooth stroke) - inspect				•		•		•		2-37
Front forks/rear shock absorber oil leak - inspect	year			•		•		•		2-38
Rocker arm operation - inspect				•		•		•		2-38
Tie-rods operation - inspect				•		•		•		2-38
Steering System										
Steering play - inspect	year	•		•		•		•		2-39
Steering stem bearings-lubricate	2 years					•				2-39
Electrical System										
Lights and switches operation - inspect	year			•		•		•		2-41
Headlight aiming - inspect	year			•		•		•		2-44
Sidestand switch operation - inspect	year			•		•		•		2-45
Engine stop switch operation - inspect	year			•		•		•		2-46
Others										
Chassis parts-lubricate	year			•		•		•		2-46
Bolts, nuts and fasteners tightness - inspect		•		•		•		•		2-47

#: Service more frequently when operating in severe conditions; dusty, wet, muddy, high speed or frequent starting/stopping.

*: For higher odometer readings, repeat at the frequency interval established here.

Periodic Maintenance Chart

Periodic Replacement Parts

CHANGE/REPLACEMENT	FREQUENCY	* ODOMETER READING × 1000 km (× 1000 mile)						See Page
	Whichever come first ↓ Every	1 (0.6)	12 (7.5)	18 (12)	24 (15)	36 (24)	48 (30)	
Air cleaner element #	Every 18 000 km (12 000 mile)						2-48	
Fuel hose	4 years						●	2-49
Coolant	3 years					●		2-51
Radiator hoses and O-rings	3 years					●		2-53
Engine oil #	year	●	●		●	●	●	2-53
Oil filter	year	●	●		●	●	●	2-54
Brake hose and pipe	4 years						●	2-55
Brake fluid	2 years				●		●	2-57
Rubber parts of brake master cylinder/caliper	4 years						●	2-58
Clutch hose and pipe	4 years						●	2-63
Rubber parts of clutch master cylinder/slave cylinder	4 years						●	2-64
Clutch fluid	2 years				●		●	2-66
Spark plugs			●		●	●	●	2-66

#: Service more frequently when operating in severe conditions; dusty, wet, muddy, high speed or frequent starting/stopping.

*: For higher odometer readings, repeat at the frequency interval established here.

2-6 PERIODIC MAINTENANCE

Torque and Locking Agent

The following tables list the tightening torque for the major fasteners requiring use of a non-permanent locking agent or silicone sealant etc.

Letters used in the "Remarks" column mean:

AL: Tighten the two clamp bolts alternately two times to ensure even tightening torque.

G: Apply grease to the threads.

L: Apply a non-permanent locking agent to the threads.

M: Apply molybdenum disulfided grease.

MO: Apply molybdenum disulfide grease oil

(mixture of engine oil and molybdenum disulfide grease in a weight ration is 10 : 1).

R: Replacement Parts

S: Tighten the fasteners following the specified sequence.

Si: Apply silicone grease (ex. PBC grease).

SS: Apply silicone sealant.

Fastener	Torque			Remarks
	N·m	kgf·m	ft·lb	
Fuel System				
Air Cleaner Element Cover Bolts	6.9	0.70	61 in·lb	
Air Cleaner Element Holder Screws	6.9	0.70	61 in·lb	
Bypass Screws	0.2	0.02	1.8 in·lb	
Camshaft Position Sensor Bolt	9.8	1.0	87 in·lb	
Crankshaft Sensor Bolts	5.9	0.60	52 in·lb	L
Delivery Pipe Mounting Screws	5.0	0.51	44 in·lb	
Duct Clamp Bolts	2.0	0.20	18 in·lb	
Front Air Inlet Duct Mounting Bolts	9.8	1.0	87 in·lb	
Fuel Pump Bolts	9.8	1.0	87 in·lb	L, S
Gear Position Switch Lead Clamp Bolts	9.8	1.0	87 in·lb	
Gear Position Switch Screws	2.9	0.30	26 in·lb	L
Inlet Air Pressure Sensor Bracket Screws	3.5	0.36	31 in·lb	
Middle Air Inlet Duct Clamp Bolts	2.9	0.30	26 in·lb	
Middle Air Inlet Duct Mounting Bolts	9.8	1.0	87 in·lb	
Rear Air Inlet Duct Mounting Bolts	9.8	1.0	87 in·lb	
Speed Sensor Bolt	3.9	0.40	35 in·lb	L
Throttle Body Assy Holder Bolts	9.8	1.0	87 in·lb	S
Throttle Body Assy Holder Clamp Bolts	2.0	0.20	18 in·lb	
Vehicle-down Sensor Bolts	5.9	0.60	52 in·lb	
Water Temperature Sensor	25	2.5	18	
Cooling System				
Coolant Drain Plug	12	1.2	106 in·lb	
Coolant Fitting Bolts	8.8	0.90	78 in·lb	L
Oil Cooler Mounting Bolts	12	1.2	106 in·lb	S
Radiator Hose Clamp Screws	2.0	0.20	18 in·lb	
Thermostat Housing Cover Bolts	5.9	0.60	52 in·lb	
Thermostat Housing Mounting Bolts	9.8	1.0	87 in·lb	
Water Pump Cover Bolts	9.8	1.0	87 in·lb	
Water Temperature Sensor	25	2.5	18	

PERIODIC MAINTENANCE 2-7

Torque and Locking Agent

Fastener	Torque			Remarks
	N·m	kgf·m	ft·lb	
Engine Top End				
Air Suction Valve Cover Bolts	9.8	1.0	87 in·lb	L
Camshaft Cap Bolts	12	1.2	106 in·lb	S
Camshaft Chain Guide Bolts	12	1.2	106 in·lb	S
Camshaft Chain Tensioner Mounting Bolts	9.8	1.0	87 in·lb	
Camshaft Position Sensor Bolt	9.8	1.0	87 in·lb	
Cam Sprocket Mounting Bolts	15	1.5	11	L
Crankshaft Sensor Cover Bolts	9.8	1.0	87 in·lb	L (1)
Cylinder Head Bolts (M6)	12	1.2	106 in·lb	S
Cylinder Head Cover Bolts	9.8	1.0	87 in·lb	S
Cylinder Head Bolts (M11, First)	39	4.0	29	MO, S
Cylinder Head Bolts (M11, Final)	71	7.2	52	MO, S
Engine Bracket Bolts (M8)	25	2.5	18	R, S
Front Camshaft Chain Guide Bolt (Upper)	25	2.5	18	
Front Camshaft Chain Guide Bolt (Lower)	12	1.2	106 in·lb	
Front Engine Mounting Bolts (M10)	59	6.0	44	R, S
Muffler Body Mounting Bolts	34	3.5	25	
Spark Plugs	13	1.3	115 in·lb	
Throttle Body Holder Bolts	9.8	1.0	87 in·lb	S
Throttle Body Assy Holder Clamp Bolts	2.0	0.20	18 in·lb	
Water Passage Plugs	20	2.0	15	L
Clutch				
Clutch Cover Bolts	9.8	1.0	87 in·lb	L (1)
Clutch Hose Banjo Bolt	25	2.5	18	
Clutch Hub Nut	135	14	100	R
Clutch Lever Pivot Bolt	1.0	0.10	8.9 in·lb	
Clutch Lever Pivot Bolt Locknut	5.9	0.60	52 in·lb	
Clutch Master Cylinder Bleed Valve	7.8	0.80	69 in·lb	
Clutch Master Cylinder Clamp Bolts	8.8	0.90	78 in·lb	S
Clutch Slave Cylinder Bleed Valve	7.8	0.80	69 in·lb	
Clutch Slave Cylinder Bolts	–	–	–	L
Clutch Spring Bolts	8.8	0.90	78 in·lb	
Oil Filler Cap	–	–	–	Hand-tighten
Engine Lubrication System				
Engine Oil Drain Bolt	30	3.0	22	
Holder Mounting Bolt	35	3.6	26	L
Oil Cooler Mounting Bolts	12	1.2	106 in·lb	S
Oil Filter	31	3.2	23	G, R
Oil Pan Bolts	9.8	1.0	87 in·lb	
Oil Pan Plate Bolts	9.8	1.0	87 in·lb	L
Oil Passage Plug	20	2.0	15	L
Oil Pressure Relief Valve	15	1.5	11	L

2-8 PERIODIC MAINTENANCE

Torque and Locking Agent

Fastener	Torque			Remarks
	N·m	kgf·m	ft·lb	
Oil Pressure Switch	15	1.5	11	SS
Oil Pressure Switch Terminal Bolt	1.5	0.15	13 in·lb	G
Oil Pump Cover Bolts	9.8	1.0	87 in·lb	
Engine Removal/Installation				
Adjusting Collars	25	2.5	18	M
Engine Bracket Bolts (M8)	25	2.5	18	S, R
Engine Mounting Nuts (M12)	59	6.0	44	S
Front Engine Mounting Bolts (M10)	59	6.0	44	S, R
Subframe Bolts	23	2.3	17	R
Crankshaft/Transmission				
Balancer Shaft Clamp Bolts	9.8	1.0	87 in·lb	
Balancer Shaft Clamp Lever Bolts	25	2.5	18	
Bearing Position Plate Screws	4.9	0.50	43 in·lb	L
Breather Cover Bolts	9.8	1.0	87 in·lb	
Breather Plate Screws	9.8	1.0	87 in·lb	L
Connecting Rod Big End Nuts	see the text	←	←	←
Crankcase Bolts (M6, L = 25 mm)	12	1.2	106 in·lb	S
Crankcase Bolts (M6, L = 40 mm)	12	1.2	106 in·lb	S
Crankcase Bolt (M6, L = 50 mm)	12	1.2	106 in·lb	S
Crankcase Bolt (M6, L = 65 mm)	12	1.2	106 in·lb	S
Crankcase Bolts (M7, L = 45 mm)	20	2.0	15	S
Crankcase Bolt (M7, L = 50 mm)	20	2.0	15	S
Crankcase Bolts (M7, L = 60 mm)	20	2.0	15	S
Crankcase Bolts (M7, L = 65 mm)	20	2.0	15	S
Crankcase Bolt (M7, L = 85 mm)	20	2.0	15	S
Crankcase Bolt (M7, L = 110 mm)	20	2.0	15	S
Crankcase Bolts (M8, L = 70 mm)	27	2.8	20	S
Crankcase Bolts (M8, L = 80 mm)	27	2.8	20	S
Crankcase Bolts (M10, L = 90 mm)	47	4.8	35	MO, S
Crankcase Bolts (M10, L = 120 mm)	47	4.8	35	MO, S
Drive Shaft Cover Bolts	25	2.5	18	L
Gear Positioning Lever Bolt	12	1.2	106 in·lb	
Gear Position Switch Lead Clamp Bolt	9.8	1.0	87 in·lb	
Gear Position Switch Screws	2.9	0.30	26 in·lb	L
Oil Passage Plugs	20	2.0	15	L
Shift Drum Bearing Holder Screws	4.9	0.50	43 in·lb	L
Starter Clutch Shaft Bolt	9.8	1.0	87 in·lb	L
Starter Clutch Shaft Plate Bolt	9.8	1.0	87 in·lb	L
Shift Drum Cam Holder Bolt	12	1.2	106 in·lb	L
Shift Shaft Return Spring Pin	29	3.0	21	L
Timing Rotor Bolt	39	4.0	29	
Torque Limiter Bolt	25	2.5	18	L

Torque and Locking Agent

Fastener	Torque			Remarks
	N·m	kgf·m	ft·lb	
Wheels/Tires				
Front Axle Clamp Bolts	20	2.0	15	AL
Front Axle Nut	127	13.0	94	
Rear Axle Nut	127	13.0	94	
Final Drive				
Chain Guide Bolt	12	1.2	106 in·lb	L
Chain Guide Bolts	9.8	1.0	87 in·lb	L
Engine Sprocket Cover Bolts	9.8	1.0	87 in·lb	
Engine Sprocket Nut	125	13.0	92	MO
Rear Axle Nut	127	13.0	94	
Rear Sprocket Nuts	69	7.0	51	
Speed Sensor Bolt	3.9	0.40	35 in·lb	L
Stud Bolts	14.7	1.5	11	L
Brakes				
Bleed Valves	7.8	0.80	69 in·lb	
Brake Hose Banjo Bolts	25	2.5	18	
Brake Lever Pivot Bolt	1.0	0.10	9 in·lb	Si
Brake Lever Pivot Bolt Locknut	5.9	0.60	52 in·lb	
Brake Pedal Bolt	8.8	0.90	78 in·lb	
Brake Pipe Joint Nuts (ZX1400B Models)	18	1.8	13	
Front Brake Disc Mounting Bolts	27	2.8	20	L
Front Brake Light Switch Screw	1.2	0.12	11 in·lb	
Front Brake Pad Pins	17.2	1.8	13	
Front Brake Reservoir Cap Stopper Screw	1.2	0.12	11 in·lb	
Front Caliper Assembly Bolts	27	2.8	20	L
Front Caliper Mounting Bolts	34	3.5	25	
Front Master Cylinder Bleed Valve	7.8	0.80	69 in·lb	
Front Master Cylinder Clamp Bolts	8.8	0.90	78 in·lb	S
Rear Brake Disc Mounting Bolts	27	2.5	18	L
Rear Brake Pad Pin	17.2	1.8	13	
Rear Caliper Assembly Bolts	37	3.8	27	L
Rear Caliper Mounting Bolts	25	2.5	18	
Rear Master Cylinder Mounting Bolts	25	2.5	18	
Rear Master Cylinder Push Rod Locknut	17.2	1.8	13	
Suspension				
Front Axle Clamp Bolts	20	2.0	15	AL
Front Fork Bottom Allen Bolts	23	2.3	17	L
Front Fork Clamp Bolts (Upper)	20	2.0	15	
Front Fork Clamp Bolts (Lower)	30	3.1	22	AL
Front Fork Top Plugs	22	2.2	16	
Piston Rod Nuts	28	2.9	21	
Rear Shock Absorber Nut (Upper)	34	3.5	25	
Rear Shock Absorber Nut (Lower)	34	3.5	25	

2-10 PERIODIC MAINTENANCE

Torque and Locking Agent

Fastener	Torque			Remarks
	N·m	kgf·m	ft·lb	
Swingarm Pivot Adjusting Collar	20	2.0	15	
Swingarm Pivot Adjusting Collar Locknut	98	10.0	72	
Swingarm Pivot Shaft Nut	108	11.0	80	
Tie-Rod Nuts	59	6.0	44	
Uni-Trak Rocker Arm Nut	34	3.5	25	
Steering				
Front Fork Clamp Bolts (Upper)	20	2.0	15	
Front Fork Clamp Bolts (Lower)	30	3.1	22	AL
Handlebar Bolts	34	3.5	25	L
Handlebar Holder Bolts	25	2.5	18	AL
Steering Stem Head Nut	78	8.0	58	
Steering Stem Nut	23	2.3	17	
Switch Housing Screws	3.5	0.36	31 in·lb	
Frame				
Center Stand Bolts	44	4.5	32	
Front Footpeg Bracket Bolts	25	2.5	18	
Grab Rail Mounting Bolts	25	2.5	18	
Rear Fender Mounting Screws	1.2	0.12	11 in·lb	
Rear Footpeg Bracket Bolts	25	2.5	18	
Rear Frame Bolts	44	4.5	32	L
Rear Frame Pipe Bolts	44	4.5	32	
Rear Frame Pipe Nuts	44	4.5	32	
Seat Lock Bracket Screws	1.2	0.12	11 in·lb	
Sidestand Bolt	44	4.5	32	
Sidestand Bracket Bolts	49	5.0	36	L
Sidestand Switch Bolt	8.8	0.90	78 in·lb	L
Windshield Mounting Bolts	0.42	0.043	3.7 in·lb	
Electrical System				
Alternator Cover Bolts	9.8	1.0	87 in·lb	
Alternator Lead Holding Plate Bolts	8.3	0.85	73 in·lb	L
Alternator Rotor Bolt (First)	69	7.0	51	S
Alternator Rotor Bolt (Final)	110	11.2	81	S
Camshaft Position Sensor Bolt	9.8	1.0	87 in·lb	
Crankshaft Sensor Bolts	5.9	0.60	52 in·lb	L
Crankshaft Sensor Cover Bolts	9.8	1.0	87 in·lb	L (1)
Engine Ground Terminal Bolt	9.8	1.0	87 in·lb	
Front Brake Light Switch Screw	1.2	0.12	11 in·lb	
Front Turn Signal Light Mounting Screws	1.2	0.12	11 in·lb	
Fuel Level Sensor Bolts	6.9	0.70	61 in·lb	L
Gear Position Switch Lead Clamp Bolts	9.8	1.0	87 in·lb	
Gear Position Switch Screws	2.9	0.30	26 in·lb	L
Headlight Mounting Screws	1.2	0.12	11 in·lb	
Left Switch Housing Screws	3.5	0.36	31 in·lb	

Torque and Locking Agent

Fastener	Torque			Remarks
	N·m	kgf·m	ft·lb	
Licence Plate Light Cover Mounting Screws	0.9	0.09	8 in·lb	
Licence Plate Light Mounting Screws	1.2	0.12	11 in·lb	
Rear Turn Signal Light Mounting Screws	1.2	0.12	11 in·lb	
Regulator Rectifier Bolts	9.8	1.0	87 in·lb	
Right Switch Housing Screws	3.5	0.36	31 in·lb	
Sidestand Switch Bolt	8.8	0.90	78 in·lb	L
Spark Plugs	13	1.3	115 in·lb	
Speed Sensor Bolt	3.9	0.40	34 in·lb	L
Starter Lockout Switch Screw	0.7	0.07	6 in·lb	
Starter Motor Cable Mounting Bolt	3.9	0.40	34 in·lb	
Starter Motor Cable Terminal Nut	5.9	0.60	52 in·lb	
Starter Motor Mounting Bolts	9.8	1.0	87 in·lb	
Starter Motor Terminal Locknut	6.9	0.70	61 in·lb	
Starter Motor Through Bolts	3.4	0.35	30 in·lb	
Stator Coil Bolts	12	1.2	106 in·lb	
Tail/Brake Light Mounting Screws	1.2	0.12	11 in·lb	
Water Temperature Sensor	25	2.5	18	

The table below, relating tightening torque to thread diameter, lists the basic torque for the bolts and nuts. Use this table for only the bolts and nuts which do not require a specific torque value. All of the values are for use with dry solvent-cleaned threads.

Basic Torque for General Fasteners

Threads diameter (mm)	Torque		
	N·m	kgf·m	ft·lb
5	3.4 ~ 4.9	0.35 ~ 0.50	30 ~ 43 in·lb
6	5.9 ~ 7.8	0.60 ~ 0.80	52 ~ 69 in·lb
8	14 ~ 19	1.4 ~ 1.9	10.0 ~ 13.5
10	25 ~ 34	2.6 ~ 3.5	19.0 ~ 25
12	44 ~ 61	4.5 ~ 6.2	33 ~ 45
14	73 ~ 98	7.4 ~ 10.0	54 ~ 72
16	115 ~ 155	11.5 ~ 16.0	83 ~ 115
18	165 ~ 225	17.0 ~ 23.0	125 ~ 165
20	225 ~ 325	23 ~ 33	165 ~ 240

2-12 PERIODIC MAINTENANCE

Specifications

Item	Standard	Service Limit
Fuel System		
Throttle Grip Free Play	2 ~ 3 mm (0.08 ~ 0.12 in.)	---
Idle Speed	1 100 ±50 r/min (rpm)	---
Throttle Body Vacuum	39 ±1.33 kPa (293 ±10 mmHg) at idle speed	---
Air Cleaner Element	Viscous paper element	---
Cooling System		
Coolant:		
Type (Recommended)	Permanent type antifreeze	---
Color	Green	---
Mixed Ratio	Soft water 50%, coolant 50%	---
Freezing Point	-35°C (-31°F)	---
Total Amount	3.4 L (3.6 US qt)	---
Engine Top End		
Valve Clearance:		
Exhaust	0.22 ~ 0.27 mm (0.0087 ~ 0.0106 in.)	---
Inlet	0.15 ~ 0.20 mm (0.0059 ~ 0.0079 in.)	---
Clutch		
Clutch Fluid:		
Grade	DOT4	---
Clutch Lever Free Play	Non-adjustable	---
Engine Lubrication System		
Engine Oil:		
Type	API SE, SF or SG API SH, SJ or SL with JASO MA	---
Viscosity	SAE 10W-40	---
Capacity	3.7 L (3.9 US qt) (when filter is not removed) 4.1 L (4.3 US qt) (when filter is removed) 4.5 L (4.8 US qt) (when engine is completely dry)	---
Level	Between upper and lower level lines (Wait 2 ~ 3 minutes after idling or running)	---
Wheels/Tires		
Tread Depth:		
Front	3.8 mm (0.15 in.)	1 mm (0.04 in.), (AT, CH, DE) 1.6 mm (0.06 in.)
Rear	4.8 mm (0.19 in.)	Up to 130 km/h (80 mph): 2 mm (0.08 in.), Over 130 km/h (80 mph): 3 mm (0.12 in.)
Air Pressure (when Cold):		
Front	Up to 180 kg (397 lb) load: 290 kPa (2.9 kgf/cm ² , 42 psi)	---
Rear	Up to 180 kg (397 lb) load: 290 kPa (2.9 kgf/cm ² , 42 psi)	---

Specifications

Item	Standard	Service Limit
Final Drive		
Drive Chain Slack	32 ~ 38 mm (1.3 ~ 1.5 in.)	---
Drive Chain Wear (20-link Length)	317.5 ~ 318.2 mm (12.50 ~ 12.53 in.)	323 mm (12.7 in.)
Standard Chain:		
Make	DAIDO	---
Type	DID50ZVM4 GC&B	---
Link	116 links	---
Brakes		
Brake Fluid:		
Grade	DOT4	---
Brake Pad Lining Thickness:		
Front	4.0 mm (0.16 in.)	1 mm (0.04 in.)
Rear	5.0 mm (0.20 in.)	1 mm (0.04 in.)
Brake Light Timing:		
Front	Pulled ON	---
Rear	On after about 10 mm (0.39 in.) of pedal travel	---
Electrical System		
Spark Plug:		
Type	NGK CR9EIA-9	---

2-14 PERIODIC MAINTENANCE

Special Tools

Inside Circlip Pliers:
57001-143

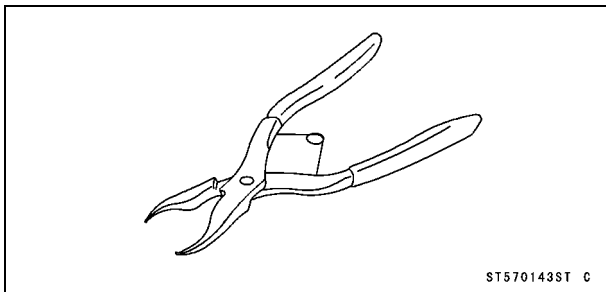

Pilot Screw Adjuster, C:
57001-1292

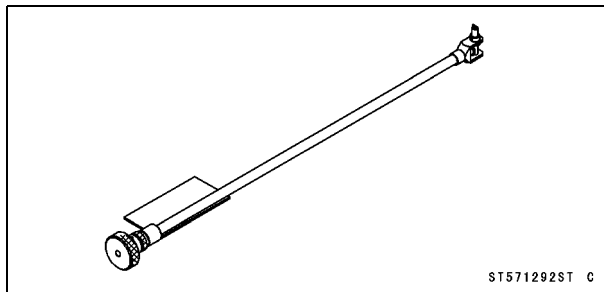

Steering Stem Nut Wrench:
57001-1100

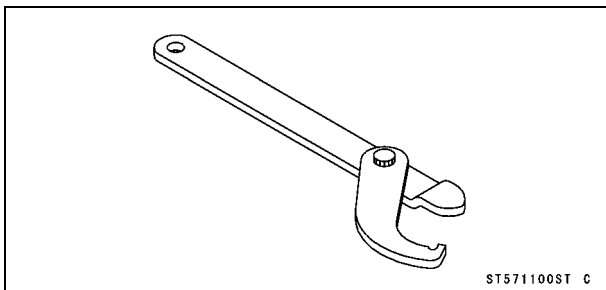

Vacuum Gauge:
57001-1369

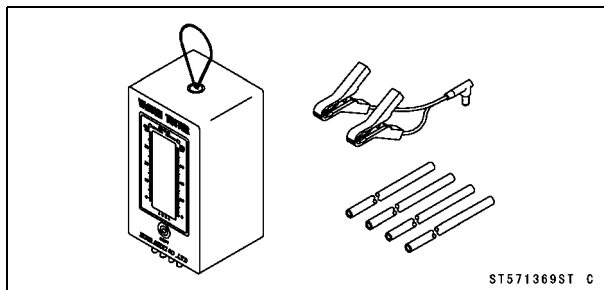

Jack:
57001-1238

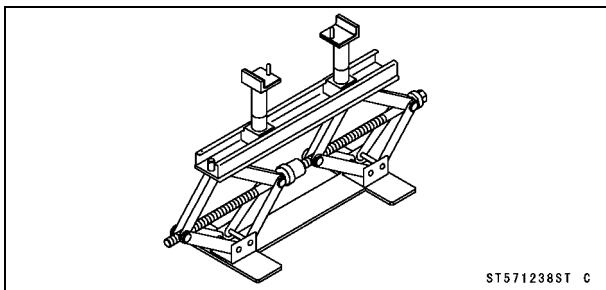

Pilot Screw Adjuster Adapter, $\phi 5$:
57001-1372

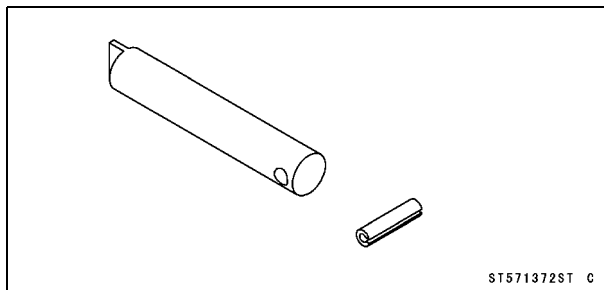

Oil Filter Wrench:
57001-1249

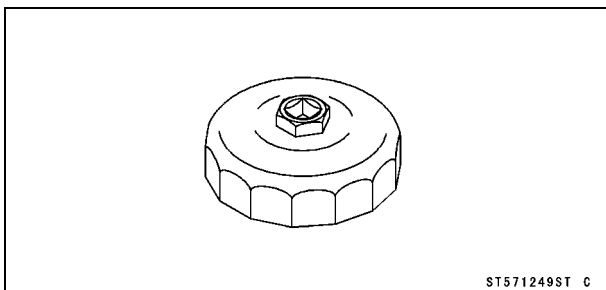

Jack Attachment:
57001-1608

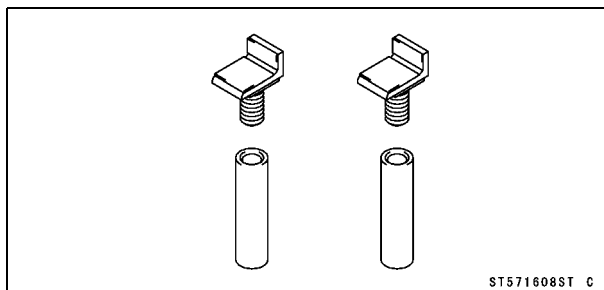

Maintenance Procedure

Fuel System (DFI)

Throttle Control System Inspection

- Check the throttle grip free play [A].
- ★ If the free play is incorrect, adjust the throttle cables.

Throttle Grip Free Play

Standard: 2 ~ 3 mm (0.08 ~ 0.12 in.)

- Check that the throttle grip [B] moves smoothly from full open to close, and the throttle closes quickly and completely by the return spring in all steering positions.
- ★ If the throttle grip does not return properly, check the throttle cables routing, grip free play, and cable damage. Then lubricate the throttle cable.
- Run the engine at the idle speed, and turn the handlebar all the way to the right and left to ensure that the idle speed does not change.
- ★ If the idle speed increases, check the throttle cable free play and the cable routing.

★ If necessary, adjust the throttle cable as follows.

- Loosen the locknuts [A] [B].
- Screw both throttle cable adjusters [C] [D] to give the throttle grip plenty of play.
- Turn the decelerator cable adjuster [C] until 2 ~ 3 mm (0.08 ~ 0.12 in.) of throttle grip play is obtained.
- Tighten the locknut [A].
- Turn the accelerator cable adjuster [D] until 2 ~ 3 mm (0.08 ~ 0.12 in.) of throttle grip play is obtained.
- Tighten the locknut [B].
- ★ If the free play cannot be adjusted with the adjusters, replace the cable.

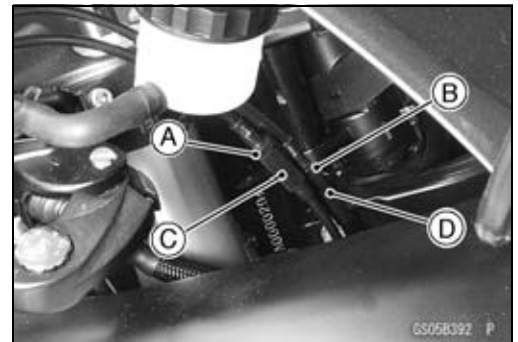
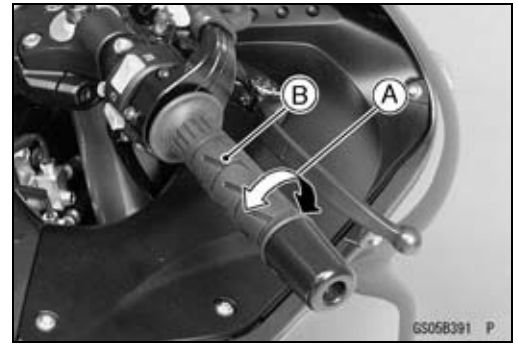

Engine Vacuum Synchronization Inspection

NOTE

○ These procedures are explained on the assumption that the inlet and exhaust systems of the engine are in good condition.

- Situate the motorcycle so that it is vertical.
- Remove:
 - Fuel Tank Cover (see Fuel Tank Removal in the Fuel System (DFI) chapter)
 - Left and Right Middle Fairings (see Middle Fairing Removal in the Frame chapter)
- Pull off the rubber caps [A] from the fittings of each throttle body.
 - Front [B]

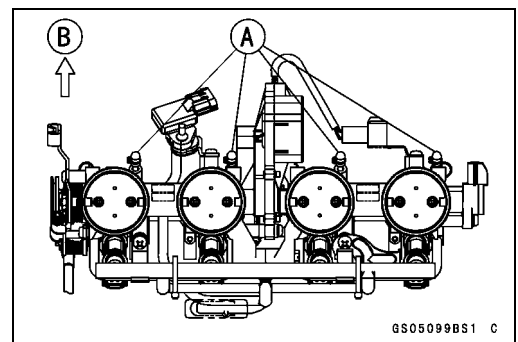
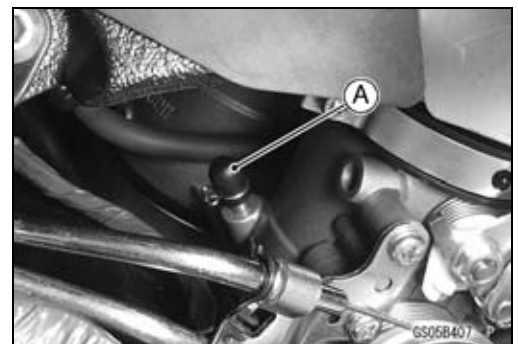

2-16 PERIODIC MAINTENANCE

Maintenance Procedure

- For the California Model, pull off the vacuum hoses [A].



- Pull off the air switching valve hose [A] from the air cleaner housing.
- Plug the air switching valve hose end and air cleaner housing hole.



- Connect a vacuum gauge (special tool) and hoses [A] to the fittings on the throttle body.

Special Tool - Vacuum Gauge: 57001-1369

- Connect a highly accurate tachometer [B] to one of the stick coil primary leads.



- Start the engine and warm it up thoroughly.
- Check the idle speed, using a highly accurate tachometer [A].
- ★ If the idle speed is out of the specified range, adjust it with the adjust screw.

CAUTION

Do not measure the idle speed by the tachometer of the meter unit.

- While idling the engine, inspect the throttle body vacuum, using the vacuum gauge [B].

Throttle Body Vacuum

**Standard: 39 ±1.33 kPa (293 ±10 mmHg) at Idle Speed
1 100 ±50 r/min (rpm)**



Maintenance Procedure

★ If any vacuum is not within specifications, first synchronize the balance of the left (#1, #2 throttle valves) and right (#3, #4 throttle valves) assemblies.

Example:

- #1: 260 mmHg
- #2: 290 mmHg
- #3: 250 mmHg
- #4: 270 mmHg

● With the engine at the correct idle speed, equalize higher vacuum of #1 or #2 (for example 290 mmHg) to higher vacuum of #3 or #4 (for example 270 mmHg) by turning the center adjusting screw [A].

Right Side View [B]

○ In this photo [C], the throttle body has been removed for clarity.

Special Tool - Pilot Screw Adjuster, C: 57001-1292
Pilot Screw Adjuster Adapter, φ5: 57001-1372

NOTE

○ After adjustment, the final vacuum measurement between the highest throttle valves may not be 290 mmHg (for example). The goal is to have the highest two vacuums between the left (#1 and #2) and right (#3 and #4) banks be the same and be within the service limits.

- Open and close the throttle after each measurement, and adjust the idle speed as necessary.
- Once the throttle valves have been synchronized, inspect output voltage of the main throttle sensor to ensure proper operation (procedure is explained at the end of this section).

★ If a value of measured vacuum pressure is out of the specified range after synchronization, adjust the bypass screws [A].

Special Tool - Pilot Screw Adjuster, C: 57001-1292
Pilot Screw Adjuster Adapter, φ5: 57001-1372

Rear View [B]

- Adjust lower vacuum between #1 and #2 to higher vacuum of #1 and #2.
- Adjust the lower vacuum between #3 and #4 to higher vacuum of #3 and #4.
- Open and close the throttle valves after each measurement, and adjust the idle speed as necessary.
- Check the vacuums as before.
- ★ If all vacuums are within the specification range, finish the engine vacuum synchronization.
- ★ If any vacuum cannot be adjusted within the specification, remove the bypass screws #1 ~ #4 and clean them.

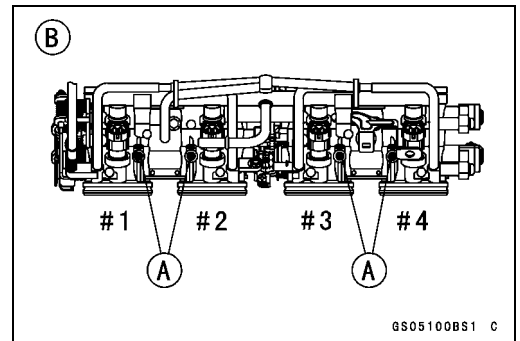
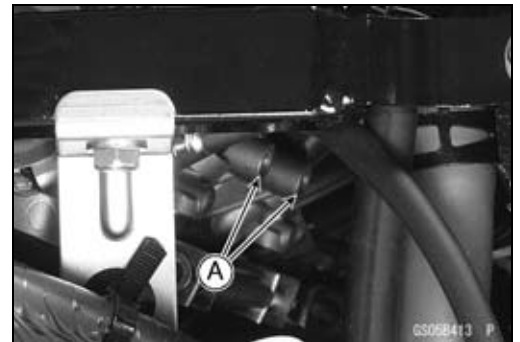
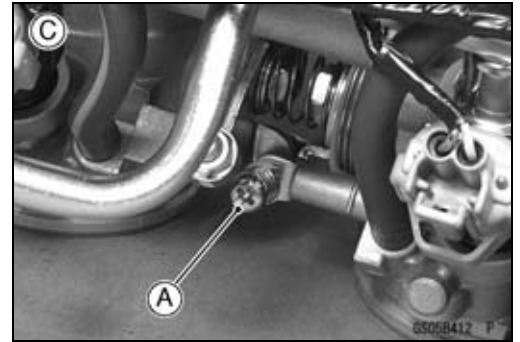
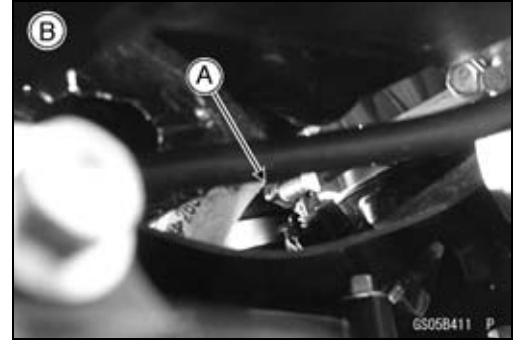

2-18 PERIODIC MAINTENANCE

Maintenance Procedure

- Turn in the bypass screw [A] with counting the number of turns until it seals fully but not tightly. Record the number of turns.

Torque - Bypass Screw: 0.2 N·m (0.02 kgf·m, 1.8 in·lb)

CAUTION

Do not over tighten them. They could be damaged, requiring replacement.

- Remove:
 - Bypass Screw
 - Spring [B]
 - Washer [C]
 - O-ring [D]
- Check the bypass screw and its hole for carbon deposits.
- ★ If any carbons accumulate, wipe the carbons off from the bypass screw and the hole, using a cotton pad penetrated with a high-flash point solvent.
- Replace the O-ring with a new one.
- Check the tapered portion [E] of the bypass screw for wear or damage.
- ★ If the bypass screw is worn or damaged, replace it.
- Turn in the bypass screw until it seats fully but not tightly.

Torque - Bypass Screw: 0.2 N·m (0.02 kgf·m, 1.8 in·lb)

- Back out the same number of turns counted when first turned in. This is to set the screw to its original position.

NOTE

○ A throttle body has different "turns out" of the bypass screw for each individual unit. On setting the bypass screw, use the "turns out" determined during disassembly.

- Repeat the same procedure for other bypass screws.
- Repeat the synchronization.
- ★ If the vacuums are correct, check the output voltage of the main throttle sensor (see Output Voltage Inspection of Main Throttle Sensor in the Fuel System (DFI) chapter).

Main Throttle Sensor Output Voltage

Connections to ECU

Meter (+) → Y/W lead (terminal 26)

Meter (-) → BR/BK lead (terminal 34)

Standard: DC 0.63 ~ 0.65 V (at idle throttle opening)

- ★ If the output voltage is out of the range, check the throttle input voltage of the main throttle sensor (see Input Voltage Inspection in the Main Throttle Sensor section in the Fuel System (DFI) chapter).
- Remove the vacuum gauge hoses and install the rubber caps on the original position.
- For the California Model, install the vacuum hoses.
- Route the vacuum hoses according to Cable, Wire, and Hose Routing section in the Appendix chapter. Refer to the diagram of the evaporative emission control system in the Fuel System (DFI) chapter too.

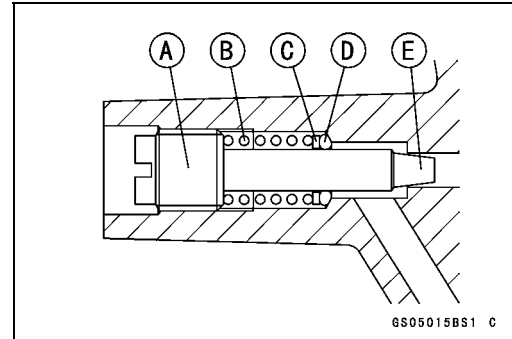

Maintenance Procedure

Idle Speed Inspection

- Start the engine and warm it up thoroughly.
- With the engine idling, turn the handlebar to both sides [A].
- ★ If handlebar movement changes the idle speed, the throttle cables may be improperly adjusted or incorrectly routed, or damaged. Be sure to correct any of these conditions before riding (see Cable, Wire, and Hose Routing section in the Appendix chapter).



⚠ WARNING

Operation with improperly adjusted, incorrectly routed, or damaged cables could result in an unsafe riding condition.

- Check the idle speed.
- ★ If the idle speed is out of specified range, adjust it.

Idle Speed

Standard: 1 100 ±50 r/min (rpm)

Idle Speed Adjustment

- Start the engine and warm it up thoroughly.
- Turn the adjusting screw [A] until the idle speed is correct.
- Open and close the throttle a few times to make sure that the idle speed is within the specified range. Readjust if necessary.

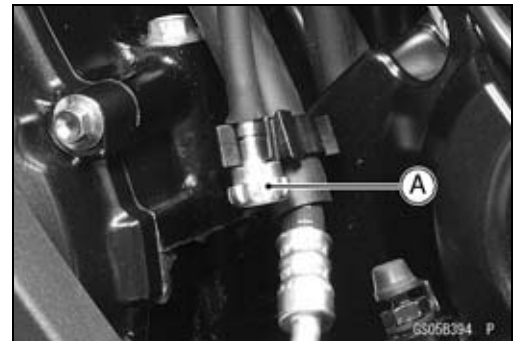

Fuel Hose Inspection (fuel leak, damage, installation condition)

○ If the motorcycle is not properly handled, the high pressure inside the fuel line can cause fuel to leak [A] or the hose to burst. Remove the fuel tank (see Fuel Tank Removal in the Fuel System (DFI) chapter) and left middle fairing (see Middle Fairing Removal in the Frame chapter), and check the fuel hose.

★ Replace the fuel hose if any fraying, cracks [B] or bulges [C] are noticed.

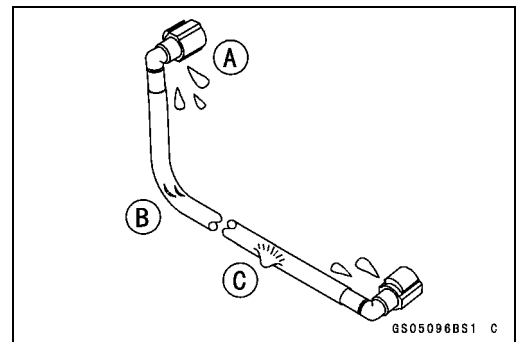

- Check that the hoses are routed according to Cable, Wire, and Hose Routing section in the Appendix chapter.

★ Replace the hose if it has been sharply bent or kinked.

Hose Joints [A]

Fuel Hose [B]

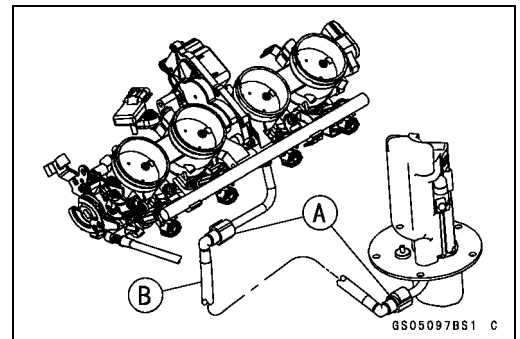

2-20 PERIODIC MAINTENANCE

Maintenance Procedure

- Check that the hose joints are securely connected.
- Push and pull [A] the hose joint [B] back and forth more than two times, and make sure it is locked.
- ★ If it does not lock, reinstall the hose joint.

⚠ WARNING

Make sure the hose joint is installed correctly on the delivery pipe by sliding the joint, or the fuel could leak.

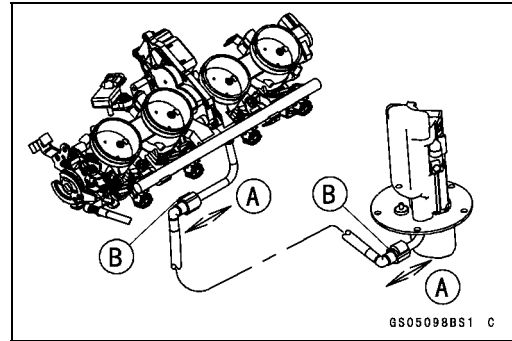

Cooling System

Coolant Level Inspection

NOTE

- Check the level when the engine is cold (room or ambient temperature).
 - Check the coolant level in the reserve tank [A] with the motorcycle held perpendicular (Do not use the sidestand).
 - ★ If the coolant level is lower than the “L” level line [B], unscrew the reserve tank cap and add coolant to the “F” level line [C].
- “L”: low
“F”: full

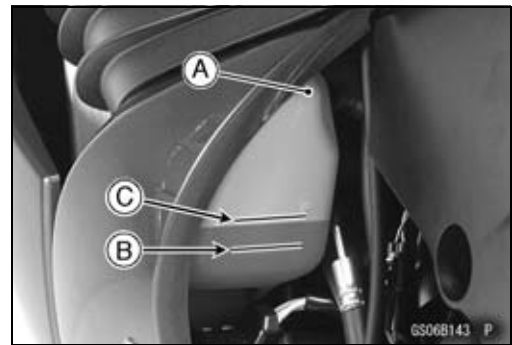

CAUTION

For refilling, add the specified mixture of coolant and soft water. Adding water alone dilutes the coolant and degrades its anticorrosion properties. The diluted coolant can attack the aluminum engine parts. In an emergency, soft water alone can be added. But the diluted coolant must be returned to the correct mixture ratio within a few days. If coolant must be added often or the reservoir tank has run completely dry, there is probably leakage in the cooling system. Check the system for leaks. Coolant ruins painted surfaces. Immediately wash away any coolant that spills on the frame, engine, wheels or other painted parts.

Radiator Hose and Pipe Inspection

(Coolant leak, damage, Installation Condition)

- The high pressure inside the radiator hose can cause coolant to leak [A] or the hose to burst if the line is not properly maintained.
- Visually inspect the hoses for signs of deterioration. Squeeze the hoses. A hose should not be hard and brittle, nor should it be soft or swollen.
- ★ Replace the hose if any fraying, cracks [B] or bulges [C] are noticed.
- Check that the hoses are securely connected and clamps are tightened correctly.

Torque - Radiator Hose Clamp Screws: 2.0 N·m (0.20 kgf·m, 18 in·lb)

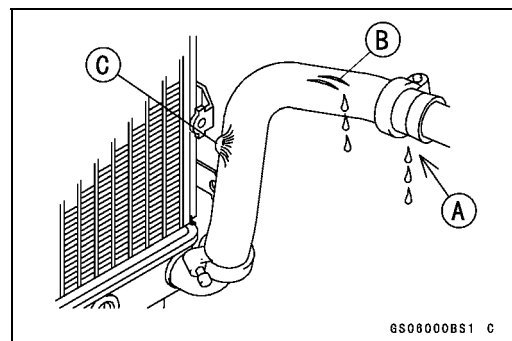

Maintenance Procedure

Evaporative Emission Control System (California Model)

Evaporative Emission Control System Inspection

- Inspect the canister as follows.
- Remove the seat (see Seat Removal in the Frame chapter).
- Remove the canister [A], and disconnect the hoses from the canister.
- Visually inspect the canister for cracks or other damage.
- ★ If the canister has any cracks or bad damage, replace it with a new one.

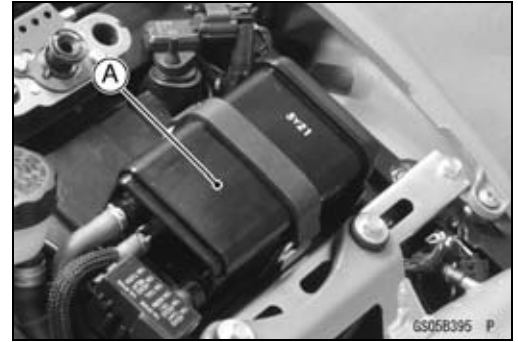

NOTE

- *The canister is designed to work well through the motorcycle's life without any maintenance if it is used under normal conditions.*

- Check the liquid/vapor separator as follows.
- Remove the fuel tank (see Fuel Tank Removal in the Fuel System (DFI) chapter).
- Disconnect the hoses from the separator, and remove the separator [A] from the motorcycle right side.
- Visually inspect the separator for cracks and other damage.
- ★ If the separator has any cracks or damage, replace it with a new one.
- To prevent the gasoline from flowing into or out of the canister, hold the separator perpendicular to the ground.
- Check the hoses of the evaporative emission control system as follows.
- Check that the hoses are securely connected and clips are in position.
- Replace any kinked, deteriorated or damaged hoses.
- Route the hoses according to Cable, Wire, and Hose Routing section in the Appendix chapter. Refer to the diagram of the evaporative emission control system in the Fuel System (DFI) chapter too.
- When installing the hoses, avoid sharp bending, kinking, flattening or twisting, and route the hoses with a minimum of bending so that the emission flow will not be obstructed.

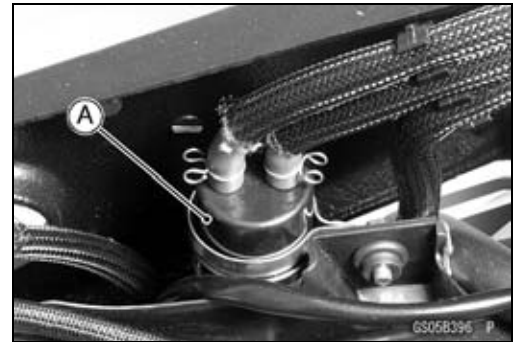

Air Suction System

Air Suction System Damage Inspection

- Remove the right middle fairing (see Middle Fairing Removal in the Frame chapter).
- Pull the air switching valve hose [A] out of the air cleaner housing.
- Start the engine and run it at idle speed.
- Plug [B] the air switching valve hose end with your finger and feel vacuum pulsing in the hose.
- ★ If there is no vacuum pulsation, check the hose line for leak. If there is no leak, check the air switching valve (see Air Switching Valve Unit Test in the Electrical System chapter) or air suction valve (see Air Suction Valve Inspection in the Engine Top End chapter).

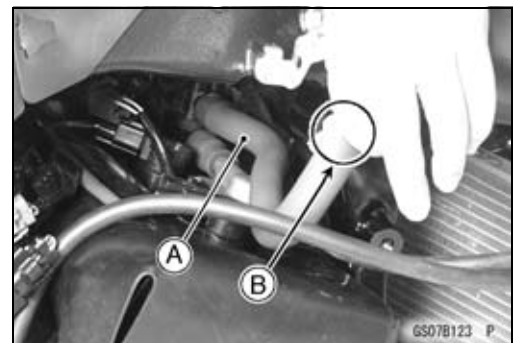

2-22 PERIODIC MAINTENANCE

Maintenance Procedure

Engine Top End

Valve Clearance Inspection

Valve Clearance Inspection

NOTE

○ Valve clearance must be checked and adjusted when the engine is cold (at room temperature).

- Remove:
 - Lower Fairings (see Lower Fairing Removal in the Frame chapter)
 - Middle Fairings (see Middle Fairing Removal in the Frame chapter)
 - Crankshaft Sensor Cover
 - Cylinder Head Cover (see Cylinder Head Cover Removal in the Engine Top End chapter)
- Position the crankshaft at 1, 4 piston TDC.
 - TDC Mark [A] for #1, 4 Pistons
 - Timing Mark [B] (crankcase halves mating surface)

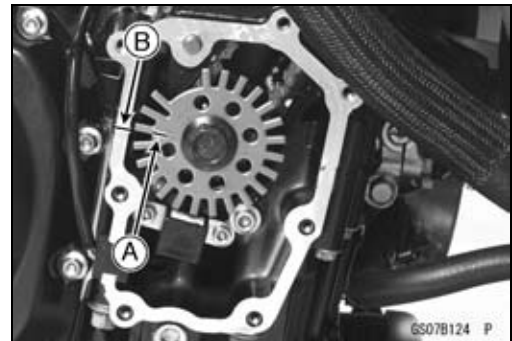

- Using a thickness gauge [A], measure the valve clearance between the cam and the valve lifter.

Valve Clearance

Standard:

Exhaust 0.22 ~ 0.27 mm (0.0087 ~ 0.0106 in.)

Inlet 0.15 ~ 0.20 mm (0.0059 ~ 0.0079 in.)

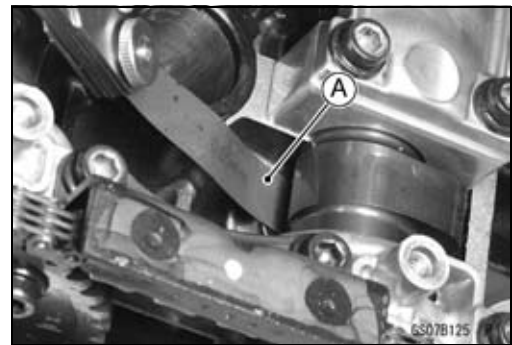

NOTE

○ Thickness gauge is horizontally inserted on the valve lifter.

Appropriateness [A]

Inadequacy [B]

Thickness Gauge [C]

Horizontally Inserts [D]

Cam [E]

Valve Lifter [F]

Hits the Valve Lifter Ahead [G]

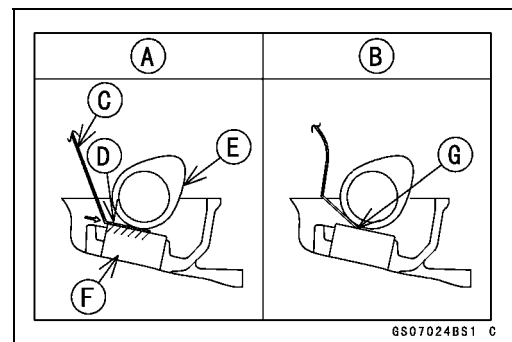

Maintenance Procedure

○When positioning #1 piston TDC at the end of the compression stroke:

- Inlet Valve Clearance of #1 and #3 Cylinders
- Exhaust Valve Clearance of #1 and #2 Cylinders
- Measuring Valve [A]

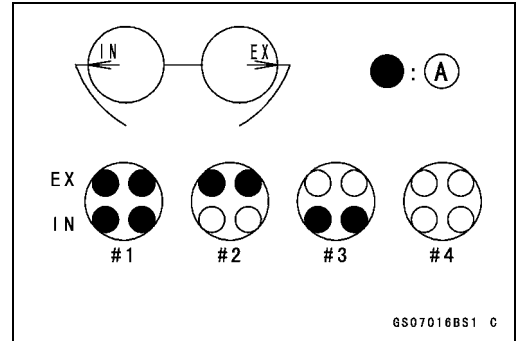

○When positioning #4 piston TDC at the end of the compression stroke:

- Inlet Valve Clearance of #2 and #4 Cylinders
- Exhaust Valve Clearance of #3 and #4 Cylinders
- Measuring Valve [A]

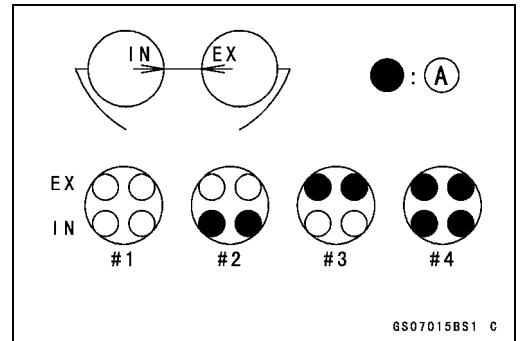

★If the valve clearance is not within the specified range, first record the clearance, and then adjust it.

Valve Clearance Adjustment

- To change the valve clearance, remove the camshaft chain tensioner, camshafts and valve lifters. Replace the shim with one of a different thickness.

NOTE

○Mark and record the locations of the valve lifters and shims so that they can be reinstalled in their original positions.

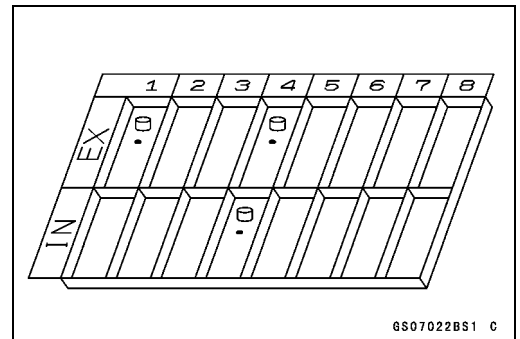

2-24 PERIODIC MAINTENANCE

Maintenance Procedure

○ Besides the standard shims in the valve clearance adjustment charts, the following additional shims may be used.

Adjustment Shims

Part Number	Thickness
92025-1982	2.425 mm
92025-1983	2.475 mm
92025-1984	2.525 mm
92025-1985	2.575 mm
92180-1058	2.375 mm
92180-1059	2.625 mm
92180-1194	2.675 mm
92180-1195	2.725 mm
92180-1196	2.775 mm
92180-0209	2.025 mm
92180-0210	2.075 mm
92180-0211	2.125 mm
92180-0212	2.175 mm
92180-0213	2.225 mm
92180-0214	2.275 mm
92180-0215	2.325 mm
92180-0216	2.825 mm
92180-0217	2.875 mm
92180-0218	2.925 mm
92180-0219	2.975 mm

- Clean the shim to remove any dust or oil.
- Measure the thickness of the removed shim [A].



Maintenance Procedure

EXHAUST- VALVE CLEARANCE ADJUSTMENT CHART

		Present Shim																		Example				
Part No. (92025)	1870	1871	1872	1873	1874	1875	1876	1877	1878	1879	1880	1881	1882	1883	1884	1885	1886	1887	1888	1889	1890			
Mark	0	5	10	15	20	25	30	35	40	45	50	55	60	65	70	75	80	85	90	95	00			
Thickness (mm)	2.00	2.05	2.10	2.15	2.20	2.25	2.30	2.35	2.40	2.45	2.50	2.55	2.60	2.65	2.70	2.75	2.80	2.85	2.90	2.95	3.00			
Valve Clearance Measurement (mm)	0.00~0.02	-	-	-	-	2.00	2.05	2.10	2.15	2.20	2.25	2.30	2.35	2.40	2.45	2.50	2.55	2.60	2.65	2.70	2.75			
	0.03~0.07	-	-	-	-	2.00	2.05	2.10	2.15	2.20	2.25	2.30	2.35	2.40	2.45	2.50	2.55	2.60	2.65	2.70	2.75	2.80		
	0.08~0.12	-	-	-	2.00	2.05	2.10	2.15	2.20	2.25	2.30	2.35	2.40	2.45	2.50	2.55	2.60	2.65	2.70	2.75	2.80	2.85		
	0.13~0.17	-	-	2.00	2.05	2.10	2.15	2.20	2.25	2.30	2.35	2.40	2.45	2.50	2.55	2.60	2.65	2.70	2.75	2.80	2.85	2.90		
	0.18~0.21	-	2.00	2.05	2.10	2.15	2.20	2.25	2.30	2.35	2.40	2.45	2.50	2.55	2.60	2.65	2.70	2.75	2.80	2.85	2.90	2.95		
	0.22~0.27	Specified Clearance/No Change Required																						
	0.28~0.32	2.05	2.10	2.15	2.20	2.25	2.30	2.35	2.40	2.45	2.50	2.55	2.60	2.65	2.70	2.75	2.80	2.85	2.90	2.95	3.00			
	0.33~0.37	2.10	2.15	2.20	2.25	2.30	2.35	2.40	2.45	2.50	2.55	2.60	2.65	2.70	2.75	2.80	2.85	2.90	2.95	3.00				
	0.38~0.42	2.15	2.20	2.25	2.30	2.35	2.40	2.45	2.50	2.55	2.60	2.65	2.70	2.75	2.80	2.85	2.90	2.95	3.00					
	0.43~0.47	2.20	2.25	2.30	2.35	2.40	2.45	2.50	2.55	2.60	2.65	2.70	2.75	2.80	2.85	2.90	2.95	3.00						
	0.48~0.52	2.25	2.30	2.35	2.40	2.45	2.50	2.55	2.60	2.65	2.70	2.75	2.80	2.85	2.90	2.95	3.00							
	0.53~0.57	2.30	2.35	2.40	2.45	2.50	2.55	2.60	2.65	2.70	2.75	2.80	2.85	2.90	2.95	3.00								
	0.58~0.62	2.35	2.40	2.45	2.50	2.55	2.60	2.65	2.70	2.75	2.80	2.85	2.90	2.95	3.00									
	0.63~0.67	2.40	2.45	2.50	2.55	2.60	2.65	2.70	2.75	2.80	2.85	2.90	2.95	3.00										
	0.68~0.72	2.45	2.50	2.55	2.60	2.65	2.70	2.75	2.80	2.85	2.90	2.95	3.00											
	0.73~0.77	2.50	2.55	2.60	2.65	2.70	2.75	2.80	2.85	2.90	2.95	3.00												
	0.78~0.82	2.55	2.60	2.65	2.70	2.75	2.80	2.85	2.90	2.95	3.00													
	0.83~0.87	2.60	2.65	2.70	2.75	2.80	2.85	2.90	2.95	3.00														
	0.88~0.92	2.65	2.70	2.75	2.80	2.85	2.90	2.95	3.00															
	0.93~0.97	2.70	2.75	2.80	2.85	2.90	2.95	3.00																
0.98~1.02	2.75	2.80	2.85	2.90	2.95	3.00																		
1.03~1.07	2.80	2.85	2.90	2.95	3.00																			
1.08~1.12	2.85	2.90	2.95	3.00																				
1.13~1.17	2.90	2.95	3.00																					
1.18~1.22	2.95	3.00																						
1.23~1.27	3.00																							

Install the shim of this thickness (mm)

GS07088BW3 C

1. Measure the clearance (with engine cold).
2. Check present shim size.
3. Match clearance in vertical column with present shim size in horizontal column.
4. Install the shim specified where the lines intersect. This shim will give the proper clearance.

Example: Present shim is **2.60 mm**.
 Measured clearance is **0.33 mm**.
 Replace **2.60 mm** shim with **2.70 mm** shim.

2-26 PERIODIC MAINTENANCE

Maintenance Procedure

INLET- VALVE CLEARANCE ADJUSTMENT CHART

		Present Shim																			Example			
Part No. (92025)		1870	1871	1872	1873	1874	1875	1876	1877	1878	1879	1880	1881	1882	1883	1884	1885	1886	1887	1888	1889	1890		
Mark		0	5	10	15	20	25	30	35	40	45	50	55	60	65	70	75	80	85	90	95	00		
Thickness (mm)		2.00	2.05	2.10	2.15	2.20	2.25	2.30	2.35	2.40	2.45	2.50	2.55	2.60	2.65	2.70	2.75	2.80	2.85	2.90	2.95	3.00		
Valve Clearance Measurement (mm)	0.00~0.05	-	-	-	2.00	2.05	2.10	2.15	2.20	2.25	2.30	2.35	2.40	2.45	2.50	2.55	2.60	2.65	2.70	2.75	2.80	2.85		
	0.06~0.10	-	-	2.00	2.05	2.10	2.15	2.20	2.25	2.30	2.35	2.40	2.45	2.50	2.55	2.60	2.65	2.70	2.75	2.80	2.85	2.90		
	0.11~0.14	-	2.00	2.05	2.10	2.15	2.20	2.25	2.30	2.35	2.40	2.45	2.50	2.55	2.60	2.65	2.70	2.75	2.80	2.85	2.90	2.95		
	0.15~0.20	Specified Clearance/No Change Required																						
	0.21~0.25	2.05	2.10	2.15	2.20	2.25	2.30	2.35	2.40	2.45	2.50	2.55	2.60	2.65	2.70	2.75	2.80	2.85	2.90	2.95	3.00			
	0.26~0.30	2.10	2.15	2.20	2.25	2.30	2.35	2.40	2.45	2.50	2.55	2.60	2.65	2.70	2.75	2.80	2.85	2.90	2.95	3.00				
	0.31~0.35	2.15	2.20	2.25	2.30	2.35	2.40	2.45	2.50	2.55	2.60	2.65	2.70	2.75	2.80	2.85	2.90	2.95	3.00					
	0.36~0.40	2.20	2.25	2.30	2.35	2.40	2.45	2.50	2.55	2.60	2.65	2.70	2.75	2.80	2.85	2.90	2.95	3.00						
	0.41~0.45	2.25	2.30	2.35	2.40	2.45	2.50	2.55	2.60	2.65	2.70	2.75	2.80	2.85	2.90	2.95	3.00							
	0.46~0.50	2.30	2.35	2.40	2.45	2.50	2.55	2.60	2.65	2.70	2.75	2.80	2.85	2.90	2.95	3.00								
	0.51~0.55	2.35	2.40	2.45	2.50	2.55	2.60	2.65	2.70	2.75	2.80	2.85	2.90	2.95	3.00									
	0.56~0.60	2.40	2.45	2.50	2.55	2.60	2.65	2.70	2.75	2.80	2.85	2.90	2.95	3.00										
	0.61~0.65	2.45	2.50	2.55	2.60	2.65	2.70	2.75	2.80	2.85	2.90	2.95	3.00											
	0.66~0.70	2.50	2.55	2.60	2.65	2.70	2.75	2.80	2.85	2.90	2.95	3.00												
	0.71~0.75	2.55	2.60	2.65	2.70	2.75	2.80	2.85	2.90	2.95	3.00													
	0.76~0.80	2.60	2.65	2.70	2.75	2.80	2.85	2.90	2.95	3.00														
0.81~0.85	2.65	2.70	2.75	2.80	2.85	2.90	2.95	3.00																
0.86~0.90	2.70	2.75	2.80	2.85	2.90	2.95	3.00																	
0.91~0.95	2.75	2.80	2.85	2.90	2.95	3.00																		
0.96~1.00	2.80	2.85	2.90	2.95	3.00																			
1.01~1.05	2.85	2.90	2.95	3.00																				
1.06~1.10	2.90	2.95	3.00																					
1.11~1.15	2.95	3.00																						
1.16~1.20	3.00																							

Install the shim of this thickness (mm)

GS07090BW3 C

1. Measure the clearance (with engine cold).
2. Check present shim size.
3. Match clearance in vertical column with present shim size in horizontal column.
4. Install the shim specified where the lines intersect. This shim will give the proper clearance.

Example: Present shim is **2.55 mm**.
 Measured clearance is **0.36 mm**.
 Replace **2.55 mm** shim with **2.75 mm** shim.

Maintenance Procedure

CAUTION

Be sure to remeasure the clearance after selecting a shim according to the table. If the clearance is out of the specified range, use the additional shim.

- If there is no valve clearance, use a shim that is a few sizes smaller, and remeasure the valve clearance.
- When installing the shim, face the marked side toward the valve lifter. At this time, apply engine oil to the shim or the valve lifter to keep the shim in place during camshaft installation.

CAUTION

Do not put shim stock under the shim. This may cause the shim to pop out at high rpm, causing extensive engine damage.
Do not grind the shim. This may cause it to fracture, causing extensive engine damage.

- Apply engine oil to the valve lifter surface and install the lifter.
- Install the camshaft (see Camshaft Installation in the Engine Top End chapter).
- Recheck the valve clearance and readjust if necessary.
- Install the removed parts (see appropriate chapters).

Clutch and Drive Train

Clutch Operation Inspection

- Start the engine and check that the clutch does not slip and that it releases properly.
- ★ If the clutch operation is insufficiency, inspect the clutch system.

⚠ WARNING

When inspecting by running the vehicle, note a surrounding traffic situation enough in the place of safety.

Clutch Fluid Level Inspection

- Hold the clutch fluid reservoir [A] horizontal.
- Check that the clutch fluid level of the clutch reservoir is between the lower [B] and the upper [C] level lines.
- ★ If the fluid level is lower than the lower level line, fill the reservoir to the upper level line in the reservoir.
- Since the clutch fluid is the same as the brake fluid, refer to Brake Fluid Section in the Brake chapter for further details.

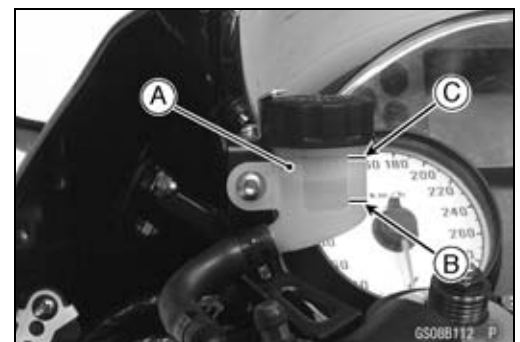

2-28 PERIODIC MAINTENANCE

Maintenance Procedure

- Follow the procedure below to instal the clutch fluid reservoir cap correctly.
- First, tighten the clutch fluid reservoir cap [B] clockwise [C] by hand until the resistance is felt fully; then, tighten the cap an additional 1/6 turn [D] while holding the clutch fluid reservoir body [A].

⚠ WARNING

Change the fluid in the clutch line completely if the fluid must be refilled but the type and brand of the fluid that already is in the reservoir are unidentified. After changing the fluid, use only the same type and brand of fluid thereafter.

Clutch Fluid Leak Inspection

- Apply the clutch lever and inspect the clutch fluid leak from the clutch hose/pipe [A] and fittings.
- ★ If the clutch fluid leaked form any position, inspect or replace the problem part.

Clutch Hose and Pipe Damage and Installation Condition Inspection

- Inspect the clutch hoses and fittings for deterioration, cracks, corrosion and signs of leakage.
- The high pressure inside the clutch line can cause fluid to leak [A] or the hose to burst if the line is not properly maintained. Bend and twist the rubber hose while examining it.
- ★ Replace it if any fraying, cracks [B] or bulges [C] are noticed.
- Check that the hoses are securely connected and banjo bolts are tightened correctly.

Torque - Clutch Hose Banjo Bolts: 25 N·m (2.5 kgf·m, 18 ft·lb)

- Inspect the clutch hose routing.
- ★ If any clutch hose routing is incorrect, route the hoses according to Cable, Wire, and Hose Routing section in the Appendix chapter.
- ★ Replace the hose if the has been sharply bent or kinked.

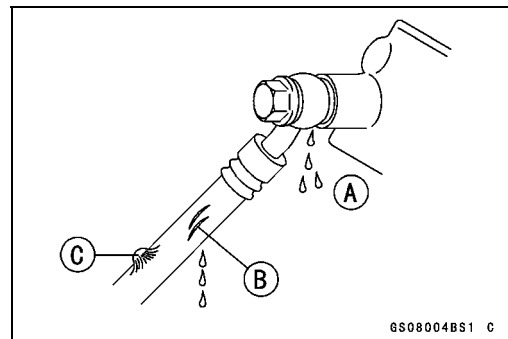
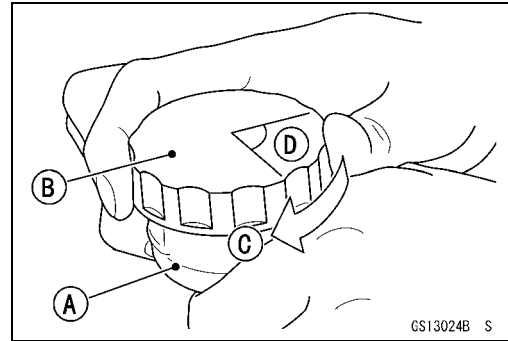

Maintenance Procedure

Wheels/Tires

Air Pressure Inspection

- Remove the air valve cap.
- Measure the tire air pressure with an air pressure gauge [A] when the tires are cold (that is, when the motorcycle has not been ridden more than a mile during the past 3 hours).
- Install the air valve cap.
- ★ Adjust the tire air pressure according to the specifications if necessary.

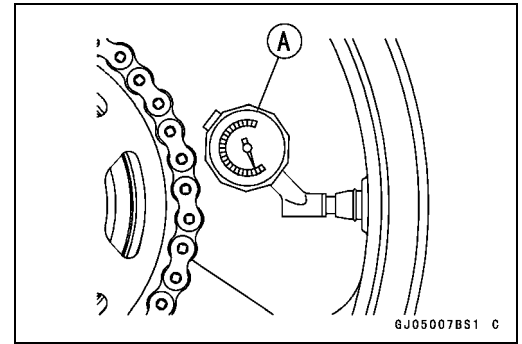

Air Pressure (when Cold)

- Front: Up to 180 kg (397 lb)**
290 kPa (2.9 kgf/cm², 42 psi)
- Rear: Up to 180 kg (397 lb)**
290 kPa (2.9 kgf/cm², 42 psi)

Wheel/Tire Damage Inspection

- Remove any imbedded stones [A] or other foreign particles [B] from tread.
- Visually inspect the tire for cracks and cuts, and replace the tire if necessary. Swelling or high spots indicate internal damage, requiring tire replacement.
- Visually inspect the wheel for cracks, cuts and dents damage.
- ★ If any damage is found, replace the wheel if necessary.

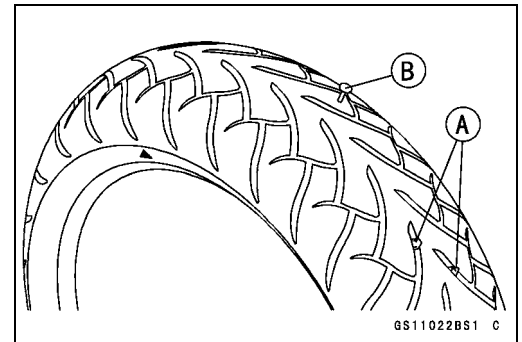

Tire Tread Wear Inspection

As the tire tread wears down, the tire becomes more susceptible to puncture and failure. An accepted estimate is that 90% of all tire failures occur during the last 10% of tread life (90% worn). So it is false economy and unsafe to use the tires until they are bald.

- Measure the tread depth at the center of the tread with a depth gauge [A]. Since the tire may wear unevenly, take measurement at several places.
- ★ If any measurement is less than the service limit, replace the tire (see Tire Removal/Installation in the Wheels/Tires chapter).

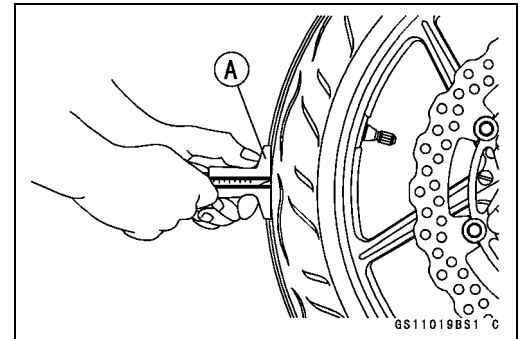

Tread Depth

Standard:

- Front 3.8 mm (0.15 in.)**
- Rear 4.8 mm (0.19 in.)**

Service Limit:

- Front 1 mm (0.04 in.)**
(AT, CH, DE) 1.6 mm (0.06 in.)
- Rear 2 mm (0.08 in.)**
(Up to 130 km/h (80 mph))
3 mm (0.12 in.)
(Over 130 km/h (80 mph))

2-30 PERIODIC MAINTENANCE

Maintenance Procedure

⚠ WARNING

To ensure safe handling and stability, use only the recommended standard tires for replacement, inflated to the standard pressure.

NOTE

- Most countries may have their own regulations a minimum tire tread depth: be sure to follow them.
- Check and balance the wheel when a tire is replaced with a new one.

Wheel Bearing Damage Inspection

- Raise the front wheel off the ground with the jack (see Front Wheel Removal in the Wheels/Tires chapter).
 - Turn the handlebar all the way to the right or left.
 - Inspect the roughness of the front wheel bearing by pushing and pulling [A] the wheel.
 - Spin [B] the front wheel lightly, and check for smoothly turn, roughness, binding or noise.
 - ★ If roughness, binding or noise is found, remove the front wheel and inspect the wheel bearing (see Front Wheel Removal, Hub Bearing Inspection in the Wheels/Tires chapter).
-
- Raise the rear wheel off the ground with the stand (see Rear Wheel Removal in the Wheels/Tires chapter).
 - Inspect the roughness of the rear wheel bearing by pushing and pulling [A] the wheel.
 - Spin [B] the rear wheel lightly, and check for smoothly turn, roughness, binding or noise.
 - ★ If roughness, binding or noise is found, remove the rear wheel and inspect the wheel bearing (see Rear Wheel Removal, Hub Bearing Inspection in the Wheels/Tires chapter) and coupling (see Coupling Bearing Inspection in the Final Drive chapter).

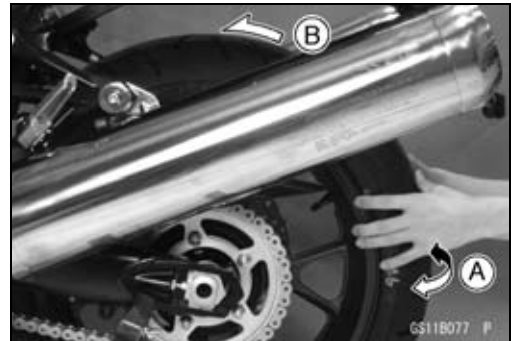
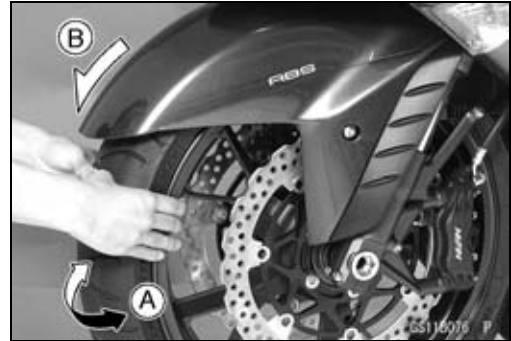

Drive Train

Drive Chain Lubrication Condition Inspection

- If a special lubricant is not available, a heavy oil such as SAE 90 is preferred to a lighter oil because it will stay on the chain longer and provide better lubrication.
- If the chain appears especially dirty, clean it before lubrication.

CAUTION

The O-rings between the side plates seal in the lubricant between the pin and the bushing. To avoid damaging the O-rings and resultant loss of lubricant, observe the following rules.

Use only kerosene or diesel oil for cleaning of the O-ring of the drive chain. Any other cleaning solution such as gasoline or trichloroethylene will cause deterioration and swelling of the O-ring. Immediately blow the chain dry with compressed air after cleaning. Complete cleaning and drying the chain within 10 minutes.

Maintenance Procedure

- Apply oil to the sides of the rollers so that oil will penetrate to the rollers and bushings. Apply the oil to the O-rings so that the O-rings will be coated with oil.
- Wipe off any excess oil.
 - Oil Applied Areas [A]
 - O-ring [B]

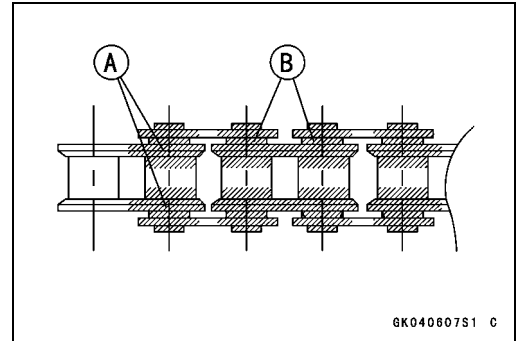

Drive Chain Slack Inspection

NOTE

- Check the slack with the motorcycle setting on its side stand.
- Check the slack with the motorcycle setting on its center stand (center stand equipped models).
- Clean the chain if it is dirty, and lubricate it if it appears dry.
- Check the wheel alignment (see Wheel Alignment Inspection).
- Rotate the rear wheel to find the position where the chain is tightest.
- Measure the vertical movement (chain slack) [A] midway between the sprockets.
- ★ If the chain slack exceeds the standard, adjust it.

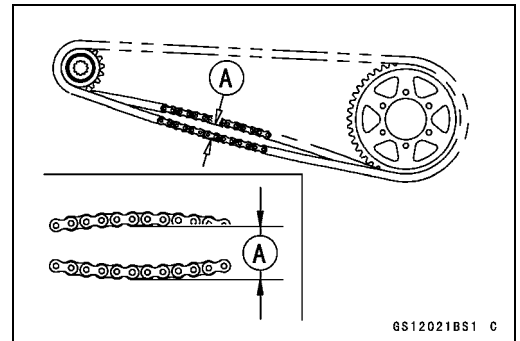

Chain Slack

Standard: 32 ~ 38 mm (1.3 ~ 1.5 in.)

Drive Chain Slack Adjustment

- Remove the cotter pin [A], and loosen the axle nut [B].
- Loosen the both chain adjuster locknuts [C].
- ★ If the chain is too loose, turn out the right and left chain adjusters [D] evenly.
- ★ If the chain is too tight, turn in the right and left chain adjusters evenly, and kick the wheel forward.
- Turn both chain adjusters evenly until the drive chain has the correct amount of slack. To keep the chain and wheel properly aligned, the notch [E] on the right wheel alignment indicator [F] should align with the same swingarm mark or position [G] that the left indicator notch aligns with.

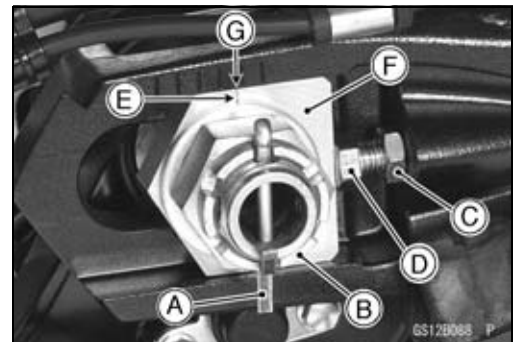

⚠ WARNING

Misalignment of the wheel will result in abnormal wear and may result in an unsafe riding condition.

- Tighten both chain adjuster locknuts securely.
- Tighten the axle nut.
 - Torque - Rear Axle Nut: 127 N·m (13.0 kgf·m, 94 ft·lb)**
- Turn the wheel, measure the chain slack again at the tightest position, and readjust if necessary.

2-32 PERIODIC MAINTENANCE

Maintenance Procedure

- Insert a new cotter pin [A].

NOTE

- When inserting the cotter pin, if the slots in the nut do not align with the cotter pin hole in the axle, tighten the nut clockwise [B] up to next alignment.
- It should be within 30°.
- Loosen once and tighten again when the slot goes past the nearest hole.

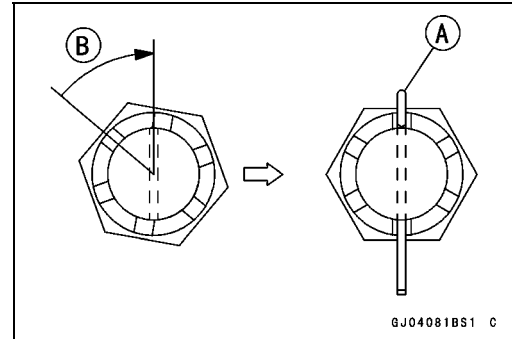

- Bend the cotter pin [A] over the nut.

⚠ WARNING

If the rear axle nut is not securely tightened or the cotter pin is not installed, an unsafe riding condition may result.

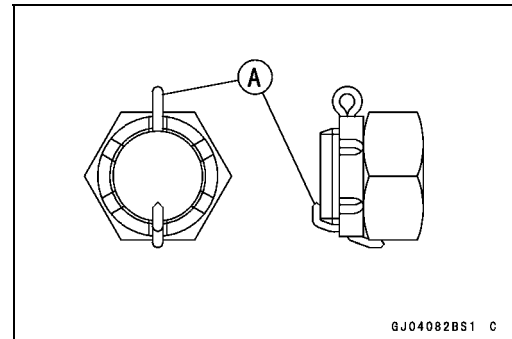

Wheel Alignment Inspection

- Check that the notch [A] on the right alignment indicator [B] aligns with the same swingarm mark or position [C] that the left alignment indicator notch aligns with.
- ★ If they do not, adjust the chain slack and align the wheel alignment (see Drive Chain Slack Adjustment).

NOTE

- Wheel alignment can be also checked using the straightedge or string method.

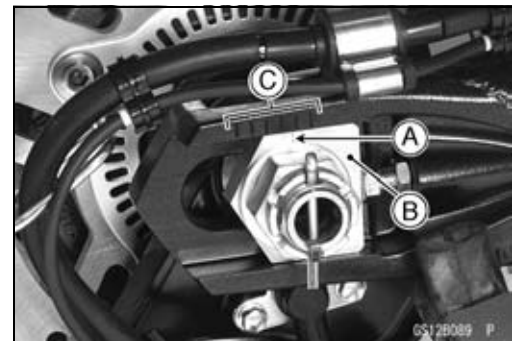

⚠ WARNING

Misalignment of the wheel will result in abnormal wear, and may result in an unsafe riding condition.

Drive Chain Wear Inspection

- Remove the chain cover (see Drive Chain Removal in the Final Drive chapter).
- Rotate the rear wheel to inspect the drive chain for damaged rollers, and loose pins and links.
- ★ If there is any irregularity, replace the drive chain.
- ★ Lubricate the drive chain if it appears dry.
- Stretch the chain taut by hanging a 98 N (10 kg, 20 lb) weight [A] on the chain.
- Measure the length of 20 links [B] on the straight part [C] of the chain from the pin center of the 1st pin to the pin center of the 21st pin. Since the chain may wear unevenly, take measurements at several places.
- ★ If any measurements exceed the service limit, replace the chain. Also, replace the front and rear sprockets when the drive chain is replaced.

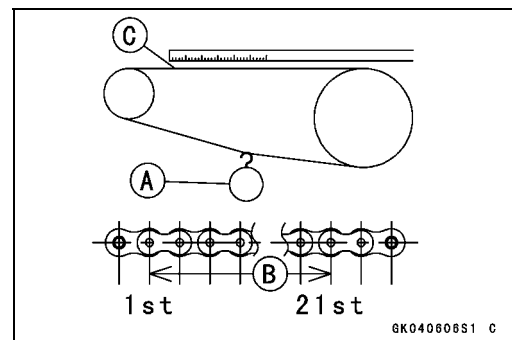

Drive Chain 20-link Length

Standard: 317.5 ~ 318.2 mm (12.50 ~ 12.53 in.)

Service Limit: 323 mm (12.7 in.)

Maintenance Procedure**⚠ WARNING**

If the drive chain wear exceeds the service limit, replace the chain or an unsafe riding condition may result. A chain that breaks or jumps off the sprockets could snag on the engine sprocket or lock the rear wheel, severely damaging the motorcycle and causing it to go out of control.

For safety, use only the standard chain. It is an endless type and should not be cut for installation.

Standard Chain

Make: DAIDO

Type: DID50ZVM4 GC&B

Link: 116 links

Chain Guide Wear Inspection

- Remove the swingarm (see Swingarm Removal in the Suspension chapter).
- Visually inspect the chain guide [A].
- ★ Replace the chain guide if it shows any signs of abnormal wear or damage.

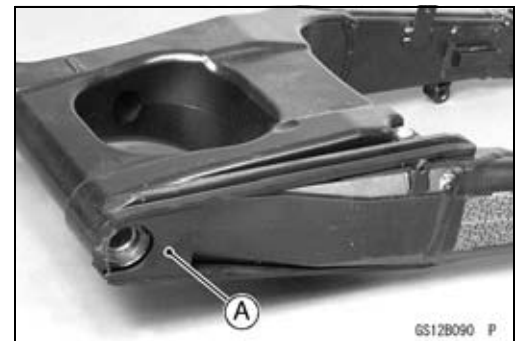

2-34 PERIODIC MAINTENANCE

Maintenance Procedure

Brake System

Brake Fluid Leak (Brake Hose and Pipe) Inspection

- For ABS equipped models; note the following.
- Remove:
 - Fuel Tank (see Fuel Tank Removal in the Fuel System (DFI) chapter)
 - Battery (see Battery Removal in the Electrical System chapter)
- Apply the brake lever or pedal and inspect the brake fluid leak from the brake hoses [A], pipes (ABS equipped models) [B] and fittings [C].
- ★ If the brake fluid leaked from any position, inspect or replace the problem part.

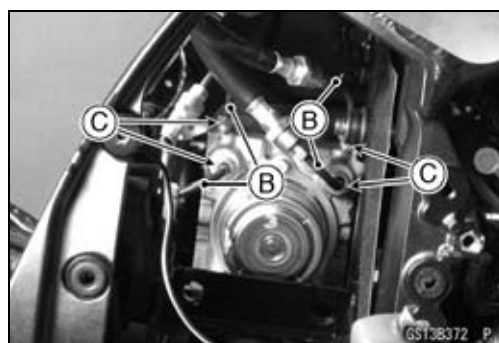
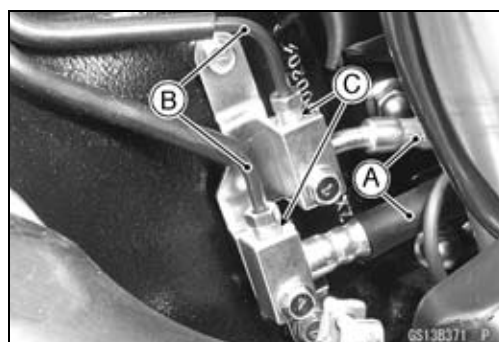
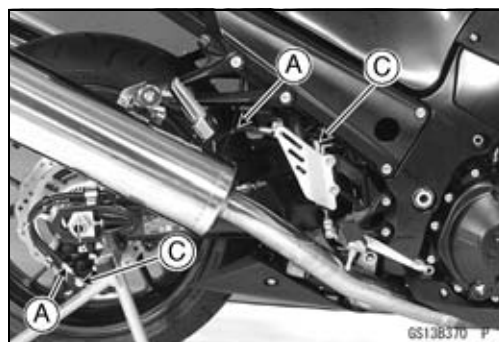
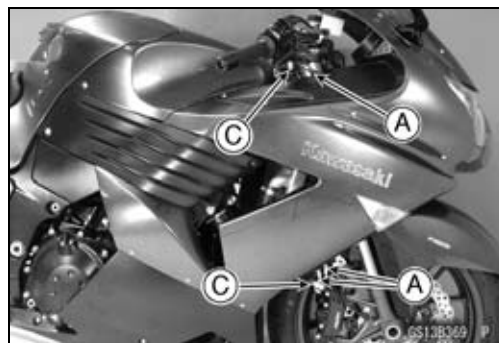

Maintenance Procedure

Brake Hose and Pipe Damage and Installation Condition Inspection

- For ABS equipped models; note the following.
- Remove:
 - Fuel Tank (see Fuel Tank Removal in the Fuel System (DFI) chapter)
 - Battery (see Battery Removal in the Electrical System chapter)
- Inspect the brake hoses and fittings for deterioration, cracks and signs of leakage.
- The high pressure inside the brake line can cause fluid to leak [A] or the hose, pipes (ABS equipped models) to burst if the line is not properly maintained. Bend and twist the rubber hose while examining it.
- ★ Replace the hose and pipe (ABS equipped models) if any crack [B], bulge [C] or leakage is noticed.
- ★ Tighten any brake hose banjo bolts.

Torque - Brake Hose Banjo Bolts: 25 N·m (2.5 kgf·m, 18 ft·lb)

- Inspect the brake hose routing.
- ★ If any brake hose and pipe (ABS equipped models) routing is incorrect, route the brake hose and pipe according to Cable, Wire, and Hose Routing section in the Appendix chapter.

Brake Operation Inspection

- Inspect the operation of the front and rear brake by running the vehicle on the dry road.
- ★ If the brake operation is insufficiency, inspect the brake system.

⚠ WARNING

When inspecting by running the vehicle, note a surrounding traffic situation enough in the place of safety.

Brake Fluid Level Inspection

- Check that the brake fluid level in the front brake reservoir [A] is above the lower level line [B].

NOTE

○ Hold the reservoir horizontal by turning the handlebar when checking brake fluid level.

- ★ If the fluid level is lower than the lower level line, fill the reservoir to the upper level line [C].

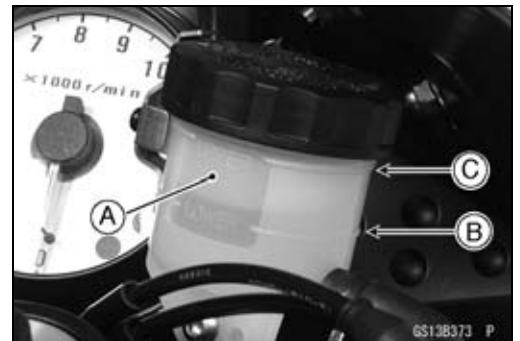
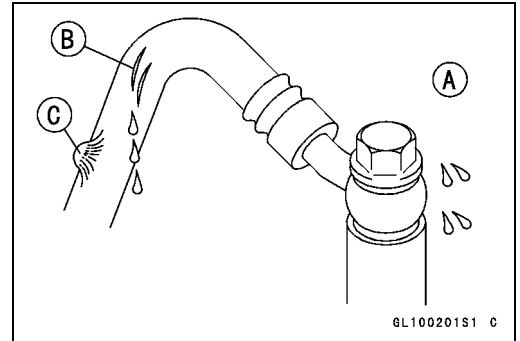

2-36 PERIODIC MAINTENANCE

Maintenance Procedure

- Follow the procedure below to install the front brake fluid reservoir cap correctly.

○ First, tighten the front brake fluid reservoir cap [B] clockwise [C] by hand until slight resistance is felt indicating that the cap is seated on the reservoir body, then tighten the cap an additional 1/6 turn [D] while holding the brake fluid reservoir body [A].

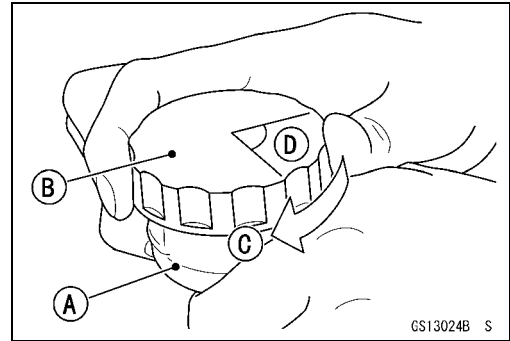

- Remove the seat (see Seat Removal in the Frame chapter).
- Check that the brake fluid level in the rear brake reservoir [A] is above the lower level line [B].
- ★ If the fluid level is lower than the lower level line, fill the reservoir to the upper level line [C].

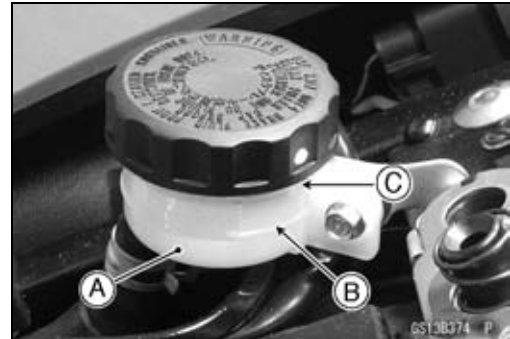

⚠ WARNING

Change the brake fluid in the brake line completely if the brake fluid must be refilled but the type and brand of the brake fluid that is already in the reservoir are unidentified. After changing the fluid, use only the same type and brand of fluid thereafter.

Recommended Disc Brake Fluid

Grade: DOT4

- Follow the procedure below to install the rear brake fluid reservoir cap correctly.

○ First, tighten the rear brake fluid reservoir cap [B] clockwise [C] by hand until slight resistance is felt indicating that the cap is seated on the reservoir body, then tighten the cap an additional 1/6 turn [D] while holding the brake fluid reservoir body [A].

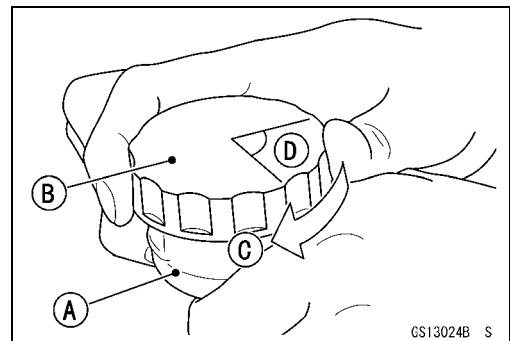

Brake Pad Wear Inspection

- Remove the brake pads (see Front/Rear Brake Pad Removal in the Brakes chapter).
- Check the lining thickness [A] of the pads in each caliper.
- ★ If the lining thickness of either pad is less than the service limit [B], replace both pads in the caliper as a set.

Pad Lining Thickness

Standard:

Front 4.0 mm (0.16 in.)

Rear 5.0 mm (0.20 in.)

Service Limit: 1 mm (0.04 in.)

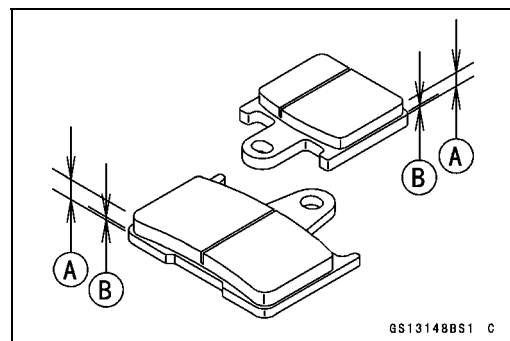

Maintenance Procedure

Brake Light Switch Operation Inspection

- Turn on the ignition switch.
- The brake light [A] should go on when the brake lever is applied or after the brake pedal is depressed about 10 mm (0.39 in.).



- ★ If it does not, adjust the brake light switch.
- While holding the switch body, turn the adjusting nut to adjust the switch.
 - Switch Body [A]
 - Adjusting Nut [B]
 - Light sooner as the body rises [C]
 - Light later as the body lowers [D]

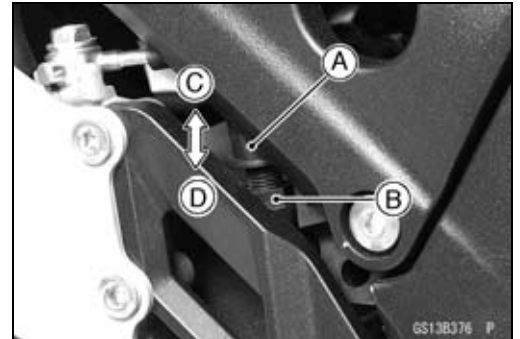

CAUTION

To avoid damaging the electrical connections inside the switch, be sure that the switch body does not turn during adjustment.

- ★ If it does not go on, inspect or replace the following items.
 - Battery (see Charging Condition Inspection in the Electrical System chapter)
 - Brake Light (see Tail/Brake Light Removal in the Electrical System chapter)
 - Main Fuse 30 A and Taillight Fuse 10 A (see Fuse Inspection in the Electrical System chapter)
 - Front Brake Light Switch [A] (see Switch Inspection in the Electrical System chapter)
 - Rear Brake Light Switch (see Switch Inspection in the Electrical System chapter)
 - Harness (see Wiring Inspection in the Electrical System chapter)



Suspensions

Front Forks/Rear Shock Absorber Operation Inspection

- Pump the forks down and up [A] 4 or 5 times, and inspect the smooth stroke.
- ★ If the forks do not smoothly or noise is found, inspect the fork oil level or fork clamps (see Front Fork Oil Change in the Suspension chapter).



2-38 PERIODIC MAINTENANCE

Maintenance Procedure

- Pump the seat down and up [A] 4 or 5 times, and inspect the smooth stroke.
- ★ If the shock absorber does not smoothly stroke or noise is found, inspect the oil leak (see Rear Shock Absorber Oil Leak Inspection).



Front Fork Oil Leak Inspection

- Visually inspect the front forks [A] for oil leakage.
- ★ Replace or repair any defective parts, if necessary.



Rear Shock Absorber Oil Leak Inspection

- Visually inspect the shock absorber [A] for oil leakage.
- ★ If the oil leakage is found on it, replace the shock absorber with a new one.



Rocker Arm Operation Inspection

- Remove the rear fairing (see Rear Fairing Removal in the Frame chapter).
- Pump the seat down and up 4 or 5 times, and inspect the smooth stroke.
- ★ If the rocker arm [A] does not smoothly stroke or noise is found, inspect the fasteners and bearings (see Rocker Arm/Tie-Rod Bearing, Sleeve Inspection in the Suspension chapter).

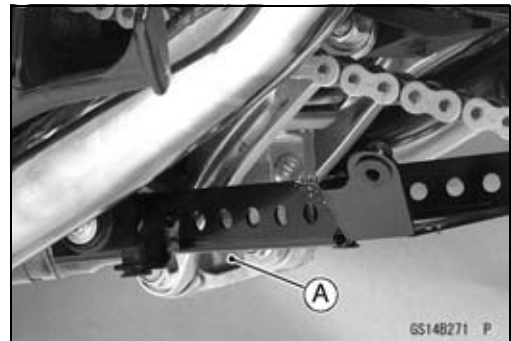

Tie-Rod Operation Inspection

- Remove the rear fairing (see Rear Fairing Removal in the Frame chapter).
- Pump the seat down and up 4 or 5 times, and inspect the smooth stroke.
- ★ If the tie-rods [A] do not smoothly stroke or noise is found, inspect the fasteners and tie-rod bearings (see Rocker Arm/Tie-Rod Bearing, Sleeve Inspection in the Suspension chapter).



Maintenance Procedure

Steering System

Steering Play Inspection

- Remove the lower fairings (see Lower Fairing Removal in the Frame chapter).
- Raise the front wheel off the ground with the jack.

Special Tools - Jack: 57001-1238

Jack Attachment: 57001-1608

- With the front wheel pointing straight ahead, alternately tap each end of the handlebar. The front wheel should swing fully left and right from the force of gravity until the fork hits the stop.
- ★ If the wheel binds or catches before the stop, the steering is too tight.
- Feel for steering looseness by pushing and pulling the forks.
- ★ If you feel looseness, the steering is too loose.

NOTE

- *The cables and wiring will have some effect on the motion of the fork which must be taken into account.*
- *Be sure the leads and cables are properly routed.*
- *The bearings must be in good condition and properly lubricated in order for any test to be valid.*

Steering Play Adjustment

- Remove:
 - Handlebars (see Handlebar Removal in the Steering chapter)
 - Stem Head Nut [A] and Washer [B]
 - Upper Fork Clamp Bolts [C] (Loosen)
 - Stem Head [D]

- Bend the claws [A] of the claw washer straighten.
- Remove the steering stem locknut [B] and claw washer [C].

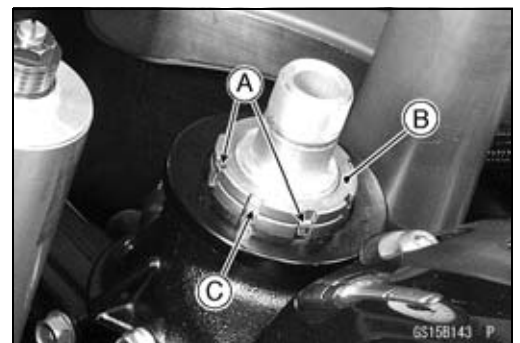
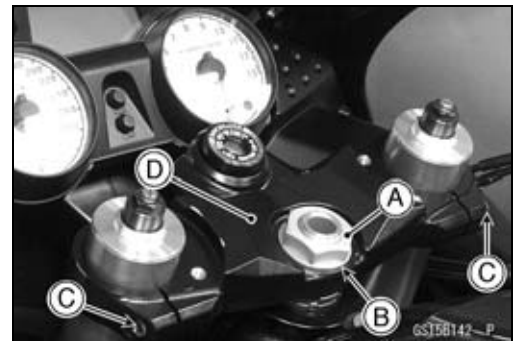

2-40 PERIODIC MAINTENANCE

Maintenance Procedure

- Adjust the steering.

Special Tool - Steering Stem Nut Wrench [A]: 57001-1100

- ★ If the steering is too tight, loosen the stem nut a fraction of a turn.
- ★ If the steering is too loose, tighten the stem nut a fraction of a turn.

NOTE

○ Turn the stem nut 1/8 turn at time maximum.

- Install the claw washer [A] so that its bent side [B] faces upward, and engage the bent claws with the grooves of stem locknut [C].
- Hand tighten the stem locknut until it touches the claw washer.
- Tighten the stem locknut clockwise until the claws are aligned with the grooves (ranging from 2nd to 4th) of stem nut [D], and bend the 2 claws downward [E].
- Install the stem head.
- Install the washer, and tighten the stem head nut.
- Tighten:

Torque - Upper Front Fork Clamp Bolts: 20 N·m (2.0 kgf·m, 15 ft·lb)

Steering Stem Head Nut: 78 N·m (8.0 kgf·m, 58 ft·lb)

- Check the steering again.
- ★ If the steering is still too tight or too loose, repeat the adjustment.
- Install the handlebars (see Handlebar Installation in the Steering chapter).

Steering Stem Bearing Lubrication

- Remove the steering stem (see Stem, Stem Bearing Removal in the Steering chapter).
- Using a high-flash point solvent, wash the upper and lower ball bearings in the cages, and wipe the upper and lower outer races, which are press-fitted into the frame head pipe, clean off grease and dirt.
- Visually check the outer races and the ball bearings.
- ★ Replace the bearing assemblies if they show wear or damage.
- Pack the upper and lower ball bearings [A] in the cages with grease, and apply a light coat of grease to the upper and lower outer races.
- Install the steering stem (see Stem, Stem Bearing Installation in the Steering chapter).
- Adjust the steering (see Steering Play Adjustment).

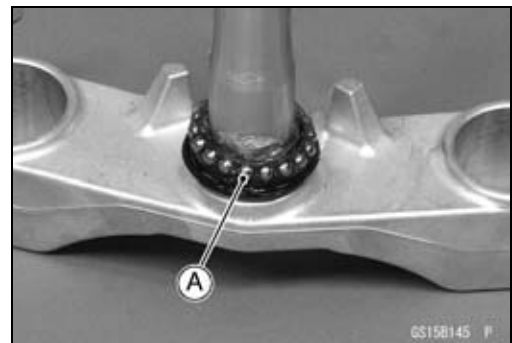
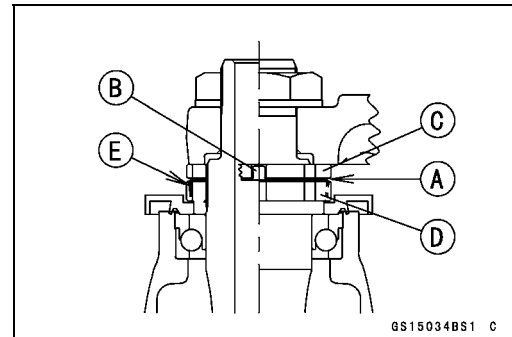

Maintenance Procedure

Electrical System

Lights and Switches Operation Inspection

First Step

- Turn on the ignition switch.
- The following lights should go on according to below table.

City Light [A]	goes on
Taillight [B]	goes on
License Plate Light [C]	goes on
Meter Panel Illumination Light (LED) [D]	goes on
Meter Panel LCD [E]	goes on
Neutral Indicator Light (LED) [F]	goes on
Oil Pressure Warning Indicator Light (LED) [G]	goes on
ABS Indicator Light (LED) [H] (Equipped Models)	goes on

★ If the light does not go on, inspect or replace the following item.

Battery (see Charging Condition Inspection in the Electrical System chapter)

Applicable Bulb (see Wiring Diagram in the Electrical System chapter)

Meter Unit for Meter Panel LCD (see Meter Unit Inspection in the Electrical System chapter)

Meter Unit for Neutral Indicator Light (LED) (see Meter Unit Inspection in the Electrical System chapter)

Meter Unit for Warning Indicator Light (LED) (see Meter Unit Inspection in the Electrical System chapter)

Meter Unit for Oil Pressure Warning Indicator Light (LED) (see Meter Unit Inspection in the Electrical System chapter)

Meter Unit for Illumination Light (LED) (see Meter Unit Inspection in the Electrical System chapter)

ECU (see ECU Power Supply Inspection in the Fuel System (DFI) chapter)

Main Fuse 30 A and Taillight Fuse 10 A (see Fuse Inspection in the Electrical System chapter)

Ignition Switch (see Switch Inspection in the Electrical System chapter)

Gear Position Switch (see Gear Position Switch Inspection in the Electrical System chapter)

Harness (see Wiring Inspection in the Electrical System chapter)

ABS Indicator Light (LED) (Equipped Models) (see ABS Indicator Light (LED) Inspection in the Brakes chapter)

- Turn off the ignition switch.
- The all lights should go off.
- For the immobilizer model, Warning Indicator Light (LED) will blinks (see Immobilizer System (Equipped Models) section in the Electrical System chapter).

★ If the light does not go off, replace the ignition switch.

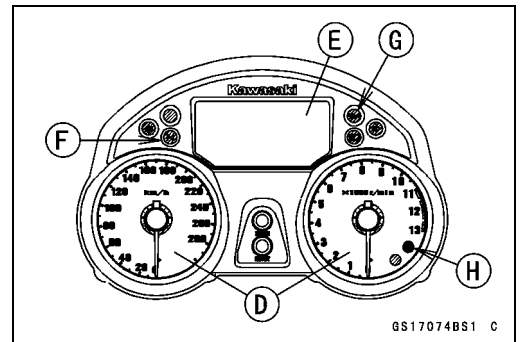
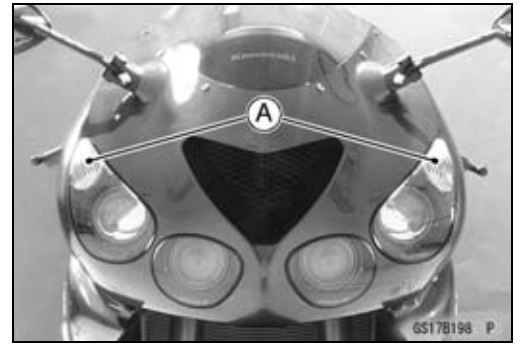

2-42 PERIODIC MAINTENANCE

Maintenance Procedure

Second Step

- Turn the ignition switch to P (Park) position.
- The city light, taillight and license plate light should go on.
- ★ If the light does not go on, inspect or replace the following item.

Ignition Switch (see Switch Inspection in the Electrical System chapter)

Third Step

- Turn on the ignition switch.
- Turn on the turn signal switch [A] (left or right position).
- The left or right turn signal lights [B] (front and rear) according to the switch position should flash.
- The either of turn signal indicator lights (LED) [C] in the meter unit should flash.
- ★ If the each light does not flash, inspect or replace the following item.

Turn Signal Light Bulb (see Turn Signal Light Bulb Replacement in the Electrical System chapter)

Meter Unit for Turn Signal Indicator Light (LED) (see Meter Unit Inspection in the Electrical System chapter)

Turn Signal Relay Fuse 10 A (see Fuse Inspection in the Electrical System chapter)

Turn Signal Switch (see Switch Inspection in the Electrical System chapter)

Turn Signal Relay (see Turn Signal Relay Inspection in the Electrical System chapter)

Harness (see Wiring Inspection in the Electrical System chapter)

- Push the turn signal switch.
- The turn signal lights and indicator light (LED) should go off.
- ★ If the light does not go off, inspect or replace the following item.

Turn Signal Switch (see Switch Inspection in the Electrical System chapter)

Turn Signal Relay (see Turn Signal Relay Inspection in the Electrical System chapter)

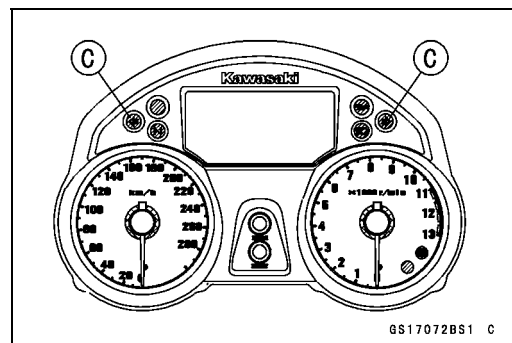

Maintenance Procedure

Fourth Step

- Set the dimmer switch [A] to low beam position.
- Start the engine.
- The low beam headlights [B] should go on.
- ★ If the low beam headlight does not go on, inspect or replace the following item.

Headlight Low Beam Bulb (see Headlight Bulb Replacement in the Electrical System chapter)

Headlight Fuse (Low) 15 A (see Fuse Inspection in the Electrical System chapter)

Headlight Relay Fuse 10 A (see Fuse Inspection in the Electrical System chapter)

Headlight Circuit Relay in Relay Box (see Relay Circuit Inspection in the Electrical System chapter)

Headlight Relay (Low) (see Headlight Relay Inspection in the Electrical System chapter)

Harness (see Wiring Inspection in the Electrical System chapter)

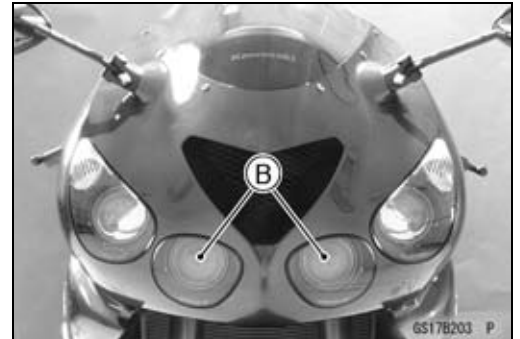
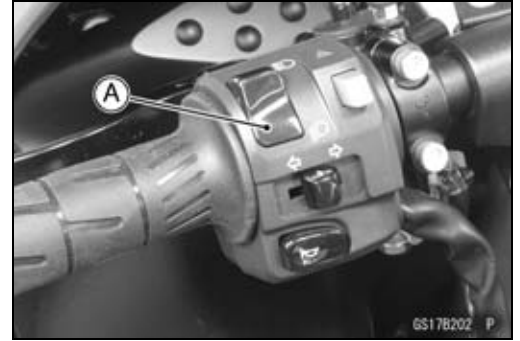

- Push the passing button (equipped models) or set the dimmer switch to high beam position.
- The low beam [A] and high beam [B] headlights should go on.
- The high beam indicator light (LED) [C] should go on.
- ★ If the high beam headlight and/or high beam indicator light (LED) does not go on, inspect or replace the following item.

Headlight High Beam Bulb (see Headlight Bulb Replacement in the Electrical System chapter)

Headlight Fuse (High) 15 A (see Fuse Inspection in the Electrical System chapter)

Headlight Relay Fuse 10 A (see Fuse Inspection in the Electrical System chapter)

Passing Button (Equipped Models) (see Switch Inspection in the Electrical system chapter)

Dimmer Switch (see Switch Inspection in the Electrical System chapter)

Headlight Circuit Relay in Relay Box (see Relay Circuit Inspection in the Electrical System chapter)

Headlight Relay (High) (see Headlight Relay Inspection in the Electrical System chapter)

Harness (see Wiring Inspection in the Electrical System chapter)

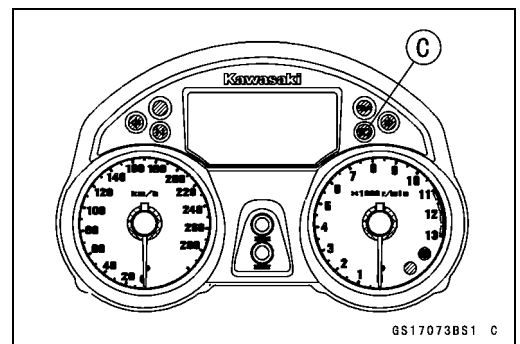
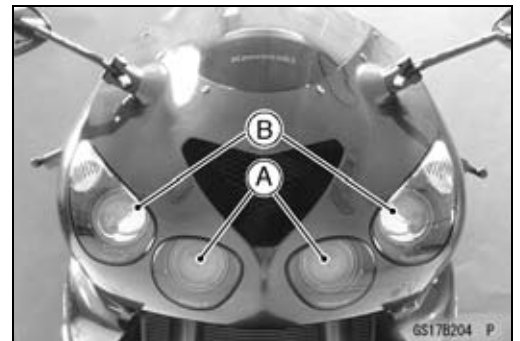

- Turn off the engine stop switch.
- The low beam and high beam headlights should stay going on.
- ★ If the headlights and high beam indicator light (LED) does go off, inspect or replace the following item.

Headlight Circuit Relay in Relay Box (see Relay Circuit Inspection in the Electrical System chapter)

- Turn off the ignition switch.
- The headlights and high beam indicator light (LED) should go off.

2-44 PERIODIC MAINTENANCE

Maintenance Procedure

Headlight Aiming Inspection

- Inspect the headlight beam for aiming.
- ★ If the headlight beam points to one side rather than straight ahead, adjust the horizontal beam.

Headlight Beam Horizontal Adjustment

- Turn the horizontal adjuster [A] in both headlights in or out until the beam points straight ahead.
- ★ If the headlight beam points too low or high, adjust the vertical beam.

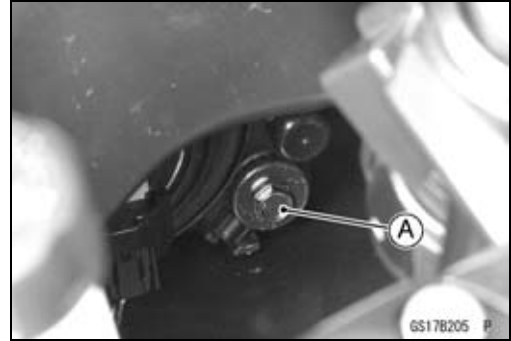

Headlight Beam Vertical Adjustment

- Turn the vertical adjuster [A] in both headlights in or out to adjust the headlight vertically.

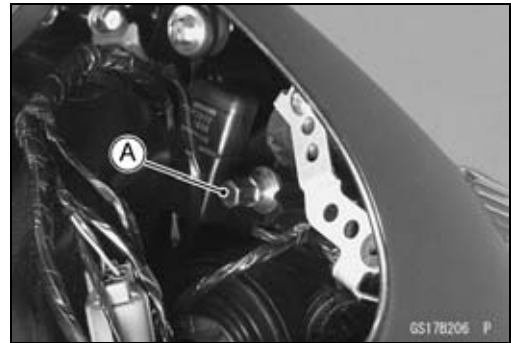

NOTE

- ON high beam, the brightest points should be slightly below horizontal with the motorcycle on its wheels and the rider seated. Adjust the headlight to the proper angle according to local regulations.
- For US model, the proper angle is 0.4 degrees below horizontal. This is 50 mm (2 in.) drop at 7.6 m (25 ft) measured from the center of the headlight with the motorcycle on its wheels and the rider seated.

50 mm (2 in.) [A]

Center of Brightest Spot [B]

7.6 m (25 ft) [C]

Low Beam [D]

Height of Headlight Center [E]

High Beam [F]

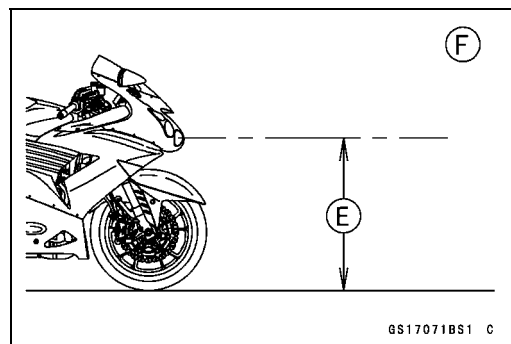
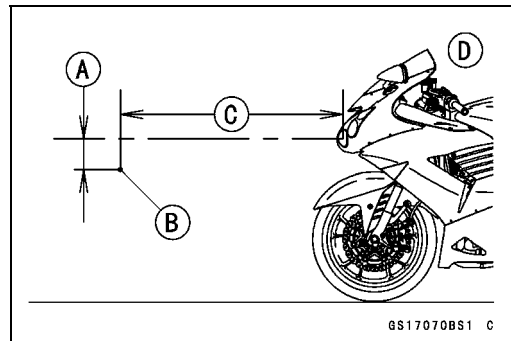

Maintenance Procedure

Sidestand Switch Operation Inspection

- Inspect the sidestand switch [A] operation accordance to table the below.

Sidestand Switch Operation

Sidestand	Gear Position	Clutch Lever	Engine Start	Engine Run
Up	Neutral	Released	Starts	Continue running
Up	Neutral	Pulled in	Starts	Continue running
Up	In Gear	Released	Doesn't start	Continue running
Up	In Gear	Pulled in	Starts	Continue running
Down	Neutral	Released	Starts	Continue running
Down	Neutral	Pulled in	Starts	Continue running
Down	In Gear	Released	Doesn't start	Stops
Down	In Gear	Pulled in	Doesn't start	Stops

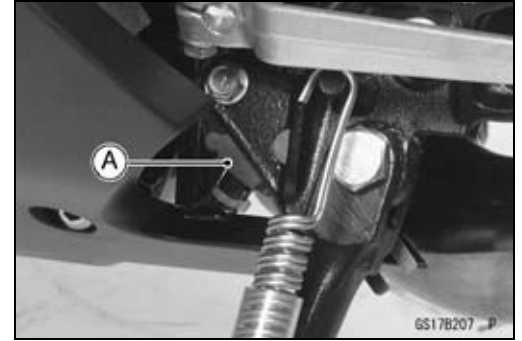

- ★ If the sidestand switch operation does not work, inspect or replace the following item.

Battery (see Charging Condition Inspection in the Electrical System chapter)

Main Fuse 30 A (see Fuse Inspection in the Electrical System chapter)

ECU Fuse 30 A (see Fuse Inspection in the Electrical System chapter)

Ignition Fuse 10 A (see Fuse Inspection in the Electrical System chapter)

Ignition Switch (see Switch Inspection in the Electrical System chapter)

Sidestand Switch (see Switch Inspection in the Electrical System chapter)

Starter Lockout Switch (see Switch Inspection in the Electrical System chapter)

Engine Stop Switch (see Switch Inspection in the Electrical System chapter)

Starter Button (see Switch Inspection in the Electrical System chapter)

Gear Position Switch (see Gear Position Switch Inspection in the Electrical System chapter)

Starter Relay (see Starter Relay Inspection in the Electrical System chapter)

Relay Box (see Relay Circuit Inspection in the Electrical System chapter)

Starter Circuit Relay (see Relay Circuit Inspection in the Electrical System chapter)

Harness (see Wiring Inspection in the Electrical System chapter)

- ★ If the all parts are in good condition, replace the ECU.

2-46 PERIODIC MAINTENANCE

Maintenance Procedure

Engine Stop Switch Operation Inspection

First Step

- Turn on the ignition switch.
- Set the neutral position.
- Turn the engine stop switch to stop position [A].
- Push the starter button.
- The engine does not start.
- ★ If the engine starts, inspect or replace the following item.
Engine Stop Switch (see Switch Inspection in the Electrical System chapter)



Second Step

- Turn on the ignition switch.
- Set the neutral position.
- Turn the engine stop switch to run position [A].
- Push the starter button and run the engine.
- Turn the engine stop switch to stop position.
- Immediately the engine should be stop.
- ★ If the engine does not stop, inspect or replace the following item.
Engine Stop Switch (see Switch Inspection in the Electrical System chapter)



Others

Chassis Parts Lubrication

- Before lubricating each part, clean off any rusty spots with rust remover and wipe off any grease, oil, dirt, or grime.
- Lubricate the points listed below with indicated lubricant.

NOTE

○Whenever the vehicle has been operated under wet or rainy conditions, or especially after using a high-pressure water spray, perform the general lubrication.

Pivots: Lubricate with Grease.

Brake Lever
Brake Pedal
Clutch Lever
Center Stand (Equipped Models)
Rear Brake Joint Pin
Sidestand

Points: Lubricate with Grease.

Throttle Inner Cable Upper and Lower Ends [A]

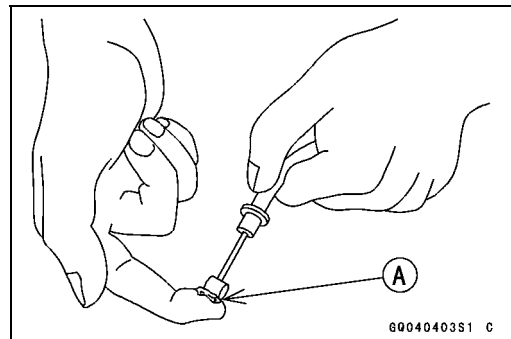

Maintenance Procedure

Cables: Lubricate with Rust Inhibitor.

Throttle Cables

- Lubricate the cables by seeping the oil between the cable and housing.
- The cable may be lubricated by using a commercially available pressure cable lubricator with an aerosol cable lubricant.

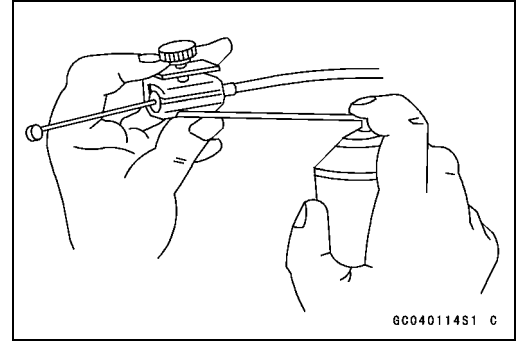

6C040114S1 C

- With the cable disconnected at both ends, the inner cable should move freely [A] within the cable housing.
- ★ If cable movement is not free after lubricating, if the cable is frayed [B], or if the cable housing is kinked [C], replace the cable.

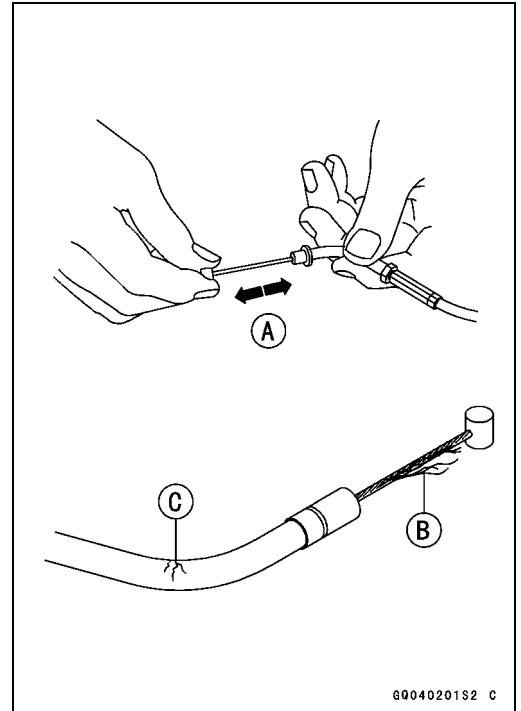

6Q040201S2 C

Bolts, Nuts and Fasteners Tightness Inspection

- Check the tightness of the bolts and nuts listed here. Also, check to see that each cotter pin is in place and in good condition.

NOTE

○ For the engine fasteners, check the tightness of them when the engine is cold (at room temperature).

- ★ If there are loose fasteners, retorque them to the specified torque following the specified tightening sequence. Refer to the appropriate chapter for torque specifications. If torque specifications are not in the appropriate chapter, see the Standard Torque Table. For each fastener, first loosen it by 1/2 turn, then tighten it.
- ★ If cotter pins are damaged, replace them with new ones.

2-48 PERIODIC MAINTENANCE

Maintenance Procedure

Bolt, Nut and Fastener to be checked

Engine:

- Clutch Lever Pivot Bolt Locknut
- Engine Mounting Bolts
- Muffler Clamp Bolts
- Exhaust Pipe Manifold Holder Nuts
- Muffler Body Mounting Bolts

Wheels:

- Front Axle Clamp Bolts
- Front Axle Nut
- Rear Axle Nut
- Rear Axle Nut Cotter Pin

Brakes:

- Brake Lever Pivot Nut
- Brake Pedal Bolt
- Brake Rod Joint Cotter Pin
- Caliper Mounting Bolts
- Front Master Cylinder Clamp Bolts
- Rear Master Cylinder Mounting Bolts

Suspension:

- Front Fork Clamp Bolts
- Rear Shock Absorber Mounting Nuts
- Swingarm Pivot Shaft Nut
- Uni-Trak Link Nuts

Steering:

- Handlebar Holder Bolts
- Steering Stem Head Nut

Others:

- Center Stand (Equipped Models)
- Footpeg Bracket Bolts
- Sidestand Bolt

Replacement Parts

Air Cleaner Element Replacement

NOTE

- *In dusty areas, the element should be replaced more frequently than the recommended interval.*
- *After riding through rain or on muddy roads, the element should be replaced immediately.*

WARNING

If dirt or dust is allowed to pass through into the throttle assembly, the throttle may become stuck, possibly causing an accident.

CAUTION

If dirt gets through into the engine, excessive engine wear and possibly engine damage will occur.

Maintenance Procedure

- Remove:
 - Fuel Tank Cover (see Fuel Tank Removal in the Fuel System (DFI) chapter)
 - Air Cleaner Element Cover Bolts [A]
 - Air Cleaner Element Cover [B]

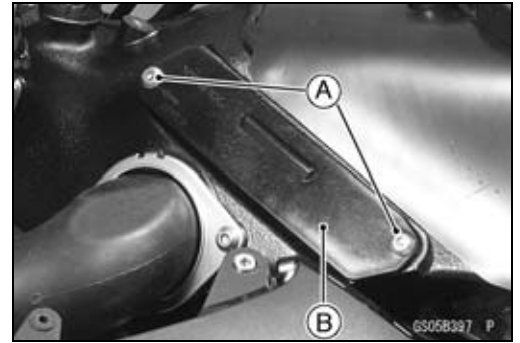

- Discard the air cleaner element [A].

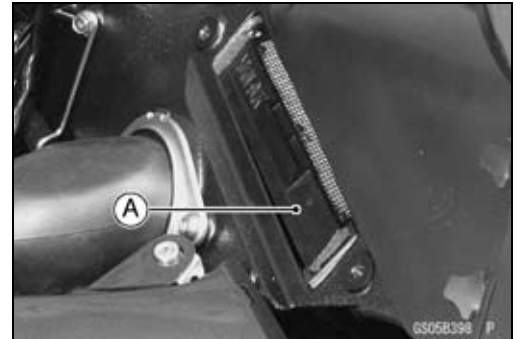

- Install a new element [A] so that screen side [B] faces upward.

CAUTION
<p>Use only the recommended air cleaner element (Kawasaki part number 11013-0014). Using another air cleaner element will wear the engine prematurely or lower the engine performance.</p>

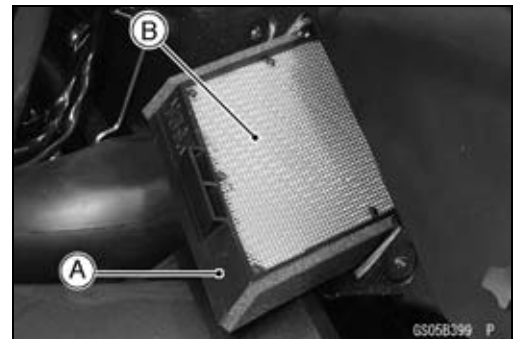

- Install the air cleaner element cover [A] so that arrow mark [B] faces forward.
- Tighten:
 - Torque - Air Cleaner Element Cover Bolts: 6.9 N·m (0.70 kgf·m, 61 in·lb)**



Fuel Hose Replacement

- Pull out the throttle body assy [A] from the holder (see Throttle Body Assy Removal in the Fuel System (DFI) chapter).
- Be sure to place a piece of cloth [B] around the fuel hose joint.
- Push the joint lock claws [C].

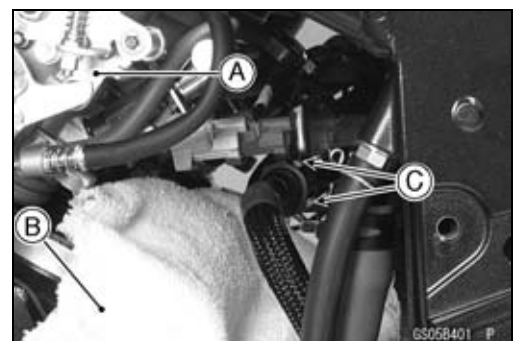

2-50 PERIODIC MAINTENANCE

Maintenance Procedure

- Pull the joint lock [A] as shown.
- Pull the fuel hose joint [B] out of the delivery pipe.
- Remove the throttle body assy (see Throttle Body Assy Removal in the Fuel System (DFI) chapter).
- Pull out the fuel hose to forward [C].

⚠ WARNING

Be prepared for fuel spillage; any spilled fuel must be completely wiped up immediately. When the fuel hose is disconnected, fuel spills out from the hose and the pipe. Cover the hose connection with a clean shop towel to prevent fuel spillage.

- Install the new fuel hose so that the white mark [A] side faces throttle body assy.
- Run the fuel hose correctly (see Cable, Wire, and Hose Routing section in the Appendix chapter).
- Pull [B] the joint lock [C] fully as shown.

- Insert the fuel hose joint [A] straight onto the delivery pipe until the hose joint clicks.
- Push [B] the joint lock [C] until the hose joint clicks.

- Push and pull the fuel hose joint [A] back and forth more than two times and make sure it is locked and doesn't come off.

⚠ WARNING

Make sure the fuel hose joint is installed correctly on the delivery pipe or the fuel could leak.

- ★ If it comes off, reinstall the hose joint.
- Install the throttle body assy (see Throttle Body Assy Installation in the Fuel System (DFI) chapter).
- Start the engine and check the fuel hose for leaks.

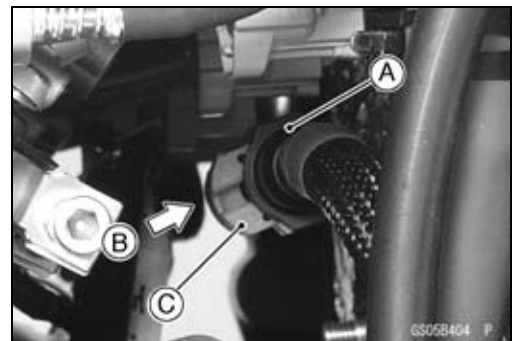
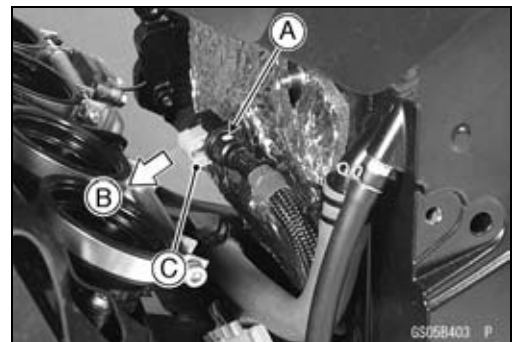
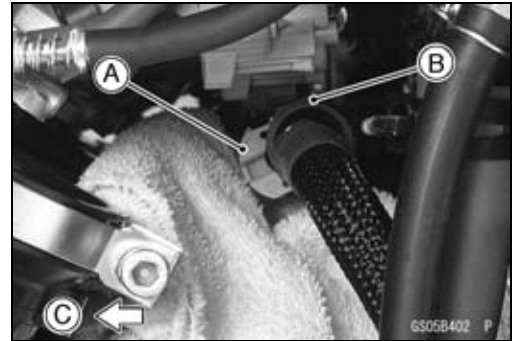

Maintenance Procedure

Coolant Change

⚠ WARNING

To avoid burns, do not remove the radiator cap or try to change the coolant when the engine is still hot. Wait until it cools down. Coolant on tires will make them slippery and can cause an accident and injury. Immediately wipe up or wash away any coolant that spills on the frame, engine, or other painted parts. Since coolant is harmful to the human body, do not use for drinking.

- Remove:
 - Right Middle Fairing (see Middle Fairing Removal in the Frame chapter)
 - Radiator Cap [A]
- Remove the radiator cap in two steps. First turn the cap counterclockwise to the first stop. Then push and turn it further in the same direction and remove the cap.



- Remove:
 - Left Lower Fairing (see Lower Fairing Removal in the Frame chapter)
 - Left Middle Fairing (see Frame chapter)
- Place a containers under the drain plug [A] at the bottom of the water pump cover.
- Drain the coolant from the radiator and engine by removing the drain plug.



- Remove:
 - Hoses [A]
 - Mounting Bolts [B]
 - Coolant Reserve Tank [C]
- Remove the cap [D] and pour the coolant into a container.

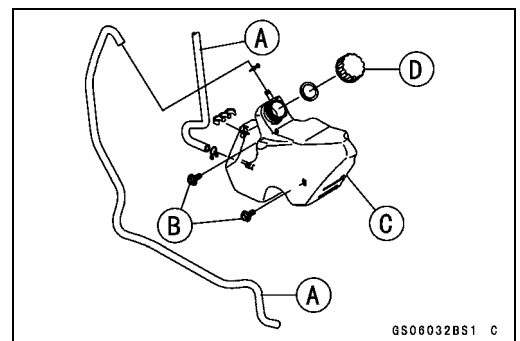

- Install the reserve tank, and reconnect the reserve tank hose and overflow hose correctly (see Cable, Wire, and Hose Routing in the Appendix chapter).
- Tighten the drain plug with the washer.
- Replace the drain plug gasket with a new one.

Torque - Coolant Drain Plug: 12 N·m (1.2 kgf·m, 106 in·lb)

2-52 PERIODIC MAINTENANCE

Maintenance Procedure

- Fill the radiator up to the radiator filler neck [A] with coolant, and install the radiator cap.

NOTE

○ Pour in the coolant slowly so that it can expel the air from the engine and radiator.

- Fill the reserve tank up to the full level line with coolant, and install the cap.

CAUTION

Soft or distilled water must be used with the antifreeze (see below for antifreeze) in the cooling system.

If hard water is used in the system, it causes scales accumulation in the water passages, and considerably reduces the efficiency of the cooling system.

Water and Coolant Mixture Ratio (Recommended)

Soft Water:	50%
Coolant:	50%
Freezing Point:	-35°C (-31°F)
Total Amount:	3.4 L (3.6 US qt)

NOTE

○ Choose a suitable mixture ratio by referring to the coolant manufacturer's directions.

- Bleed the air from the cooling system as follows.
 - Start the engine with the radiator cap removed and run it until no more air bubbles [A] can be seen in the coolant.
 - Tap the radiator hoses to force any air bubbles caught inside.
 - Stop the engine and add coolant up to the radiator filler neck.
- Install the radiator cap.
- Start the engine, warm it up thoroughly until the radiator fan turns on and then stop the engine.
- Check the coolant level in the reserve tank after the engine cools down.
- ★ If the coolant level is lower than the low level line, add coolant to the full level line.

CAUTION

Do not add more coolant above the full level line.

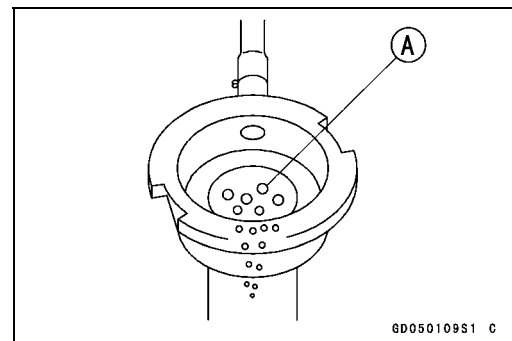
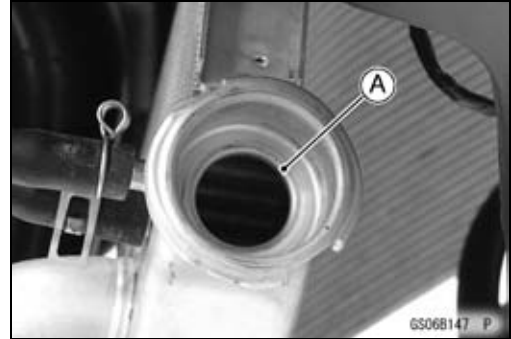

Maintenance Procedure

Radiator Hose and O-ring Replacement

- Drain the coolant (see Coolant Change).
- Remove:
 - Lower Fairings (see Lower Fairing Removal in the Frame chapter)
 - Middle Fairings (see Middle Fairing Removal in the Frame chapter)
 - Throttle Body Assy (see Throttle Body Assy Removal in the Fuel System (DFI) chapter)
 - Thermostat Housing [A]
 - Fitting [B]
 - Hoses [C]
 - O-rings [D]
- Apply grease to the new O-rings and install them.
- Instal the new hoses and tighten the clamps securely.
- Fill the coolant (see Coolant Change in the Periodic Maintenance chapter).
- Check the cooling system for leaks.

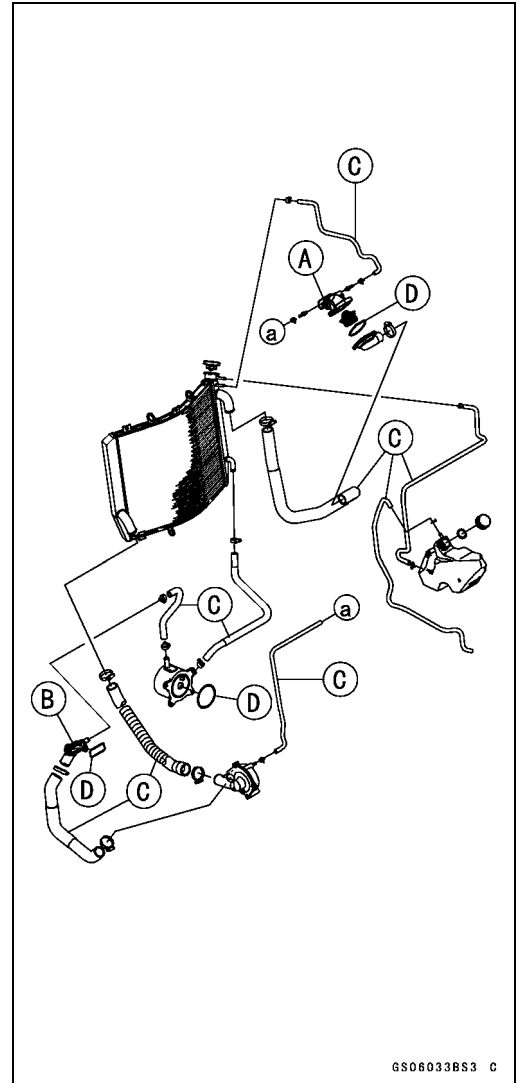

Engine Oil Change

- Situate the motorcycle so that it is vertical after warming up the engine.
- Remove the engine oil drain bolt [A] to drain the oil.
- The oil in the oil filter can be drained by removing the filter (see Oil Filter Replacement).
- ★Replace the drain bolt gasket [B] with a new one.
- Tighten the drain bolt.
- Torque - Engine Oil Drain Bolt: 30 N·m (3.0 kgf·m, 22 ft·lb)**
- Pour in the specified type and amount of oil.

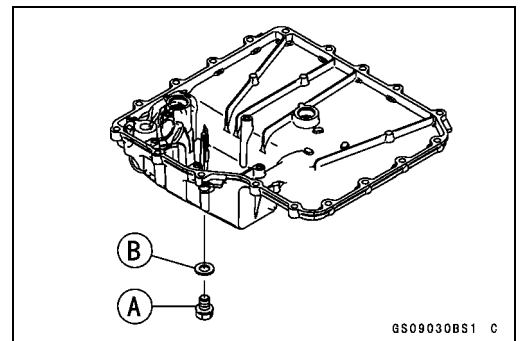

2-54 PERIODIC MAINTENANCE

Maintenance Procedure

Recommended Engine Oil

- Type: API SE, SF or SG
API SH, SJ or SL with JASO MA
- Viscosity: SAE 10W-40
- Capacity: 3.7 L (3.9 US qt) (when filter is not removed)
4.1 L (4.3 US qt) (when filter is removed)
4.5 L (4.8 US qt) (when engine is completely dry)

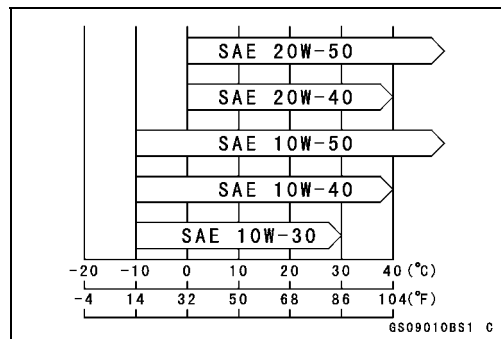

NOTE

- Although 10W-40 engine oil is the recommended oil for most conditions, the oil viscosity may need to be changed to accommodate atmospheric conditions in your riding area.

Oil Filter Replacement

- Drain the engine oil (see Engine Oil Change).
- Remove:
 - Lower Fairing (see Frame chapter)
- Remove the oil filter [A] with the oil filter wrench [B].

Special Tool - Oil Filter Wrench: 57001-1249

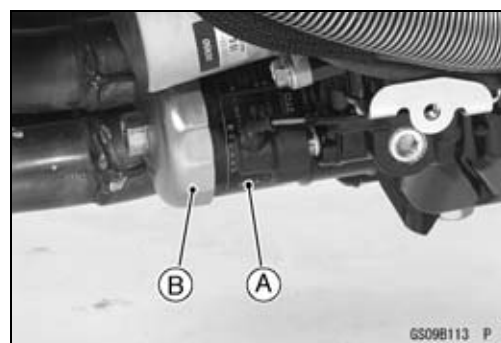

- Replace the filter with a new one.
- Apply engine oil to the gasket [A] before installation.
- Tighten the filter with the oil filter wrench.

Torque - Oil Filter: 31 N·m (3.2 kgf·m, 23 ft·lb)

NOTE

- Hand tightening of the oil filter can not be allowed since it does not reach to this tightening torque.
- Pour in the specified type and amount of oil (see Engine Oil Change).

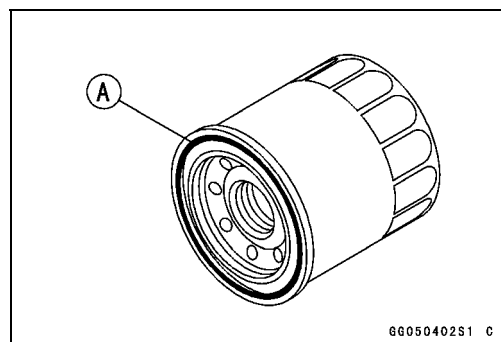

Maintenance Procedure

Brake Hose and Pipe Replacement

CAUTION

Brake fluid quickly ruins painted plastic surfaces; any spilled fluid should be completely washed away immediately.

- Remove the brake hose banjo bolts [A].
- When removing the brake hose, take care not to spill the brake fluid on the painted or plastic parts.
- When removing the brake hoses [B], temporarily secure the end of the brake hose to some high place to keep fluid loss to a minimum.
- Immediately wash away any brake fluid that spills.

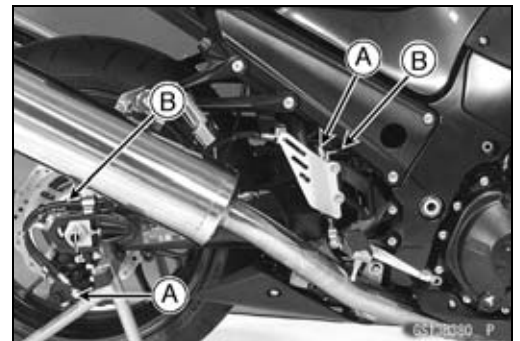
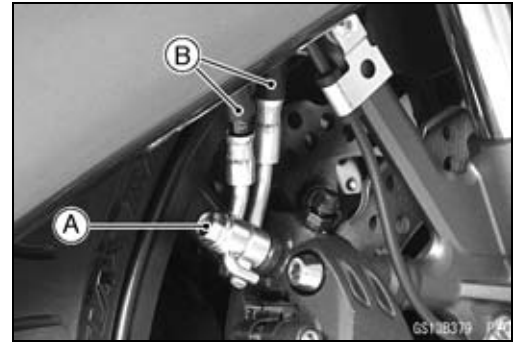

2-56 PERIODIC MAINTENANCE

Maintenance Procedure

- For ABS equipped models; note the following.
- Remove:
 - Fuel Tank (see Fuel Tank Removal in the Fuel System (DFI) chapter)
 - Battery (see Battery Removal in the Electrical System chapter)
 - Upper Fairing (see Upper Fairing Removal in the Frame chapter)
 - Brake Pipe Joint Nuts [A]
 - Bolts [B]
 - Bracket [C]
- There are washers on each side of the brake hose fitting. Replace them with new ones when installing.
- Tighten:
 - Torque - Brake Hose Banjo Bolts: 25 N·m (2.5 kgf·m, 18 ft·lb)**
 - Brake Pipe Joint Nuts: 18 N·m (1.8 kgf·m, 13 ft·lb)**
(ZX1400B Models)
- When installing the hoses, avoid sharp bending, kinking, flattening or twisting, and route the hoses according to Cable, Wire, and Hose Routing section in the Appendix chapter.
- Fill the brake line after installing the brake hose (see Brake Fluid Change).

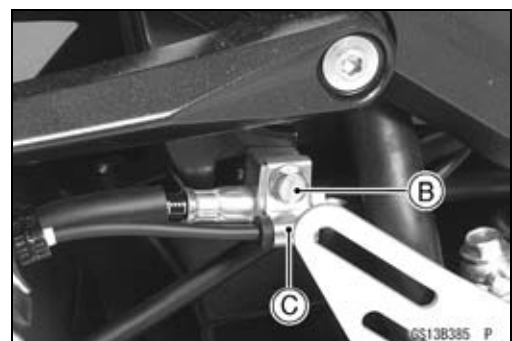
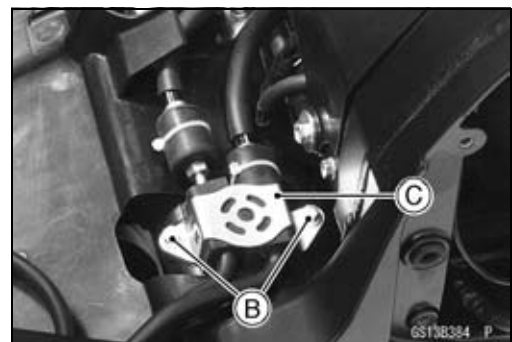
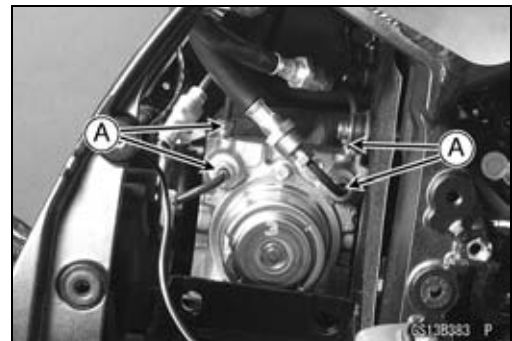
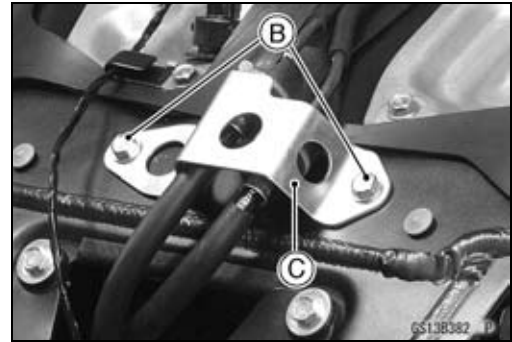
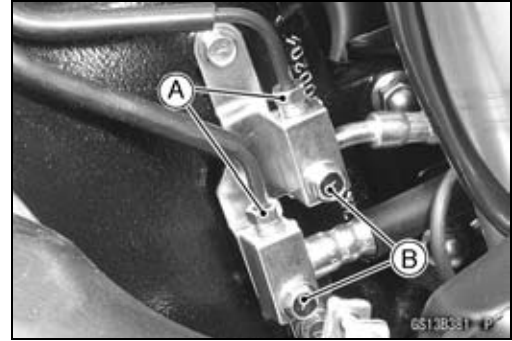

Maintenance Procedure

Brake Fluid Change

NOTE

○The procedure to change the front brake fluid is as follows. Changing the rear brake fluid is the same as for the front brake.

- Level the brake fluid reservoir.
- Remove the reservoir cap and diaphragm.
- Remove the rubber cap from the bleed valve [A] on the caliper.
- Attach a clear plastic hose [B] to the bleed valve, and run the other end of the hose into a container.
- Fill the reservoir with fresh specified brake fluid.

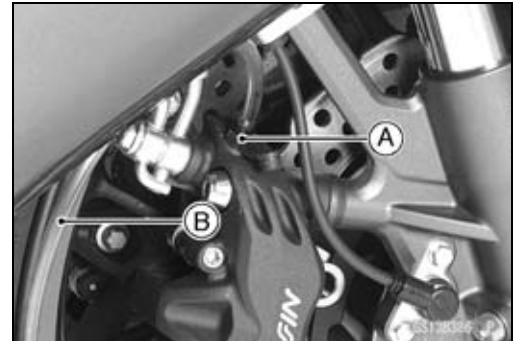

- Change the brake fluid.
- Repeat this operation until fresh brake fluid comes out from the plastic hose or the color of the fluid changes.

 1. Open the bleed valve [A].
 2. Apply the brake and hold it [B].
 3. Close the bleed valve [C].
 4. Release the brake [D].

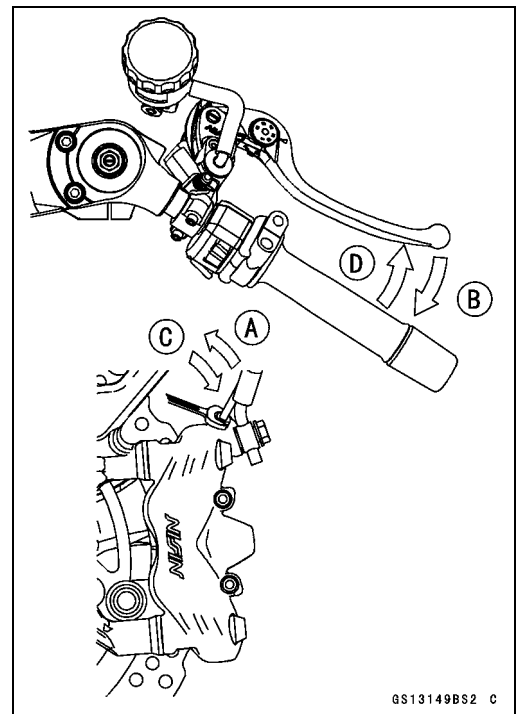

NOTE

○The fluid level must be checked often during the changing operation and replenished with fresh brake fluid. If the fluid in the reservoir runs out any time during the changing operation, the brakes will need to be bled since air will have entered the brake line.

○Front Brake: Repeat the above steps for the other caliper.

- Remove the clear plastic hose.
- Install the diaphragm and reservoir cap.

- Follow the procedure below to install the front brake fluid reservoir cap correctly.

○First, tighten the front brake fluid reservoir cap [B] clockwise [C] by hand until slight resistance is felt indicating that the cap is seated on the reservoir body, then tighten the cap an additional 1/6 turn [D] while holding the brake fluid reservoir body [A].

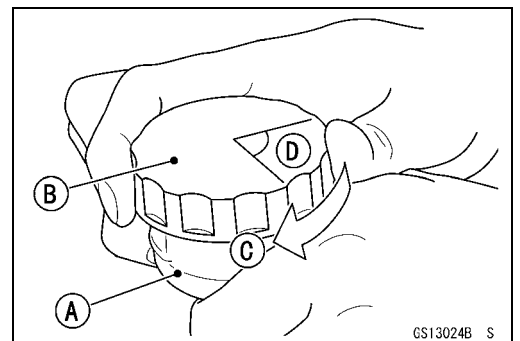

2-58 PERIODIC MAINTENANCE

Maintenance Procedure

- Tighten:
Torque - Front Brake Reservoir Cap Stopper Screw: 1.2 N·m (0.12 kgf·m, 11 in·lb)
- Tighten the bleed valve, and install the rubber cap.
Torque - Bleed Valve: 7.8 N·m (0.80 kgf·m, 69 in·lb)
- After changing the fluid, check the brake for good braking power, no brake drag, and no fluid leakage.
- ★ If necessary, bleed the air from the lines.

Master Cylinder Rubber Parts Replacement

Front Master Cylinder Disassembly

- Remove the front master cylinder (see Front Master Cylinder Removal in the Brakes chapter).
- Remove the seal cover [A], circlip [B], connector [C] and O-ring [D].

Special Tool - Inside Circlip Pliers: 57001-143

- Unscrew the locknut [E] and pivot bolt [F], and remove the brake lever.
- Remove the circlip [G].
- Pull out the piston assy [H].
- Replace:
 - Seal Cover [A]
 - Circlip [B]
 - O-ring [D]
 - Circlip [G]
 - Piston Assy [H]
 - Diaphragm [I]

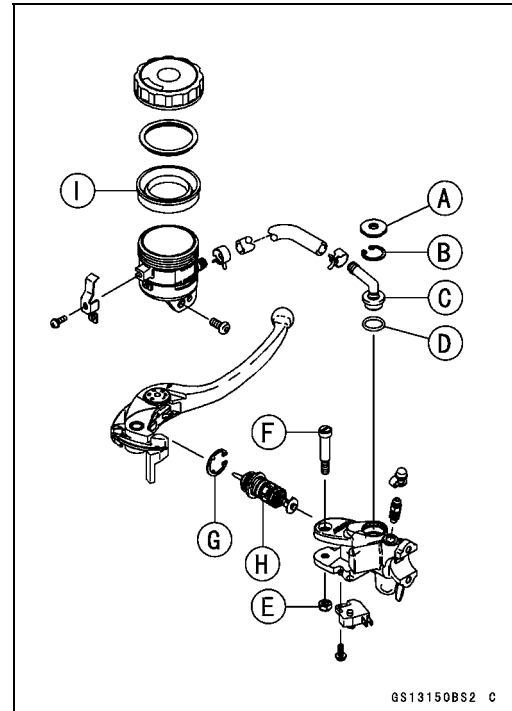

GS13150BS2 C

Rear Master Cylinder Disassembly

- Remove the rear master cylinder (see Rear Master Cylinder Removal in the Brakes chapter).
- Remove the circlip [A], connector [B] and O-ring [C].

Special Tool - Inside Circlip Pliers: 57001-143

- Slide the dust cover [D] out of place, and remove the circlip [E].
- Pull out the push rod assy [F].
- Take off the piston assy [G] and return spring [H].

CAUTION

Do not remove the secondary cup from the piston since removal will damage it.

- Replace:
 - Circlip [A]
 - O-ring [C]
 - Circlip [E]
 - Push Rod Assy [F]
 - Piston Assy [G]
 - Diaphragm [I]

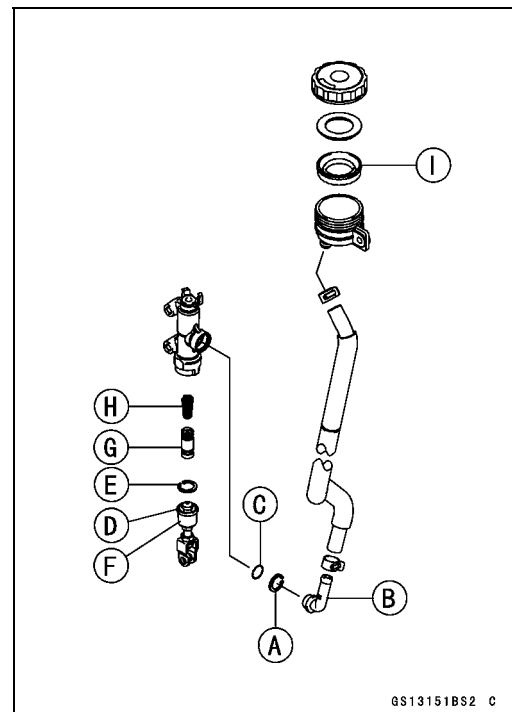

GS13151BS2 C

Maintenance Procedure

Master Cylinder Assembly

- Before assembly, clean all parts including the master cylinder with brake fluid or alcohol.

CAUTION

Except for the disc pads and disc, use only disc brake fluid, isopropyl alcohol, or ethyl alcohol for cleaning brake parts. Do not use any other fluid for cleaning these parts. Gasoline, engine oil, or any other petroleum distillate will cause deterioration of the rubber parts. Oil spilled on any part will be difficult to wash off completely, and will eventually deteriorate the rubber used in the disc brake.

- Apply brake fluid to the new parts and to the inner wall of the cylinder.
- Take care not to scratch the piston or the inner wall of the cylinder.
- Apply silicone grease to the brake lever pivot bolt.
- Tighten the brake lever pivot bolt and the locknut.

Torque - Brake Lever Pivot Bolt: 1.0 N·m (0.10 kgf·m, 9 in·lb)

Brake Lever Pivot Bolt Locknut: 5.9 N·m (0.60 kgf·m, 52 in·lb)

Caliper Rubber Parts Replacement

Front Caliper Disassembly

- Loosen the front caliper pad pins [A] and banjo bolt [B] and tighten them loosely.
- Remove:
 - Front Caliper [C] (see Front Caliper Removal in the Brakes chapter)
 - Brake Pads (see Front Brake Pad Removal in the brakes chapter)
 - Front Caliper Assembly Bolts
 - O-ring



- Using compressed air, remove the pistons. One way to remove the pistons is as follows.
 - Install a rubber gasket [A] and a wooden board [B] more than 10 mm (0.4 in.) thick on the caliper half, and fasten them together with a suitable bolt and nut as shown. Leave one of the oil passages [C] open.
 - Lightly apply compressed air [D] to the oil passage until the pistons hit the rubber gasket. Block the hose joint opening [E] during this operation if the caliper half has the opening.
 - Bolt [F] and Nut
 - Push down [G].

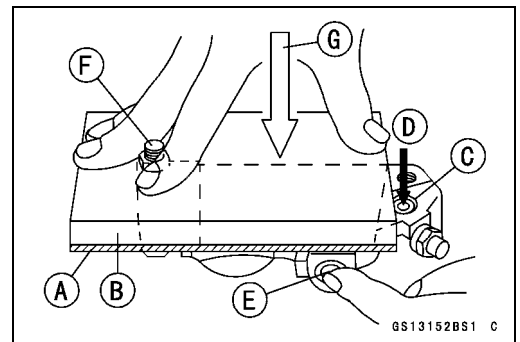

2-60 PERIODIC MAINTENANCE

Maintenance Procedure

⚠ WARNING

To avoid serious injury, never place your fingers or palm in front of the piston. If you apply compressed air into the caliper, the piston may crush your hand or fingers.

- Pull out the pistons by hand.
- Remove the dust seals [A] and fluid seals [B].
- Remove the bleed valve [C] and rubber cap [D].
- Repeat the previous step to remove the pistons from the other side of the caliper body.

NOTE

- If compressed air is not available, do as follows for both calipers coincidentally, with the brake hose connected to the caliper.
- Prepare a container for brake fluid, and perform the work above it.
- Remove the pad springs and pads (see *Front Brake Pad Removal in the Brakes chapter*).
- Pump the brake lever until the pistons come out of the cylinders, and then disassemble the caliper.

Front Caliper Assembly

- Clean the caliper parts except for the pads.

CAUTION

For cleaning the parts, use only disc brake fluid, isopropyl alcohol, or ethyl alcohol.

- Install the bleed valve and rubber cap.
Torque - Bleed Valve: 7.8 N·m (0.80 kgf·m, 69 in·lb)
- Replace the fluid seals [A] with new ones.
- Apply silicone grease to the fluid seals, and install them into the cylinders by hand.
- Replace the dust seals [B] with new ones if they are damaged.
- Apply silicone grease to the dust seals, and install them into the cylinders by hand.
- Replace the O-ring [A].
- Apply brake fluid to the outside of the pistons, and push them into each cylinder by hand.
- Be sure to install the O-ring.
- Apply a non-permanent locking agent to the threads of the front caliper assembly bolts, and tighten them.

Torque - Front Caliper Assembly Bolts: 27 N·m (2.8 kgf·m, 20 ft·lb)

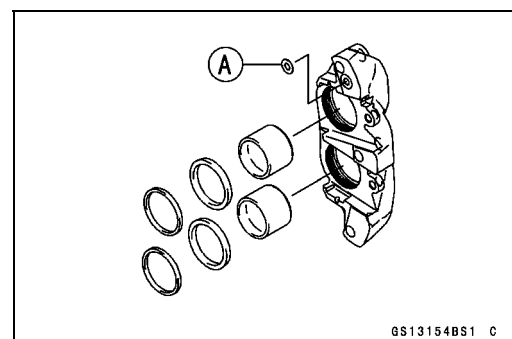
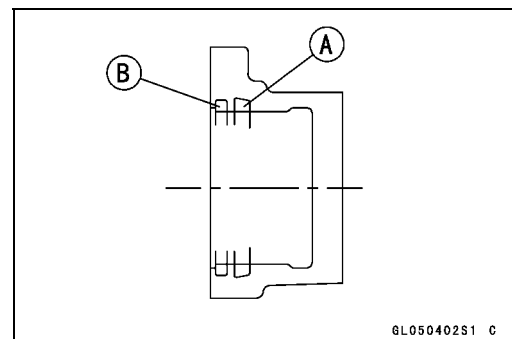
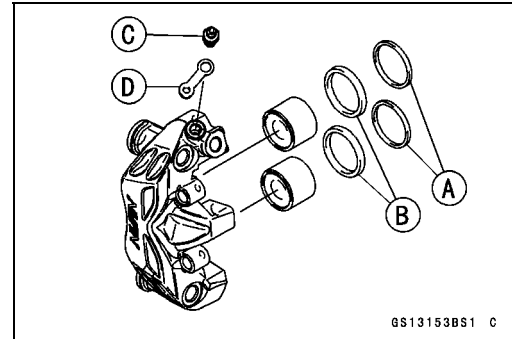

Maintenance Procedure

- Install the pads (see Front Brake Pad Installation in the Brakes chapter).
- Wipe up any spilled brake fluid on the caliper with wet cloth.

Rear Caliper Disassembly

- Loosen the rear caliper pad pin [A] and banjo bolt [B], and tighten them loosely.
- Remove:
 - Rear Caliper [C] (see Rear Caliper Removal in the Brakes chapter)
 - Brake Pads (see Rear Brake Pad Removal in the Brakes chapter)
 - Rear Caliper Assembly Bolts
 - O-ring

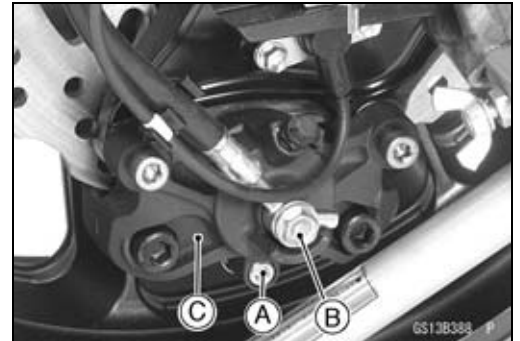

- Remove the left side piston as follows.
- Removal of the left side piston is the same as for the front caliper.
 - Left Side Caliper [A]
 - Rubber Gasket [B]
 - Wooden Board [C]
 - Bolt [D] and Nut
 - Apply compressed air [E]

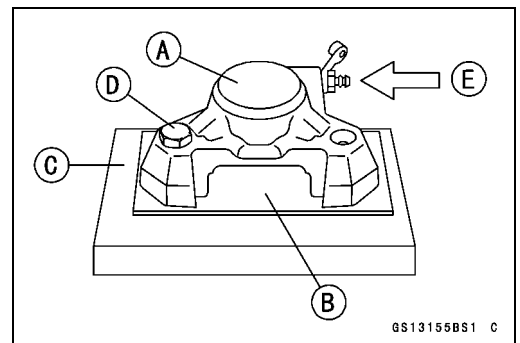

⚠ WARNING

To avoid serious injury, never place your fingers or palm in rear of the piston. If you apply compressed air into the caliper, the piston may crush your hand or fingers.

- Remove the right side piston as follows.
- Using the rear caliper assembly bolt [A], remove the piston [B] as shown in the figure.

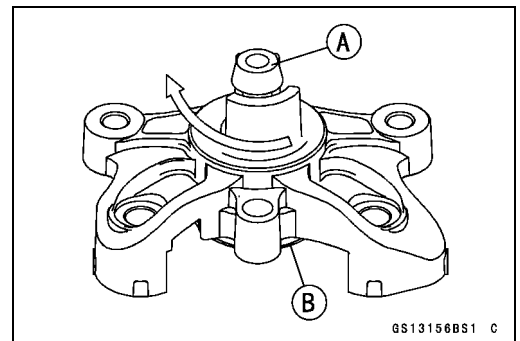

2-62 PERIODIC MAINTENANCE

Maintenance Procedure

- Remove the dust seals [A] and fluid seals [B].
- Remove the bleed valves [C] and rubber caps [D].

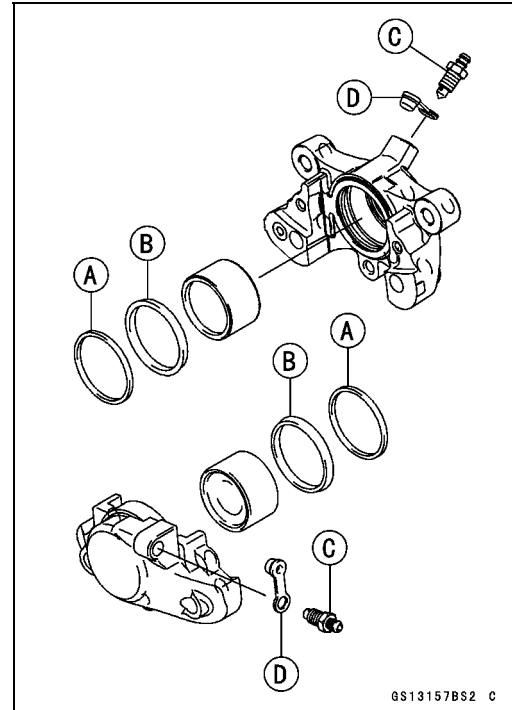

NOTE

- If compressed air is not available, do as follows with the brake hose connected to the caliper.
- Prepare a container for brake fluid, and perform the work above it.
- Remove the pads and pad spring (see *Rear Brake Pad Removal* in the *Brakes* chapter).
- Pump the brake pedal to remove the caliper piston.

Rear Caliper Assembly

- Clean the caliper parts except for the pads.

CAUTION

For cleaning the parts, use only disc brake fluid, isopropyl alcohol, or ethyl alcohol.

- Install the bleed valves and rubber caps.
Torque - Bleed Valves: 7.8 N·m (0.80 kgf·m, 69 in·lb)
- Apply brake fluid to the cylinder bores.
- Replace the fluid seals [A] with new ones.
- Apply silicone grease to the fluid seals, and install them into each cylinder by hand.
- Replace the dust seals [B] with new ones.

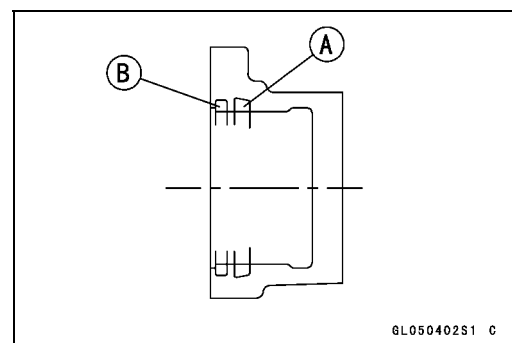

Maintenance Procedure

- Replace the O-ring [A].
- Apply brake fluid to the outside of the pistons, and push them into each cylinder by hand.
- Be sure to install the O-ring.
- Apply a non-permanent locking agent to the threads of the rear caliper assembly bolts, and tighten them.

Torque - Rear Caliper Assembly Bolts: 37 N·m (3.8 kgf·m, 27 ft·lb)

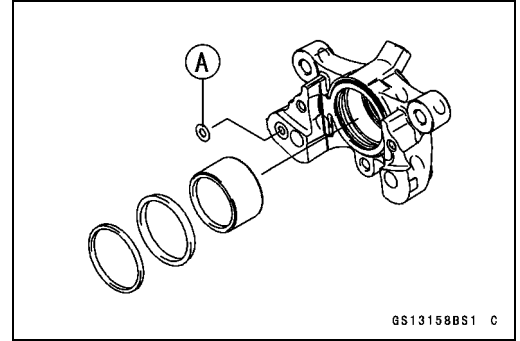

- Install the pads (see Rear Brake Pad Installation in the Brakes chapter).
- Wipe up any spilled brake fluid on the caliper with wet cloth.

Clutch Hose and Pipe Replacement

CAUTION
Clutch fluid quickly ruins painted plastic surfaces; any spilled fluid should be completely washed away immediately.

- When removing the clutch hose, take care not to spill the clutch fluid on the painted or plastic parts.
- When removing the clutch hose [A], temporarily secure the end of the clutch hose to some high place to keep fluid loss to a minimum.
- Immediately wash away any clutch fluid that spills.
- There are washers on each side of the clutch hose fittings. Replace them with new ones when installing.
- Tighten:

Torque - Clutch Hose Banjo Bolts: 25 N·m (2.5 kgf·m, 18 ft·lb)

- When installing the hoses [A], avoid sharp bending, kinking, flattening or twisting, and route the hoses according to Cable, Wire, and Hose Routing section in Appendix chapter.
- Fill the clutch line after installing the clutch hose (see Clutch Fluid Change).

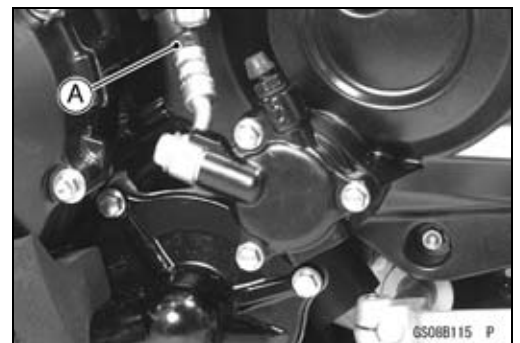
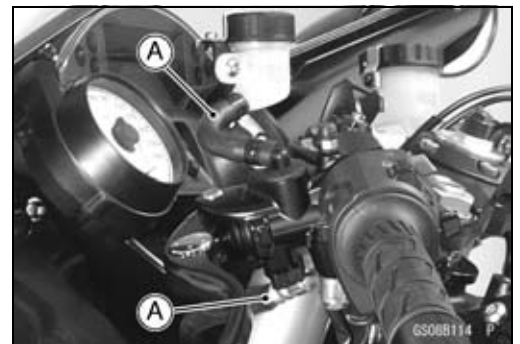

2-64 PERIODIC MAINTENANCE

Maintenance Procedure

Rubber Parts of Clutch Master Cylinder/Slave Cylinder Replacement

Clutch Master Cylinder Cup and Dust Seal Replacement

- Remove the clutch master cylinder (see Clutch Master Cylinder Removal in the Clutch chapter).
- Remove the seal cover [A], circlip [B], connector [C] and O-ring [D].

Special Tool - Inside Circlip Pliers: 57001-143

- Unscrew the locknut [E] and pivot bolt [F], and remove the clutch lever.
- Pull the circlip [G].
- Pull out the piston assy [H].
- Replace:
 - Seal Cover [A]
 - Circlip [B]
 - O-ring [D]
 - Circlip [G]
 - Piston Assy [H]
 - Diaphragm [I]

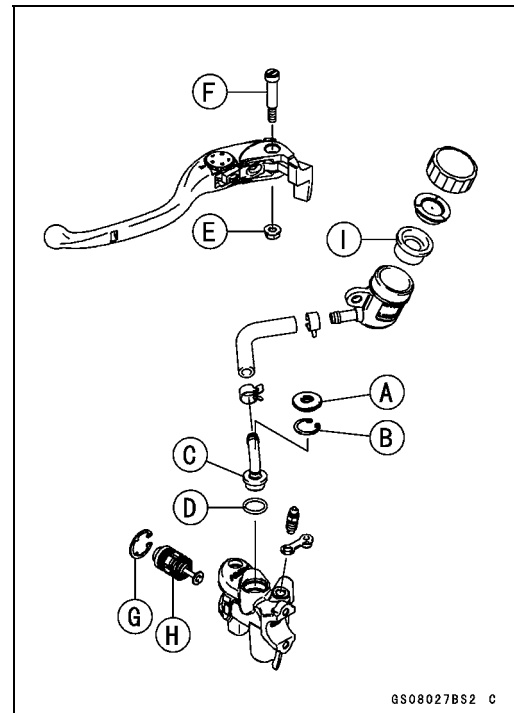

GS08027BS2 C

- Before assembly, clean all parts including the master cylinder with clutch fluid or alcohol.

CAUTION

Use only disc brake fluid, isopropyl alcohol or ethyl alcohol for cleaning parts. Do not use any other fluid for cleaning these parts. Gasoline, motor oil or any other petroleum distillate will cause deterioration of the rubber parts. Oil spilled on any part will be difficult to wash off completely, and will eventually deteriorate the rubber used in the cylinder.

- Apply clutch fluid to the parts removed and to the inner wall of the cylinder.
- Take care not to scratch the piston or the inner wall of the cylinder.

Torque - Clutch Lever Pivot Bolt: 1.0 N·m (0.10 kgf·m, 8.9 in·lb)

Clutch Lever Pivot Bolt Locknut: 5.9 N·m (0.60 kgf·m, 52 in·lb)

- Install the clutch master cylinder (see Clutch Master Cylinder Removal in the Clutch chapter).

Maintenance Procedure

Clutch Slave Cylinder Piston Seal Replacement

- Remove the left lower fairing (see Lower Fairing Removal in the Frame chapter).
- Remove the coolant reserve tank.
- Loosen the banjo bolt [A] at the clutch pipe lower end, and tighten it loosely.
- Unscrew the slave cylinder bolts [B] and detach the slave cylinder with the pipe installed from the engine.
- Pump the clutch lever until the piston comes out of the cylinder.
- Unscrew the banjo bolt and remove the slave cylinder [C].

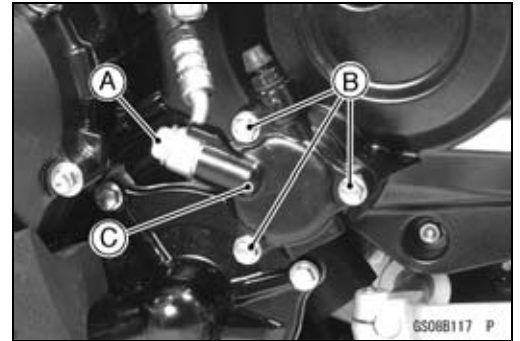

CAUTION

Immediately wash away any clutch fluid that spills. It may damage painted surfaces.

NOTE

○ If the clutch slave cylinder is removed and left alone, the piston will be pushed out by spring force.

- Remove the spring and piston seal.

CAUTION

Replace the piston seal with a new one if it was removed from the piston.

- Before assembly, apply clutch fluid to the outside of the piston and the piston seal.
- Install the piston seal as shown.
 - Cylinder [A]
 - Piston [B]
 - Piston Seal [C]
 - Spring [D]

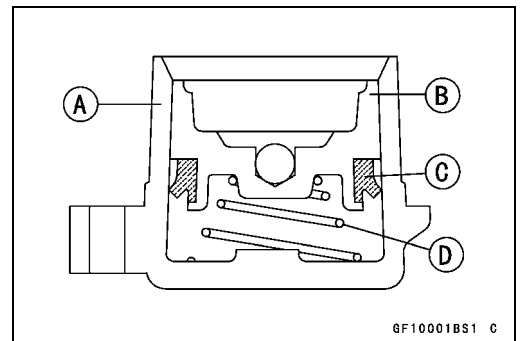

▲ WARNING

Motorcycle operation with insufficient, deteriorated or contaminated engine oil will cause accelerated wear and may result in engine or transmission seizure, accident, and injury.

2-66 PERIODIC MAINTENANCE

Maintenance Procedure

Clutch Fluid Change

- Level the clutch fluid reservoir and remove the reservoir cap.
- Remove the left lower fairing (see Frame chapter).
- Remove the rubber cap from the bleed valve on the clutch slave cylinder.
- Attach a clear plastic hose [A] to the bleed valve and run the other end of the hose into a container.
- Fill the reservoir with fresh fluid.
- Change the clutch fluid as follows.
 - Open [B] the bleed valve, using a wrench.
 - Pump the clutch lever and hold [C] it.
 - Close [D] the bleed valve.
 - Release [E] the clutch lever.
- Repeat this operation until fresh fluid comes out from the plastic hose or the color of the fluid changes.
- Check the fluid level in the reservoir often, replenishing it as necessary.

NOTE

○ If the fluid in the reservoir runs completely out any time during fluid changing, the bleeding operation must be done over again from the beginning since air will have entered the line.

⚠ WARNING

Do not mix two brands of fluid.

- After changing the fluid, check the clutch for good clutch power and no fluid leakage.
- ★ If necessary, bleed the air from the lines (see Clutch Line Bleeding in the Clutch chapter).
- Remove the clear plastic hose.
- Install the reservoir cap.
- Tighten the bleed valve, and install the rubber cap.

Torque - Clutch Slave Cylinder Bleed Valve: 7.8 N·m (0.80 kgf·m, 69 in·lb)

Spark Plug Replacement

- Remove:
 - Stick Coils (see Stick Coil Removal in the Electrical System chapter)
- Remove the spark plug using the 16 mm (0.63 in.) plug wrench [A] vertically.

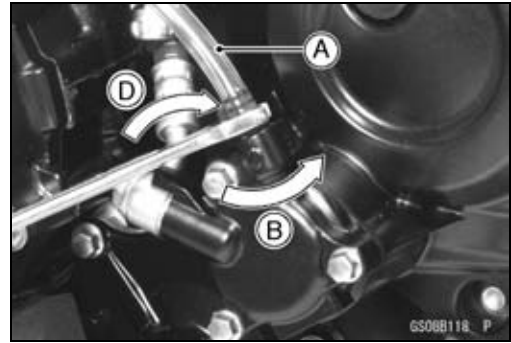

Maintenance Procedure

- Replace the spark plug with a new one.

Standard Spark Plug

Type: **NGK CR9EIA-9**

- Insert new spark plug in the plug hole, and finger-tighten it first.
- Using the plug wrench [A] vertically, tighten the plug.

CAUTION

The insulator of the spark plug may break if when the wrench is inclined during tightening.

Torque - Spark Plugs: 13 N·m (1.3 kgf·m, 115 in·lb)

- Install the stick coils securely.
- Be sure the stick coils are installed by pulling up it lightly.



Fuel System (DFI)

Table of Contents

Exploded View.....	3-4
DFI System.....	3-10
DFI Parts Location.....	3-16
Specifications	3-18
Special Tools and Sealant.....	3-20
DFI Servicing Precautions.....	3-22
DFI Servicing Precautions	3-22
Troubleshooting the DFI System.....	3-24
Outline	3-24
Inquiries to Rider.....	3-29
DFI System Troubleshooting Guide	3-32
Self-Diagnosis	3-37
Self-diagnosis Outline.....	3-37
Self-diagnosis Procedures.....	3-38
Service Code Reading	3-41
Service Code Erasing	3-41
Backups.....	3-43
Main Throttle Sensor (Service Code 11)	3-45
Main Throttle Sensor Removal/Adjustment	3-45
Input Voltage Inspection.....	3-45
Output Voltage Inspection.....	3-47
Resistance Inspection.....	3-50
Inlet Air Pressure Sensor (Service Code 12).....	3-51
Removal.....	3-51
Installation.....	3-51
Input Voltage Inspection.....	3-52
Output Voltage Inspection.....	3-53
Inlet Air Temperature Sensor (Service Code 13).....	3-57
Removal/Installation.....	3-57
Output Voltage Inspection.....	3-57
Sensor Resistance Inspection	3-58
Water Temperature Sensor (Service Code 14)	3-60
Removal/Installation.....	3-60
Output Voltage Inspection.....	3-60
Sensor Resistance Inspection	3-61
Atmospheric Pressure Sensor (Service Code 15).....	3-62
Removal.....	3-62
Installation.....	3-62
Input Voltage Inspection.....	3-62
Output Voltage Inspection.....	3-63
Crankshaft Sensor (Service Code 21).....	3-66
Crankshaft Sensor Removal/Installation.....	3-66
Crankshaft Sensor Inspection.....	3-66
Camshaft Position Sensor (Service Code 23).....	3-67
Camshaft Position Sensor Removal/Installation	3-67
Camshaft Position Sensor Inspection	3-67
Speed Sensor (Service Code 24).....	3-68
Speed Sensor Removal/Installation.....	3-68
Speed Sensor Inspection.....	3-68
Input Voltage Inspection.....	3-68

3-2 FUEL SYSTEM (DFI)

Output Voltage Inspection.....	3-69
Gear Position Switch (Service Code 25).....	3-71
Gear Position Switch Removal/Installation.....	3-71
Gear Position Switch Inspection.....	3-71
Input Voltage Inspection.....	3-71
Vehicle-down Sensor (Service Code 31).....	3-73
Removal.....	3-73
Installation.....	3-73
Inspection.....	3-74
Subthrottle Sensor (Service Code 32).....	3-76
Subthrottle Sensor Removal/Adjustment.....	3-76
Input Voltage Inspection.....	3-76
Output Voltage Inspection.....	3-78
Resistance Inspection.....	3-80
Immobilizer Amplifier (Service Code 35).....	3-81
Antenna Resistance Inspection.....	3-81
Amplifier Input Voltage Inspection.....	3-81
Blank Key Detection (Service Code 36).....	3-82
User Key Inspection.....	3-82
Fuel Pump Relay (Service Code 46).....	3-83
Fuel Pump Relay Removal.....	3-83
Fuel Pump Relay Inspection.....	3-83
Stick Coils #1, #2, #3, #4: (Service Code 51, 52, 53, 54).....	3-85
Removal/Installation.....	3-85
Input Voltage Inspection.....	3-85
Subthrottle Valve Actuator (Service Code 62).....	3-87
Subthrottle Valve Actuator Removal.....	3-87
Subthrottle Valve Actuator Inspection.....	3-87
Resistance Inspection.....	3-87
Input Voltage Inspection.....	3-88
ECU Main Relay (Service Code 75).....	3-90
ECU Main Relay Inspection.....	3-90
ECU.....	3-91
ECU Identification.....	3-91
ECU Removal.....	3-91
ECU Installation.....	3-92
ECU Power Supply Inspection.....	3-93
CAN Communication Line Resistance Inspection.....	3-95
DFI Power Source.....	3-97
ECU Fuse Removal.....	3-97
ECU Fuse Installation.....	3-97
ECU Fuse Inspection.....	3-97
Warning Indicator Light (LED).....	3-98
Light (LED) Inspection.....	3-98
Fuel Line.....	3-99
Fuel Pressure Inspection.....	3-99
Fuel Flow Rate Inspection.....	3-100
Fuel Pump.....	3-103
Fuel Pump Removal.....	3-103
Fuel Pump Installation.....	3-103
Operation Inspection.....	3-104
Operating Voltage Inspection.....	3-104
Fuel Injectors.....	3-106
Removal/Installation.....	3-106
Power Source Voltage Inspection.....	3-106
Output Voltage Inspection.....	3-107
Audible Inspection.....	3-108

Injector Signal Test.....	3-109
Injector Resistance Inspection.....	3-109
Injector Unit Test.....	3-110
Injector Fuel Line Inspection.....	3-110
Throttle Grip and Cables.....	3-112
Free Play Inspection.....	3-112
Free Play Adjustment.....	3-112
Cable Installation.....	3-112
Cable Lubrication.....	3-112
Throttle Body Assy.....	3-113
Idle Speed Inspection.....	3-113
Throttle Bore Cleaning.....	3-113
Synchronization Inspection.....	3-113
Synchronization Adjustment.....	3-113
Throttle Body Assy Removal.....	3-113
Throttle Body Assy Installation.....	3-116
Throttle Body Assy Disassembly.....	3-118
Throttle Body Assy Assembly.....	3-119
Air Line.....	3-121
Element Removal.....	3-121
Element Installation.....	3-121
Air Cleaner Element Inspection.....	3-121
Air Cleaner Element Holder Removal.....	3-121
Air Cleaner Element Holder Installation.....	3-121
Oil Draining.....	3-122
Rear Air Inlet Duct Removal.....	3-122
Rear Air Inlet Duct Installation.....	3-122
Front and Middle Air Inlet Duct Removal.....	3-123
Front and Middle Air Inlet Duct Installation.....	3-123
Fuel Tank.....	3-125
Fuel Tank Removal.....	3-125
Fuel Tank Installation.....	3-127
Fuel Tank and Cap Inspection.....	3-129
Fuel Tank Cleaning.....	3-129
Evaporative Emission Control System.....	3-130
Parts Removal/Installation.....	3-130
Hose Inspection.....	3-130
Separator Inspection.....	3-130
Separator Operation Test.....	3-131
Canister Inspection.....	3-131

3-4 FUEL SYSTEM (DFI)

Exploded View

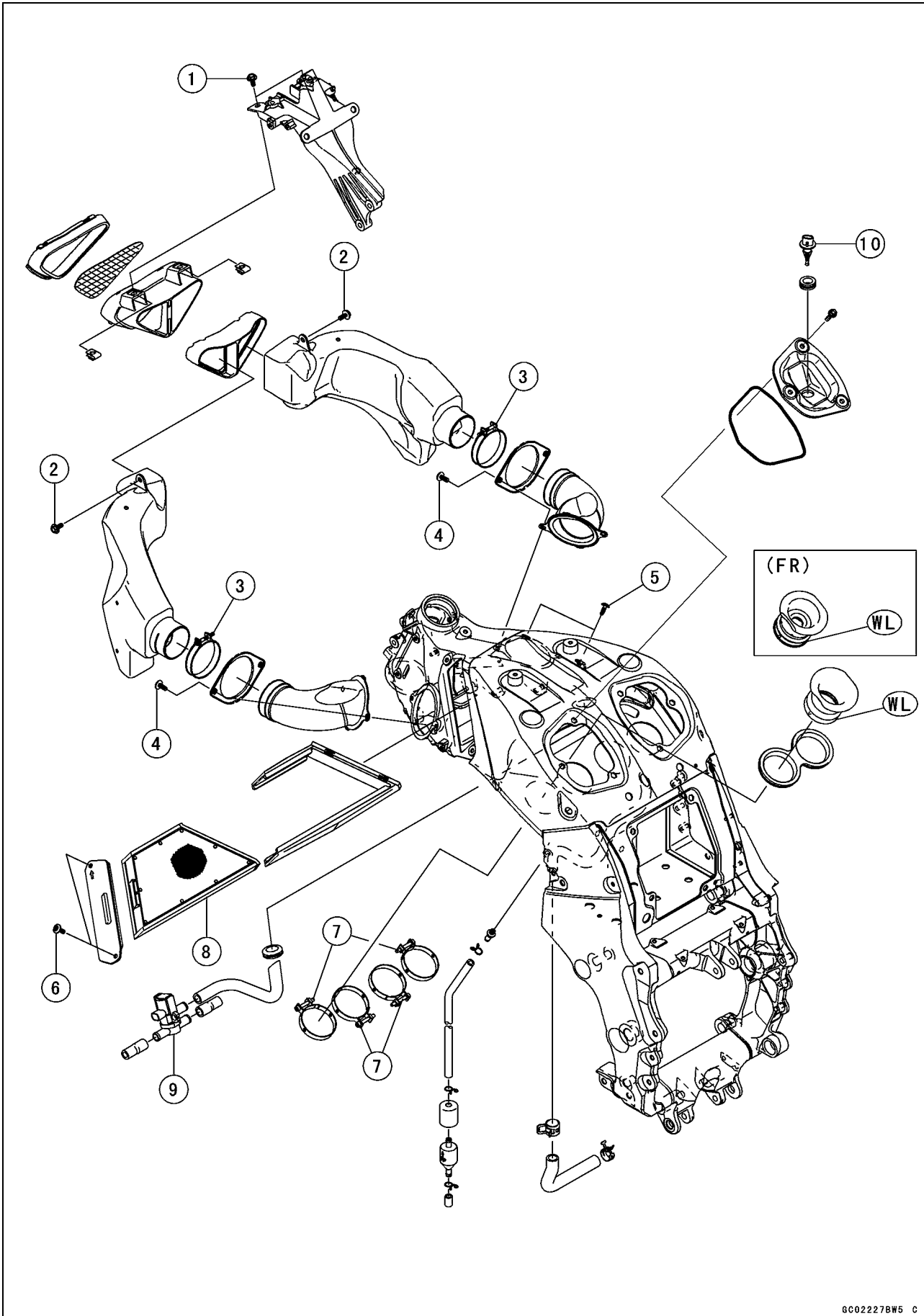

Exploded View

No.	Fastener	Torque			Remarks
		N·m	kgf·m	ft·lb	
1	Front Air Inlet Duct Mounting Bolts	9.8	1.0	87 in·lb	
2	Middle Air Inlet Duct Mounting Bolts	9.8	1.0	87 in·lb	
3	Middle Air Inlet Duct Clamp Bolts	2.9	0.30	26 in·lb	
4	Rear Air Inlet Duct Mounting Bolts	9.8	1.0	87 in·lb	
5	Air Cleaner Element Holder Screws	6.9	0.70	61 in·lb	
6	Air Cleaner Element Cover Bolts	6.9	0.70	61 in·lb	
7	Duct Clamp Bolts	2.0	0.20	18 in·lb	

8. Air Cleaner Element

9. Air Switching Valve

10. Air Inlet Temperature Sensor

L: Apply a non-permanent locking agent.

WL: Apply a soap and water solution or rubber lubricant.

3-6 FUEL SYSTEM (DFI)

Exploded View

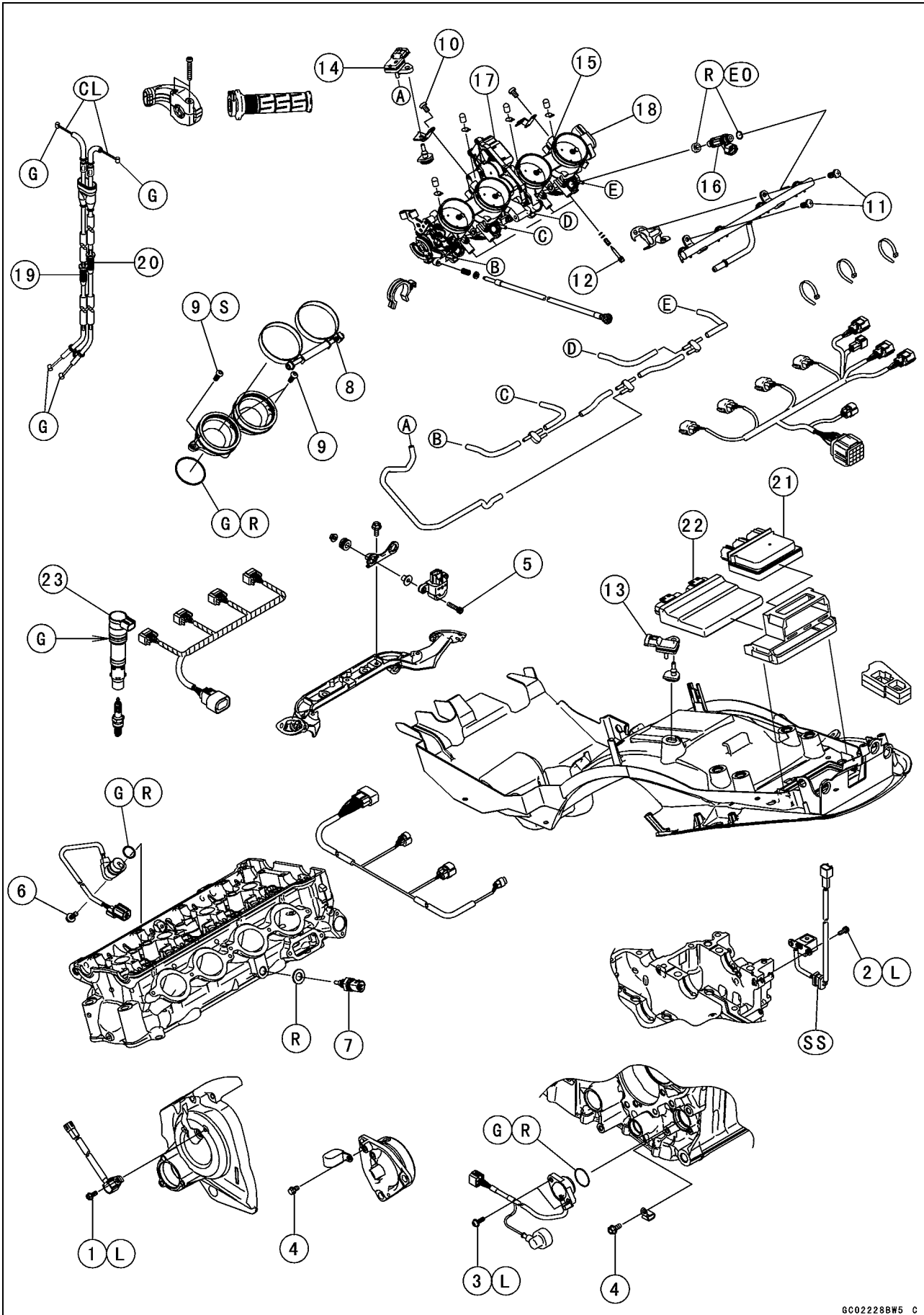

Exploded View

No.	Fastener	Torque			Remarks
		N·m	kgf·m	ft·lb	
1	Speed Sensor Bolt	3.9	0.40	35 in·lb	L
2	Crankshaft Sensor Bolts	5.9	0.60	52 in·lb	L
3	Gear Position Switch Screws	2.9	0.30	26 in·lb	L
4	Gear Position Switch Lead Clamp Bolts	9.8	1.0	87 in·lb	
5	Vehicle-down Sensor Bolts	5.9	0.60	52 in·lb	
6	Camshaft Position Sensor Bolt	9.8	1.0	87 in·lb	
7	Water Temperature Sensor	25	2.5	18	
8	Throttle Body Assy Holder Clamp Bolts	2.0	0.20	18 in·lb	
9	Throttle Body Assy Holder Bolts	9.8	1.0	87 in·lb	S
10	Inlet Air Pressure Sensor Bracket Screws	3.5	0.36	31 in·lb	
11	Delivery Pipe Mounting Screws	5.0	0.51	44 in·lb	
12	Bypass Screws	0.2	0.02	1.8 in·lb	

- 13. Atmospheric Pressure Sensor
- 14. Inlet Air Pressure Sensor
- 15. Main Throttle Sensor
- 16. Fuel Injectors
- 17. Subthrottle Valve Actuator
- 18. Subthrottle Sensor
- 19. Throttle Cable (Accelerator)
- 20. Throttle Cable (Decelerator)
- 21. Relay Box
- 22. ECU
- 23. Stick Coils

CL: Apply cable lubricant.

EO: Apply engine oil.

G: Apply grease.

L: Apply a non-permanent locking agent.

R: Replacement Parts

S: Follow the specified tightening sequence.

3-8 FUEL SYSTEM (DFI)

Exploded View

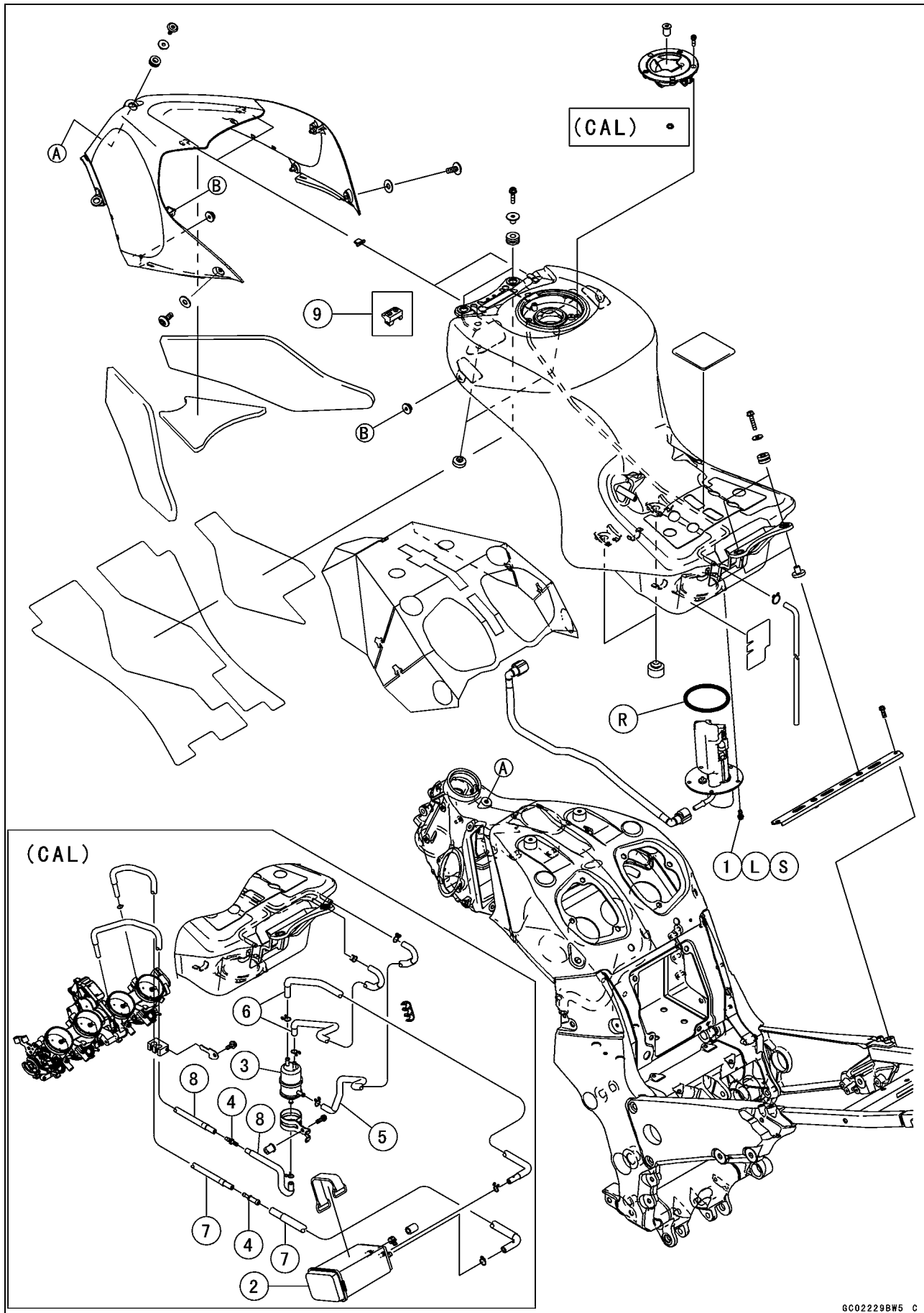

Exploded View

No.	Fastener	Torque			Remarks
		N·m	kgf·m	ft·lb	
1	Fuel Pump Bolts	9.8	1.0	87 in·lb	L, S

- 2. Canister
 - 3. Separator
 - 4. Fitting
 - 5. Red Hose
 - 6. Blue Hose
 - 7. Green Hose
 - 8. White Hose
 - 9. Damper (ZX1400B Models)
- L: Apply a non-permanent locking agent.
R: Replacement Parts
S: Follow the specified tightening sequence.

3-10 FUEL SYSTEM (DFI)

DFI System

DFI System

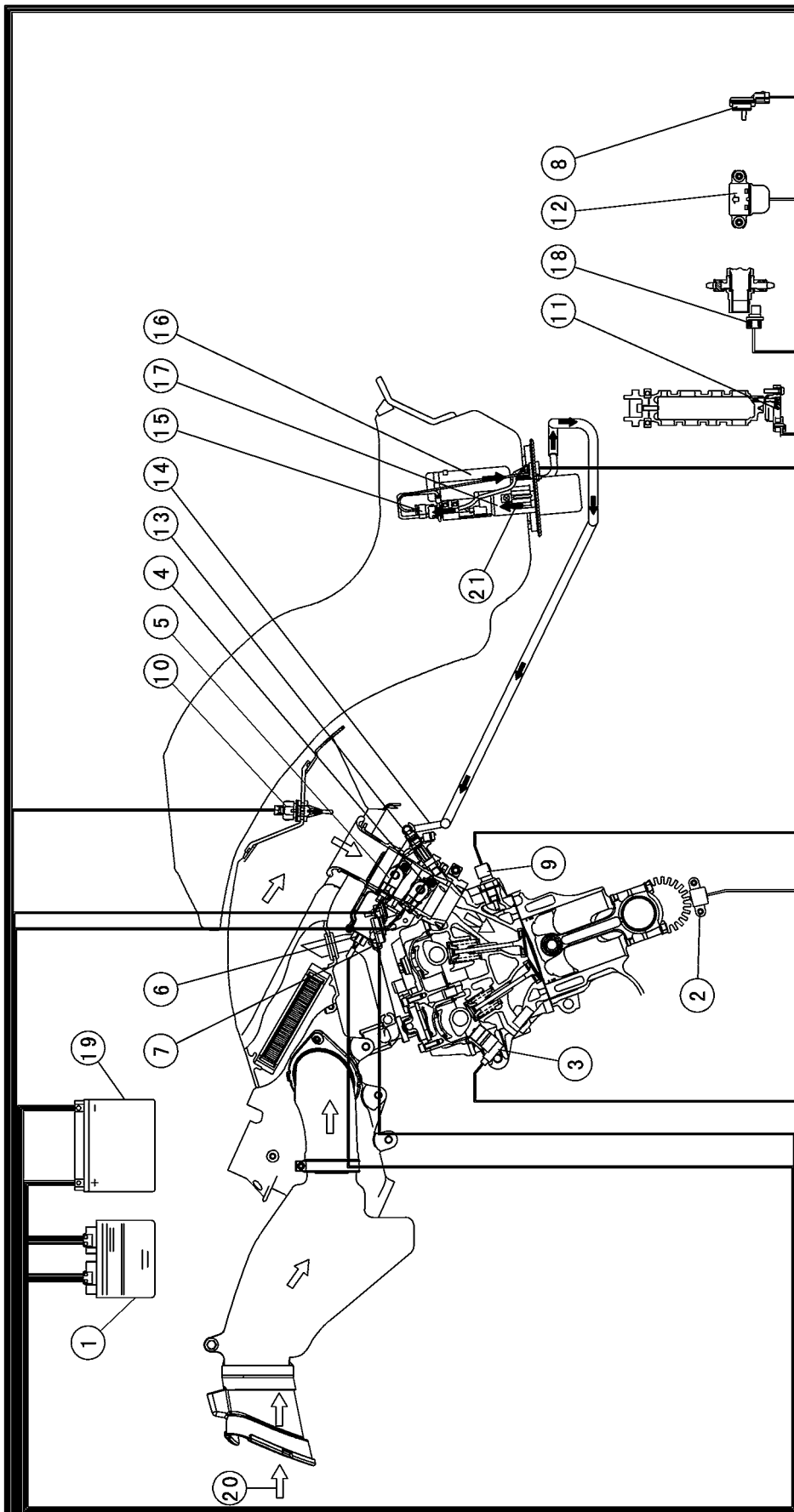

DFI System

1. ECU
2. Crankshaft Sensor
3. Camshaft Position Sensor
4. Main Throttle Sensor
5. Subthrottle Sensor
6. Subthrottle Valve Actuator
7. Inlet Air Pressure Sensor
8. Atmospheric Pressure Sensor
9. Water Temperature Sensor
10. Inlet Air Temperature Sensor
11. Gear Position Switch
12. Vehicle-down Sensor
13. Fuel Injectors
14. Delivery Pipe
15. Pressure Regulator
16. Fuel Pump
17. Fuel Filter
18. Speed Sensor
19. Battery 12 V 14 Ah
20. Air Flow
21. Fuel Flow

3-12 FUEL SYSTEM (DFI)

DFI System

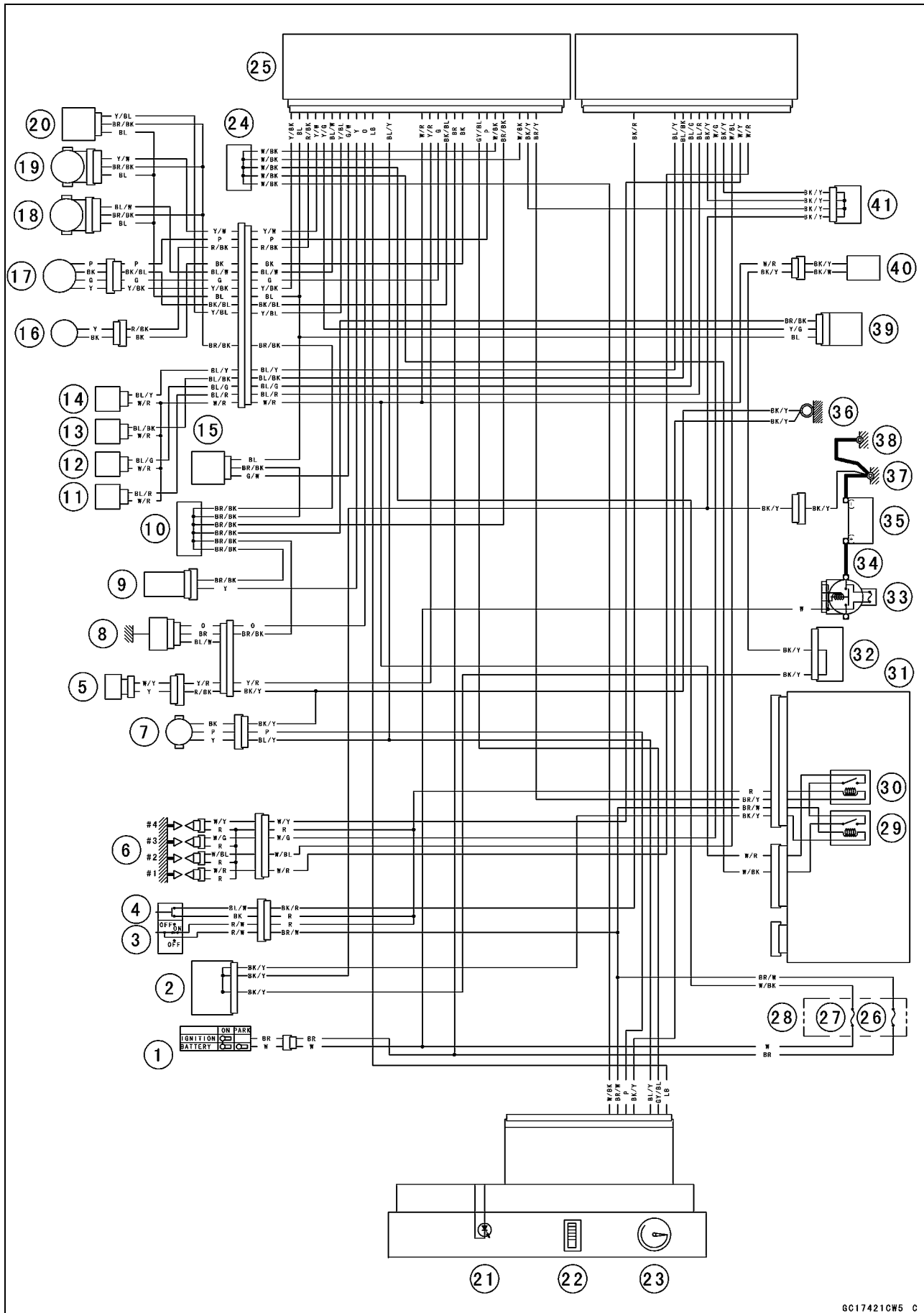

DFI System

Part Name

1. Ignition Switch
2. Joint Connector 1
3. Engine Stop Switch
4. Starter Button
5. Camshaft Position Sensor
6. Stick Coil #1, #2, #3, #4
7. Speed Sensor
8. Water Temperature Sensor
9. Inlet Air Temperature Sensor
10. Water-proof Joint 2
11. Injector #1
12. Injector #2
13. Injector #3
14. Injector #4
15. Atmospheric Pressure Sensor
16. Crankshaft Sensor
17. Subthrottle Valve Actuator
18. Subthrottle Sensor
19. Main Throttle Sensor
20. Inlet Air Pressure Sensor
21. Warning Indicator Light (LED)
22. Water Temperature Gauge
23. Speedmeter
24. Water-proof Joint 1
25. ECU
26. ECU Fuse15 A
27. Ignition Fuse 10 A
28. Fuse Box 2
29. Main Relay
30. Fuel Pump Relay
31. Relay Box
32. Joint Connector 2
33. Main Fuse 30 A
34. Starter Relay
35. Battery 12 V 14 Ah
36. Frame Ground 1
37. Frame Ground 2
38. Engine Ground
39. Vehicle-down Sensor
40. Fuel Pump
41. Joint Connector 3

3-14 FUEL SYSTEM (DFI)

DFI System

Terminal Numbers of ECU Connectors

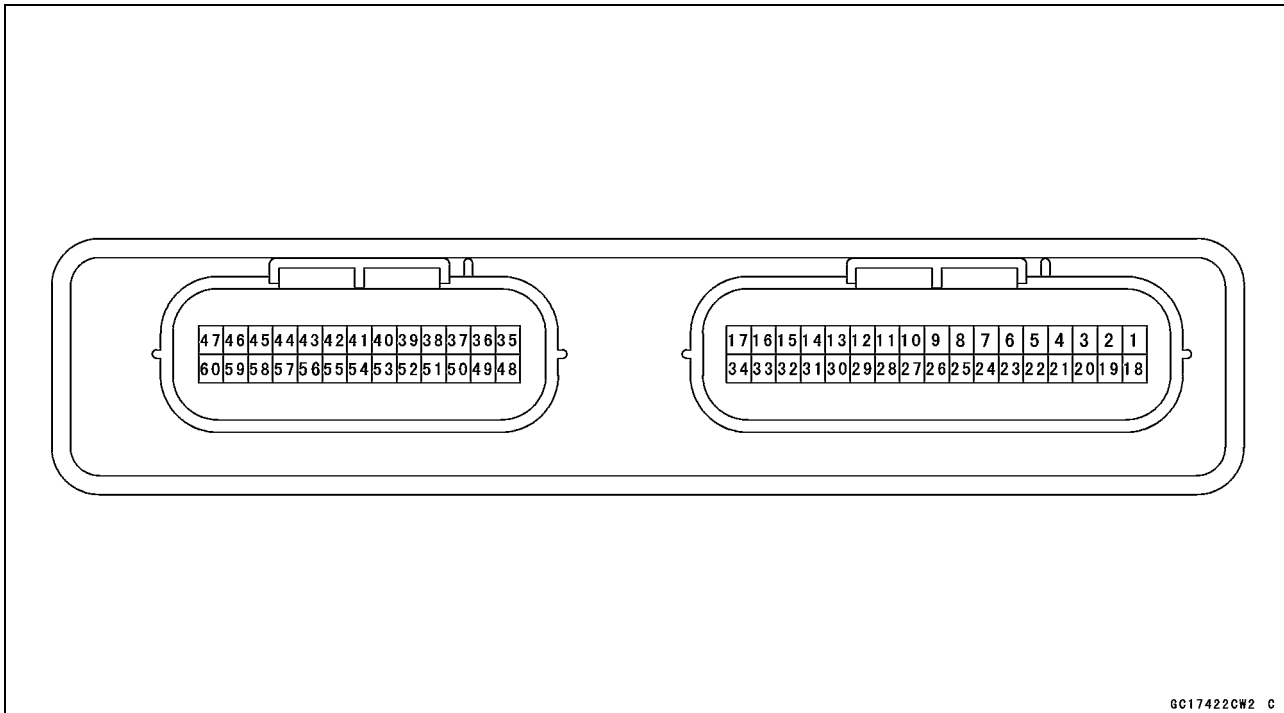

GC17422CW2 C

Terminal Names

1. CAN Communication Line (High)
2. Subthrottle Valve Actuator
3. Subthrottle Valve Actuator
4. Gear Position Switch
5. Crankshaft Sensor (-)
6. Speed Sensor
7. Power Supply to Sensors
8. Inlet Air Temperature Sensor
9. Vehicle-down Sensor
10. Unused
11. Atmospheric Pressure Sensor
12. Unused
13. Fuel Pump Relay
14. Battery Monitor
15. Power Supply to ECU (from Battery)
16. Unused
17. Ground for Control System
18. CAN Communication Line (Low)
19. Subthrottle Valve Actuator
20. Subthrottle Valve Actuator
21. External Communication Line (Immobilizer/*KDS)
22. Crankshaft Sensor (+)
23. Unused
24. Camshaft Position Sensor
25. Water Temperature Sensor
26. Main Throttle Sensor
27. Subthrottle Sensor
28. Inlet Air Pressure Sensor
29. Unused
30. Radiator Fan Relay
31. Unused
32. Power Supply to ECU (from Battery)
33. Ignition Switch
34. Ground for Sensors

DFI System

35. External Communication Line (Immobilizer/*KDS)
36. Immobilizer Amplifier
37. Unused
38. Air Switching Valve
39. Engine Ground
40. Starter Lockout Switch
41. Unused
42. Starter Button
43. Unused
44. Injector #3
45. Stick Coil #3
46. Injector #1
47. Stick Coil #1
48. Unused
49. Immobilizer Amplifier
50. Immobilizer Amplifier
51. Unused
52. Engine Ground
53. Sidestand Switch
54. Unused
55. Ground
56. Unused
57. Injector #4
58. Ignition Coil #4
59. Injector #2
60. Ignition Coil #2

* KDS (Kawasaki Diagnostic System)

KDS that runs on Windows personal computer (PC) diagnostic tool for motorcycle with Kawasaki DFI system.

3-16 FUEL SYSTEM (DFI)

DFI Parts Location

Main Throttle Sensor [A]
Subthrottle Sensor [B]
Subthrottle Valve Actuator [C]
Water Temperature Sensor [D]
Battery [E]

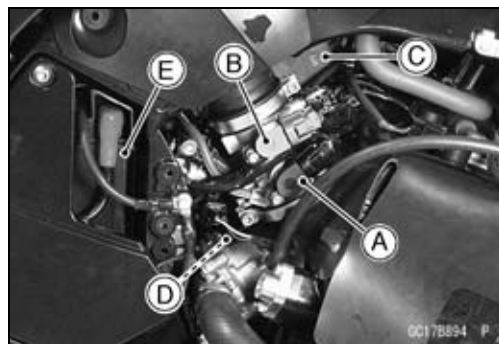

Fuel Injectors #1, #2, #3, #4 [A]



Relay Box (Fuel Pump Relay) [A]
Immobilizer/Kawasaki Diagnostic System Connector [B]
Atmospheric Pressure Sensor [C]
ECU [D]
Fuse Box (ECU Fuse 15 A) [E]

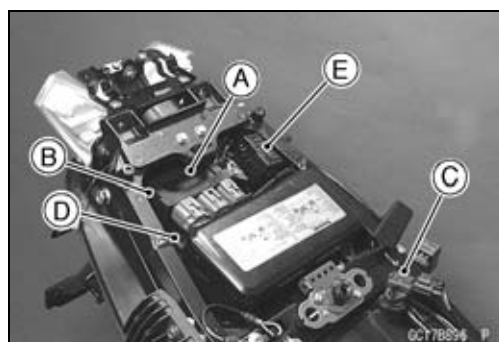

Stick Coils #1, #2, #3, #4 [A]



Inlet Air Temperature Sensor [A]

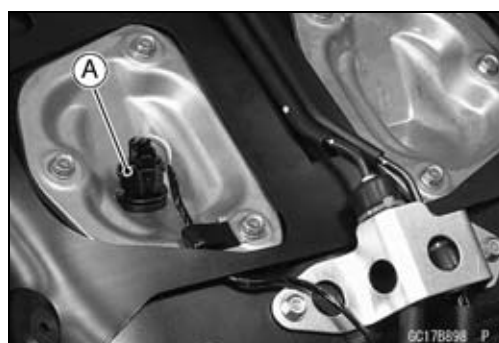

DFI Parts Location

Camshaft Position Sensor [A]
Crankshaft Sensor [B]

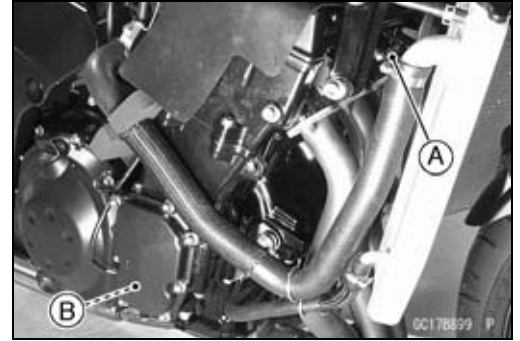

Speed Sensor [A]
Gear Position Switch [B]

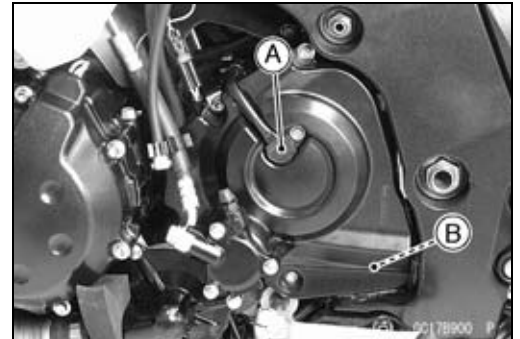

Ignition Key [A] (Transponder, Immobilizer Models)
Ignition Switch [B]
Immobilizer Antenna [C] (Immobilizer Models)
Immobilizer Amplifier [D] (Immobilizer Models)
Vehicle-down [E]

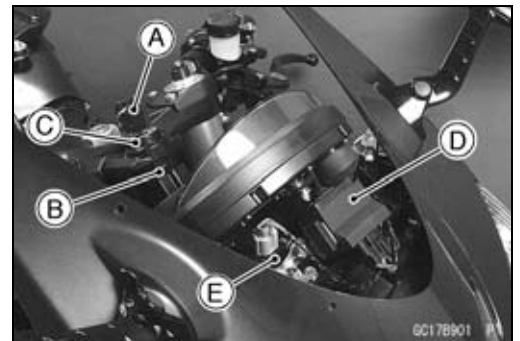

Inlet Air Pressure Sensor [A]

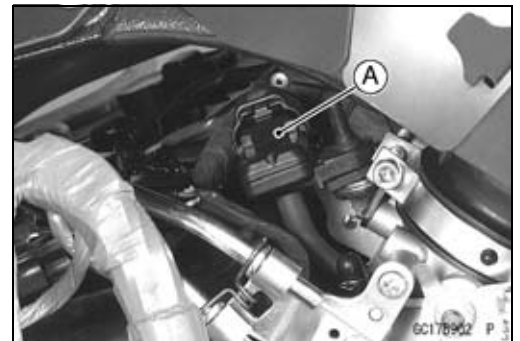

Fuel Pump [A]



3-18 FUEL SYSTEM (DFI)

Specifications

Item	Standard
Digital Fuel Injection System	
Idle Speed	1 100 ±50 r/min (rpm)
Throttle Assy:	
Type	Four barrel type
Bore	φ44 mm (1.7 in.)
Throttle Body Vacuum	39 ±1.33 kPa (293 ±10 mmHg)
Bypass Screws	- - -
ECU:	
Make	Mitsubishi Electric
Type	Digital memory type, with built in IC igniter, sealed with resin
Usable Engine Speed	100 ~ 12 000 r/min (rpm)
Fuel Pressure (high pressure line):	
Right after Ignition Switch ON, with fuel pump running for 3 seconds with engine idling	304 kPa (3.1 kgf/cm ² , 44 psi) with fuel pump running 280 kPa (2.9 kgf/cm ² , 41 psi) with fuel pump stopped 304 kPa (3.1 kgf/cm ² , 44 psi) with fuel pump running
Fuel Pump:	
Type	In-tank pump (in fuel tank), or Wesco pump (friction pump)
Discharge	67 mL (2.26 US oz.) or more for 3 seconds
Fuel Injectors:	
Type	INP-286
Nozzle Type	One spray type with 10 holes
Resistance	About 11.7 ~ 12.3 Ω at 20°C (68°F)
Main Throttle Sensor:	Non-adjustable and non-removable
Input Voltage	DC 4.75 ~ 5.25 V between BL and BR/BK leads
Output Voltage	DC 0.63 ~ 3.91 V between Y/W and BR/BK leads (at idle throttle opening to full throttle opening)
Resistance	4 ~ 6 kΩ
Inlet Air Pressure Sensor/Atmospheric Pressure Sensor:	
Input Voltage	DC 4.75 ~ 5.25 V between BL and BR/BK leads
Output Voltage	DC 3.80 ~ 4.20 V at standard atmospheric pressure (see this text for details)
Inlet Air Temperature Sensor:	
Resistance	2.09 ~ 2.81 kΩ at 20°C (68°F) About 0.322 kΩ at 80°C (176°F) (reference value)
Output Voltage at ECU	About 2.25 ~ 2.50 V at 20°C (68°F)
Water Temperature Sensor:	
Resistance	see Electrical System chapter
Output Voltage at ECU	About 2.80 ~ 2.97 V at 20°C (68°F)
Speed Sensor:	
Input Voltage at Sensor	About DC 9 ~ 11 V at Ignition Switch ON
Output Voltage at Sensor	About DC 0.05 ~ 0.09 V or DC 4.5 ~ 4.9 at Ignition Switch ON and 0 km/h

Specifications

Item	Standard
Vehicle-down sensor: Detection Method Detection Angle Output Voltage Subthrottle Sensor: Input Voltage Output Voltage Resistance Immobilizer Antenna: Resistance Subthrottle Valve Actuator: Resistance Input Voltage CAN Communication Line: Resistance	Magnetic flux detection method More than 60 ~ 70° for each bank with sensor arrow mark pointed up: 3.55 ~ 4.45 V with sensor tilted 60 ~ 70° or more: 0.65 ~ 1.35 V Non-adjustable and non-removal DC 4.75 ~ 5.25 V between BL and BR/BK leads DC 0.62 ~ 4.14 V between BL/W and BR/BK leads (at idle throttle opening to full throttle opening) 4 ~ 6 kΩ About 0.6 ~ 0.9 Ω About 5 ~ 7 Ω About DC 10.5 ~ 12.5 V 114 ~ 126 Ω at ECU Connector
Throttle Grip and Cables Throttle Grip Free Play	2 ~ 3 mm (0.08 ~ 0.12 in.)

3-20 FUEL SYSTEM (DFI)

Special Tools and Sealant

Oil Pressure Gauge, 5 kgf/cm²:
57001-125

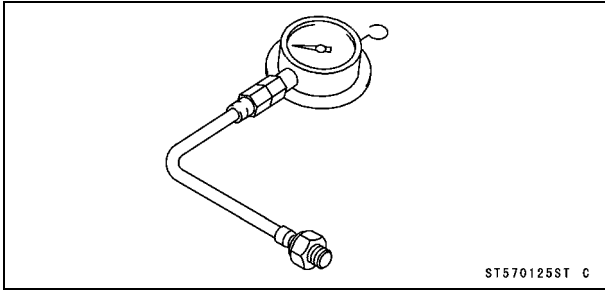

Peak Voltage Adapter:
57001-1415

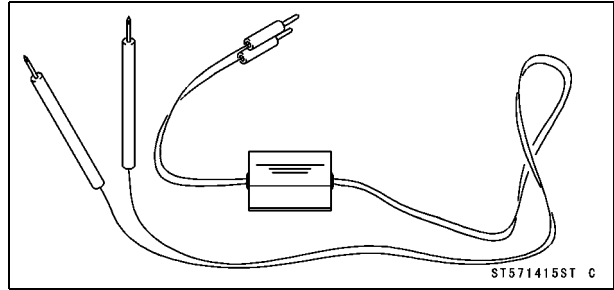

Fork Oil Level Gauge:
57001-1290

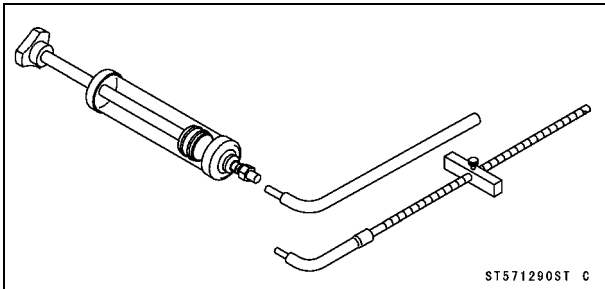

Needle Adapter Set:
57001-1457

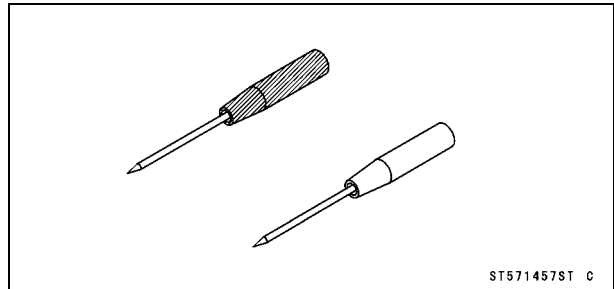

Vacuum Gauge:
57001-1369

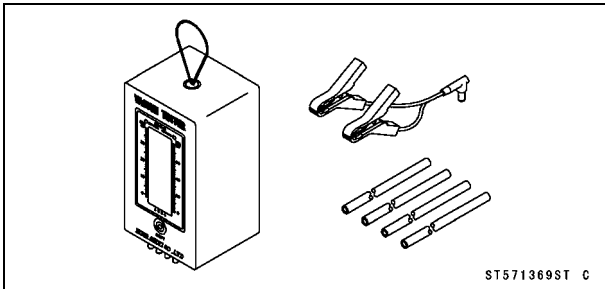

Throttle Sensor Setting Adapter:
57001-1538

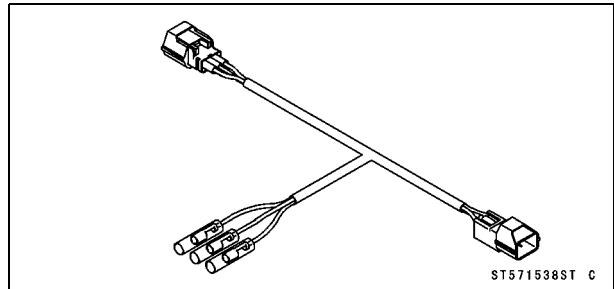

Hand Tester:
57001-1394

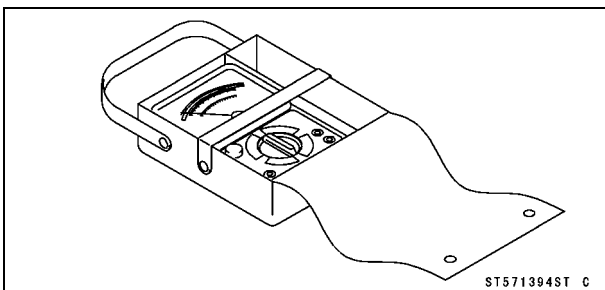

Sensor Harness Adapter:
57001-1561

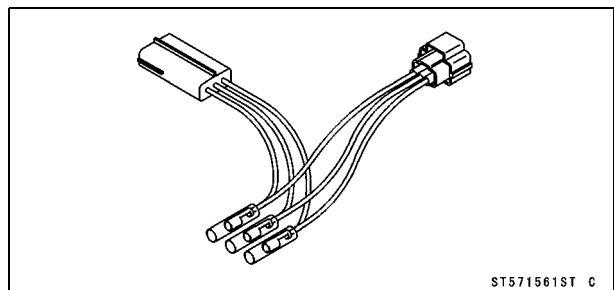

Throttle Sensor Setting Adapter #1:
57001-1400

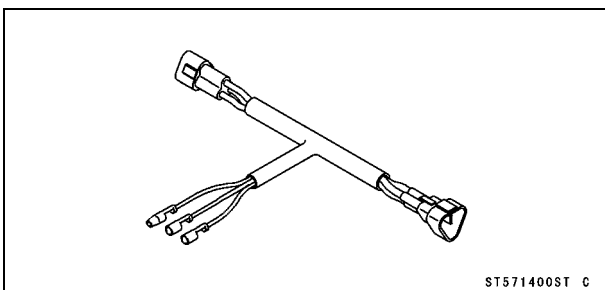

Fuel Pressure Gauge Adapter:
57001-1593

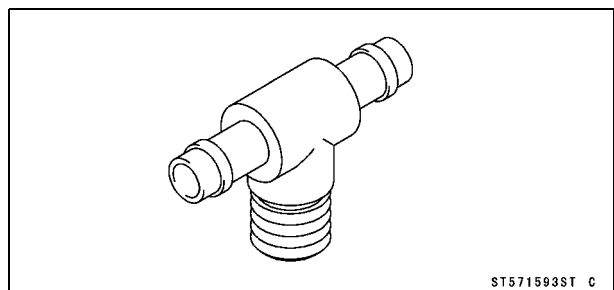

Special Tools and Sealant

Fuel Hose:
57001-1607

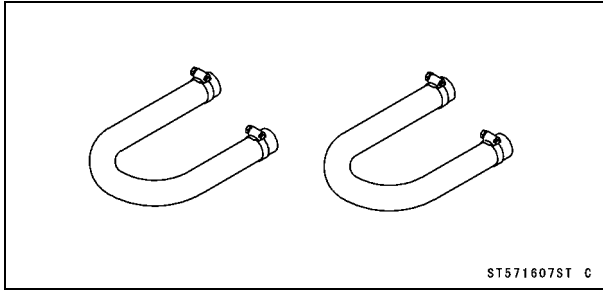

Kawasaki Bond (Silicone Sealant):
56019-120

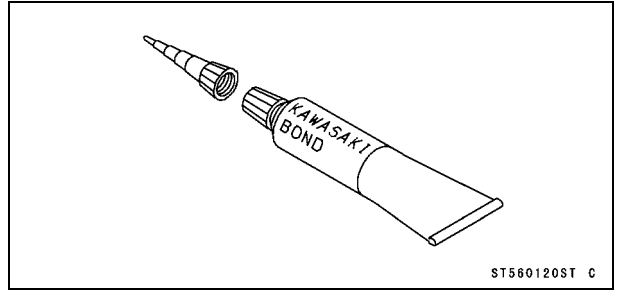

3-22 FUEL SYSTEM (DFI)

DFI Servicing Precautions

DFI Servicing Precautions

There are a number of important precautions that should be followed servicing the DFI system.

- This DFI system is designed to be used with a 12 V sealed battery as its power source. Do not use any other battery except for a 12 V sealed battery as a power source.
- Do not reverse the battery cable connections. This will damage the ECU.
- To prevent damage to the DFI parts, do not disconnect the battery cables or any other electrical connections when the ignition switch is on, or while the engine is running.
- Take care not to short the leads that are directly connected to the battery positive (+) terminal to the chassis ground.
- When charging, remove the battery from the motorcycle. This is to prevent ECU damage by excessive voltage.
- Whenever the DFI electrical connections are to be disconnected, first turn off the ignition switch, and disconnect the battery (–) terminal. Do not pull the lead, only the connector. Conversely, make sure that all the DFI electrical connections are firmly reconnected before starting the engine.
- Connect these connectors until they click [A]

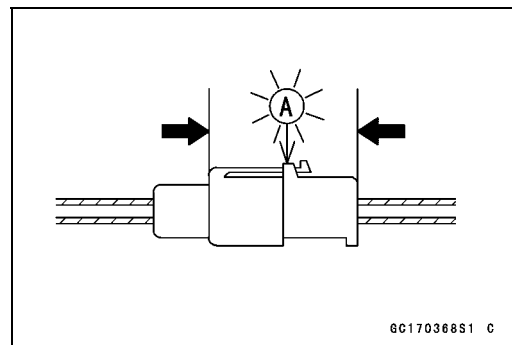

- Do not turn the ignition switch ON while any of the DFI electrical connectors are disconnected. The ECU memorizes service codes.
- Do not spray water on the electrical parts, DFI parts, connectors, leads, and wiring.
- If a transceiver is installed on the motorcycle, make sure that the operation of the DFI system is not influenced by electric wave radiated from the antenna. Check operation of the system with the engine at idle. Locate the antenna as far as possible away from the ECU.
- When any fuel hose is disconnected, do not turn on the ignition switch. Otherwise, the fuel pump will operate and fuel will spout from the fuel hose.
- Do not operate the fuel pump if the pump is completely dry. This is to prevent pump seizure.

DFI Servicing Precautions

- Before removing the fuel system parts, blow the outer surfaces of these parts clean with compressed air.
- When any fuel hose is disconnected, fuel may spout out by residual pressure in the fuel line. Cover the hose joint with a piece of clean cloth to prevent fuel spillage.
- When installing the fuel hoses, avoid sharp bending, kinking, flattening or twisting, and route the fuel hoses with a minimum of bending so that the fuel flow will not be obstructed.
- Route the hoses according to Cable, Wire, and Hose Routing section in the Appendix chapter.
- To prevent corrosion and deposits in the fuel system, do not add to fuel any fuel antifreeze chemicals.
- Replace the fuel hose if it has been sharply bent or kinked.
- If the motorcycle is not properly handled, the high pressure inside the fuel line can cause fuel to leak or the hose [A] to burst. Bend and twist the fuel hose while examining it.
- ★ Replace the hose if any cracks or bulges are noticed.

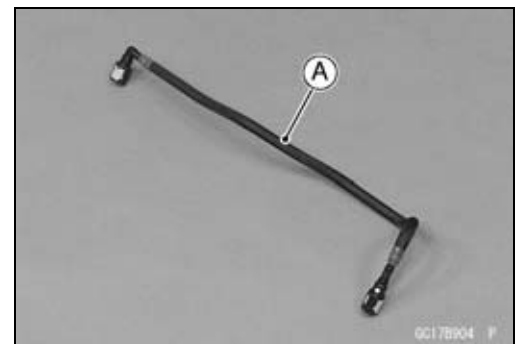

- To maintain the correct fuel/air mixture (F/A), there must be no inlet air leaks in the DFI system. Be sure to install the oil filler plug [A] after filling the engine oil.
Clutch Cover [B]

Torque - Oil Filler Plug: Hand-tighten

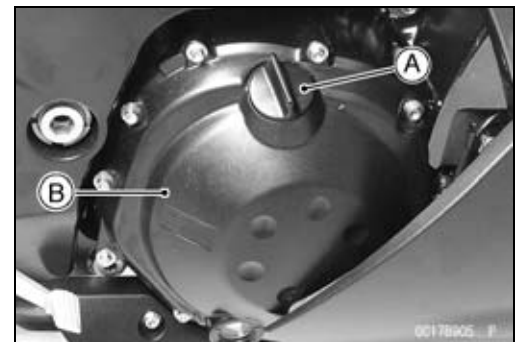

3-24 FUEL SYSTEM (DFI)

Troubleshooting the DFI System

Outline

When a problem occurs with DFI system, the warning indicator (LED) [A] goes on and FI warning message [B] and FI warning symbol [C] are displayed alternately on the LCD (Liquid Crystal Display) to alert the rider.

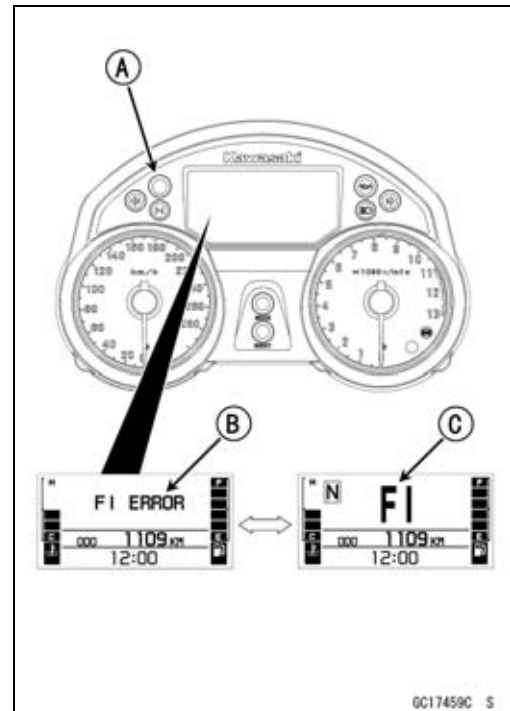

For models equipped with an immobilizer system, the warning indicator light [A] blinks and immobilizer warning message [B] and immobilizer warning symbol [C] are alternately displayed on the LCD, when a problem occurs in the system.

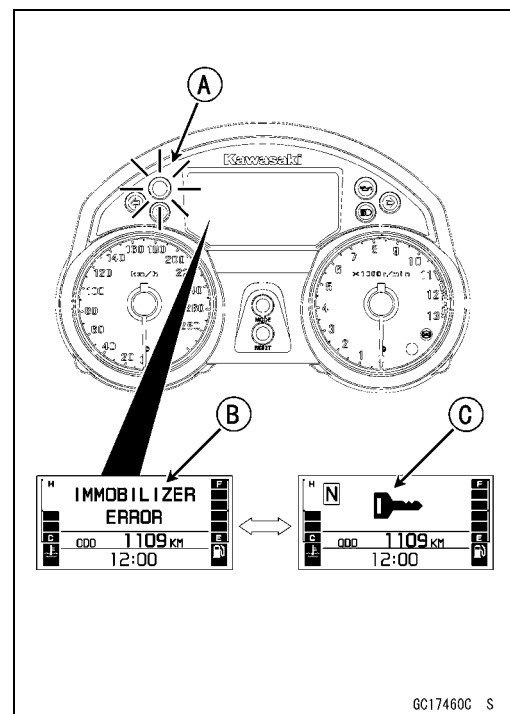

Troubleshooting the DFI System

With the engine stopped and turned in the self-diagnosis mode, the service code (error code) [A] is displayed on the LCD by the number of two digits.

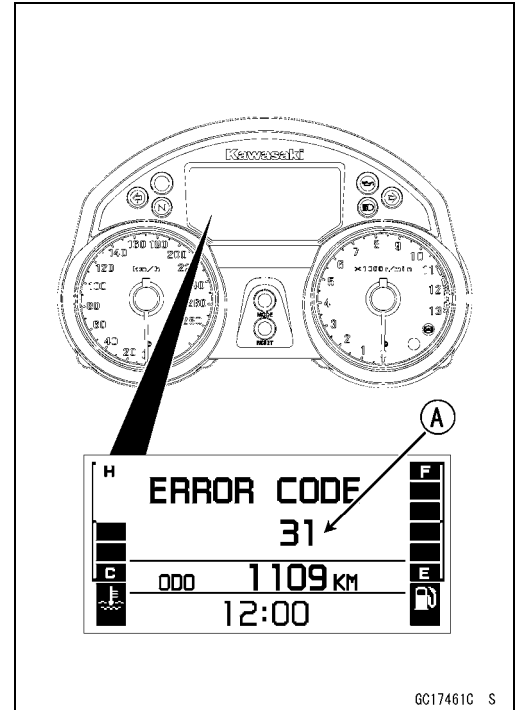

When the service code [A] is displayed, for first ask the rider about the conditions [B] of trouble, and then start to determine the cause [C] of problem.

As a pre-diagnosis inspection, check the ECU for ground and power supply, the fuel line for no fuel leaks, and for correct pressure. The pre-diagnosis items are not indicated by the warning indicator light (LED), FI warning message and FI warning symbol.

Don't rely solely on the DFI self-diagnosis function, use common sense.

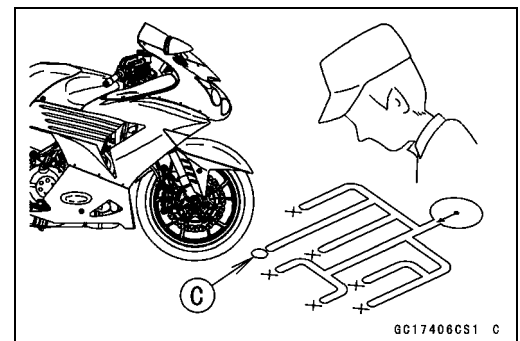
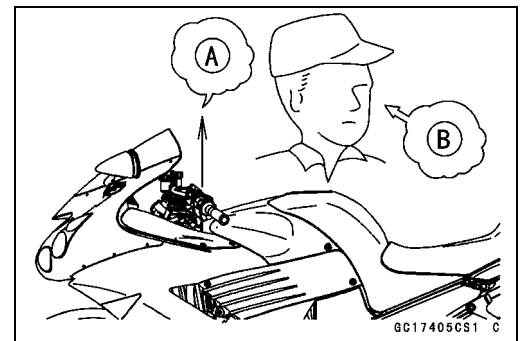

3-26 FUEL SYSTEM (DFI)

Troubleshooting the DFI System

Even when the DFI system is operating normally, the warning indicator light (LED) goes on and FI warning message and FI warning symbol may be displayed under strong electrical interference. Additional measures are not required. Turn the ignition switch OFF to stop the indicator light, message and symbol.

If the warning indicator light (LED) of the motorcycle brought in for repair still goes on, check the service code.

When the repair has been done, the warning indicator light (LED) goes off and FI warning message and FI warning symbol are not displayed on the LCD. But the service codes stored in memory of the ECU are not erased to preserve the problem history. The problem history can be referred using the KDS (Kawasaki Diagnostic System) when solving unstable problems

Much of the DFI system troubleshooting work consists of confirming continuity of the wiring. The DFI parts are assembled and adjusted with precision, and it is impossible to disassemble or repair them.

- When checking the DFI parts, use a digital meter which can be read two decimal place voltage or resistance.
- The DFI part connectors have seals, including the ECU. When measuring the input or output voltage with the connector joined, use the needle adapter set. Insert the needle adapter inside the seal until the needle adapter reaches the terminal.

Special Tool - Needle Adapter Set: 57001-1457

CAUTION

Insert the needle adapter straight along the terminal in the connector to prevent short-circuit between terminals.

- After measurement, remove the needle adapters and apply silicone sealant to the seals [A] of the connector [B] for waterproofing.

**Sealant - Kawasaki Bond (Silicone Sealant): 56019-120
-Seals of Connector**

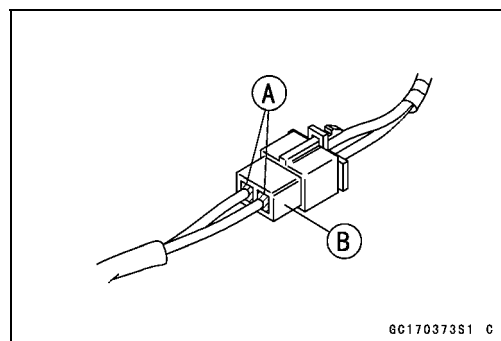

Troubleshooting the DFI System

- Always check battery condition before replacing the DFI parts. A fully charged battery is a must for conducting accurate tests of the DFI system.
- Trouble may involve one or in some cases all items. Never replace a defective part without determining what CAUSED the problem. If the problem was caused by some other item or items, they too must be repaired or replaced, or the new replacement part will soon fail again
- Measure coil winding resistance when the DFI part is cold (at room temperature)
- Do not adjust or remove the throttle sensor.
- Do not directly connect a 12 V battery to a fuel injector. Insert a resistor (5 ~ 7 Ω) or a bulb (12 V \times 3 ~ 3.4 W) in series between the battery and the injector.
- The DFI parts have been adjusted and set with precision. Therefore, they should be handled carefully, never strike sharply, as with a hammer, or allowed to drop on a hard surface. Such a shock to the parts can damage them.
- Check wiring and connections from the ECU connector to the suspected faulty DFI parts, using the hand tester (special tool, analog tester) rather than a digital tester.

Special Tool - Hand Tester: 57001-1394

- Make sure all connectors in the circuit are clean and tight, and examine wires for signs of burning, fraying, etc. Deteriorated leads and bad connections can cause reappearance of problems and unstable operation of the DFI system.
- ★ If any wiring is deteriorated, replace the wiring.
- Pull each connector [A] apart and inspect it for corrosion, dirt, and damage.
- ★ If the connector is corroded or dirty, clean it carefully. If it is damaged, replace it. Connect the connectors securely.
- Check the wiring for continuity.
- Use the wiring diagram to find the ends of the lead which is suspected of being a problem.
- Connect the hand tester between the ends of the leads.
- Set the tester to the $\times 1 \Omega$ range, and read the tester.
- ★ If the tester does not read 0 Ω , the lead is defective. Replace the lead or the main harness or the sub harness.

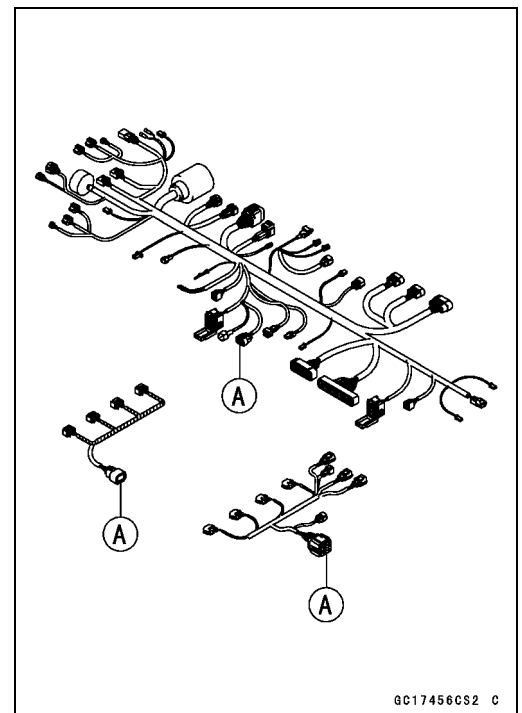

3-28 FUEL SYSTEM (DFI)

Troubleshooting the DFI System

○ If both ends of a harness [A] are far apart, ground [B] the one end [C], using a jumper lead [D] and check the continuity between the end [E] and the ground [F]. This enables to check a long harness for continuity. If the harness is open, repair or replace the harness.

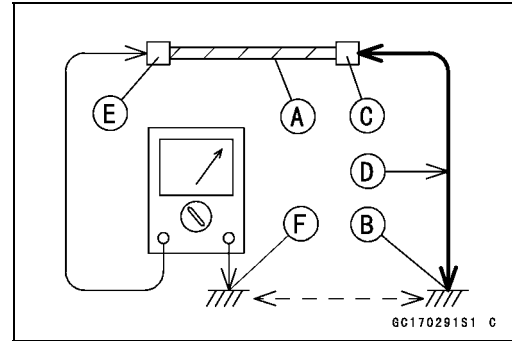

○ When checking a harness [A] for short circuit, open one end [B] and check the continuity between the other end [C] and ground [D]. If there is continuity, the harness has a short circuit to ground, and it must be repaired or replaced.

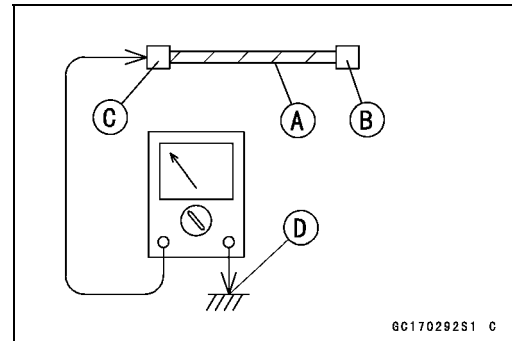

- Narrow down suspicious locations by repeating the continuity tests from the ECU connectors.
- ★ If no abnormality is found in the wiring or connectors, the DFI parts are the next likely suspects. Check the part, starting with input and output voltages. However, there is no way to check the ECU itself.
- ★ If an abnormality is found, replace the affected DFI part.
- ★ If no abnormality is found in the wiring, connectors, and DFI parts, replace the ECU.
- The diagnosis flow chart illustrates the above procedures.
- After inspection, be sure to connect all the DFI electrical connectors. Do not turn the ignition switch ON while the DFI electrical connectors and ignition system connectors are disconnected. Otherwise, the ECU memorizes service codes as open circuit.

○ Lead Color Codes:

BK: Black	G: Green	P: Pink
BL: Blue	GY: Gray	PU: Purple
BR: Brown	LB: Light Blue	R: Red
CH: Chocolate	LG: Light Green	W: White
DG: Dark Green	O: Orange	Y: Yellow

Troubleshooting the DFI System

DFI Diagnosis Flow Chart

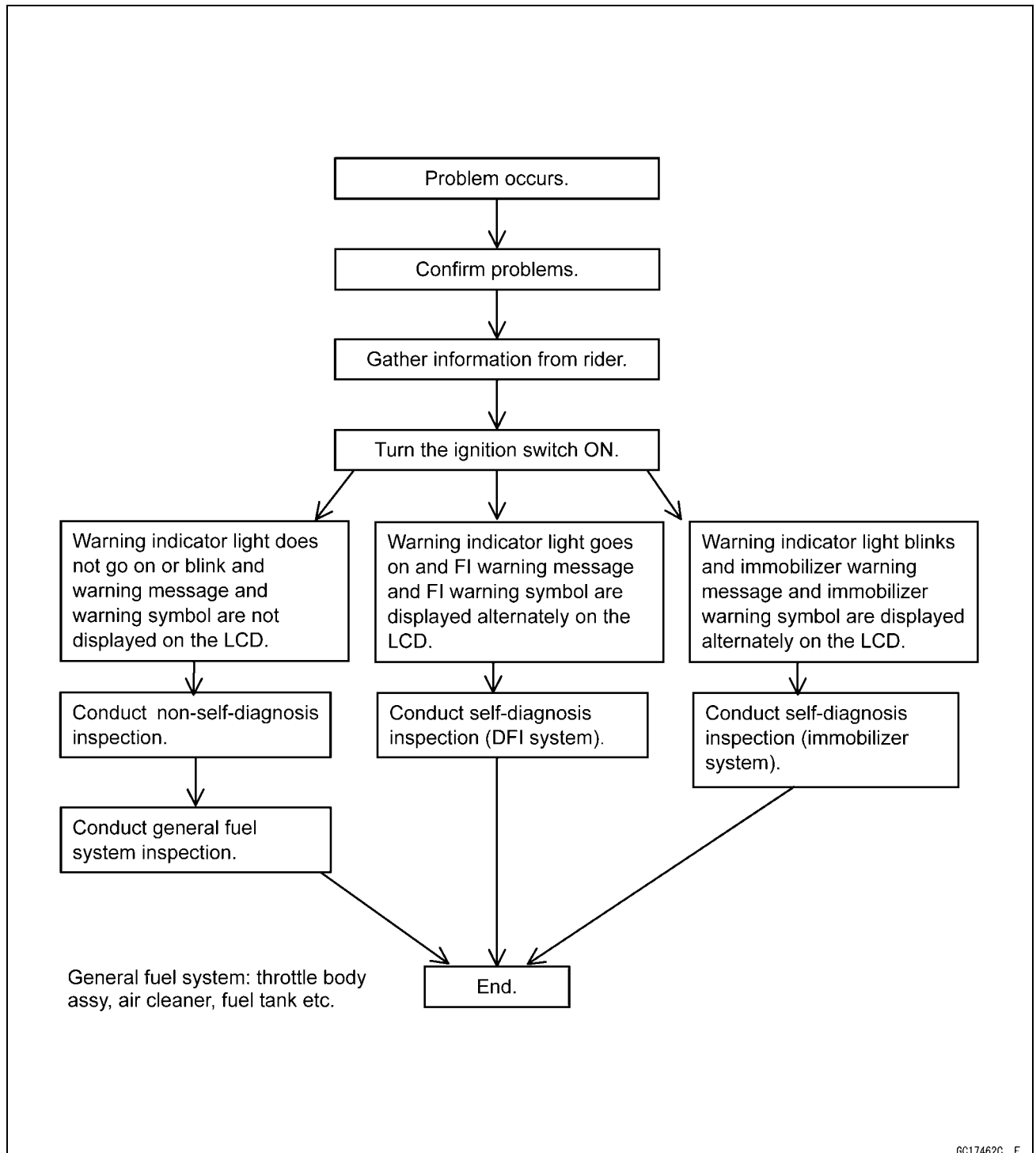

Inquiries to Rider

- Each rider reacts to problems in different ways, so it is important to confirm what kind of symptoms the rider has encountered.
- Try to find out exactly what problem occurred under exactly what conditions by asking the rider; knowing this information may help you reproduce the problem.
- The diagnosis sheet will help prevent you from overlooking any areas, and will help you decide if it is a DFI system problem, or a general engine problem.

3-30 FUEL SYSTEM (DFI)

Troubleshooting the DFI System

Sample Diagnosis Sheet

Rider name:	Registration No. (license plate No.):	Year of initial registration:
Model:	Engine No.:	Frame No.:
Date problem occurred:		Mileage:
Environment when problem occurred.		
Weather	<input type="checkbox"/> fine, <input type="checkbox"/> cloudy, <input type="checkbox"/> rain, <input type="checkbox"/> snow, <input type="checkbox"/> always, <input type="checkbox"/> other:	
Temperature	<input type="checkbox"/> hot, <input type="checkbox"/> warm, <input type="checkbox"/> cold, <input type="checkbox"/> very cold, <input type="checkbox"/> always, <input type="checkbox"/> other:	
Problem frequency	<input type="checkbox"/> chronic, <input type="checkbox"/> often, <input type="checkbox"/> once	
Road	<input type="checkbox"/> street, <input type="checkbox"/> highway, <input type="checkbox"/> mountain road (<input type="checkbox"/> uphill, <input type="checkbox"/> downhill), <input type="checkbox"/> bumpy, <input type="checkbox"/> pebble	
Altitude	<input type="checkbox"/> normal, <input type="checkbox"/> high (about 1000 m or more)	
Motorcycle conditions when problem occurred.		
Warning indicator light (LED)	<input type="checkbox"/> Goes on about 3 seconds after from ignition switch ON, and FI warning message and FI warning symbol are displayed alternately on the LCD (DFI system problem).	
	<input type="checkbox"/> Starts blinking about 3 seconds after from ignition switch ON, and immobilizer warning message and immobilizer warning symbol are displayed alternately on the LCD (Immobilizer system problem).	
	<input type="checkbox"/> Does not go on or blink about 3 seconds after ignition switch ON.	
Starting difficulty	<input type="checkbox"/> starter motor not rotating.	
	<input type="checkbox"/> starter motor rotating but engine doesn't turn over.	
	<input type="checkbox"/> starter motor and engine don't turn over.	
	<input type="checkbox"/> no fuel flow (<input type="checkbox"/> no fuel in tank, <input type="checkbox"/> no fuel pump sound).	
	<input type="checkbox"/> engine flooded (do not crank engine with throttle opened, which promotes engine flooding).	
	<input type="checkbox"/> no spark.	
	<input type="checkbox"/> other:	
Engine stalls	<input type="checkbox"/> right after starting.	
	<input type="checkbox"/> when opening throttle grip.	
	<input type="checkbox"/> when closing throttle grip.	
	<input type="checkbox"/> when moving off.	
	<input type="checkbox"/> when stopping the motorcycle.	
	<input type="checkbox"/> when cruising.	
	<input type="checkbox"/> other:	

Troubleshooting the DFI System

Poor running at low speed	<input type="checkbox"/> very low idle speed, <input type="checkbox"/> very high idle speed, <input type="checkbox"/> rough idle speed.
	<input type="checkbox"/> battery voltage is low (charge the battery).
	<input type="checkbox"/> spark plug loose (tighten it).
	<input type="checkbox"/> spark plug dirty, broken, or gap maladjusted (remedy it).
	<input type="checkbox"/> backfiring.
	<input type="checkbox"/> afterfiring.
	<input type="checkbox"/> hesitation when acceleration.
	<input type="checkbox"/> engine oil viscosity too high.
	<input type="checkbox"/> brake dragging.
	<input type="checkbox"/> engine overheating.
	<input type="checkbox"/> clutch slipping.
	<input type="checkbox"/> other:
Poor running or no power at high speed	<input type="checkbox"/> spark plug loose (tighten it).
	<input type="checkbox"/> spark plug dirty, broken, or gap maladjusted (remedy it).
	<input type="checkbox"/> spark plug incorrect (replace it).
	<input type="checkbox"/> knocking (fuel poor quality or incorrect, → use high-octane gasoline).
	<input type="checkbox"/> brake dragging.
	<input type="checkbox"/> clutch slipping.
	<input type="checkbox"/> engine overheating.
	<input type="checkbox"/> engine oil level too high.
	<input type="checkbox"/> engine oil viscosity too high.
<input type="checkbox"/> other:	

3-32 FUEL SYSTEM (DFI)

DFI System Troubleshooting Guide

NOTE

- *This is not an exhaustive list, giving every possible cause for each problem listed. It is meant simply as a rough guide to assist the troubleshooting for some of the more common difficulties in DFI system.*
- *The ECU may be involved in the DFI electrical and ignition system troubles. If these parts and circuits are checked out good, be sure to check the ECU for ground and power supply. If the ground and power supply are checked good, replace the ECU.*

Engine Won't Turn Over

Symptoms or possible Causes	Actions (chapter)
Gear position, starter lockout or sidestand switch trouble	Inspect each switch (see chapter 16).
Immobilizer system trouble	Inspect (see chapter 3).
Vehicle-down sensor coming off	Reinstall (see chapter 3).
Vehicle-down sensor trouble	Inspect (see chapter 3).
Crankshaft sensor trouble	Inspect (see chapter 16).
Stick coil shorted or not in good contact	Inspect or Reinstall (see chapter 16).
Stick coil trouble	Inspect (see chapter 16).
Spark plug dirty, broken or gap maladjusted	Inspect and replace (see chapter 16).
Spark plug incorrect	Replace it with the correct plug (see chapter 2).
ECU ground and power supply trouble	Inspect (see chapter 3).
ECU trouble	Inspect (see chapter 3).
No or little fuel in tank	Supply fuel (see Owner's Manual).
Fuel Injector trouble	Inspect and replace (see chapter 3).
Fuel pump not operating	Inspect (see chapter 3).
Fuel pump relay trouble	Inspect and replace (see chapter 3).
Fuel filter or pump screen clogged	Inspect and replace fuel pump (see chapter 3).
Fuel pressure regulator trouble	Inspect fuel pressure and replace fuel pump (see chapter 16).
Fuel line clogged	Inspect and repair (see chapter 3).

Poor Running at Low Speed

Symptoms or Possible Causes	Actions (chapter)
Spark weak:	
Stick coil shorted or not in good contact	Inspect or Reinstall (see chapter 16).
Stick coil trouble	Inspect (see chapter 16).
Spark plug dirty, broken or gap maladjusted	Inspect and replace (see chapter 16).
Spark plug incorrect	Replace it with the correct plug (see chapter 2).
ECU trouble	Inspect (see chapter 3).
Fuel/air mixture incorrect:	
Little fuel in tank	Supply fuel (see Owner's Manual).
Air cleaner clogged, poorly sealed, or missing	Clean element or inspect sealing (see chapter 3).
Air duct holder loose	Reinstall (see chapter 3).
Throttle body assy holder loose	Reinstall (see chapter 3).
Throttle body assy dust seal damage	Replace (see chapter 3).
Fuel Injector O-ring damage	Replace (see chapter 3).
Fuel filter or pump screen clogged	Inspect and replace fuel pump (see chapter 3).

DFI System Troubleshooting Guide

Symptoms or Possible Causes	Actions (chapter)
Fuel pressure regulator trouble	Inspect fuel pressure and replace fuel pump (see chapter 16).
Fuel line clogged	Inspect and repair (see chapter 3).
Inlet air pressure sensor trouble	Inspect (see chapter 3).
Atmospheric pressure sensor trouble	Inspect (see chapter 3).
Water temperature sensor trouble	Inspect (see chapter 3).
Inlet air temperature sensor trouble	Inspect (see chapter 3).
Main throttle sensor trouble	Inspect (see chapter 3).
Subthrottle sensor trouble	Inspect (see chapter 3).
Subthrottle valve actuator trouble	Inspect (see chapter 3).
Unstable (rough) idling:	
Fuel pressure too low or too high	Inspect (see chapter 3).
Fuel Injector trouble	Inspect (see chapter 3).
Main throttle sensor trouble	Inspect (see chapter 3).
Subthrottle sensor trouble	Inspect (see chapter 3).
Subthrottle valve actuator trouble	Inspect (see chapter 3).
Engine vacuum not synchronizing	Inspect and adjust (see chapter 2).
Inlet air pressure sensor trouble	Inspect (see chapter 3).
Atmospheric pressure sensor trouble	Inspect (see chapter 3).
Water temperature sensor trouble	Inspect (see chapter 3).
Inlet air temperature sensor trouble	Inspect (see chapter 3).
Engine stalls easily:	
Spark plug dirty, broken or gap maladjusted	Inspect and replace (see chapter 16).
Stick coil trouble	Inspect (see chapter 16).
Camshaft position sensor trouble	Inspect (see chapter 16).
Main throttle sensor trouble	Inspect (see chapter 3).
Subthrottle sensor trouble	Inspect (see chapter 3).
Subthrottle valve actuator trouble	Inspect (see chapter 3).
Inlet air pressure sensor trouble	Inspect (see chapter 3).
Atmospheric pressure sensor trouble	Inspect (see chapter 3).
Water temperature sensor trouble	Inspect (see chapter 3).
Inlet air temperature sensor trouble	Inspect (see chapter 3).
Fuel pump trouble	Inspect (see chapter 3).
Fuel Injector trouble	Inspect (see chapter 3).
Fuel pressure too low or too high	Inspect (see chapter 3).
Fuel pressure regulator trouble	Inspect fuel pressure and replace fuel pump (see chapter 16).
Fuel line clogged	Inspect and repair (see chapter 3).
Poor acceleration	
Fuel pressure too low	Inspect (see chapter 3).
Water or foreign matter in fuel	Change fuel. Inspect and clean fuel system (see chapter 3).
Fuel filter or pump screen clogged	Inspect and replace fuel pump (see chapter 3).
Fuel pump trouble	Inspect (see chapter 3).
Fuel Injector trouble	Inspect (see chapter 3).

3-34 FUEL SYSTEM (DFI)

DFI System Troubleshooting Guide

Symptoms or Possible Causes	Actions (chapter)
Main throttle sensor trouble	Inspect (see chapter 3).
Subthrottle sensor trouble	Inspect (see chapter 3).
Subthrottle valve actuator trouble	Inspect (see chapter 3).
Inlet air pressure sensor trouble	Inspect (see chapter 3).
Atmospheric pressure sensor trouble	Inspect (see chapter 3).
Water temperature sensor trouble	Inspect (see chapter 3).
Inlet air temperature sensor trouble	Inspect (see chapter 3).
Spark plug dirty, broken or gap maladjusted	Inspect and replace (see chapter 16).
Stick coil trouble	Inspect (see chapter 16).
Stumble:	
Fuel pressure too low	Inspect (see chapter 3).
Fuel Injector trouble	Inspect (see chapter 3).
Main throttle sensor trouble	Inspect (see chapter 3).
Subthrottle sensor trouble	Inspect (see chapter 3).
Subthrottle valve actuator trouble	Inspect (see chapter 3).
Inlet air pressure sensor trouble	Inspect (see chapter 3).
Atmospheric pressure sensor trouble	Inspect (see chapter 3).
Water temperature sensor trouble	Inspect (see chapter 3).
Inlet air temperature sensor trouble	Inspect (see chapter 3).
Surge:	
Unstable fuel pressure	Fuel pressure regulator trouble (Inspect and replace fuel pump) or kinked fuel line Inspect (Inspect and replace fuel pump) (see chapter 3).
Fuel Injector trouble	Inspect (see chapter 3).
Water temperature sensor trouble	Inspect (see chapter 3).
Backfiring when deceleration:	
Spark plug dirty, broken or gap maladjusted	Inspect and replace (see chapter 16).
Fuel pressure too low	Inspect (see chapter 3).
Fuel pump trouble	Inspect (see chapter 3).
Main throttle sensor trouble	Inspect (see chapter 3).
Subthrottle sensor trouble	Inspect (see chapter 3).
Subthrottle valve actuator trouble	Inspect (see chapter 3).
Inlet air pressure sensor trouble	Inspect (see chapter 3).
Atmospheric pressure sensor trouble	Inspect (see chapter 3).
Water temperature sensor trouble	Inspect (see chapter 3).
Inlet air temperature sensor trouble	Inspect (see chapter 3).
Air switching valve trouble	Inspect and replace (see chapter 16).
Air suction valve trouble	Inspect and replace (see chapter 5).
After fire:	
Spark plug burned or gap maladjusted	Replace (see chapter 16).
Fuel Injector trouble	Inspect (see chapter 3).
Inlet air pressure sensor trouble	Inspect (see chapter 3).
Atmospheric pressure sensor trouble	Inspect (see chapter 3).
Water temperature sensor trouble	Inspect (see chapter 3).

DFI System Troubleshooting Guide

Symptoms or Possible Causes	Actions (chapter)
Inlet air temperature sensor trouble	Inspect (see chapter 3).
Other:	
Intermittent any DFI fault and its recovery	Check that DFI connectors are clean and tight, and examine leads for signs of burning or fraying (see chapter 3).

Poor Running or No Power at High Speed:

Symptoms or Possible Causes	Actions (chapter)
Firing incorrect:	
Stick coil shorted or not in good contact	Inspect or Reinstall (see chapter 16).
Stick coil trouble	Inspect (see chapter 16).
Spark plug dirty, broken or gap maladjusted	Inspect and replace (see chapter 16).
Spark plug incorrect	Replace it with the correct plug (see chapter 2).
ECU trouble	Inspect (see chapter 3).
Fuel/air mixture incorrect:	
Air cleaner clogged, poorly sealed, or missing	Clean element or inspect sealing (see chapter 3).
Air duct holder loose	Reinstall (see chapter 3).
Throttle body assy holder loose	Reinstall (see chapter 3).
Throttle body assy dust seal damage	Replace (see chapter 3).
Water or foreign matter in fuel	Change fuel. Inspect and clean fuel system (see chapter 3).
Fuel Injector O-ring damage	Visually inspect and replace (see chapter 3).
Fuel Injector clogged	Inspect and repair (see chapter 3).
Fuel line clogged	Inspect and repair (see chapter 3).
Fuel pump operates intermittently and often DFI fuse blows.	Fuel Pump bearings may wear. Replace the fuel pump (see chapter 3).
Fuel pump trouble	Inspect (see chapter 3).
Inlet air pressure sensor trouble	Inspect (see chapter 3).
Cracked or obstructed inlet air pressure sensor hose	Inspect and repair or replace (see chapter 3).
Atmospheric pressure sensor trouble	Inspect (see chapter 3).
Water temperature sensor trouble	Inspect (see chapter 3).
Inlet air temperature sensor trouble	Inspect (see chapter 3).
Main throttle sensor trouble	Inspect (see chapter 3).
Subthrottle sensor trouble	Inspect (see chapter 3).
Subthrottle valve actuator trouble	Inspect (see chapter 3).
Knocking:	
Fuel poor quality or incorrect	Fuel change (Use the gasoline recommended in the Owner's Manual).
Spark plug incorrect	Replace it with the correct plug (see chapter 2).
Stick coil trouble	Inspect (see chapter 16).
ECU trouble	Inspect (see chapter 3).
Engine vacuum not synchronizing	Inspect and adjust (see chapter 2).
Inlet air pressure sensor trouble	Inspect (see chapter 3).
Atmospheric pressure sensor trouble	Inspect (see chapter 3).

3-36 FUEL SYSTEM (DFI)

DFI System Troubleshooting Guide

Symptoms or Possible Causes	Actions (chapter)
Water temperature sensor trouble	Inspect (see chapter 3).
Inlet air temperature sensor trouble	Inspect (see chapter 3).
Miscellaneous:	
Subthrottle sensor trouble	Inspect (see chapter 3).
Subthrottle valve actuator trouble	Inspect (see chapter 3).
Speed sensor trouble	Inspect (see chapter 3).
Throttle valves will not fully open	Inspect throttle cables and lever linkage (see chapter 3).
Engine overheating - Water temperature sensor , crankshaft sensor or speed sensor trouble	(see Overheating of Troubleshooting Guide in chapter 17).
Air switching valve trouble	Inspect and replace (see chapter 16).
Air suction valve trouble	Inspect and replace (see chapter 5).
Exhaust Smokes Excessively:	
(White smokes)	
Air cleaner clogged	Clean element (see chapter 3).
Fuel pressure too high	Inspect (see chapter 3).
Fuel Injector trouble	Inspect (see chapter 3).
Water temperature sensor trouble	Inspect (see chapter 3).
Inlet air temperature sensor trouble	Inspect (see chapter 3).
(Brown smoke)	
Air duct holder loose	Reinstall (see chapter 3).
Fuel pressure too low	Inspect (see chapter 3).
Water temperature sensor trouble	Inspect (see chapter 3).
Inlet air temperature sensor trouble	Inspect (see chapter 3).

Self-Diagnosis

Self-diagnosis Outline

The self-diagnosis system has two modes and can be switched to another mode by operating the meter unit.

User Mode

The ECU notifies the rider of troubles in DFI system , ignition system and immobilizer system by lighting up or blinking the warning indicator light (LED) [A] and displaying the warning message [B] and warning symbol [C] alternately on the LCD (Liquid Crystal Display) when DFI, ignition and immobilizer system parts are faulty, and initiates fail-safe function. In case of serious troubles ECU stops the injection/ignition/starter motor operation.

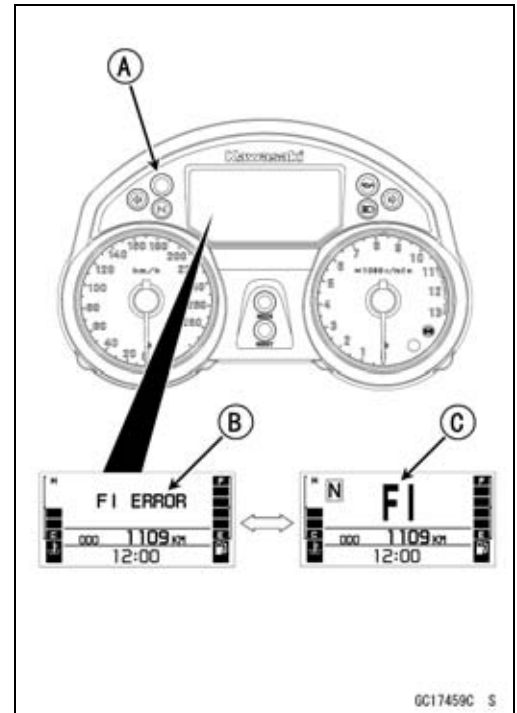

Dealer Mode

The LCD (Liquid Crystal Display) display the service code(s) [A] to show the problem(s) which the DFI system, ignition system and immobilizer system has at the moment of diagnosis.

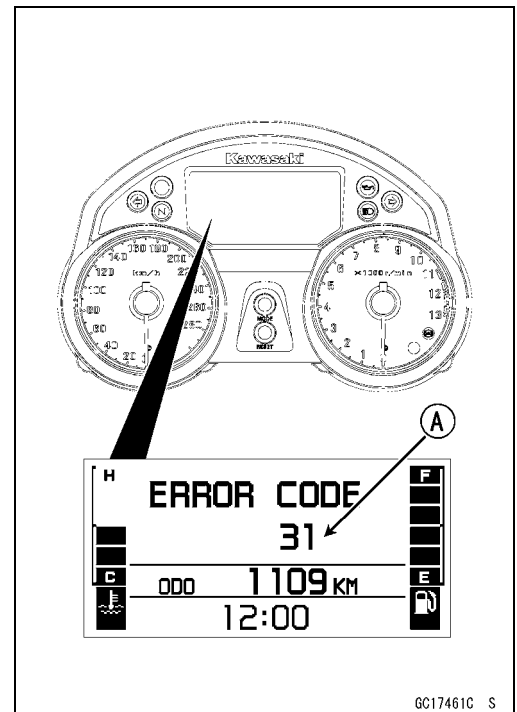

3-38 FUEL SYSTEM (DFI)

Self-Diagnosis

Self-diagnosis Procedures

○When a problem occurs with DFI system and ignition system, the warning indicator (LED) [A] goes on and FI warning message [B] and FI warning symbol [C] are displayed alternately on the LCD (Liquid Crystal Display) to alert the rider.

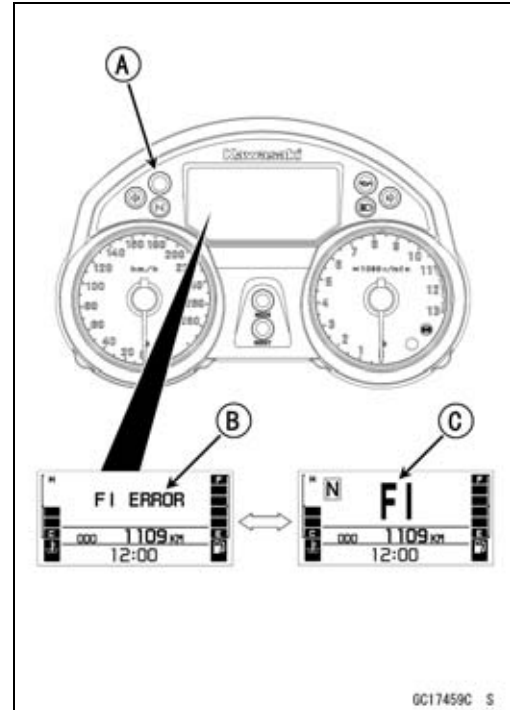

○For models equipped with an immobilizer system, the warning indicator light (LED) [A] blinks and immobilizer warning message [B] and immobilizer warning symbol [C] are alternately displayed on the LCD, when a problem occurs in the system.

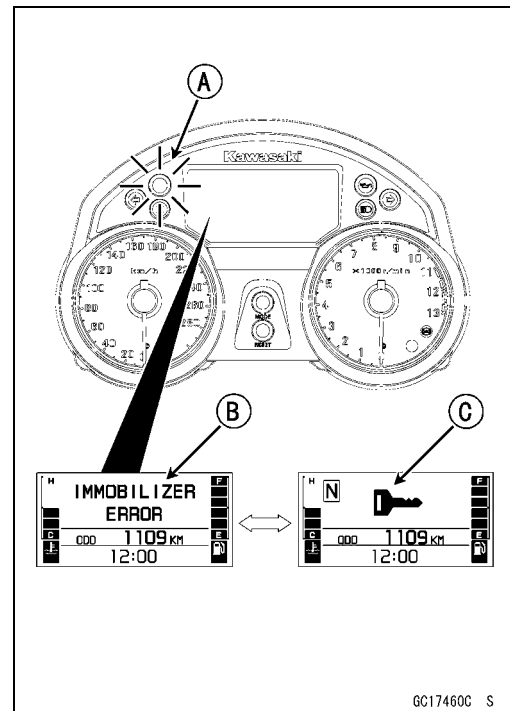

Self-Diagnosis

- Turn the ignition switch ON.
 - Push the MODE button [A] and RESET button [B] for more than two seconds.
 - The service code [C] is displayed on the LCD by the number of two digits.
- When pushing and holding the MODE button while the warning message and warning symbol are displayed alternately on the LCD, the display on the LCD is shifted to the previous display with the warning indicator light (LED) goes on.
- After switching to the previous display, the service code can not be displayed even if pushing the MODE button and RESET button for more than two seconds.

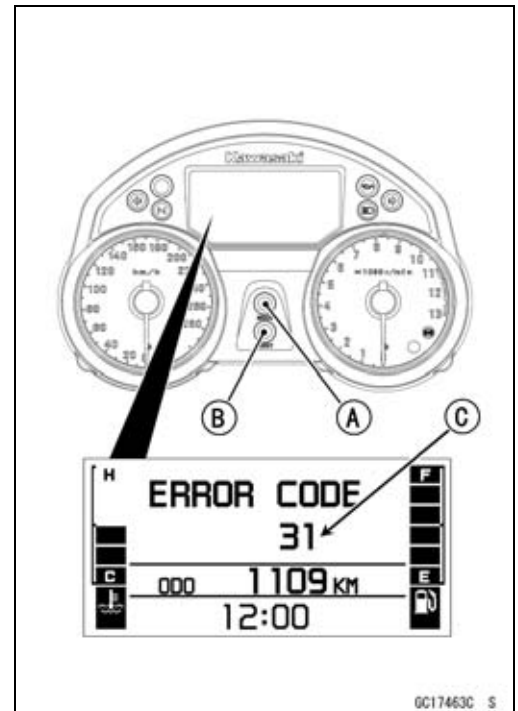

- Any of the following procedures ends self-diagnosis.
- When the service code is displayed on the LCD, push the MODE button and RESET button for more than two seconds.
- When the ignition switch is turned OFF.

3-40 FUEL SYSTEM (DFI)

Self-Diagnosis

Self-Diagnosis Flow Chart

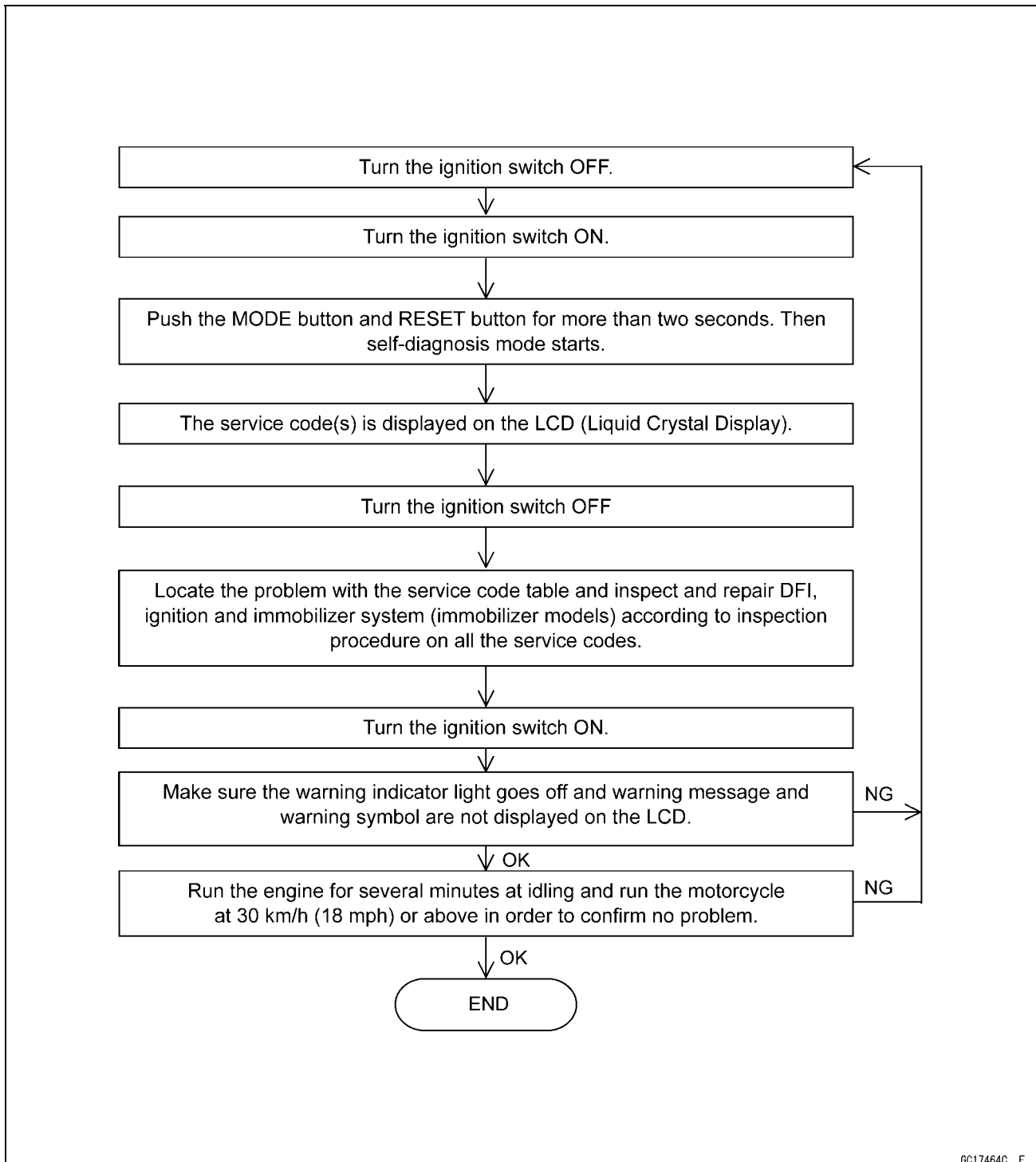

Self-Diagnosis

Service Code Reading

- The service code(s) is displayed on the LCD by the number of two digits.
- When there are a number of problems, all the service codes can be stored and the display will begin starting from the lowest number service code in the numerical order.
- Then after completing all codes, the display is repeated until the ignition switch is turned OFF or MODE button and RESET button are pushed for more than two seconds.
- For example, if three problems occurred in the order of 46, 15, 35, the service codes are displayed (each two seconds) from the lowest number in the order listed as shown below. (15→35→46)→(15→35→46)→ . . .(repeated)

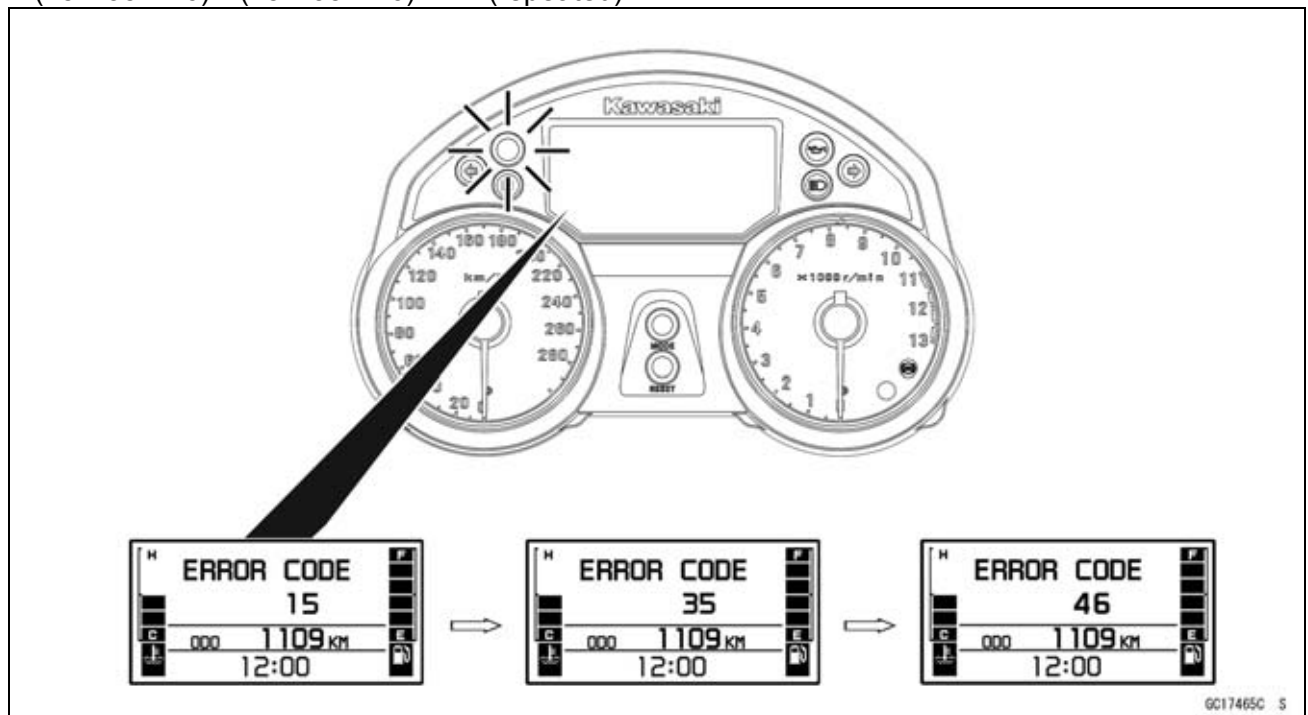

- In the case more than two service codes are available, you may push the MODE button to shift into the other code too.
- If the no problem or when the repair has done, warning indicator light (LED) goes off and warning message and warning symbol are not displayed, and no service code is displayed.
- If the problem is with the following parts, the ECU can not memorize these problem, he warning indicator light (LED) do not lights up or blinks and warning message and warning symbol are not displayed, and no service codes can be displayed.
 - Warning Indicator Light (LED)
 - Meter Panel LCD
 - Stick Coil Secondary Wiring and Ground Wiring (see Stick Coil (Ignition Coil together with Spark Plug Cap) Inspection in the Electrical System chapter)
 - ECU Power Source Wiring and Ground Wiring (see ECU power Supply Inspection)

Service Code Erasing

- When repair has been done, warning indicator light (LED) goes off and warning message and warning symbol are not displayed, and no service code is displayed.
- ★But the service codes stored in memory of the ECU are not erased to preserve the problem history. In this model, the problem history can not be erased.

3-42 FUEL SYSTEM (DFI)

Self-Diagnosis

Service Code Table

Service Code	Problems
11	Main throttle sensor malfunction, wiring open or short
12	Inlet air pressure sensor malfunction, wiring open or short
13	Inlet air temperature sensor malfunction, wiring open or short
14	Water temperature sensor malfunction, wiring open or short
15	Atmospheric pressure sensor malfunction, wiring open or short
21	Crankshaft sensor malfunction, wiring open or short
23	Camshaft position sensor malfunction, wiring open or short
24	Speed sensor malfunction
25	Gear position switch malfunction, wiring open or short
31	Vehicle-down sensor malfunction, wiring open or short
32	Subthrottle sensor malfunction, wiring open or short
35	Immobilizer amplifier malfunction
36	Blank key detection
46	Fuel pump relay malfunction, relay is stuck
51	Stick (Ignition) coil #1 malfunction, wiring open or short
52	Stick (Ignition) coil #2 malfunction, wiring open or short
53	Stick (Ignition) coil #3 malfunction, wiring open or short
54	Stick (Ignition) coil #4 malfunction, wiring open or short
62	Subthrottle valve actuator malfunction, wiring open or short
75	ECU main relay malfunction, relay is stuck

Notes:

- The ECU may be involved in these problems. If all the parts and circuits checked out good, be sure to check the ECU for ground and power supply. If the ground and power supply are checked good, replace the ECU.
- When no service code is displayed, the electrical parts of the DFI system has no fault, and the mechanical parts of the DFI system and the engine are suspect.

Self-Diagnosis

Backups

○The ECU takes the following measures to prevent engine damage when the DFI, ignition or immobilizer system parts have troubles.

Service Codes	Parts	Output Signal Usable Range or Criteria	Backups by ECU
11	Main Throttle Sensor	Main Throttle Sensor Output Voltage 0.2 ~ 4.8 V	If the main throttle sensor system fails (the signal is out of the usable range, wiring short or open), the ECU locks ignition timing into the ignition timing at closed throttle position and sets the DFI in the D-J method.
12	Inlet Air Pressure Sensor	Inlet Air Pressure (absolute) Pv = 100 mmHg ~ 900 mmHg	If the inlet air pressure sensor system fails (the signal Pv is out of the usable range, wiring short or open), the ECU sets the DFI in the α-N method (1).
13	Inlet Air Temperature Sensor	Inlet Air Temperature Ta = - 30°C ~ + 100°C	If the inlet air temperature sensor fails (the signal is out of the usable range, wiring short or open), the ECU sets Ta at 30°C.
14	Water Temperature Sensor	Water Temperature Tw = - 30°C ~ + 120°C	If the water temperature sensor system fails (the signal is out of the usable range, wiring short or open), the ECU sets Tw at 80°C.
15	Atmospheric Pressure Sensor	Absolute Atmospheric Pressure Pa = 100 mmHg ~ 900 mmHg	If the atmospheric pressure sensor system fails (the signal is out of the usable range, wiring short or open), the ECU sets Pa at 760 mmHg (the standard atmospheric pressure).
21	Crankshaft Sensor	Crankshaft sensor cannot send the signal to the ECU during 8 crankings.	If crankshaft sensor fails, the engine stops by itself.
23	Camshaft Position Sensor	Camshaft position sensor cannot send the signal to the ECU during 24 crankings.	If the camshaft position sensor system fails (the signal is missing, wiring short or open), the ECU continues to ignite cylinders in the same sequence following the last good signal.
24	Speed Sensor	Speed sensor must send 4 signals (output signal) to the ECU at the one rotation of the drive shaft.	If the speed sensor system fails (no signal, wiring short or open), the speedometer shows 0.
25	Gear Position Switch	Gear Position Switch Output Voltage (signal) Vg = 0.2 ~ 4.8 V	If the speed sensor system fails (no signal, wiring short or open), the ECU set the top (6) gear position.
31	Vehicle-down Sensor	Vehicle-down Sensor Output Voltage (signal) Vd = 0.2 ~ 4.8 V	If the vehicle-down sensor system has failures (the output voltage Vd is more than usable range, wiring open), the ECU shuts off the fuel pump, the fuel injectors and the ignition system.
32	Subthrottle Sensor	Subthrottle Sensor Output Voltage 0.2 ~ 4.8 V	If the subthrottle sensor system fails (the signal is out of the usable range, wiring short or open), the actuator locks subthrottle valve at full open position.
35	Immobilizer Amplifier	-	If the immobilizer system fails (no signal, wiring short or open), the vehicle is no start and run.
36	Master or User Key	The user or master key must use register key.	If the blank key or broken key is used, the vehicle is no start and run.

3-44 FUEL SYSTEM (DFI)

Self-Diagnosis

Service Codes	Parts	Output Signal Usable Range or Criteria	Backups by ECU
46	Fuel Pump Relay	When the relay ON condition, battery monitor voltage 5 V or more	If the relay fails, battery monitor voltage 12 V.
51	Stick Coil #1 (Ignition Coil)*	The ignition coil primary winding must send signals (output voltage) 32 or more times continuously to the ECU.	If the ignition primary winding #1 has failures (no signal, wiring short or open), the ECU shuts off the injector #1 to stop fuel to the cylinder #1, though the engine keeps running.
52	Stick Coil #2 (Ignition Coil)*	The ignition coil primary winding must send signals (output voltage) 32 or more times continuously to the ECU.	If the ignition primary winding #2 has failures (no signal, wiring short or open), the ECU shuts off the injector #2 to stop fuel to the cylinder #2, though the engine keeps running.
53	Stick Coil #3 (Ignition Coil)*	The ignition coil primary winding must send signals (output voltage) 32 or more times continuously to the ECU.	If the ignition primary winding #3 has failures (no signal, wiring short or open), the ECU shuts off the injector #3 to stop fuel to the cylinder #3, though the engine keeps running.
54	Stick Coil #4 (Ignition Coil)*	The ignition coil primary winding must send signals (output voltage) 32 or more times continuously to the ECU.	If the ignition primary winding #4 has failures (no signal, wiring short or open), the ECU shuts off the injector #4 to stop fuel to the cylinder #4, though the engine keeps running.
62	Subthrottle Valve Actuator	The actuator operates open and close of the subthrottle valve by the pulse signal from the ECU.	If the subthrottle valve actuator fails (the signal is out to the usable range, wiring short or open), the ECU stops the current to the actuator.
75	ECU Main Relay	When the relay OFF condition, the main relay is open.	–

Note:

(1) α -N Method: the DFI control method from medium to heavy engine load. When the engine load is light like at idling or low speed, the ECU determines the injection quantity by calculating from the throttle vacuum (vacuum sensor output voltage) and engine speed (crankshaft sensor output voltage). This method is called D-J method. As the engine speed increases, and the engine load turns middle to heavy, the ECU determines the injection quantity by calculating from the throttle opening (throttle sensor output voltage) and the engine speed. This method is called α -N method.

* This depends on the number of stopped cylinders.

Main Throttle Sensor (Service Code 11)

The main throttle sensor is a rotating variable resistor that change output voltage according to throttle operating. The ECU senses this voltage change and determines fuel injection quantity, and ignition timing according to engine rpm, and throttle opening.

Input Terminal [A]

Output Terminal [B]

Ground Terminal [C]

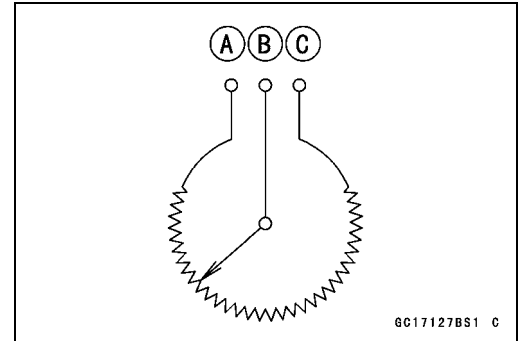

Main Throttle Sensor Removal/Adjustment

CAUTION

Do not remove or adjust the main throttle sensor [A] since it has been adjusted and set with precision at the factory.

Never drop the throttle body assy, especially on a hard surface. Such a shock to the sensor can damage it.



Input Voltage Inspection

NOTE

○Be sure the battery is fully charged.

- Turn the ignition switch OFF.
- Remove the ECU (see ECU Removal).
- Do not disconnect the ECU connectors.
- Connect a digital meter [A] to the connectors [B], using the needle adapter set.

Special Tool - Needle Adapter Set: 57001-1457

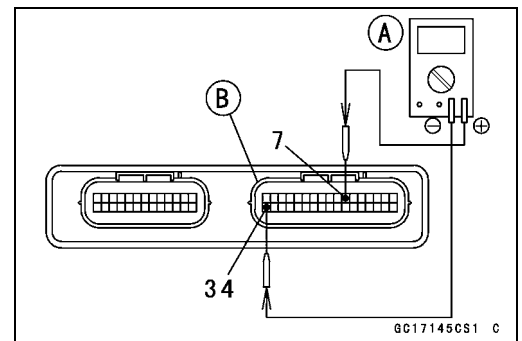

Main Throttle Sensor Input Voltage

Connections to ECU Connector

Meter (+) → BL lead (terminal 7)

Meter (-) → BR/BK lead (terminal 34)

- Measure the input voltage with the engine stopped, and with the connectors joined.
- Turn the ignition switch ON.

Input Voltage at ECU Connector

Standard: DC 4.75 ~ 5.25 V

- Turn the ignition switch OFF.
- ★ If the reading of input voltage is less than the standard, check the ECU for its ground, and power supply (see ECU Power Supply Inspection) and wiring shorted.
- ★ If the input voltage is within the standard range, check the input voltage at the main throttle sensor connector.

3-46 FUEL SYSTEM (DFI)

Main Throttle Sensor (Service Code 11)

- Remove the right fairing cover (see Fairing Cover Removal in the Frame chapter).
- Disconnect the main throttle sensor connector [A].



- Connect the harness adapter [A] between the harness connector and main throttle sensor connector.

Special Tool - Throttle Sensor Setting Adapter: 57001-1538

- Connect a digital meter to the harness adapter leads.

Main Throttle Sensor Input Voltage Connections to Adapter

Meter (+) → W (sensor BL) lead

Meter (-) → BK (sensor BR/BK) lead

- Measure the input voltage with the engine stopped, and with the connector joined.
- Turn the ignition switch ON.

Input Voltage at Sensor

Standard: DC 4.75 ~ 5.25 V

- Turn the ignition switch OFF.
- ★ If the reading is out of the range, check the wiring (see wiring diagram in this section).
- ★ If the reading is good, check the output voltage of the sensor.



Main Throttle Sensor (Service Code 11)

Output Voltage Inspection

- Measure the output voltage at the ECU in the same way as input voltage inspection. Note the following.

Digital Meter [A]

Connector [B]

Special Tool - Needle Adapter Set: 57001-1457

Main Throttle Sensor Output Voltage

Connections to ECU Connector

Meter (+) → Y/W lead (terminal 26)

Meter (-) → BR/BK lead (terminal 34)

- Start the engine and warm it up thoroughly.
- Check idle speed to ensure throttle opening is correct.

Idle Speed

Standard: 1 100 r/min (rpm)

- ★ If the idle speed is out of the specified range, adjust the idle speed (see Idle Speed Inspection in Periodic Maintenance chapter).

- Turn the ignition switch OFF.
- Measure the output voltage with the engine stopped, and with the connector joined.
- Turn the ignition switch ON.
- Measure the output voltage when the throttle is fully opened or completely closed.

Output Voltage at ECU

Standard: DC 0.63 ~ 3.91 V (at idle throttle opening to full throttle opening)

NOTE

- *The throttle sensor is operating correctly if the following voltages are obtained:*
 - DC 0.63 V (or slightly higher) with the throttle at the idle position.
 - DC 3.91 V (or slightly lower) with the throttle at the fully open position.

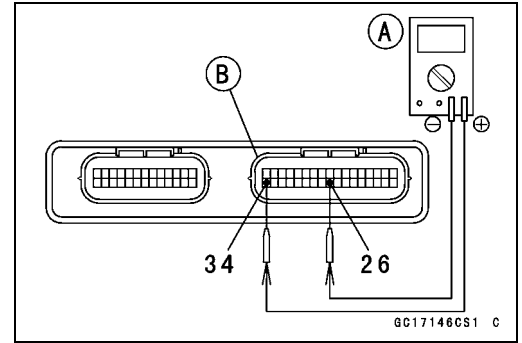

CAUTION

Do not remove or adjust the main throttle sensor. It has been adjusted and set with precision at the factory.

Never drop the sensor can especially on a hard surface. A shock to the sensor can damage it.

3-48 FUEL SYSTEM (DFI)

Main Throttle Sensor (Service Code 11)

NOTE

○The standard voltage refers to the value when the voltage reading at the Input Voltage Inspection shows 5V exactly.

○When the input voltage reading shows other than 5V, derive a voltage range as follows.

Example:

In the case of a input voltage of 4.75 V.

$$0.63 \times 4.75 \div 5.00 = 0.60 \text{ V}$$

$$3.91 \times 4.75 \div 5.00 = 3.71 \text{ V}$$

Thus, the valid range is 0.60 ~ 3.71 V

- ★If the output voltage is within the standard range, check the ECU for its ground, and power supply (see ECU Power Supply Inspection).
- ★If the ground and power supply are good, replace the ECU (see ECU section).
- ★If the output voltage is far out of the standard range (e.g. when the wiring is open, the reading is 0 V), check the output voltage again at the sensor connector.

Main Throttle Sensor (Service Code 11)

- Disconnect the main throttle sensor connector and connect the harness adapter [A] between the harness connector and main throttle sensor connector.

Special Tool - Throttle Sensor Setting Adapter: 57001-1538

- Connect a digital meter to the harness adapter leads.

Throttle Sensor Output Voltage Connections to Adapter

Meter (+) → R (sensor Y/W) lead

Meter (-) → BK (sensor BR/BK) lead

- Measure the sensor output voltage with the engine stopped, and with the connector joined.
- Turn the ignition switch ON.
- Measure the output voltage when the throttle is fully opened or completely closed.

Output Voltage at Sensor

Standard: DC 0.63 ~ 3.91 V (at idle throttle opening to full throttle opening)

NOTE

- *The throttle sensor is operating correctly if the following voltages are obtained:*
 - DC 0.63 V (or slightly higher) with the throttle at the idle position.
 - DC 3.91 V (or slightly lower) with the throttle at the fully open position.

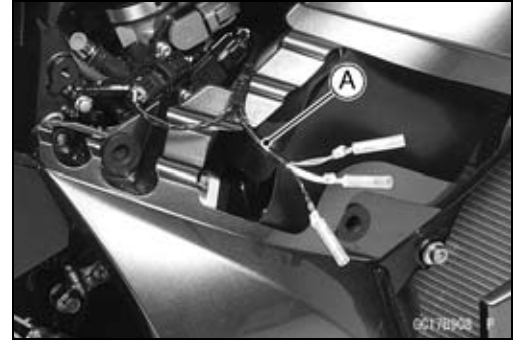

CAUTION

**Do not remove or adjust the main throttle sensor. It has been adjusted and set with precision at the factory.
Never drop the sensor, especially on a hard surface. A shock to the sensor can damage it.**

NOTE

- *The standard voltage refers to the value when the voltage reading at the Input Voltage Inspection shows 5V exactly.*
- *When the input voltage reading shows other than 5V, derive a voltage range as follows.*
Example:
In the case of a input voltage of 4.75 V.
 $0.63 \times 4.75 \div 5.00 = 0.60 \text{ V}$
 $3.91 \times 4.75 \div 5.00 = 3.71 \text{ V}$
Thus, the valid range is 0.60 ~ 3.71 V
- Turn the ignition switch OFF.
- ★ If the reading is out of the standard range, inspect the main throttle sensor resistance.
- ★ If the output voltage is normal, check the wiring for continuity (see wiring diagram in this section).

3-50 FUEL SYSTEM (DFI)

Main Throttle Sensor (Service Code 11)

Resistance Inspection

- Turn the ignition switch OFF.
- Disconnect the main throttle sensor connector.
- Connect a digital meter [A] to the main throttle sensor connector [B].
- Measure the main throttle sensor resistance.

Main Throttle Sensor Resistance

Connections: BL lead [C] ↔ BR/BK lead [D]

Standard: 4 ~ 6 kΩ

- ★ If the reading is out of the range, replace the throttle body assy (see Throttle Body Assy section).
- ★ If the reading is within the range, but the problem still exists, replace the ECU (see ECU section).

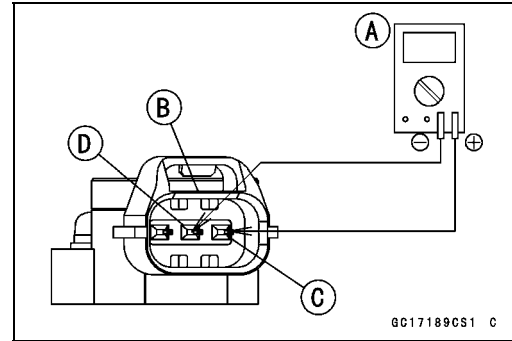

Main Throttle Sensor Circuit

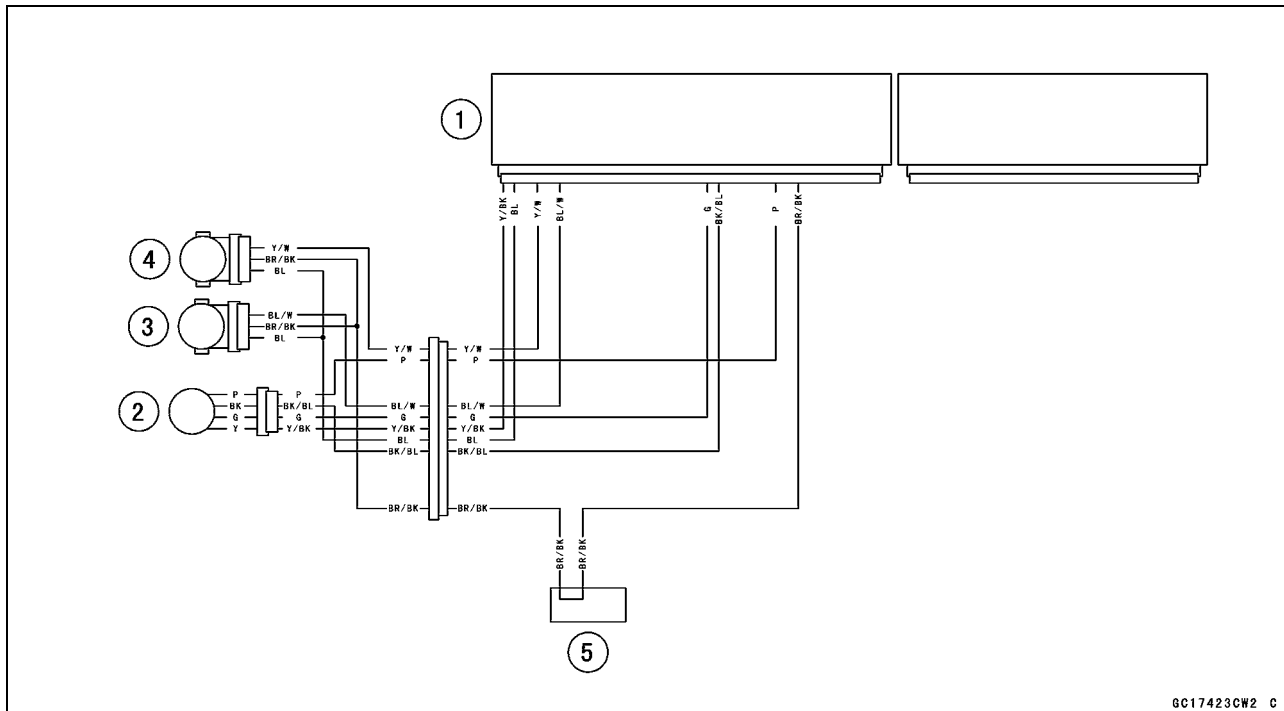

1. ECU
2. Subthrottle Valve Actuator
3. Subthrottle Sensor
4. Main Throttle Sensor
5. Water-proof Joint 2

Inlet Air Pressure Sensor (Service Code 12)

CAUTION

Never drop the sensor, especially on a hard surface. Such a shock to the part can damage it.

Removal

- Remove:
 - Fuel Tank Cover (see Fuel Tank Removal)
 - Bolt [A]
 - Bracket [B]

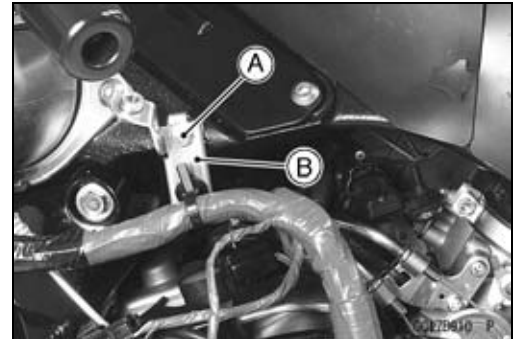

- Remove:
 - Inlet Air Pressure Sensor Connector [A]
 - Inlet Air Pressure Sensor [B]
 - Vacuum Hose [C]

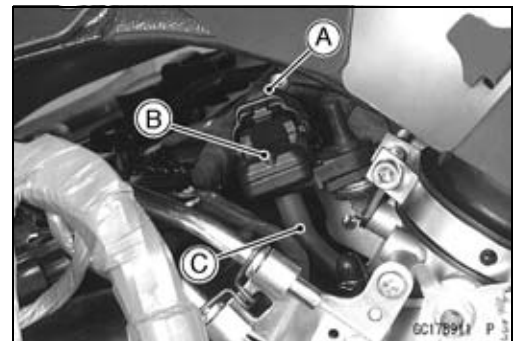

Installation

NOTE

○The inlet air pressure sensor is the same part as the atmospheric sensor except that the sensor has a vacuum hose and different wiring.

- Install the vacuum hose.
- Put the inlet air pressure sensor in the stay plate [A] of throttle body assy.



3-52 FUEL SYSTEM (DFI)

Inlet Air Pressure Sensor (Service Code 12)

Input Voltage Inspection

NOTE

- Be sure the battery is fully charged.
- The inspection is the same as "Input Voltage Inspection" of the throttle sensor and the atmospheric pressure sensor.
- Turn the ignition switch OFF.
- Remove the ECU (see ECU Removal).
- Do not disconnect the ECU connectors.
- Connect a digital meter [A] to the connector [B], with the needle adapter set.

Special Tool - Needle Adapter Set: 57001-1457

Inlet Air Pressure Sensor Input Voltage Connections to ECU Connector

Meter (+) → BL lead (terminal 7)

Meter (-) → BR/BK lead (terminal 34)

- Measure the input voltage with the engine stopped, and with the connectors joined.
- Turn the ignition switch ON.

Input Voltage at ECU

Standard: DC 4.75 ~ 5.25 V

- ★ If the reading is less than the standard range, check the ECU for its ground, and power supply (see ECU Power Supply Inspection).
- ★ If the ground and power supply are good, replace the ECU (see ECU section).
- ★ If the reading is within the standard range, and check the input voltage again at the sensor connector.

- Disconnect the inlet air pressure sensor connector and connect the harness adapter [A] between the harness connector and inlet air pressure sensor connector.

Special Tool - Sensor Harness Adapter: 57001-1561

- Connect a digital meter to the harness adapter leads. Inlet Air Pressure Sensor [B]

Inlet Air Pressure Sensor Input Voltage Connections to Adapter

Meter (+) → G (sensor BL) lead [C]

Meter (-) → BK (sensor BR/BK) lead [D]

- Measure the input voltage with the engine stopped, and with the connector joined.
- Turn the ignition switch ON.

Input Voltage at Sensor Connector

Standard: DC 4.75 ~ 5.25 V

- Turn the ignition switch OFF.
- ★ If the reading is out of the standard range, check the wiring (see wiring diagram in this section).
- ★ If the reading is good, the input voltage is normal. Check the output voltage.

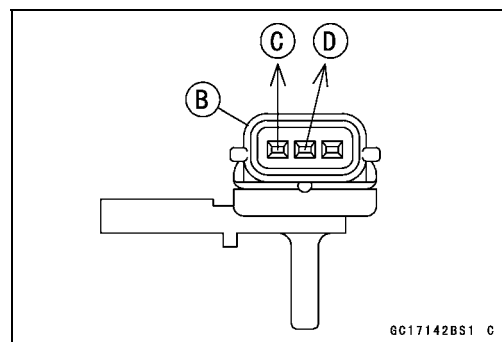
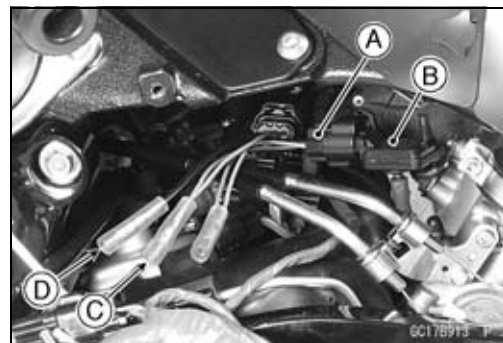
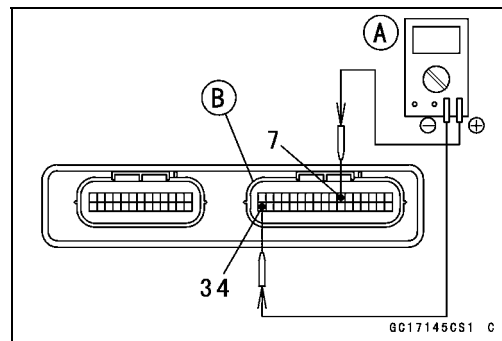

Inlet Air Pressure Sensor (Service Code 12)

Output Voltage Inspection

- Measure the output voltage at the ECU in the same way as input voltage inspection. Note the following.

Digital Meter [A]

Connector [B]

Special Tool - Needle Adapter Set: 57001-1457

Inlet Air Pressure Sensor Output Voltage Connections to ECU

Meter (+) → Y/BL lead (terminal 28)

Meter (-) → BR/BK lead (terminal 34)

Output Voltage at ECU

Usable Range: DC 3.80 ~ 4.20 V at the standard atmospheric pressure (101.32 kPa, 76 cmHg abs.)

NOTE

- The output voltage changes according to the local atmospheric pressure.
- The vacuum sensor output voltage is based on a nearly perfect vacuum in the small chamber of the sensor. So, the sensor indicates absolute vacuum pressure.
- ★ If the output voltage is within the usable range, check the ECU for its ground, and power supply (see ECU Power Supply Inspection).
- ★ If the ground and power supply are good, replace the ECU (see ECU section).
- ★ If the output voltage is far out of the usable range, check the output voltage again at the sensor connector [A] (when the lead is open, the output voltage is about 1.8 V).

- Connect a digital meter to the harness adapter leads. Inlet Air Pressure Sensor [B]

Special Tool - Sensor Harness Adapter: 57001-1561

Inlet Air Pressure Sensor Output Voltage Connections to Adapter

Meter (+) → G/W (sensor Y/BL) lead [C]

Meter (-) → BK (sensor BR/BK) lead [D]

- ★ Measure the input voltage with the engine stopped, and with the connector joined.
- ★ Turn the ignition switch ON.

Output Voltage at Sensor Connector

Usable Range: DC 3.80 ~ 4.20 V at the standard atmospheric pressure (101.32 kPa or 76 cmHg abs.)

- Turn the ignition switch OFF.
- ★ If the output voltage is normal, check the wiring for continuity (see wiring diagram in this section).
- ★ If the output voltage is out of the usable range, replace the sensor.

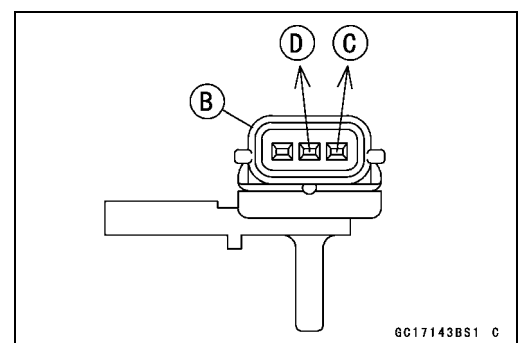
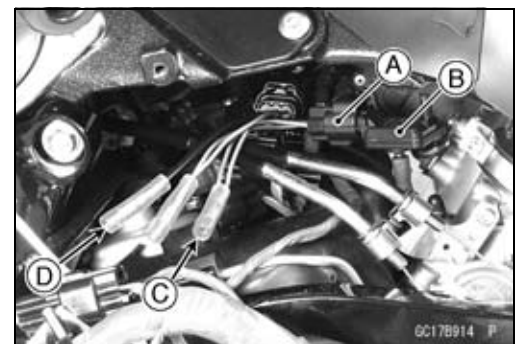
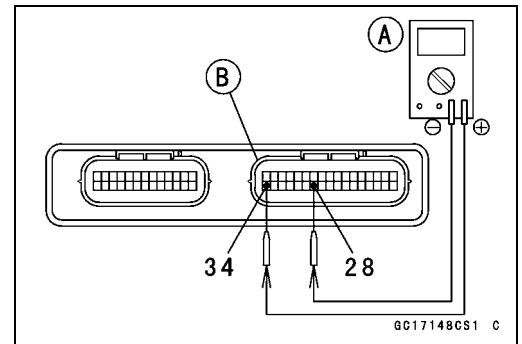

Inlet Air Pressure Sensor (Service Code 12)

- Remove the inlet air pressure sensor [A] and disconnect the vacuum hose from the sensor.
- Connect an auxiliary hose [B] to the inlet air pressure sensor.
- Temporarily install the inlet air pressure sensor.
- Connect a digital meter [C], vacuum gauge [D], and the fork oil level gauge [E] to the inlet air pressure sensor.

Special Tools - Fork Oil Level Gauge: 57001-1290
Vacuum Gauge: 57001-1369
Sensor Harness Adapter: 57001-1561

Inlet Air Pressure Sensor Output Voltage Connection to Adapter

Meter (+) → G/W (sensor Y/BL) lead

Meter (-) → BK (sensor BR/BK) lead

- Turn the ignition switch ON.
- Measure the inlet air pressure sensor output voltage from various vacuum readings, while pulling the handle of the fork oil level gauge.
- Check the inlet air pressure sensor output voltage, using the following formula and chart.

Suppose:

- Pg : Vacuum Pressure (gauge) of Throttle Assy
- PI : Local Atmospheric Pressure (abs.) measured by a barometer
- Pv : Vacuum Pressure (abs.) of Throttle Assy
- Vv : Sensor Output Voltage (v)

then

$$Pv = PI - Pg$$

For example, suppose the following data is obtained:

- Pg = 8 cmHg (vacuum gauge reading)
- PI = 70 cmHg (barometer reading)
- Vv = 3.2 V (digital volt meter reading)

then

$$Pv = 70 - 8 = 62 \text{ cmHg (abs.)}$$

Plot this Pv (62 cmHg) at a point [1] on the chart and draw a vertical line through the point. Then, you can get the usable range [2] of the sensor output voltage.

Usable range = 3.08 ~ 3.48 V

Plot Vv (3.2 V) on the vertical line. → Point [3].

Results: In the chart, Vv is within the usable range and the sensor is normal.

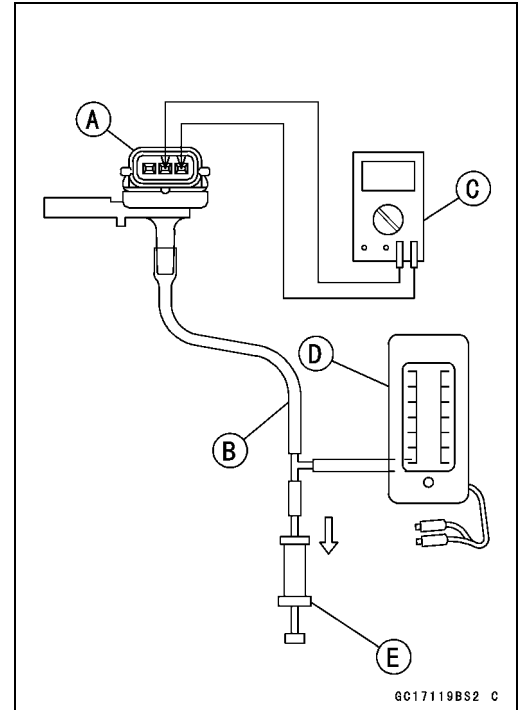

GC17119BS2 C

3-56 FUEL SYSTEM (DFI)

Inlet Air Pressure Sensor (Service Code 12)

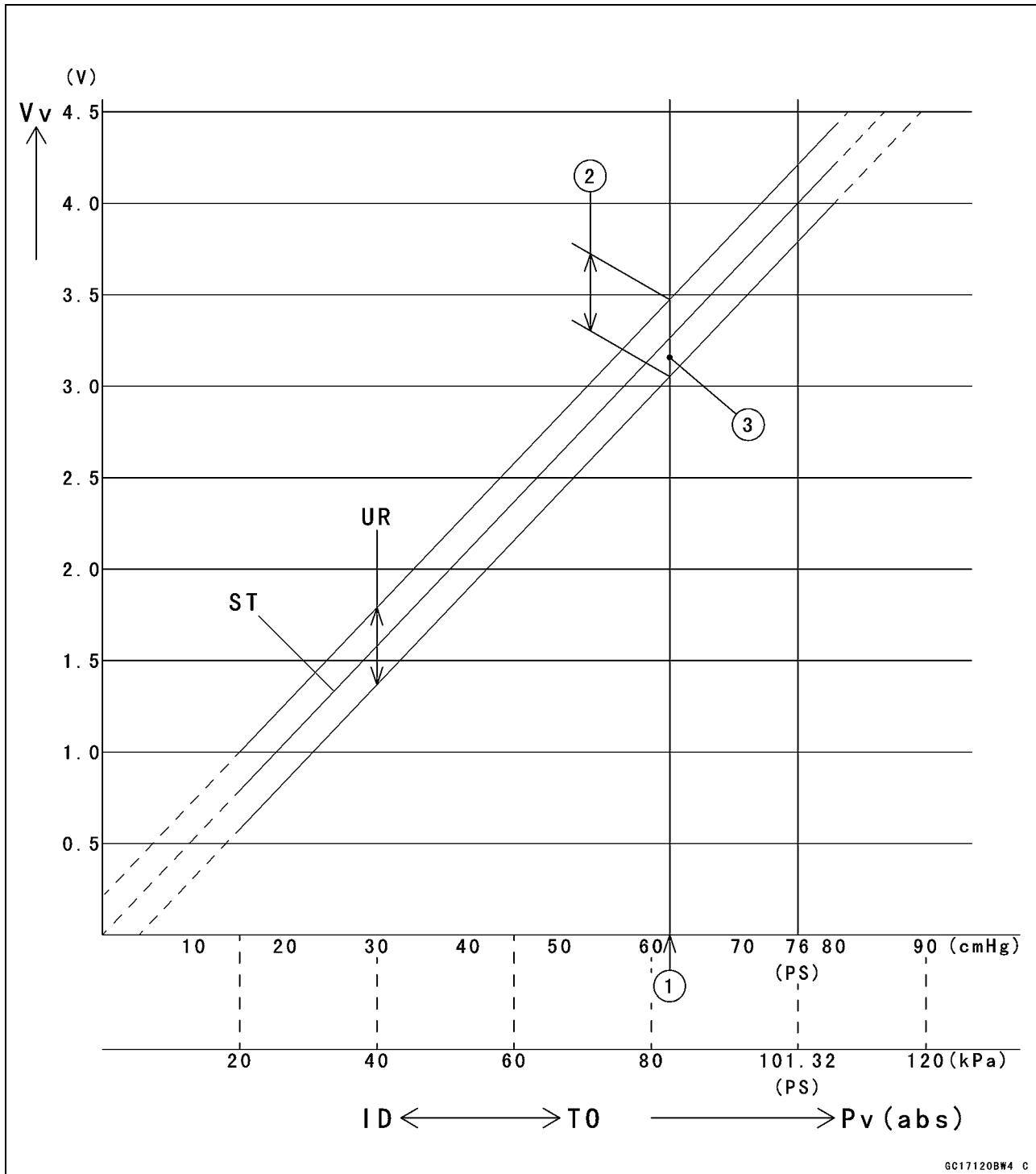

GC17120BW4 C

- ID: Idling
- Pv: Throttle Vacuum Pressure (abs.)
- Ps: Standard Atmospheric Pressure (abs.)
- ST: Standard of Sensor Output Voltage (v)
- TO: Throttle Full Open
- UR: Usable Range of Sensor Output Voltage (v)
- Vv: Inlet Air Pressure Sensor Output Voltage (V) (Digital Meter Reading)

Inlet Air Temperature Sensor (Service Code 13)

Removal/Installation

CAUTION
Never drop the sensor, especially on a hard surface. Such a shock to the sensor can damage it.

- Remove the fuel tank (see Fuel Tank Removal).
- Open the clamp [A]
- Disconnect the connector [B] from the inlet air temperature sensor.
- Pull out the inlet air temperature sensor [C].
- Install the inlet air temperature sensor [A] in the grommet [B].

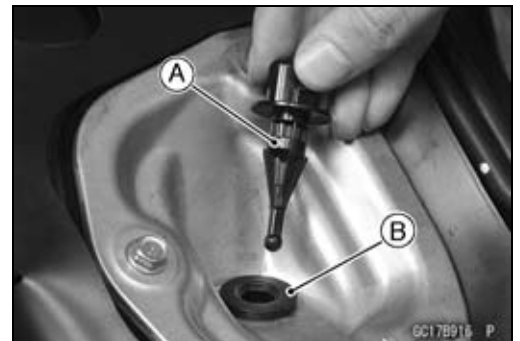
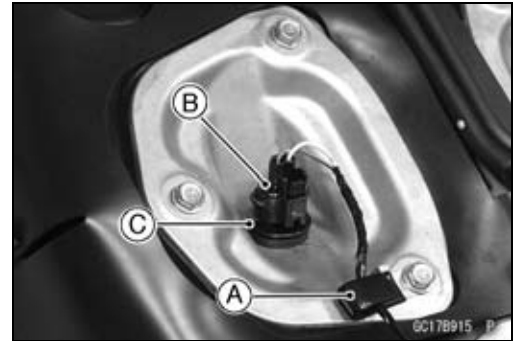

Output Voltage Inspection

NOTE

○Be sure the battery is fully charged.

- Remove the ECU (see ECU Removal).
- Do not disconnect the ECU connectors.
- Connect a digital meter to the ECU connector, using needle adapter set.

Special Tool - Needle Adapter Set: 57001-1457

Inlet Air Temperature Sensor Output Voltage Connections to ECU Connector

Meter (+) → Y lead (terminal 8)

Meter (-) → BR/BK lead (terminal 34)

- Measure the sensor output voltage with the engine stopped and the connector joined.
- Turn the ignition switch ON.

Output Voltage at ECU

Standard: About 2.25 ~ 2.50 V at inlet air temperature 20°C (68°F)

NOTE

○The output voltage changes according to the inlet air temperature.

- Turn the ignition switch OFF.

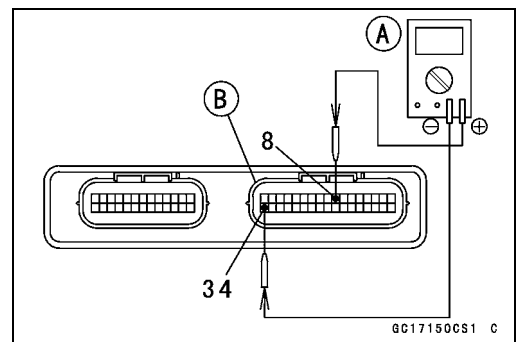

3-58 FUEL SYSTEM (DFI)

Inlet Air Temperature Sensor (Service Code 13)

- ★ If the output voltage is out of the specified, check the ECU for its ground, and power supply (see ECU Power Supply Inspection).
- ★ If the ground and power supply are good, replace the ECU (see ECU section).
- ★ If the output voltage is far out of the specified (e.g. when the wiring is open, the voltage is about 4.6 V), check the wiring (see wiring diagram in this section).
- ★ If the wiring is good, check the sensor resistance.

Sensor Resistance Inspection

- Remove the inlet air temperature sensor (see Removal/Installation).
- Suspend the sensor [A] in a container of machine oil so that the heat-sensitive portion is submerged.
- Suspend a thermometer [B] with the heat-sensitive portion [C] located in almost the same depth with the sensor.

NOTE

- *The sensor and thermometer must not touch the container side or bottom.*
- Place the container over a source of heat and gradually raise the temperature of the oil while stirring the oil gently for even temperature.
- Using a digital meter, measure the internal resistance of the sensor across the terminals at the temperatures shown in the table.

Inlet Air Temperature Sensor Resistance

Standard: 2.09 ~ 2.81 k Ω at 20°C (68°F)

About 0.322 k Ω at 80°C (176°F) (reference value)

- ★ If the measurement is out of the range, replace the sensor.
- ★ If the measurement is within the specified, replace the ECU (see ECU section).

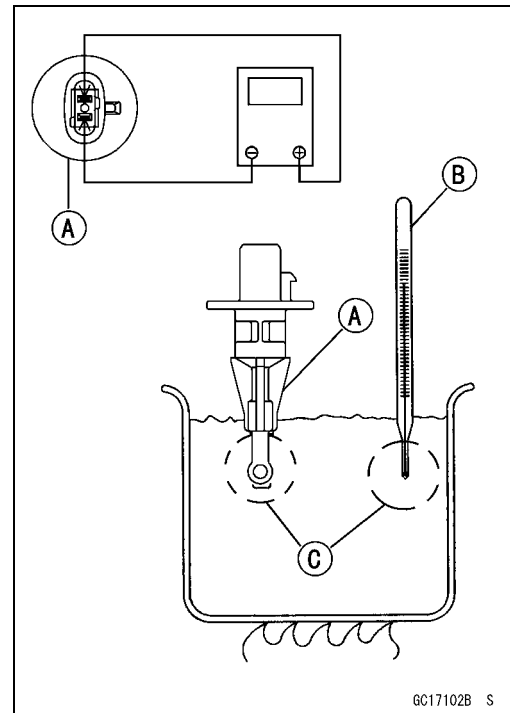

Inlet Air Temperature Sensor (Service Code 13)

Inlet Air Temperature Sensor Circuit

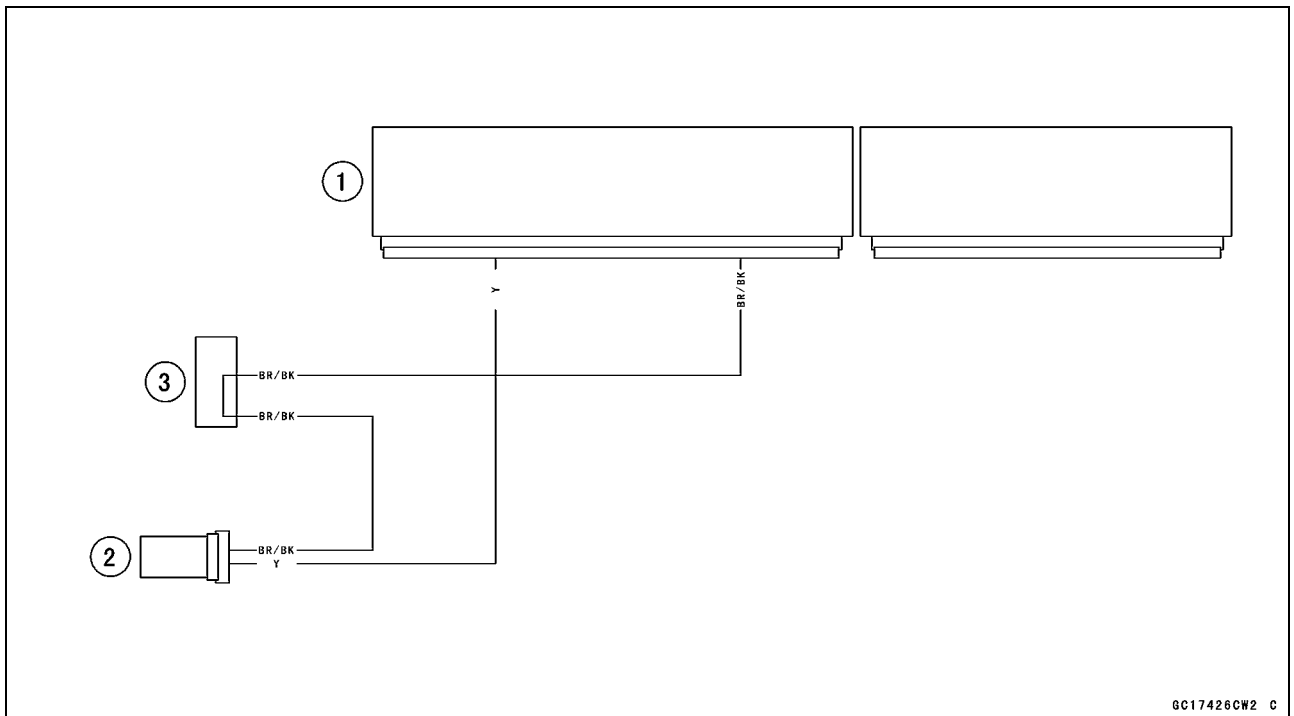

6C17426CW2 C

- 1. ECU
- 2. Inlet Air Temperature Sensor
- 3. Water-proof Joint 2

3-60 FUEL SYSTEM (DFI)

Water Temperature Sensor (Service Code 14)

Removal/Installation

CAUTION

Never drop the sensor, especially on a hard surface. Such a shock to the sensor can damage it.

- Drain the coolant (see Coolant Change in the Periodic Maintenance chapter).
 - Remove:
 - Throttle Body Assy (see Throttle Body Assy Removal Connector [A])
 - Water Temperature Sensor [B]
 - Replace the gasket with a new one, and tighten the water temperature sensor.
- Torque - Water Temperature Sensor: 25 N·m (2.5 kgf·m, 18 ft·lb)**
- Fill the engine with coolant and bleed the air from the cooling system (see Coolant Change in the Periodic Maintenance chapter).

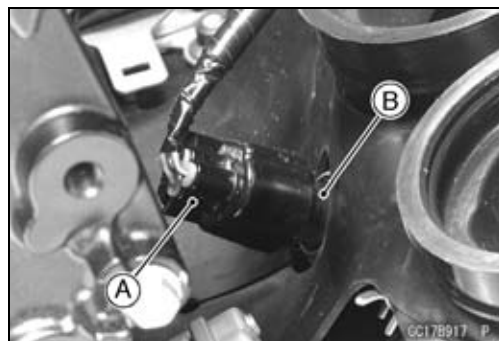

Output Voltage Inspection

NOTE

○Be sure the battery is fully charged.

- Remove the ECU (see ECU Removal).
- Do not disconnect the ECU connectors.
- Connect a digital meter [A] to the ECU connectors [B], with the needle adapter set.

Special Tool - Needle Adapter Set: 57001-1457

Water Temperature Sensor Output Voltage Connections to ECU

Meter (+) → O lead (terminal 25)

Meter (-) → BR/BK lead (terminal 34)

- Measure the sensor output voltage with the engine stopped and the connector joined.
- Turn the ignition switch ON.

Output Voltage at ECU

Standard: About 2.80 ~ 2.97 V at 20°C (68°F)

NOTE

○The output voltage changes according to the coolant temperature in the engine.

- Turn the ignition switch OFF.
- ★ If the output voltage is out of the specified, check the ECU for its ground, and power supply (see ECU Power Supply Inspection).
- ★ If the ground and power supply are good, replace the ECU (see ECU section).
- ★ If the output voltage is far out of the specified (e.g. when the wiring is open, the voltage is about 5V), check the wiring (see wiring diagram in this section).
- ★ If the wiring is good, check the water temperature sensor resistance.

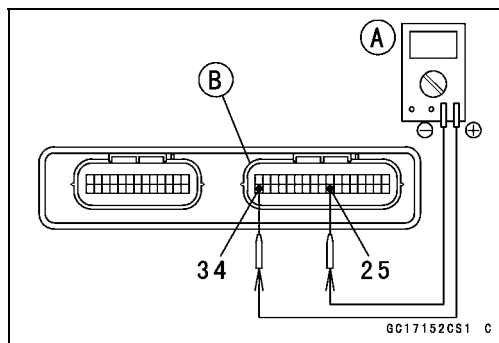

Water Temperature Sensor (Service Code 14)

Sensor Resistance Inspection

- Refer to the Water Temperature Sensor Inspection in the Electrical System chapter (see Water Temperature Sensor Inspection in the Electrical System chapter).

Water Temperature Sensor Circuit

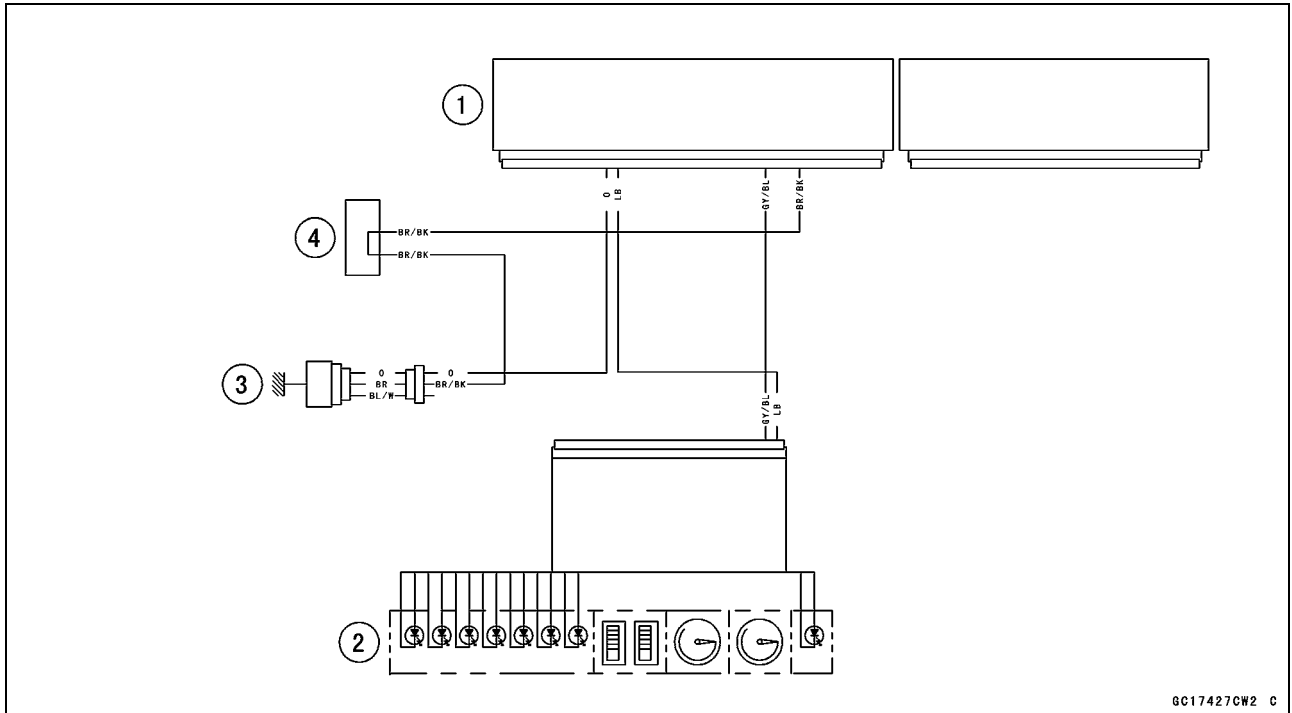

1. ECU
2. Meter Unit
3. Water Temperature Sensor
4. Water-proof Joint 2

3-62 FUEL SYSTEM (DFI)

Atmospheric Pressure Sensor (Service Code 15)

CAUTION

Never drop the sensor, especially on a hard surface.
Such a shock to the sensor can damage it.

Removal

- Remove:
 - Seat (see Seat Removal in the Frame chapter)
 - Atmospheric Pressure Sensor Connector [A]
 - Damper [B]
 - Atmospheric Pressure Sensor [C]

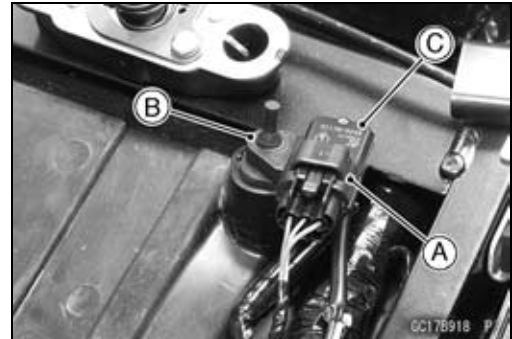

Installation

NOTE

○The atmospheric pressure sensor is the same part as the inlet air pressure sensor except that the inlet air pressure sensor has a inlet air pressure hose and different wiring.

- Installation is reverse of removal.

Input Voltage Inspection

NOTE

○Be sure the battery is fully charged.
○The inspection is the same as "Input Voltage Inspection" of the throttle sensor and the inlet air pressure sensor.

- Turn the ignition switch OFF.
- Remove the ECU (see ECU Removal).
- Do not disconnect the ECU connectors.
- Connect a digital meter [A] to the connector [B], with the needle adapter set.

Special Tool - Needle Adapter Set: 57001-1457

Atmospheric Pressure Sensor Input Voltage Connections to ECU Connector

Meter (+) → BL lead (terminal 7)

Meter (-) → BR/BK lead (terminal 34)

- Measure the input voltage with the engine stopped, and with the connectors joined.
- Turn the ignition switch ON.

Input Voltage at ECU

Standard: DC 4.75 ~ 5.25 V

- ★ If the reading of input voltage is less than the standard range, check the ECU for its ground, and power supply (see ECU Power Supply Inspection).
- ★ If the ground and power supply are good, replace the ECU (see ECU section).

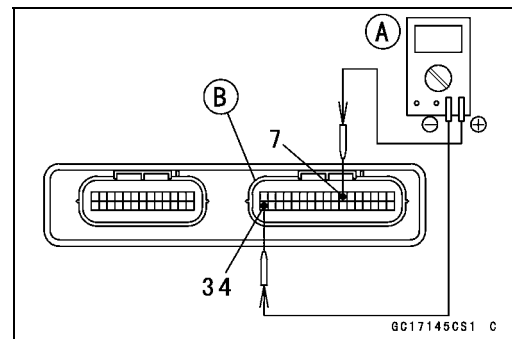

Atmospheric Pressure Sensor (Service Code 15)

★ If the reading is within the standard range, remove the seat, and check the input voltage again at the sensor connector.

- Disconnect the atmospheric pressure sensor connector and connect the harness adapter [A] between the harness connector and atmospheric pressure sensor connector.

Special Tool - Sensor Harness Adapter: 57001-1561

- Connect a digital meter to the harness adapter leads. Atmospheric Pressure Sensor [B]

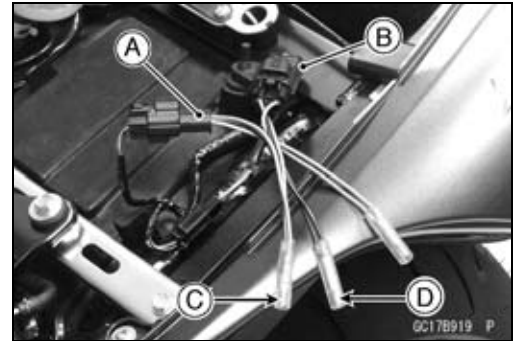

Atmospheric Pressure Sensor Input Voltage Connections to Adapter

Meter (+) → G (sensor BL) lead [C]

Meter (-) → BK (sensor BR/BK) lead [D]

- Measure the input voltage with the engine stopped, and with the connector joined.
- Turn the ignition switch ON.

Input Voltage at Sensor Connector

Standard: DC 4.75 ~ 5.25 V

- Turn the ignition switch OFF.
- ★ If the reading is out of the standard range, check the wiring (see wiring diagram in this section).
- ★ If the reading is good, the input voltage is normal. Check the output voltage.

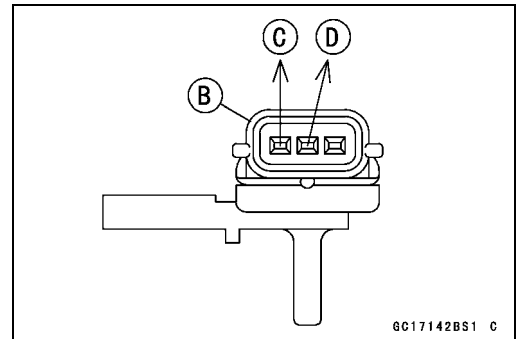

Output Voltage Inspection

- Measure the output voltage at the ECU in the same way as input voltage inspection. Note the following.

Digital Meter [A]

ECU Connector [B]

Special Tool - Needle Adapter Set: 57001-1457

Atmospheric Pressure Sensor Output Voltage Connections to ECU Connector

Meter (+) → G/W lead (terminal 11)

Meter (-) → BR/BK lead (terminal 34)

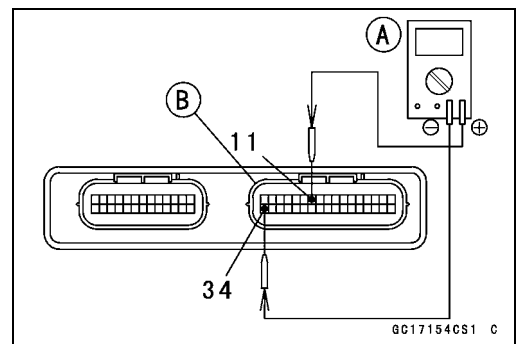

Output Voltage

Usable Range: DC 3.80 ~ 4.20 V at the standard atmospheric pressure (101.32 kPa, 76 cmHg abs.)

NOTE

- The output voltage changes according to the local atmospheric pressure.
- The atmospheric sensor output voltage is based on a nearly perfect vacuum in the small chamber of the sensor. So, the sensor indicates absolute atmospheric pressure.
- ★ If the output voltage is within the usable range, check the ECU for its ground, and power supply (see ECU Power Supply Inspection).
- ★ If the ground and power supply are good, replace the ECU (see ECU section).

3-64 FUEL SYSTEM (DFI)

Atmospheric Pressure Sensor (Service Code 15)

- ★ If the output voltage is far out of the usable range, check the output voltage at the sensor connector [A] (when the wiring is open, the output voltage is about 1.8 V).
- Connect a digital meter [A] to the harness adapter leads. Atmospheric Pressure Sensor [B]

Special Tool - Sensor Harness Adapter: 57001-1561

Atmospheric Pressure Sensor Output Voltage Connections to Adapter

Meter (+) → G/W (sensor G/W) lead [C]

Meter (-) → BK (sensor BR/BK) lead [D]

Output Voltage at Sensor

Usable Range: DC 3.80 ~ 4.20 V at the standard atmospheric pressure (101.32 kPa, 76 cmHg abs.)

- Turn the ignition switch OFF.
- ★ If the output voltage is normal, check the wiring for continuity (see wiring diagram in this section).
- ★ If the output voltage is out of the usable range, replace the sensor.

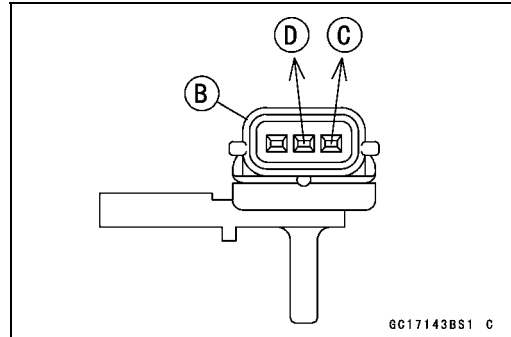
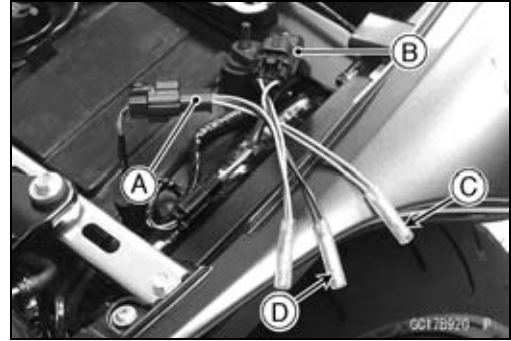

Atmospheric Pressure Sensor Circuit

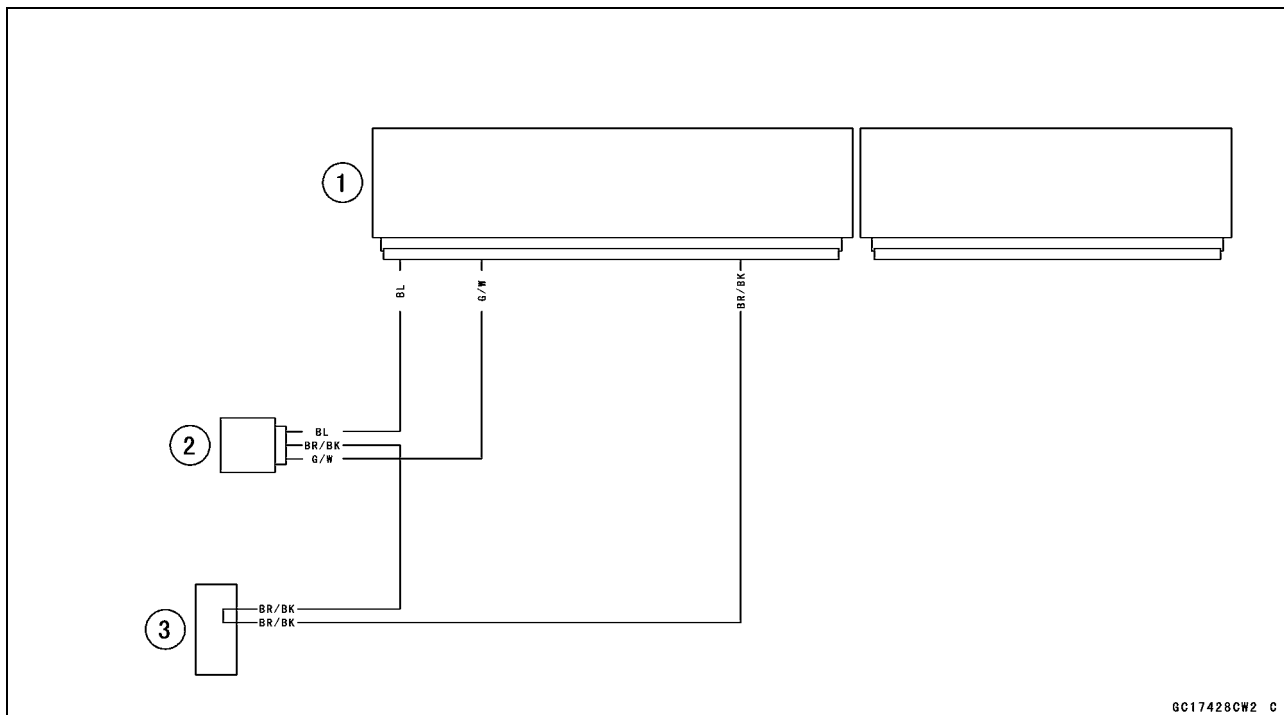

1. ECU
2. Atmospheric Pressure Sensor
3. Water-proof Joint 2

- ★ If you need to check the atmospheric pressure sensor for various altitudes other than sea level, check the output voltage as follows.

○ Determine the local altitude (Elevation).

Atmospheric Pressure Sensor (Service Code 15)

★ If you know the local atmospheric pressure using a barometer, substitute the atmospheric pressure for throttle vacuum pressure in the inlet air pressure sensor chart (see Inlet Air Pressure Sensor section). And get the usable range of the atmospheric pressure sensor output voltage and check if output voltage is within the standard or not in the same way as Output Voltage Inspection of the inlet air pressure sensor.

★ If you know the local altitude, use the following chart.

Atmospheric Pressure/Altitude Relationship

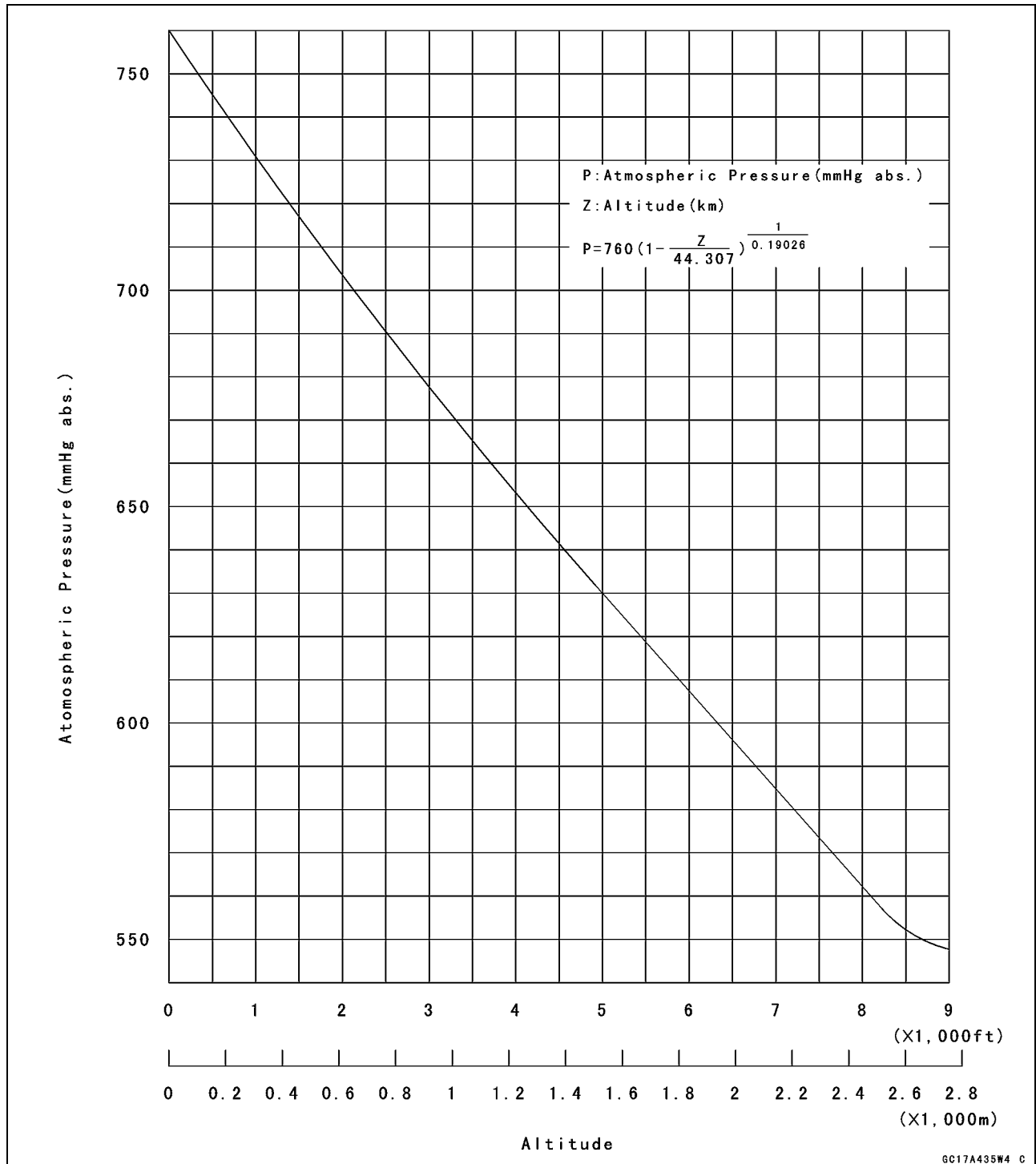

3-66 FUEL SYSTEM (DFI)

Crankshaft Sensor (Service Code 21)

Crankshaft Sensor Removal/Installation

- Refer to the Crankshaft Sensor Removal/Installation in the Electrical System chapter (see Crankshaft Sensor Removal/Installation in the Electrical System chapter).

Crankshaft Sensor Inspection

- The crankshaft has no power source, and when the engine stops, the crankshaft generates no signals.
- Crank the engine and measure the peak voltage of the crankshaft sensor (see Crankshaft Sensor Peak Voltage Inspection in the Electrical System chapter) in order to check the sensor.
- Check the wiring for continuity (see wiring diagram in this section).

Crankshaft Sensor Circuit

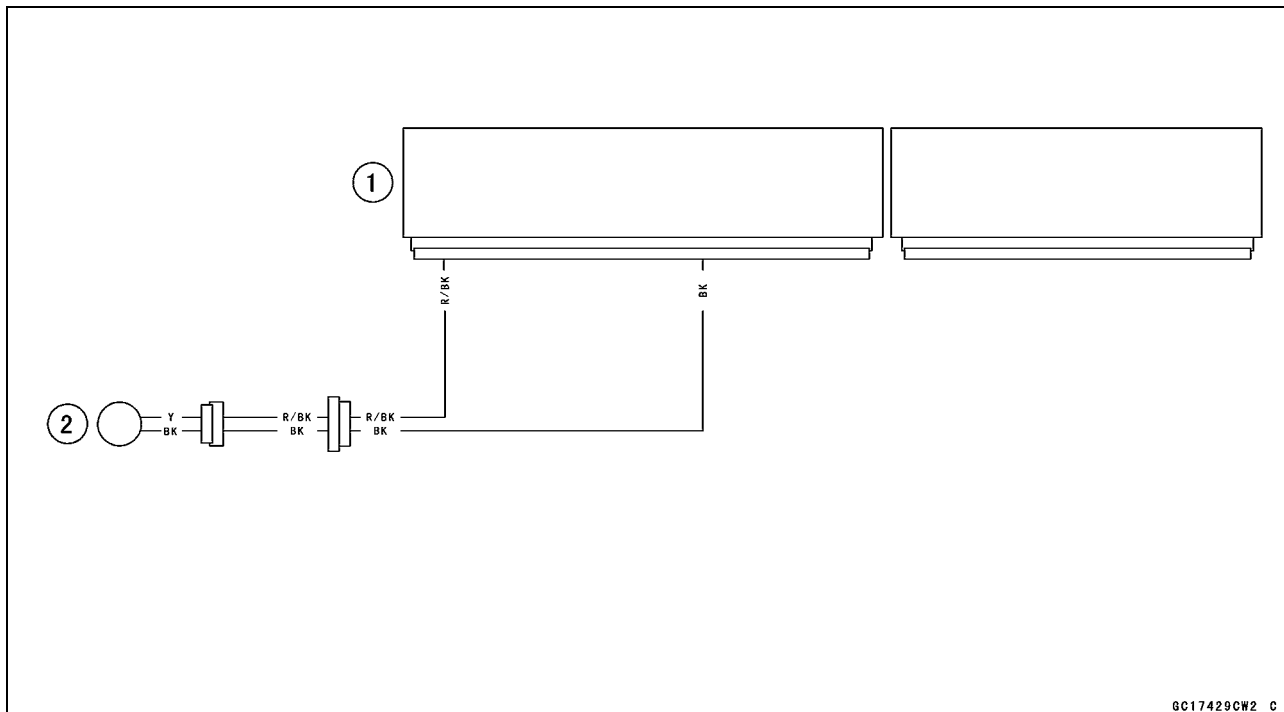

6C17429CW2 C

1. ECU
2. Crankshaft Sensor

Camshaft Position Sensor (Service Code 23)

Camshaft Position Sensor Removal/Installation

The camshaft position sensor detects the position of the camshaft, and distinguishes the cylinder.

- Refer to the Camshaft Position Sensor Removal/Installation in the Electrical System chapter (see Camshaft Position Sensor Removal/Installation in the Electrical System chapter).

Camshaft Position Sensor Inspection

- The camshaft position sensor have no power source, and when the engine stops, the camshaft position sensor generates no signal.
- Crank the engine and measure the peak voltage of the camshaft position sensor (see Camshaft Position Sensor Peak Voltage Inspection in the Electrical System chapter) in order to check the sensor.
- Check the wiring for continuity (see wiring diagram in this section).

Camshaft Position Sensor Circuit

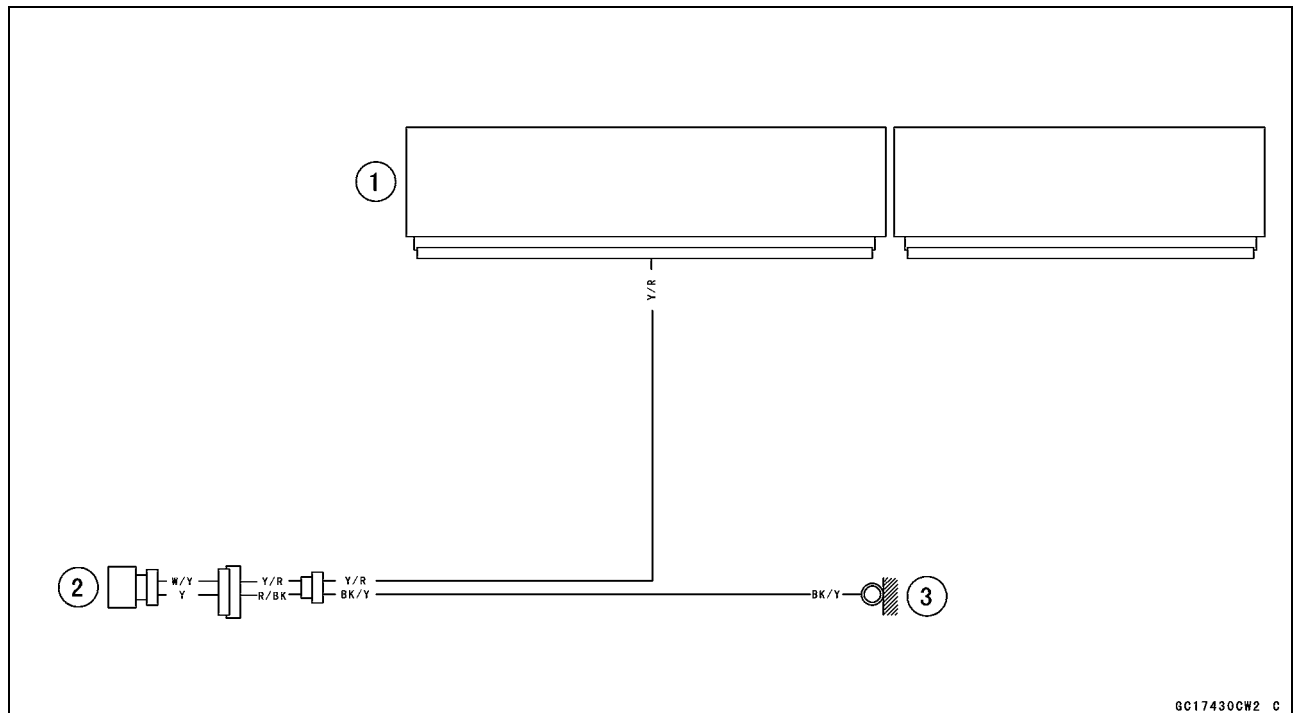

1. ECU
2. Camshaft Position Sensor
3. Frame Ground 1

3-68 FUEL SYSTEM (DFI)

Speed Sensor (Service Code 24)

Speed Sensor Removal/Installation

- Refer to the Speed Sensor Removal/Installation in the Electrical System chapter (see Speed Sensor Removal/Installation in the Electrical System chapter).

Speed Sensor Inspection

- Refer to the Speed Sensor Inspection in the Electrical System chapter (see Speed Sensor Inspection in the Electrical System chapter).

Input Voltage Inspection

NOTE

○ Be sure the battery is fully charged.

- Turn the ignition switch OFF.
 - Disconnect the speed sensor connector [A].
 - Connect the harness adapter [A] between the harness connector and speed sensor connector.
- Special Tool - Throttle Sensor Setting Adapter #1: 57001-1400**
- Connect a digital meter to the harness adapter leads.

Speed Sensor Input Voltage Connections to Adapter

Meter (+) → BL (sensor P) lead [B]

Meter (-) → BK/BL (sensor BK) lead [C]

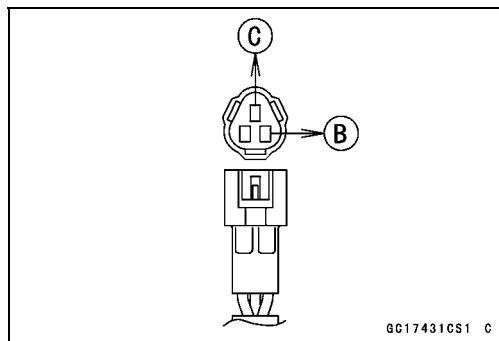
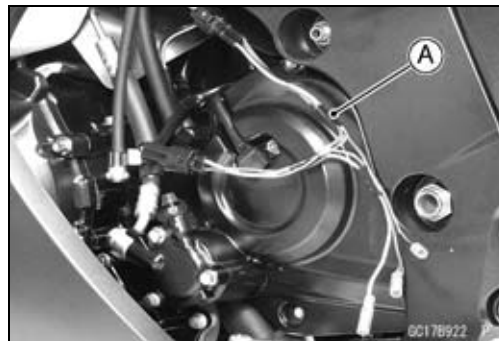
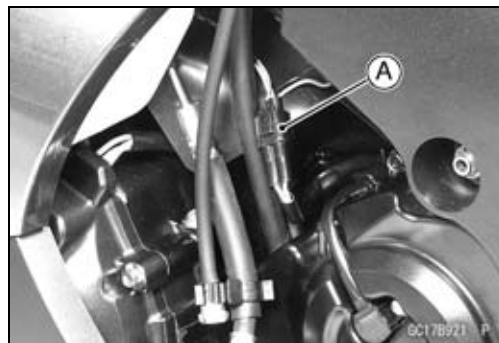

- Measure the input voltage with the engine stopped, and with the connector joined.
- Turn the ignition switch ON.

Input Voltage

Standard: About DC 9 ~ 11 V

- Turn the ignition switch OFF.
- ★ If the reading is out of the range, check the wiring (see wiring diagram in this section), and meter unit (see Electronic Combination Meter Unit Inspection in the Electrical System chapter).
- ★ If the reading is good, check the output voltage.

Speed Sensor (Service Code 24)

Output Voltage Inspection

- Before this inspection, inspect the input voltage (see Input Voltage Inspection in this section).

NOTE

○Be sure the battery is fully charged.

- Turn the ignition switch OFF.
- Using the stand, raise the rear wheel off the ground.
- Disconnect the speed sensor connector [A] and connect the harness adapter [B] between the harness connector and speed sensor connector.
- Connect a digital meter to the harness adapter leads.

Special Tool - Throttle Sensor Setting Adapter #1: 57001-1400

Speed Sensor Output Voltage Connections to Adapter

Meter (+) → BY (sensor BL/Y) lead [C]

Meter (-) → BK/BL (sensor BK) lead [D]

- Measure the output voltage with the engine stopped, and with the connector joined.
- Turn the ignition switch ON.

Output Voltage at Sensor

Standard: About DC 0.05 ~ 0.09 V or DC 4.5 ~ 4.9

- Rotate the rear wheel by hand, confirm the output voltage will be raise or lower.
- Turn the ignition switch OFF.
- ★ If the reading is out of the range, check the speed sensor (see Speed Sensor Inspection in the Electrical System chapter) and the wiring to ECU (see wiring diagram in this section).
- ★ If the reading, speed sensor and wiring are good, replace the ECU (see ECU section).

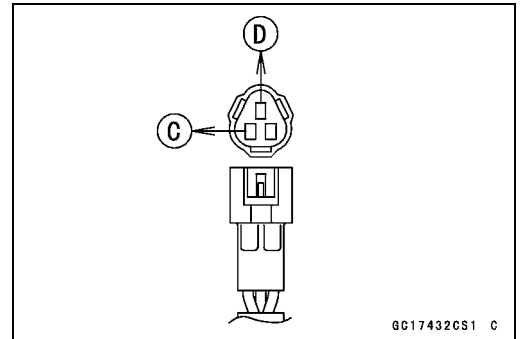
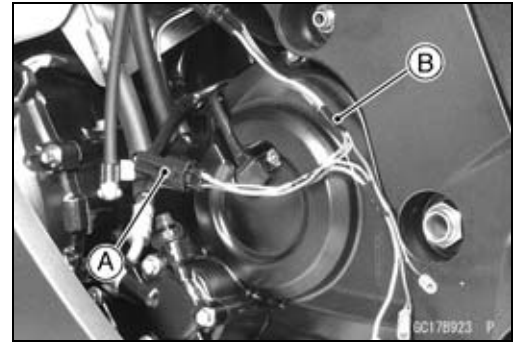

3-70 FUEL SYSTEM (DFI)

Speed Sensor (Service Code 24)

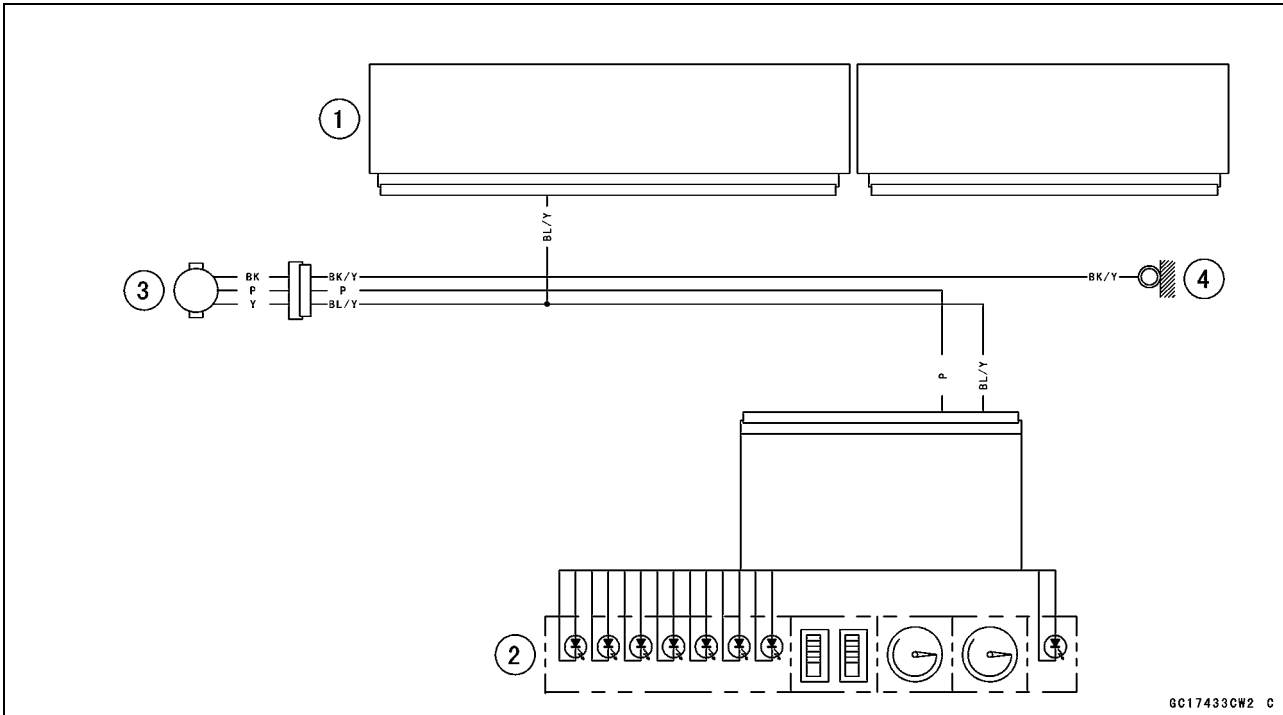

1. ECU
2. Meter Unit
3. Speed Sensor
4. Frame Ground 1

Gear Position Switch (Service Code 25)

Gear Position Switch Removal/Installation

- Refer to the Gear Position Switch Removal/Installation in the Electrical System chapter (see Gear Position Switch Removal/Installation in the Electrical System chapter).

Gear Position Switch Inspection

- Refer to the Gear Position Switch Inspection in the Electrical System chapter (see Gear Position Switch Inspection in the Electrical System chapter).

Input Voltage Inspection

NOTE

○Be sure the battery is fully charged.

- Turn the ignition switch OFF.
- Remove the ECU (see ECU Removal).
- Do not disconnect the ECU connectors.
- Connect a digital meter [A] to the connector, with the needle adapter set.

Special Tool - Needle Adapter Set: 57001-1457

**Gear Position Switch Input Voltage at 1 ~ 6 Gear Positions
Connections to ECU Connector**

Meter (+) → G/R lead (terminal 4)

Meter (-) → Engine Ground

- Measure the switch input voltage with the engine stopped, and with the connector joined.
- Turn the ignition switch ON.

Input Voltage at 1 ~ 6 Gear Positions

Standard:

1st	About 3.0 V
2nd	About 2.5 V
3rd	About 2.0 V
4th	About 1.5 V
5th	About 1.1 V
6th	About 0.7 V

- Turn the ignition switch OFF.
- ★ If the reading is out of the range, check the gear position switch (see Gear Position Switch Inspection in the Electrical System chapter).
- ★ If the switch is good, check the ECU for its ground and power supply (see ECU Power Supply Inspection).
- ★ If the ground and power supply are good, replace the ECU (see ECU section).

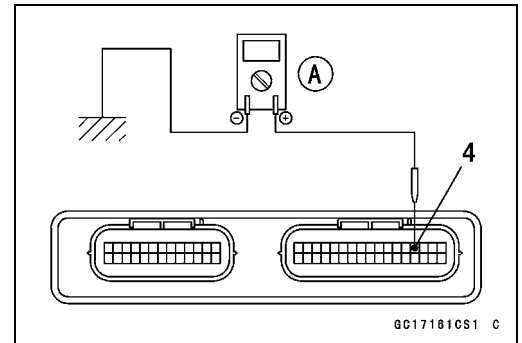

3-72 FUEL SYSTEM (DFI)

Gear Position Switch (Service Code 25)

Gear Position Switch Circuit

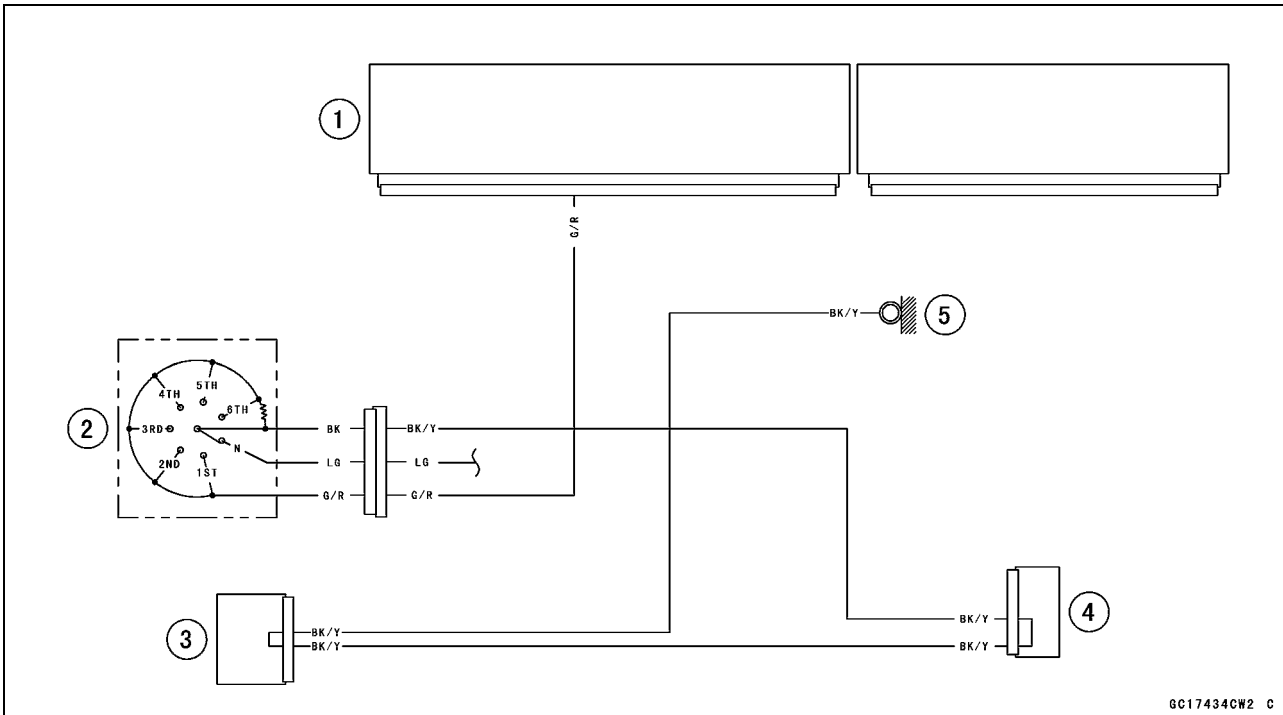

1. ECU
2. Gear Position Switch
3. Joint Connector 1
4. Joint Connector 2
5. Frame Ground 1

Vehicle-down Sensor (Service Code 31)

This sensor has a weight [A] with two magnets inside, and sends a signal to the ECU. But when the motorcycle banks 60 ~ 70° or more to either side (in fact falls down), the weight turns and shuts off the signal. The ECU senses this change, and stops the fuel pump, the fuel injectors, and the ignition system.

Hall IC [B]

When the motorcycle is down, the ignition switch is left ON. If the starter button is pushed, the electric starter turns but the engine doesn't start. To start the engine again, raise the motorcycle, turn the ignition switch OFF, and then ON. When the ignition switch is turned ON, current flows through the latch-up circuit and the transistor in the circuit is turned ON to unlock the latch-up circuit.

Vehicle-down Sensor [A]

Ground Terminal BR/BK [B]

Output Terminal Y/G [C]

Power Source Terminal BL [D]

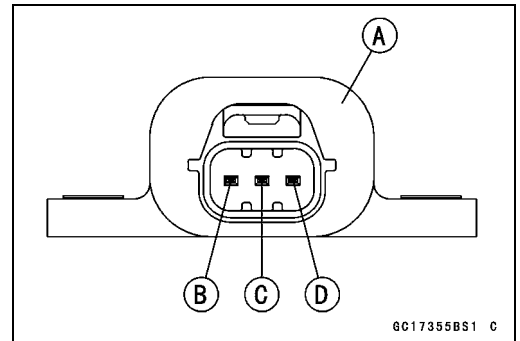
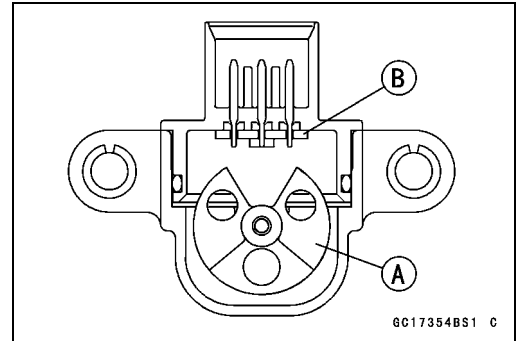

Removal

CAUTION
Never drop the vehicle-down sensor, especially on a hard surface. Such a shock to the sensor can damage it.

- Remove:
 - Windshield (see Windshield Removal in the Frame chapter)
 - Bolts [A]
- Remove:
 - Connector [A]
 - Bolts [B]
 - Vehicle-down Sensor [C]

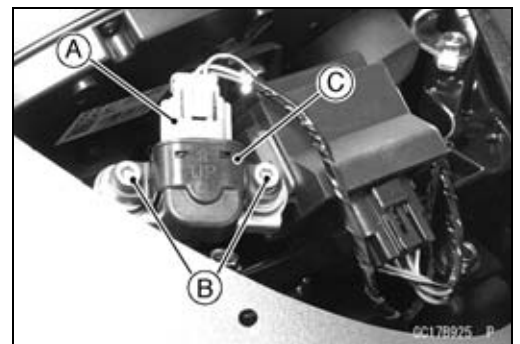
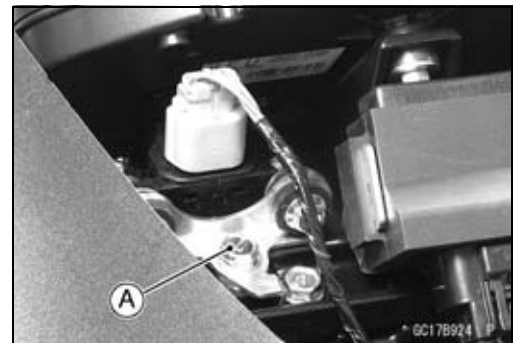

Installation

- The UP mark [A] of the sensor should face upward.

⚠ WARNING
Incorrect installation of the vehicle-down sensor could cause sudden loss of engine power. The rider could lose balance during certain riding situations, like leaning over in a turn, with the potential for an accident resulting in injury or death. Ensure that the vehicle-down sensor is held in place by the sensor brackets.

- Tighten:
 - Torque - Vehicle-down Sensor Bolts: 5.9 N·m (0.60 kgf·m, 53 in·lb)

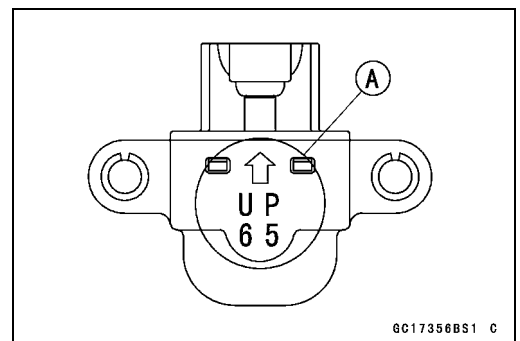

3-74 FUEL SYSTEM (DFI)

Vehicle-down Sensor (Service Code 31)

Inspection

NOTE

○Be sure the battery is fully charged.

- Remove the Windshield (see Windshield Removal in the Frame chapter).
- Connect a digital meter [A] to the connector of the vehicle-down sensor [B], with the needle adapter set [C].

Special Tool - Needle Adapter Set: 57001-1457

Vehicle-down sensor Power Source Voltage Connections to Sensor

Meter (+) → BL lead [D]

Meter (-) → BR/BK lead [E]

- Turn the ignition switch ON, and measure the power source voltage with the connector joined.

Power Source Voltage at Sensor

Standard: DC 4.75 ~ 5.25 V

- Turn the ignition switch OFF.
- ★ If there is no voltage, check the following.
 - Battery (see Charging Condition Inspection in the Electrical System chapter)
 - ECU Fuse 15 A (see Fuse Inspection in the Electrical System chapter)
- ★ If the power source is normal, check the output voltage.

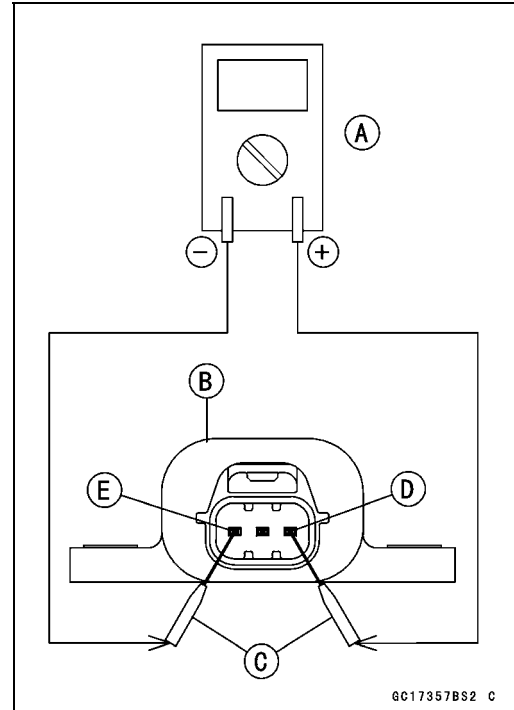

Vehicle-down Sensor (Service Code 31)

- Turn the ignition switch OFF.
- Remove the vehicle-down sensor.
- Do not disconnect the sensor connector.
- Connect a digital meter [A] to the connector, with needle adapter set [B].

Special Tool - Needle Adapter Set: 57001-1457

Vehicle-down sensor Output Voltage

Connections to Sensor

Meter (+) → Y/G lead [C]

Meter (-) → BR/BK lead [D]

- Hold the sensor vertically.
- Turn the ignition switch ON, and measure the output voltage with the connector joined.
- Tilt the sensor 60 ~ 70° or more [E] right or left, then hold the sensor almost vertical with the arrow mark pointed up, and measure the output voltage.

Output Voltage at Sensor

Standard: with sensor arrow mark pointed up: 3.55 ~ 4.45 V

with sensor tilted 60 ~ 70° or more right or left: 0.65 ~ 1.35 V

NOTE

○ If you need to test again, turn the ignition switch OFF, and then ON.

- Turn the ignition switch OFF.
- ★ If the output voltage is out of the specified, replace the vehicle-down sensor.

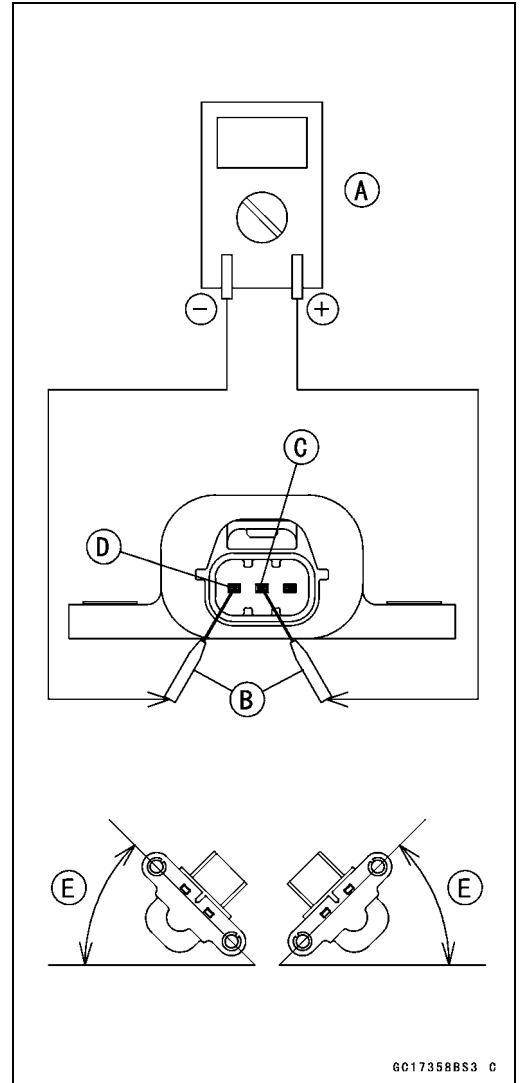

6C17358BS3 C

Vehicle-down Sensor Circuit

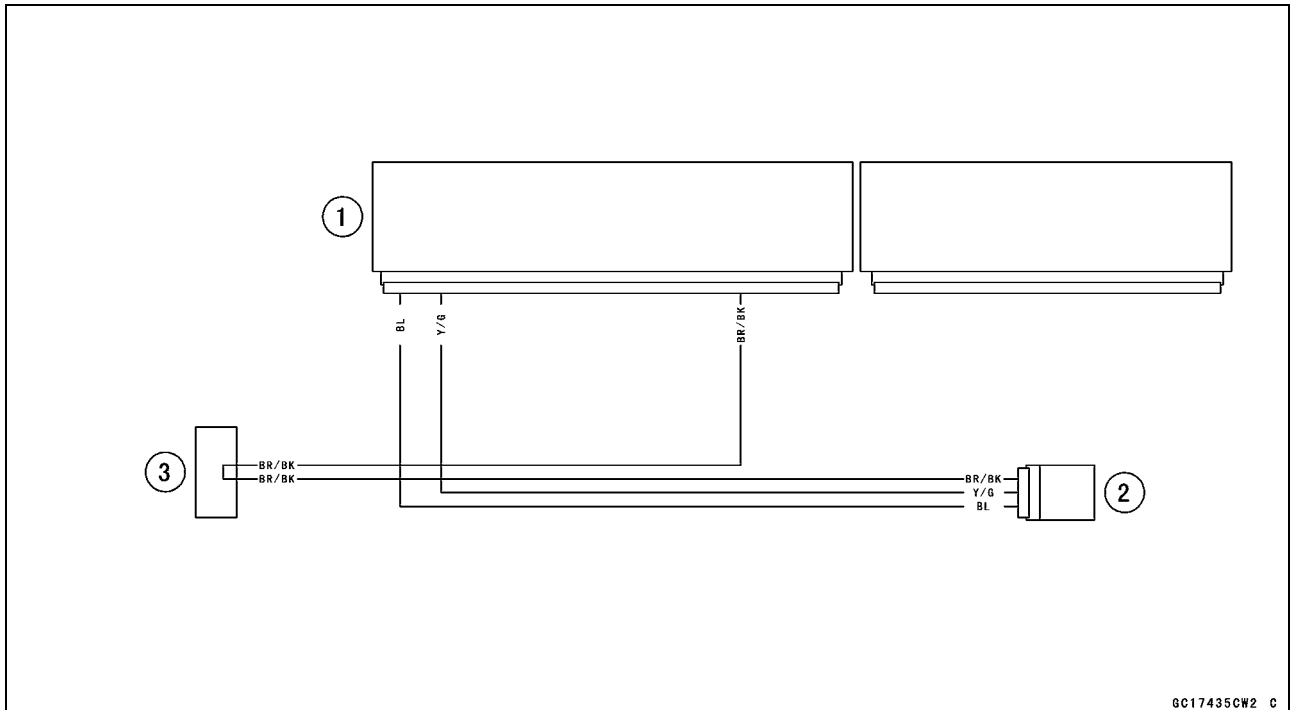

6C17435CW2 C

- 1. ECU
- 2. Vehicle-down Sensor

3. Water-proof Joint 2

3-76 FUEL SYSTEM (DFI)

Subthrottle Sensor (Service Code 32)

The subthrottle sensor is a rotating variable resistor that change output voltage according to throttle operating. The ECU senses this voltage change and determines fuel injection quantity, and ignition timing according to engine rpm, and throttle opening.

Input Terminal [A]

Output Terminal [B]

Ground Terminal [C]

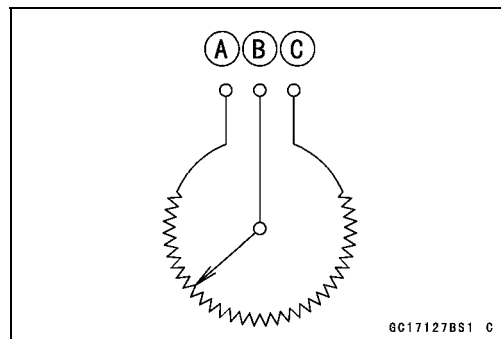

Subthrottle Sensor Removal/Adjustment

CAUTION

Do not remove or adjust the subthrottle sensor [A] since it has been adjusted and set with precision at the factory.

Never drop the throttle body assy, especially on a hard surface. Such a shock to the sensor can damage it.

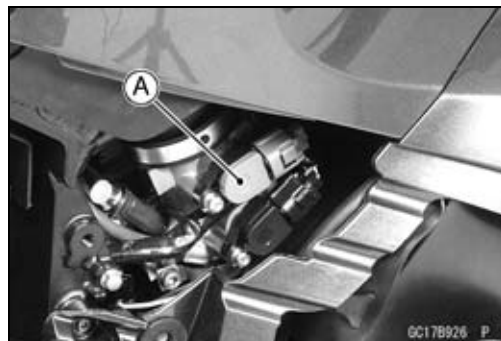

Input Voltage Inspection

NOTE

○Be sure the battery is fully charged.

- Turn the ignition switch OFF.
- Remove the ECU (see ECU Removal).
- Do not disconnect the ECU connectors.
- Connect a digital meter [A] to the connector [B], using the needle adapter set.

Special Tool - Needle Adapter Set: 57001-1457

Subthrottle Sensor Input Voltage Connections to ECU Connector

Meter (+) → BL lead (terminal 7)

Meter (-) → BR/BK lead (terminal 34)

- Measure the input voltage with the engine stopped, and with the connectors joined.
- Turn the ignition switch ON.

Input Voltage at ECU Connector

Standard: DC 4.75 ~ 5.25 V

- Turn the ignition switch OFF.
- ★ If the reading of input voltage is less than the standard, check the ECU for its ground, power supply and wiring shorted.
- ★ If the ground and power supply are good, replace the ECU (see ECU section).
- ★ If the input voltage is within the standard range, check the input voltage at the subthrottle sensor connector.

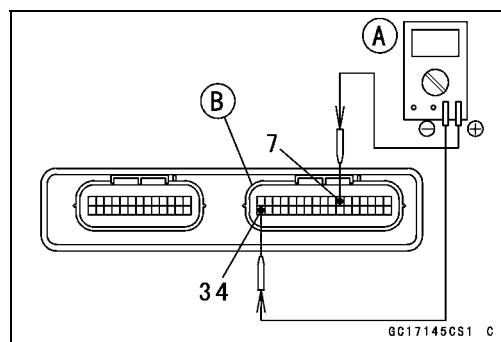

Subthrottle Sensor (Service Code 32)

- Remove the right fairing cover (see Fairing Cover Removal in the Frame chapter).
- Disconnect the subthrottle sensor connector [A].

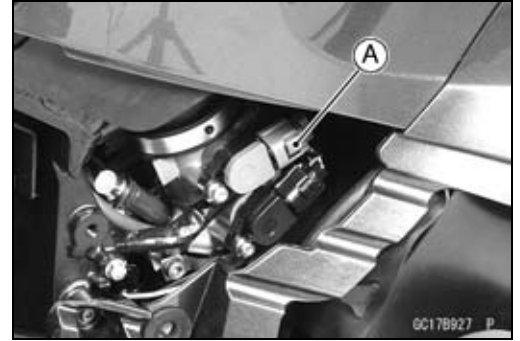

- Connect the harness adapter [A] between the harness connector and subthrottle sensor connector.

Special Tool - Throttle Sensor Setting Adapter: 57001-1538

- Connect a digital meter to the harness adapter leads.

Subthrottle Sensor Input Voltage Connections to Adapter

Meter (+) → BK (sensor BL) lead

Meter (-) → W (sensor BR/BK) lead

- Measure the sensor input voltage with the engine stopped, and with the connector joined.
- Turn the ignition switch ON.

Input Voltage at Sensor

Standard: DC 4.75 ~ 5.25 V

- Turn the ignition switch OFF.
- ★ If the reading is out of the range, check the wiring (see wiring diagram in this section).
- ★ If the reading is good, check the output voltage of the sensor.

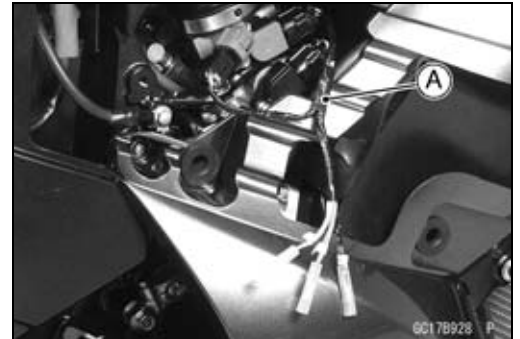

3-78 FUEL SYSTEM (DFI)

Subthrottle Sensor (Service Code 32)

Output Voltage Inspection

- Measure the output voltage at the ECU in the same way as input voltage inspection. Note the following.

Digital Meter [A]

Connector [B]

Special Tool - Needle Adapter Set: 57001-1457

Subthrottle Sensor Output Voltage

Connections to ECU Connector

Meter (+) → BL/W lead (terminal 27)

Meter (-) → BR/BK lead (terminal 34)

- Remove the air cleaner caps (see Throttle Body Assy Removal).
- Turn the ignition switch ON.
- Measure the output voltage when the subthrottle valve is fully opened or completely closed by hand.

Output Voltage at ECU

Standard: DC 0.62 ~ 4.14 V (at subthrottle valve full opening to closing)

NOTE

○ *The throttle sensor is operating correctly if the following voltages are obtained:*

- DC 0.62 V (or slightly higher) with the subthrottle valve at the closed position.
- DC 4.14 V (or slightly lower) with the subthrottle valve at the fully open position.

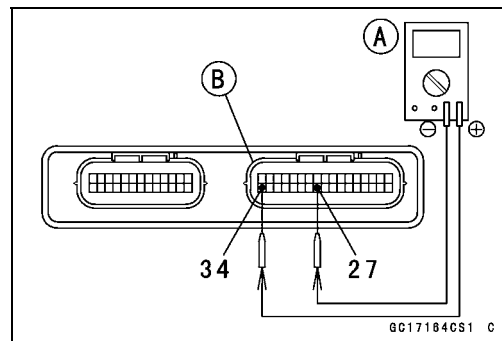

CAUTION

Do not remove or adjust the subthrottle sensor. It has been adjusted and set with precision at the factory.

Never drop the throttle body assy, especially on a hard surface. Such a shock to the sensor can damage it.

- ★ If the output voltage is within the standard range, check the ECU for its ground, and power supply (see ECU Power Supply Inspection).
- ★ If the ground and power supply are good, replace the ECU (see ECU Removal).
- ★ If the output voltage is far out of the standard range (e.g. when the wiring is open, the reading is 0 V), check the output voltage again at the sensor connector.

Subthrottle Sensor (Service Code 32)

- Disconnect the subthrottle sensor connector [A] and connect the harness adapter [B] between the harness connector and subthrottle sensor connector.

Special Tool - Throttle Sensor Harness Adapter: 57001-1538

- Connect a digital meter to the harness adapter leads.

Subthrottle Sensor Output Voltage Connections to Adapter

Meter (+) → R (sensor BL/W) lead

Meter (-) → W (sensor BR/BK) lead

- Measure the output voltage with the engine stopped, and with the connector joined.
- Turn the ignition switch ON.
- Measure the output voltage when the subthrottle valve is fully opened or completely closed by hand.

Output Voltage at Sensor

Standard: DC 0.62 ~ 4.14 V (at subthrottle valve full opening to closing)

NOTE

- *The throttle sensor is operating correctly if the following voltages are obtained:*
 - DC 0.62 V (or slightly higher) with the subthrottle valve at the closed position.
 - DC 4.14 V (or slightly lower) with the subthrottle valve at the fully open position.



CAUTION

Do not remove or adjust the subthrottle sensor. It has been adjusted and set with precision at the factory.
Never drop the throttle body assy, especially on a hard surface. Such a shock to the sensor can damage it.

NOTE

- *The standard voltage refers to the value when the voltage reading at the Input Voltage Inspection shows 5V exactly.*
- *When the input voltage reading shows other than 5V, derive a voltage range as follows.*
Example:
In the case of a input voltage of 4.75 V.
 $0.62 \times 4.75 \div 5.00 = 0.59 \text{ V}$
 $4.14 \times 4.75 \div 5.00 = 3.93 \text{ V}$
Thus, the valid range is 0.59 ~ 3.93 V
- Turn the ignition switch OFF.
- ★ If the reading is out of the standard range, inspect the subthrottle sensor resistance.
- ★ If the output voltage is normal, check the wiring for continuity (see wiring diagram in this section).

3-80 FUEL SYSTEM (DFI)

Subthrottle Sensor (Service Code 32)

Resistance Inspection

- Turn the ignition switch OFF.
- Disconnect the subthrottle sensor connector.
- Connect a digital meter [A] to the subthrottle sensor connector [B].
- Measure the subthrottle sensor resistance.

Subthrottle Sensor Resistance

Connections: BL lead [C] ↔ BR/BK lead [D]

Standard: 4 ~ 6 kΩ

- ★ If the reading is out of the range, replace the throttle body assy (see Throttle Body Assy section).
- ★ If the reading is within the range, but the problem still exists, replace the ECU (see ECU section).

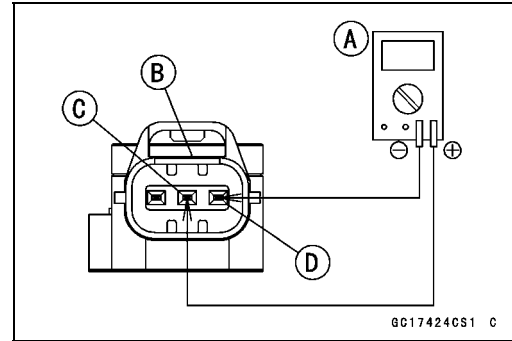

Subthrottle Sensor Circuit

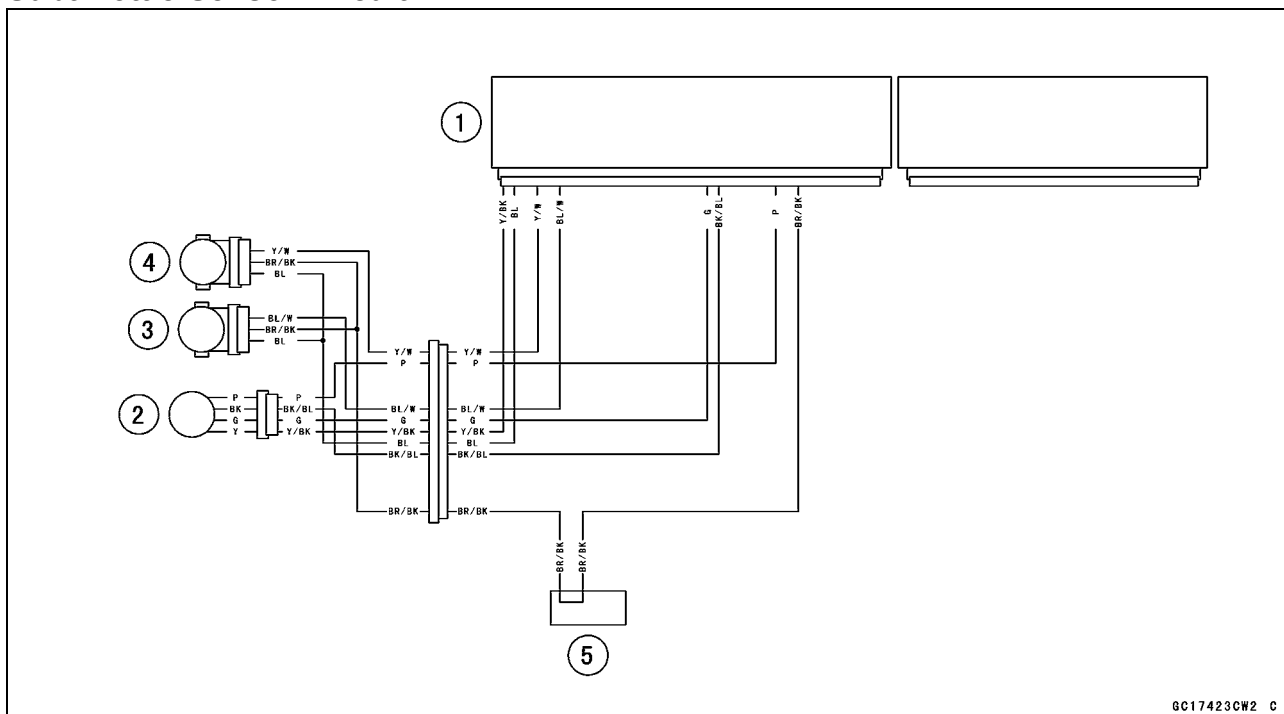

1. ECU
2. Subthrottle Valve Actuator
3. Subthrottle Sensor
4. Main Throttle Sensor
5. Water-proof Joint 2

Immobilizer Amplifier (Service Code 35)

Antenna Resistance Inspection

- Remove the left inner cover (see Inner Cover Removal in the Frame chapter).
- Disconnect the antenna lead connector [A].
- Measure the resistance of the antenna coil in the ignition switch as follows.

**Antenna Resistance
Connections to Antenna**

Meter → BK lead

Meter → BK lead

Standard: About 0.6 ~ 0.9 Ω

- ★ If the resistance is out of the standard range, replace the ignition switch.

Amplifier Input Voltage Inspection

NOTE

○ Be sure the battery is fully charged.

- Turn the ignition switch OFF.
- Remove the windshield (see Windshield Removal in the Frame chapter).
- Connect a digital meter to the amplifier connector [A], using the needle adapter set.

Special Tool - Needle Adapter Set: 57001-1457

**Amplifier Input Voltage
Connections to Connector**

Meter (+) → BR/W lead

Meter (-) → BK/Y lead

- Measure the input voltage with the engine stopped, and with the connector joined.
- Turn the ignition switch ON.

Input Voltage

Standard: Battery Voltage

- Turn the ignition switch OFF.
- ★ If the reading is out of the range, check the wiring (see wiring diagram in next section).
- ★ If the reading and antenna resistance are good, replace the amplifier (see Immobilizer System Parts Replacement in the Electrical System chapter).

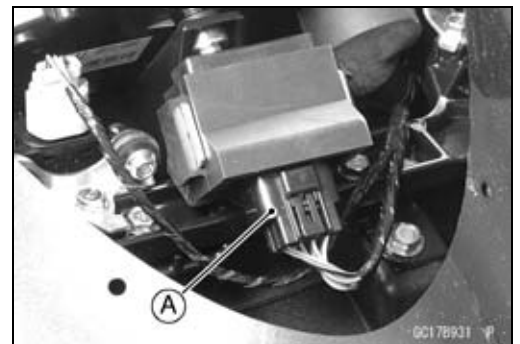
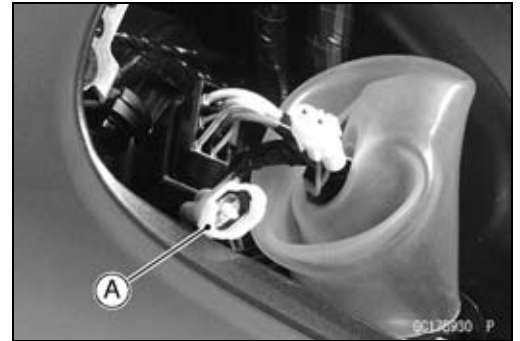

3-82 FUEL SYSTEM (DFI)

Blank Key Detection (Service Code 36)

- This code appears in the following conditions.
- The transponder [A] in the master and/or user key is malfunction.
- When the spare key of unregistration is used.
- When the master key is registered in the registered ECU.
- Therefore, the service code 36 will disappear when the above issue is solved.

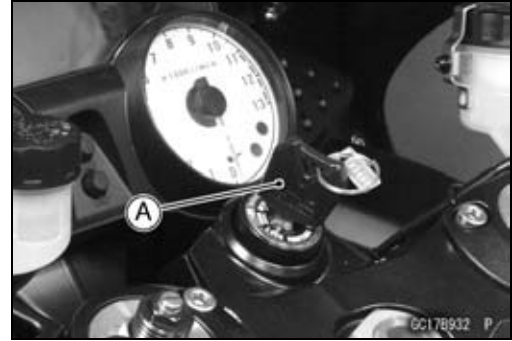

User Key Inspection

- Register the user key correctly (see Key Registration in the Electrical System chapter).
- ★ If the service code 36 appears again, the transponder in the key is malfunction, replace it.

Immobilizer System Circuit

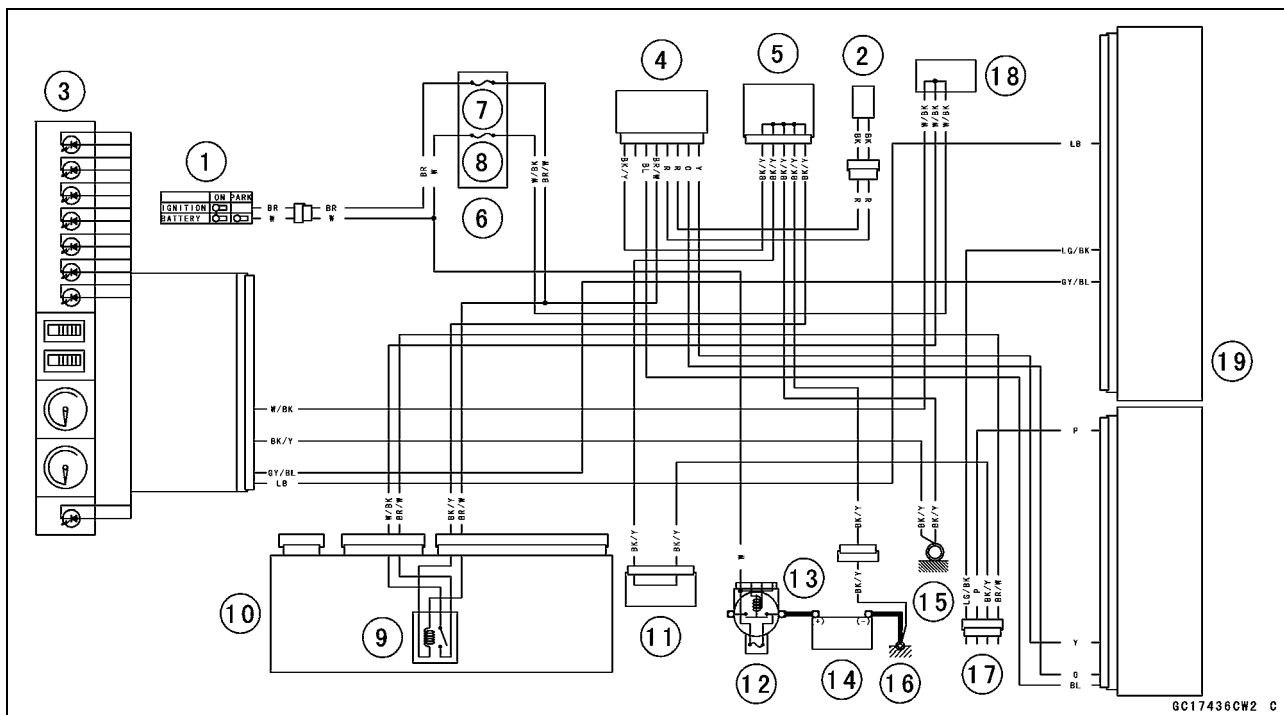

- | | |
|--------------------------|--|
| 1. Ignition Switch | 10. Relay Box |
| 2. Immobilizer Antenna | 11. Joint Connector 2 |
| 3. Meter Unit | 12. Main Fuse 30 A |
| 4. Immobilizer Amplifier | 13. Starter Relay |
| 5. Joint Connector 1 | 14. Battery 12 V 14 Ah |
| 6. Fuse Box × 2 | 15. Frame Ground 1 |
| 7. ECU Fuse 15 A | 16. Frame Ground 2 |
| 8. Ignition Fuse 10 A | 17. Immobilizer/Kawasaki Diagnostic System Connector |
| 9. Main Relay | 18. Water-proof Joint 1 |
| | 19. ECU |

Fuel Pump Relay (Service Code 46)

Fuel Pump Relay Removal

CAUTION
Never drop the relay, especially on a hard surface. Such a shock to the relay can damage it.

- The fuel pump relay is included in the relay box.
- Remove the seat (see Seat Removal in the Frame chapter).
- Remove the relay box [A] from the bracket and disconnect the connectors.



Fuel Pump Relay Inspection

- Remove the relay box (see Fuel Pump Relay Removal).
- Connect the hand tester [A] and one 12 V battery to the relay connector as shown.

Special Tool - Hand Tester: 57001-1394

- Relay Coil Terminals [1] and [2]
- Relay Switch Terminals [3] and [4]

Testing Relay

Tester range: 1 Ω range

Criteria:
 When battery is connected → 0 Ω
 When battery is disconnected → ∞ Ω

★ If the relay does not work as specified, replace the relay box.

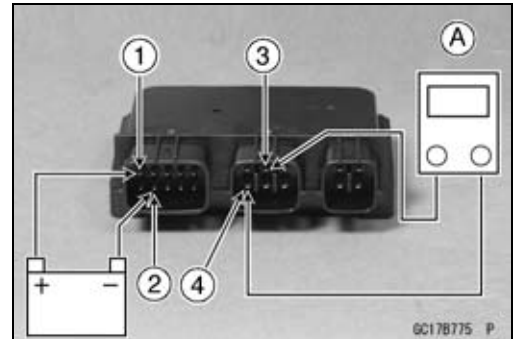

3-84 FUEL SYSTEM (DFI)

Fuel Pump Relay (Service Code 46)

Fuel Pump Relay Circuit

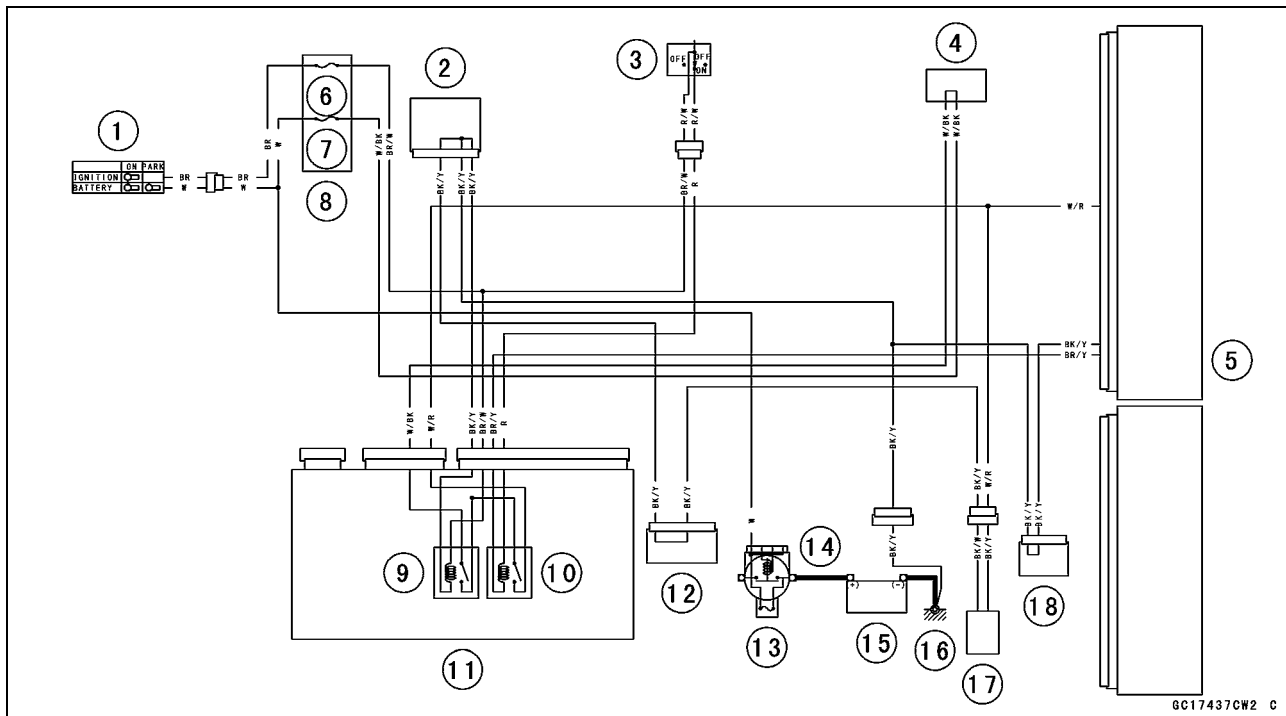

GC17437CW2 C

- | | |
|------------------------|------------------------|
| 1. Ignition Switch | 10. Fuel Pump Relay |
| 2. Joint Connector 1 | 11. Relay Box |
| 3. Engine Stop Switch | 12. Joint Connector 2 |
| 4. Water-proof Joint 1 | 13. Main Fuse 30 A |
| 5. ECU | 14. Starter Relay |
| 6. ECU Fuse 15 A | 15. Battery 12 V 14 Ah |
| 7. Ignition Fuse 10 A | 16. Frame Ground 2 |
| 8. Fuse Box 2 | 17. Fuel Pump |
| 9. Main Relay | 18. Joint Connector 3 |

Stick Coils #1, #2, #3, #4: (Service Code 51, 52, 53, 54)

- Stick Coil #1: Service Code 51
- Stick Coil #2: Service Code 52
- Stick Coil #3: Service Code 53
- Stick Coil #4: Service Code 54

Removal/Installation

CAUTION

Never drop the stick coils, especially on a hard surface. Such a shock to the stick coil can damage it.

- Refer to the Stick Coil (Ignition Coil together with Spark Plug Cap) Removal/Installation in the Electrical System chapter (see Stick Coil (Ignition Coil together with Spark Plug Cap) Removal/Installation in the Electrical System chapter).

Input Voltage Inspection

NOTE

○Be sure the battery is fully charged.

- Turn the ignition switch OFF.
- Remove the ECU (see ECU Removal).
- Do not disconnect the ECU connectors.
- Connect a digital meter [A] as shown, with the needle adapter set.

Special Tool - Needle Adapter Set: 57001-1457

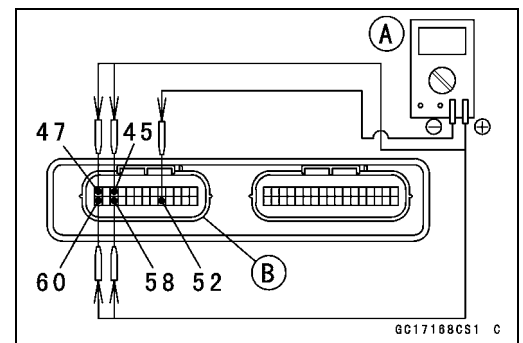

Stick Coil Input Voltage at ECU

Connections for Stick Coil #1

- Meter (+) → W/R lead (terminal 47)
- Meter (-) → BK/Y lead (terminal 52)

Connections for Stick Coil #2

- Meter (+) → W/BL lead (terminal 60)
- Meter (-) → BK/Y lead (terminal 52)

Connections for Stick Coil #3

- Meter (+) → W/G lead (terminal 45)
- Meter (-) → BK/Y lead (terminal 52)

Connections for Stick Coil #4

- Meter (+) → W/Y lead (terminal 58)
- Meter (-) → BK/Y lead (terminal 52)

- Measure the input voltage to each primary winding of the stick coils with the engine stopped, and with the connectors joined.
- Turn the ignition switch ON.

Input Voltage at ECU

Standard: Battery Voltage

- ★ If the reading is out of the standard, check the wiring (see wiring diagram in this section).
- ★ If the reading is good, the input voltage is normal. Crank the engine, and check the peak voltage of the stick coils (see Stick Coil Primary Peak Voltage Inspection in the Electrical System chapter) in order to check the primary coils.

3-86 FUEL SYSTEM (DFI)

Stick Coils #1, #2, #3, #4: (Service Code 51, 52, 53, 54)

Stick Coil Circuit

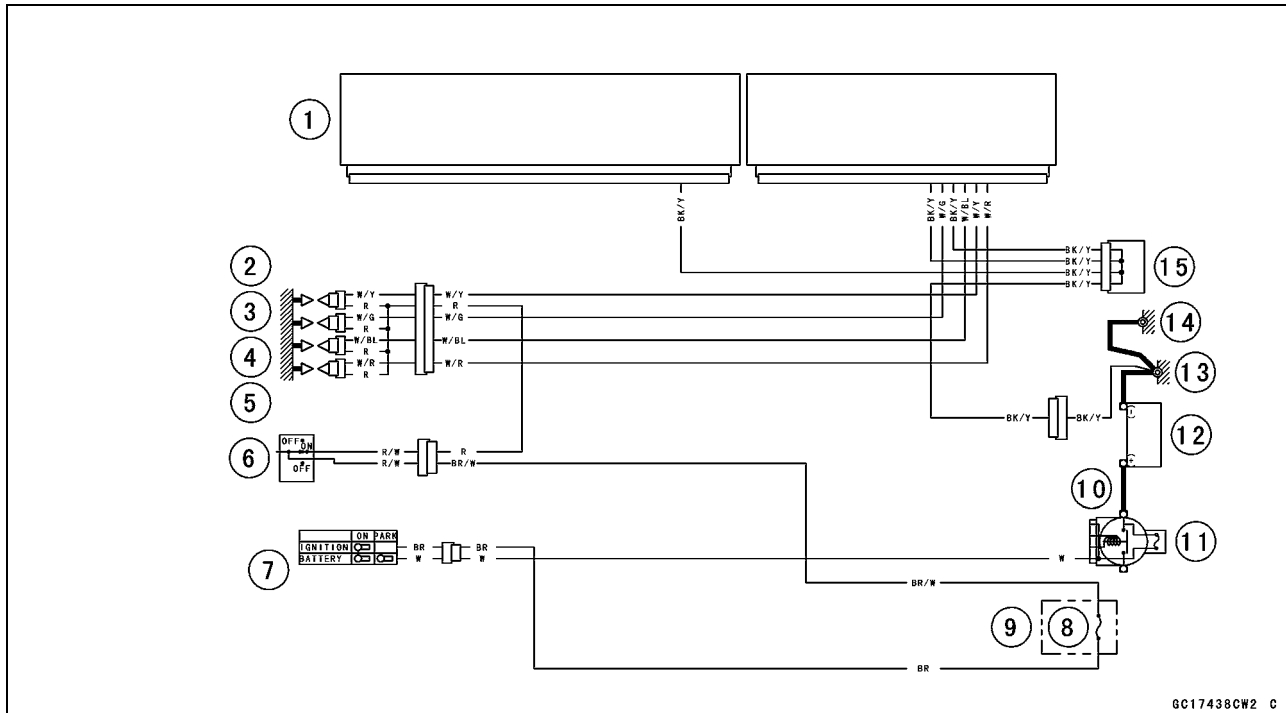

1. ECU
2. Stick Coil #4
3. Stick Coil #3
4. Stick Coil #2
5. Stick Coil #1
6. Engine Stop Switch
7. Ignition Switch
8. Fuse Box 2

9. Ignition Fuse 10 A
10. Starter Relay
11. Main Fuse 30 A
12. Battery 12 V 14 Ah
13. Frame Ground 2
14. Engine Ground
15. Joint Connector 3

Subthrottle Valve Actuator (Service Code 62)

Subthrottle Valve Actuator Removal

CAUTION
<p>Do not remove the subthrottle valve actuator [A] since it has been adjusted and set with precision at the factory.</p> <p>Never drop the actuator, especially on a hard surface. Such a shock to the actuator can damage it.</p>



Subthrottle Valve Actuator Inspection

- Remove:
 - Fuel Tank (see Fuel Tank Removal)
 - Left and Right Air Cleaner Caps (see Throttle Body Assy Removal)
- Turn the ignition switch ON.
- Check to see that all subthrottle valves [A] open and close smoothly.
- ★ If the subthrottle valves do not operate, check the actuator internal resistance (see Resistance Inspection).

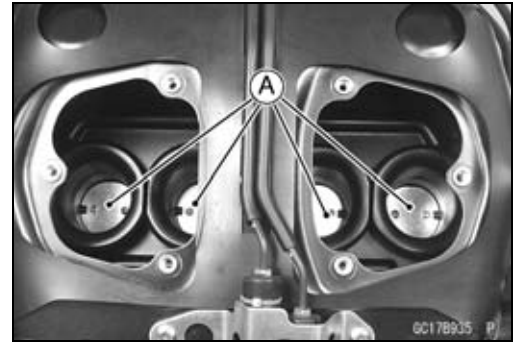

Resistance Inspection

- Turn the ignition switch OFF.
- Disconnect the subthrottle valve actuator connector [A].

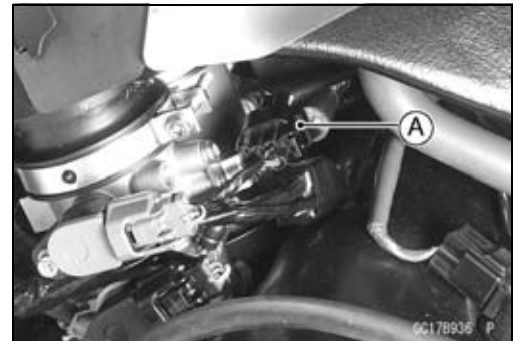

- Connect a digital meter to the connector [A].
- Measure the subthrottle valve actuator resistance.

Subthrottle Valve Actuator Resistance

Connections: Y lead [1] ↔ P lead [2]
 BK lead [3] ↔ G lead [4]

Standard: About 5 ~ 7 Ω

- ★ If the reading is out of the range, replace the throttle body assy (see Throttle Body Assy section).
- ★ If the reading is within the range, check the input voltage (see Input Voltage Inspection in this section).

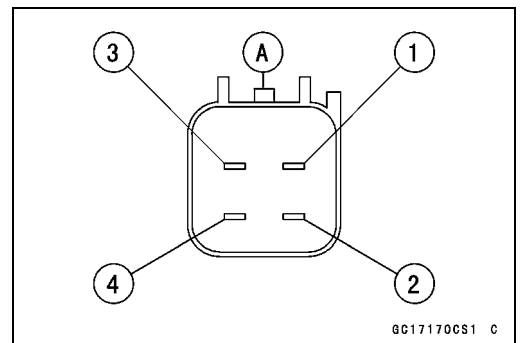

3-88 FUEL SYSTEM (DFI)

Subthrottle Valve Actuator (Service Code 62)

Input Voltage Inspection

NOTE

○Be sure the battery is fully charged.

- Turn the ignition switch OFF.
- Connect the peak voltage adapter [A] and a digital meter [B] to the connector [C], using the needle adapter set [D].

Special Tools - Peak Voltage Adapter: 57001-1415

Type: KEK-54-9-B

Needle Adapter Set: 57001-1457

Subthrottle Valve Actuator Input Voltage Connections to Harness Connector

- (I) Meter (+) → BK/BL lead [1]
Meter (-) → Frame Ground 2 [E]
- (II) Meter (+) → G lead [2]
Meter (-) → Frame Ground 2 [E]
- (III) Meter (+) → Y/BK lead [3]
Meter (-) → Frame Ground 2 [E]
- (IV) Meter (+) → P lead [4]
Meter (-) → Frame Ground 2 [E]

- Measure the input voltage with the engine stopped, and with the connector joined.
- Turn the ignition switch ON.

Input Voltage

Standard: About DC 10.5 ~ 12.5 V

- ★ If the reading is out of the range, check the wiring to ECU (see wiring diagram in this section).
- ★ If the wiring is good, replace the ECU (see ECU section).

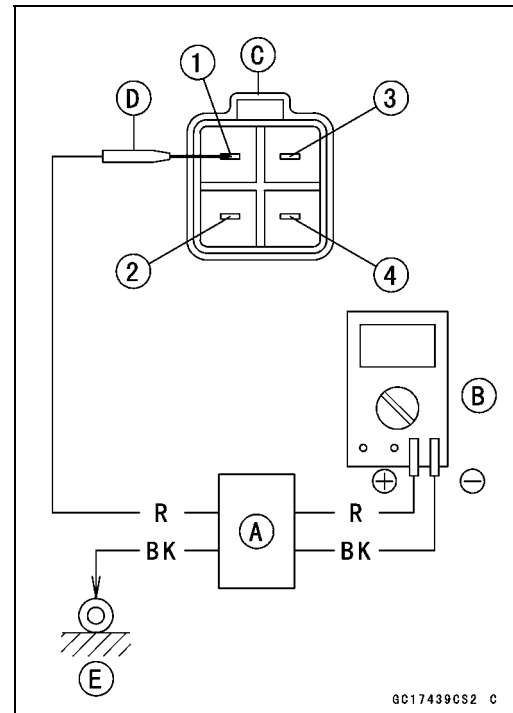

Subthrottle Valve Actuator (Service Code 62)

Subthrottle Valve Actuator Circuit

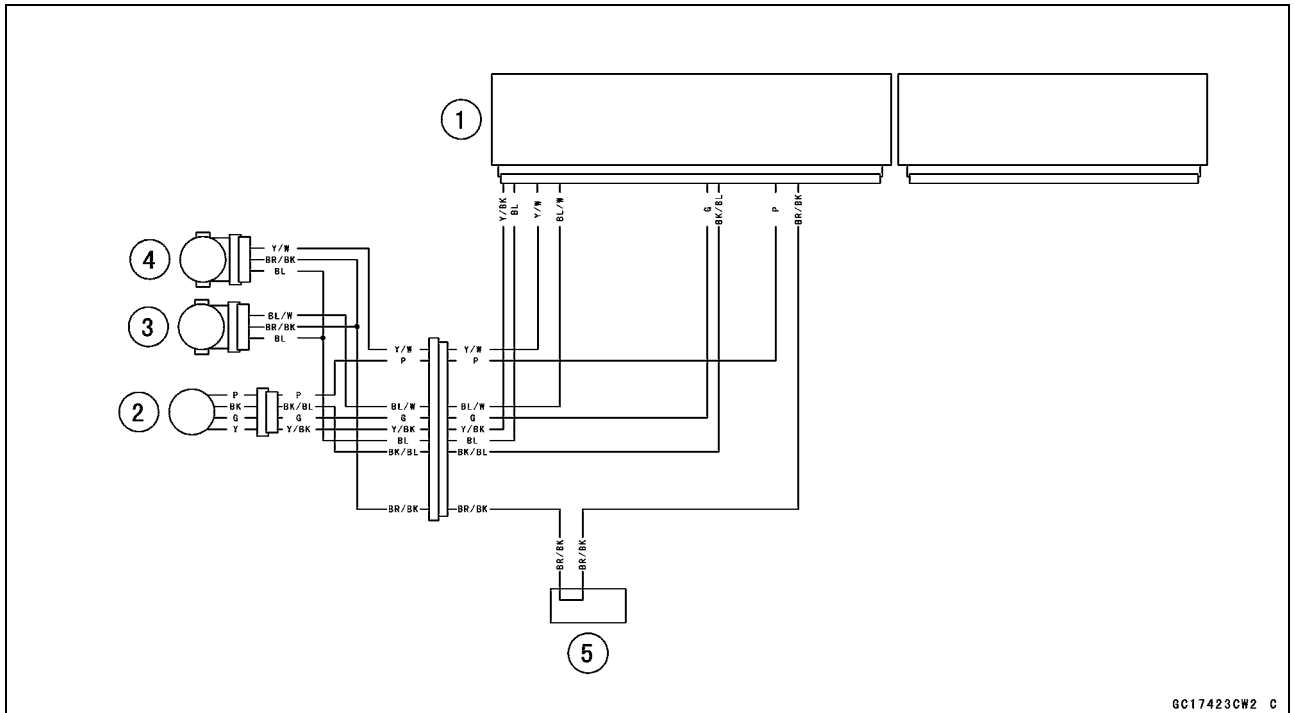

GC17423CW2 C

1. ECU
2. Subthrottle Valve Actuator
3. Subthrottle Sensor
4. Main Throttle Sensor
5. Water-proof Joint 2

3-90 FUEL SYSTEM (DFI)

ECU Main Relay (Service Code 75)

ECU Main Relay Inspection

- The ECU main relay function is included in the ECU [A].
So, the ECU main relay function cannot be inspected.
- When the service code 75 is displayed on the LCD, replace the ECU (see ECU section).

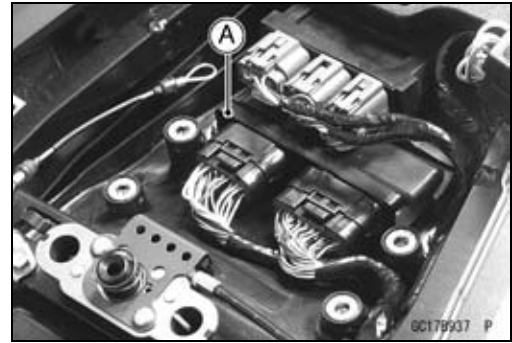

ECU

CAUTION

Never drop the ECU, especially on a hard surface. Such a shock to the ECU can damage it.

ECU Identification

○Most countries have their own regulations, so each ECU has different characteristic. So, do not confuse ECU with each other and use only the ECU for your model. Otherwise, the motorcycle cannot clear the regulation.

ECU Identification

Part Number [A]	Specification
21175-0076	Europe, WVTA, Full, H, with Immobilizer
	U.K., WVTA, Full, H, with Immobilizer
21175-0084	U.S.A (except California), without Immobilizer
	Canada, without Immobilizer
21175-0089	U.S.A (California), without Immobilizer
21175-0101	Malaysia, with Immobilizer
21175-0090	Australia, with Immobilizer
21175-0102	France, WVTA, 78.2, H, with Immobilizer

Full: Full Power

H: Honeycomb Type Catalyst

78.2: Maximum Horsepower 78.2 kW (106.3 PS)

ECU Removal

- Remove the seat (see Seat Removal in the Frame chapter).
- Pull the hook [A] to lift up the lid [B] of the tool kit case.

- Remove the tool kit [A].

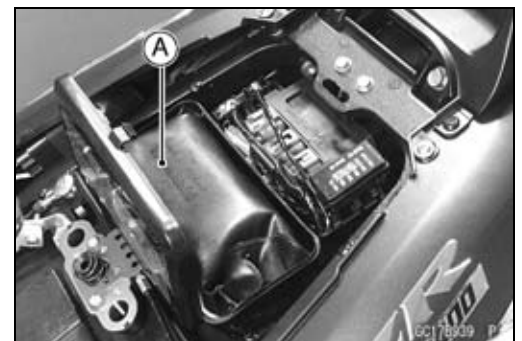
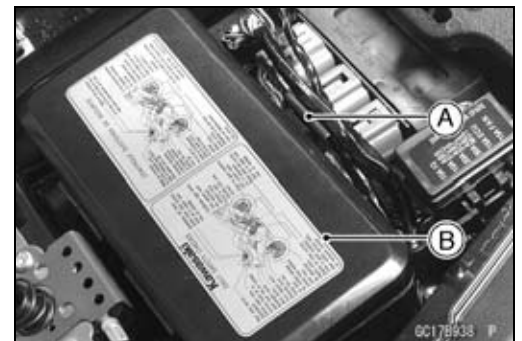
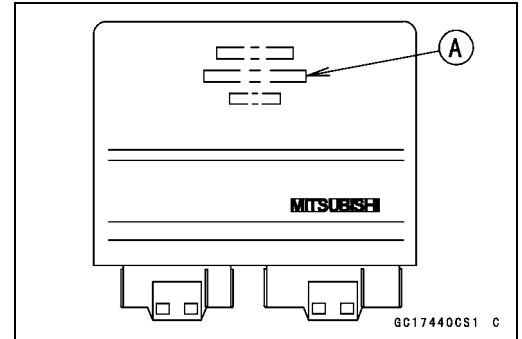

3-92 FUEL SYSTEM (DFI)

ECU

- Remove:
 - Fuse Box [A]
 - Bolts [B]
 - Tool Kit Case [C]

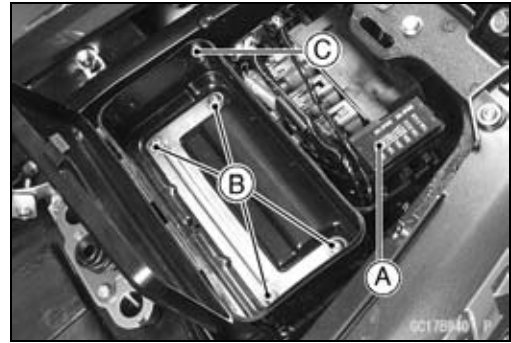

- Remove the relay box [A].
- Lift up the ECU [B] with rubber protector [C].

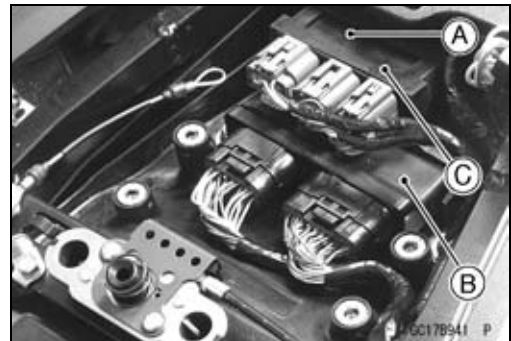

- Remove:
 - ECU Connectors [A]
 - ECU [B]
- Refer to the Immobilizer System Parts Replacement in the Electrical System chapter for the immobilizer models (see Immobilizer System Parts Replacement in the Electrical System chapter).

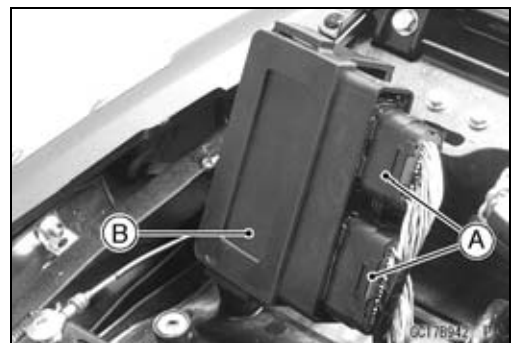

ECU Installation

- Install:
 - ECU [A] (In rubber protector [B])
 - ECU Connectors [C]

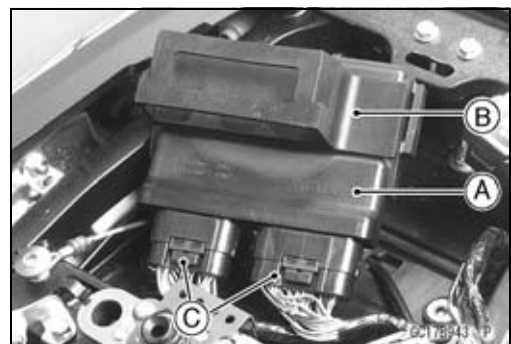

- Insert the slits of the rubber protector to the projections [A] of the rear fender front.

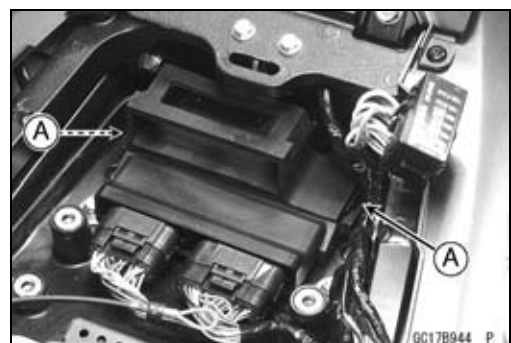

ECU

- Install:
Connector Holder [A]
Relay Box [B]

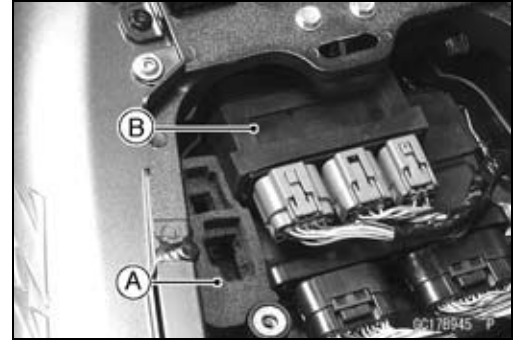

- Install the plate [A] to the tool kit case [B] and tighten the bolts [C].
- Insert the stopper [D] of the fuse box [E] into the groove of the tool case.

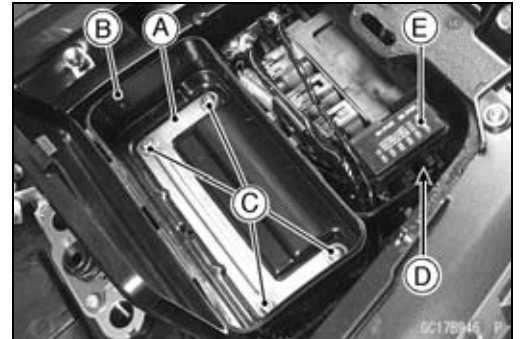

ECU Power Supply Inspection

- Remove the ECU (see ECU Removal).
- Visually inspect the terminals [A] of the ECU connectors.
- ★ If the connector is clogged with mud or dust, blow it off with compressed air.
- ★ Replace the main harness if the terminals of the main harness connectors are cracked, bent, or otherwise damaged.
- ★ Replace the ECU if the terminals of the ECU connectors are cracked, bent, or otherwise damaged.

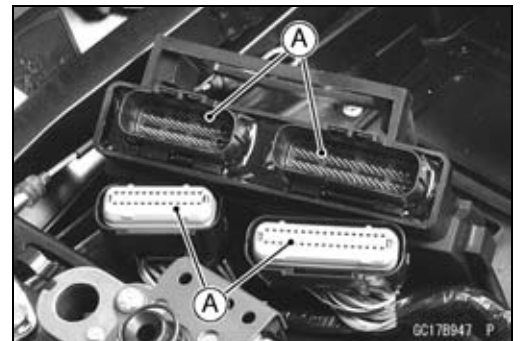

- With the ECU connectors [B] connected, check the following ground lead for continuity with the ignition switch OFF, using a digital meter [A] and needle adapter set.

Special Tool - Needle Adapter Set: 57001-1457

ECU Grounding Inspection

17, 39, or 52 Terminal ↔ Frame Ground 2 [C]: 0 Ω
 Engine Ground ↔ Frame Ground 2 [C]: 0 Ω

- ★ If no continuity, check the connector, the engine ground lead, or main harness, and repair or replace them if necessary.

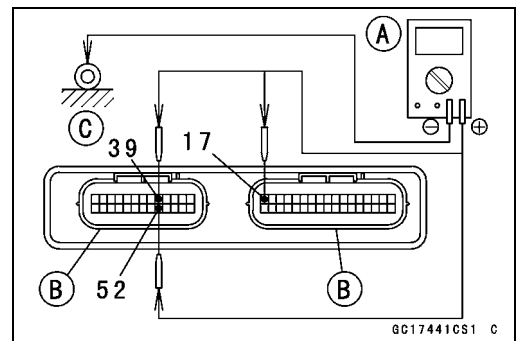

3-94 FUEL SYSTEM (DFI)

ECU

- Check the ECU power source voltage with a digital meter [A].
- Position the terminal in accordance with terminal numbers of ECU connectors [B] in the figure.

ECU Power Source Inspection

Tester

- Connections:**
- between 33 (BR) Terminal and Frame Ground 2 [C]
 - between 15 (W/BK) Terminal and Frame Ground 2 [C]
 - between 32 (W/BK) and Frame Ground 2 [C]

- Ignition Switch OFF:**
- 33 (BR) Terminal, 0 V
 - 15 (W/BK) Terminal, Battery Voltage
 - 32 (W/BK) Terminal, Battery Voltage

- Ignition Switch ON:**
- 33 (BR) Terminal, Battery Voltage
 - 15 (W/BK) Terminal, Battery Voltage
 - 32 (W/BK) Terminal, Battery Voltage

- ★ If the tester does not read as specified, check the following.
 - Power Source Wiring (see wiring diagram in this section)
 - Main Fuse 30 A (see Fuse Inspection in the Electrical System chapter)
 - ECU Fuse 15 A (see ECU Fuse Inspection)
- ★ If the wiring and fuse are good, replace the ECU (see ECU section).

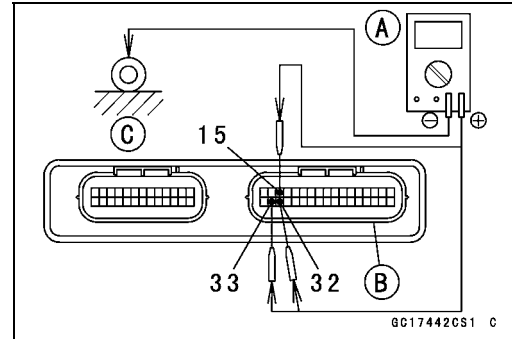

ECU

ECU Power Source Circuit

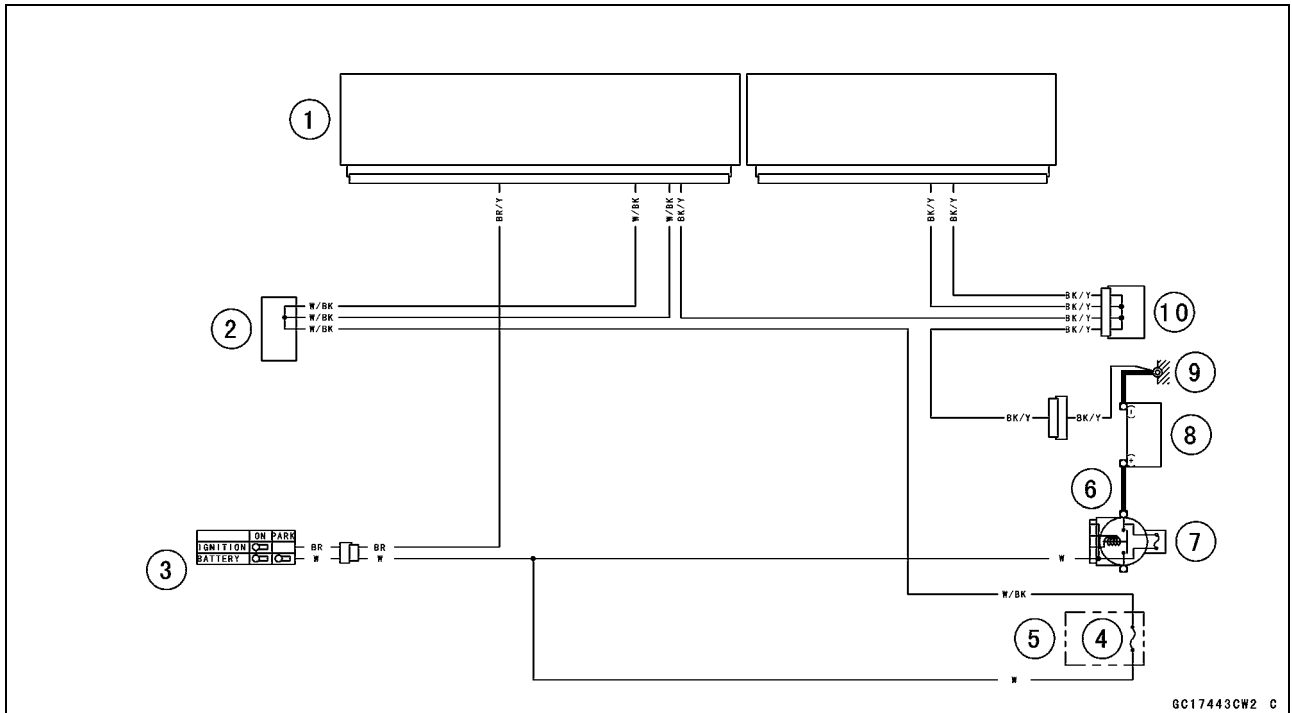

1. ECU
2. Water-proof Joint 1
3. Ignition Switch
4. ECU Fuse 15 A
5. Fuse Box 2
6. Starter Relay
7. Main Fuse 30 A
8. Battery 12 V 14 Ah
9. Frame Ground 2
10. Joint Connector 3

CAN Communication Line Resistance Inspection

○ In this model, resistors for CAN communication line are built in the ECU and meter unit.

- Turn the ignition switch OFF.
- Disconnect the ECU connector [A] (see ECU Removal).



3-96 FUEL SYSTEM (DFI)

ECU

- Connect a digital meter [A] to the ECU connector [B].
- Measure the resistance of the CAN communication line resistor.

CAN Communication Line Resistance (at ECU Connector)

Connections: Terminal 1 ↔ Terminal 18

Standard: 114 ~ 126 Ω

- ★ If the reading is out of the range, replace the ECU (see ECU section).
- ★ If the reading is within the range, resistor of the ECU for CAN communication line is normal.
- Check the wiring for continuity of the CAN communication line (see wiring diagram in this section).
- ★ If the wiring is open, replace the main harness.
- Refer to the Meter Unit Inspection in the Electrical System chapter for the resistor in the meter unit (see Meter Unit Inspection in the Electrical System chapter).

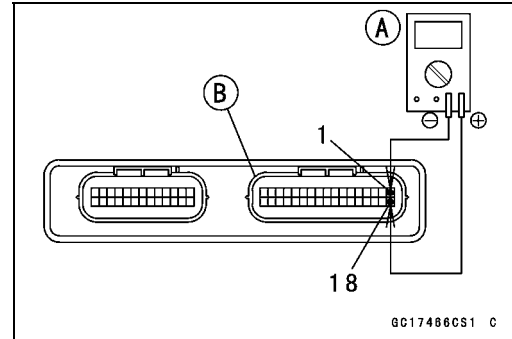

CAN Communication Line Circuit

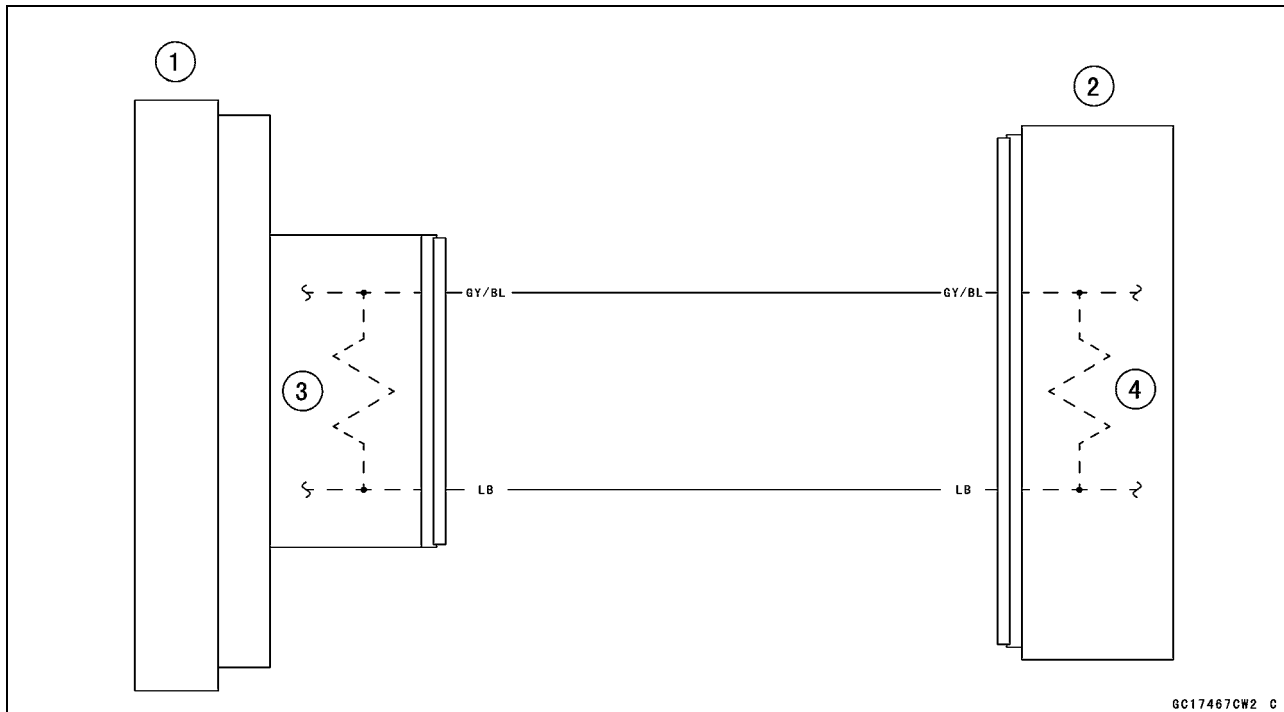

1. Meter Unit
2. ECU
3. Resistor (In the Meter Unit)
4. Resistor (In the ECU)

DFI Power Source

ECU Fuse Removal

- Refer to the ECU Fuse 15 A Removal in the Electrical System chapter (see 15 A ECU Fuse Removal in the Electrical System chapter).

ECU Fuse Installation

- ★ If a fuse fails during operation, inspect the DFI system to determine the cause, and then replace it with a new fuse of proper amperage.
- Refer to the Fuse installation in the Electrical System chapter (see Fuse Installation in the Electrical System chapter).

ECU Fuse Inspection

- Refer to the Fuse Inspection in the Electrical System chapter (see Fuse Inspection in the Electrical System chapter).

3-98 FUEL SYSTEM (DFI)

Warning Indicator Light (LED)

Light (LED) Inspection

- The warning indicator light (LED) [A] is used for the FI indicator and immobilizer indicator (immobilizer models).
- In this model, the warning indicator light (LED) goes on or blinks by the special signal sent from the ECU.
- Refer to the fuel level warning inspection procedure (see Meter Unit Inspection in the Electrical System chapter) for the warning indicator light (LED) inspection.

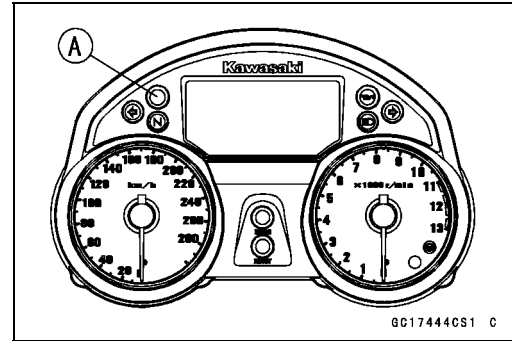

Warning Indicator Light (LED) Circuit

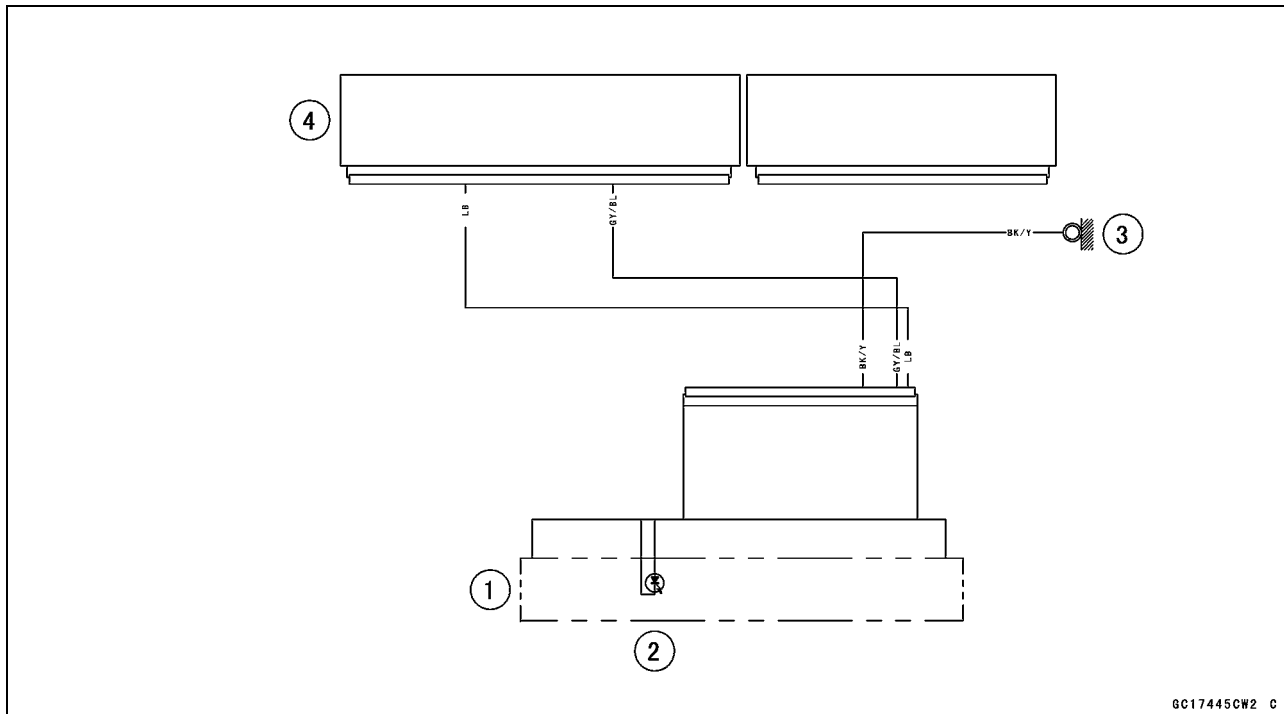

1. Meter Unit
2. Warning Indicator Light (LED)
3. Frame Ground 1
4. ECU

Fuel Line

Fuel Pressure Inspection

NOTE

○ Be sure the battery is fully charged.

- Remove the fuel tank (see Fuel Tank Removal).
- Be sure to place a piece of cloth around the fuel supply pipe of the throttle body assy.
- Remove the fuel hose from the fuel supply pipes of the throttle body assy (see Fuel Hose Replacement in the Periodic Maintenance chapter).

⚠ WARNING

Be prepared for fuel spillage; any spilled fuel must be completely wiped up immediately. When the fuel hose is disconnected, fuel spills out from the hose and the pipe because of residual pressure. Cover the hose connection with a piece of clean cloth to prevent fuel spillage.

- Connect the following parts temporary.
Fuel Pump Lead Connector
Fuel Level Sensor Lead Connector
- Install the fuel pressure gauge adapter [A] and fuel hoses (Special Tool: 57001-1607) [B] between the fuel supply pipes of the fuel pump and throttle body assy.
- Connect the pressure gauge [C] to the fuel pressure gauge adapter.

**Special Tools - Oil Pressure Gauge, 5 kgf/cm²: 57001-125
Fuel Pressure Gauge Adapter: 57001-1593
Fuel Hose: 57001-1607**

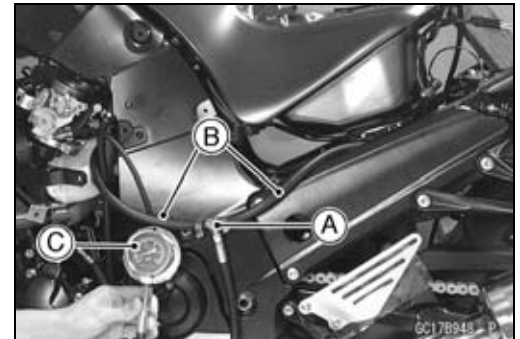

⚠ WARNING

Do not try to start the engine with the fuel hoses disconnected.

- Turn the ignition switch ON. The fuel pump will turn for 3 seconds, and then stop.

CAUTION

Do not drive the fuel pump 3 seconds or more without the fuel in the fuel tank. If the fuel pump is driven without the fuel, it may be damaged.

- Measure the fuel pressure with the engine stopped.

Fuel Pressure

right after Ignition Switch ON, with pump running:

Standard: 304 kPa (3.1 kgf/cm², 44 psi)

after 3 seconds from Ignition Switch ON, with pump stopped:

Standard: 280 kPa (2.9 kgf/cm², 41 psi) , residual fuel pressure

The system should hold the residual pressure about 30 seconds.

3-100 FUEL SYSTEM (DFI)

Fuel Line

- Start the engine, and let it idle.
- Measure the fuel pressure with the engine idling.

Fuel Pressure (idling)

Standard: 304 kPa (3.1 kgf/cm², 44 psi)

NOTE

○The gauge hand will fluctuate. Read the pressure at the average of the maximum and minimum indications.

- ★ If the fuel pressure is much higher than the specified, replace the fuel pump (see Fuel Pump section).
- ★ If the fuel pressure is much lower than specified, check the following.
 - Fuel Line Leakage
 - Amount of Fuel Flow (see Fuel Flow Rate Inspection)
- ★ If the fuel pressure is much lower than specified, and if inspection above checks out good, replace the throttle body assy, or the fuel pump and measure the fuel pressure again (see appropriate sections).
- Remove the fuel pressure gauge, hoses and adapter.
- Install:
 - Fuel Hose (see Fuel Hose Replacement in the Periodic Maintenance chapter)
 - Fuel Tank (see Fuel Tank Installation)

Fuel Flow Rate Inspection

NOTE

○Be sure the battery is fully charged.

⚠ WARNING

Gasoline is extremely flammable and can be explosive under certain conditions. Make sure the area is well-ventilated and free from any source of flame or sparks; this includes any appliance with a pilot light. Do not smoke. Turn the ignition switch OFF. Be prepared for fuel spillage; any spilled fuel must be completely wiped up immediately.

- Turn the ignition switch and engine stop switch OFF.
- Wait until the engine cools down.
- Prepare a fuel hose (Special Tool: 57001-1607) and a measuring cylinder.

Special Tool - Fuel Hose: 57001-1607

- Remove:
 - Seat (see Seat Removal in the Frame chapter)
 - Fuel Tank Cover (see Fuel Tank Removal)
 - Fuel Tank Bolts [A]



Fuel Line

- Remove the fuel tank bolts [A].



- Open the fuel tank cap [A] to lower the pressure in the tank.
- Be sure to place a piece of cloth around the fuel supply pipe of the fuel pump.
- Remove the fuel hose from the fuel pump (see Fuel Tank Removal).



⚠ WARNING

Be prepared for fuel spillage; any spilled fuel must be completely wiped up immediately. When the fuel hose is disconnected, fuel spills out from the hose and the pipe because of residual pressure. Cover the hose connection with a piece of clean cloth to prevent fuel spillage.

- Connect the prepared fuel hose [A] to the fuel supply pipe of the fuel pump.
- Secure the fuel hose with a clamp.
- Insert the fuel hose into the measuring cylinder [B].

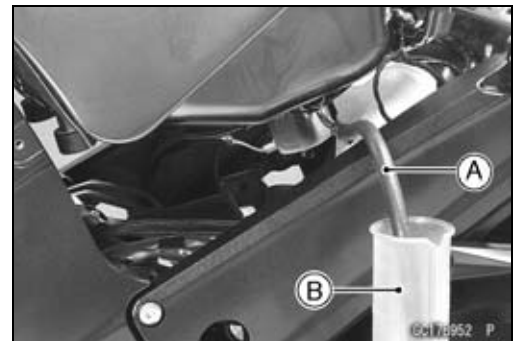

3-102 FUEL SYSTEM (DFI)

Fuel Line

WARNING

**Wipe off spilled out fuel immediately.
Be sure to hold the measuring cylinder vertical.**

- Close the fuel tank cap.
- With the engine stopped, turn the ignition switch ON. The fuel pump should operate for 3 seconds, and then should stop.

CAUTION

Do not drive the fuel pump 3 seconds or more without the fuel in the fuel tank. If the fuel pump is driven without the fuel, it may be damaged.

- Measure the discharge for 3 seconds.
- Repeat this operation several times.

Amount of Fuel Flow

Standard: 67 mL (2.26 US oz.) or more for 3 seconds

- ★ If the fuel flow is much less than the specified, check the following.

Battery Condition (see Charging Condition Inspection in the Electrical System chapter)

- After inspection, connect the fuel hose (see Fuel Tank Installation).
- Start the engine and check for fuel leakage.

Fuel Pump

Fuel Pump Removal

CAUTION

Never drop the fuel pump, especially on a hard surface. Such a shock to the pump can damage it.

⚠ WARNING

Gasoline is extremely flammable and can be explosive under certain conditions. Make sure the area is well-ventilated and free from any source of flame or sparks; this includes any appliance with a pilot light. Do not smoke. Turn the ignition switch OFF. Disconnect the battery (-) terminal.

To make fuel spillage minimum, draw the fuel out from the fuel tank when the engine is cold. Be prepared for fuel spillage; any spilled fuel must be completely wiped up immediately.

- Draw the fuel out from the fuel tank with a commercially available electric pump.
- Remove the fuel tank (see Fuel Tank Removal).
- Be careful of fuel spillage from the fuel tank since fuel still remains in the fuel tank and fuel pump. Plug the fuel pipe of the fuel tank.
- Turn the fuel tank upside down.
- Unscrew the fuel pump bolts [A], and take out the fuel pump assembly [B] and gasket.
- Discard the fuel pump gasket.

CAUTION

Do not pull the leads [C] of the fuel pump and fuel reserve switch. If they are pulled, the lead terminals may be damaged.

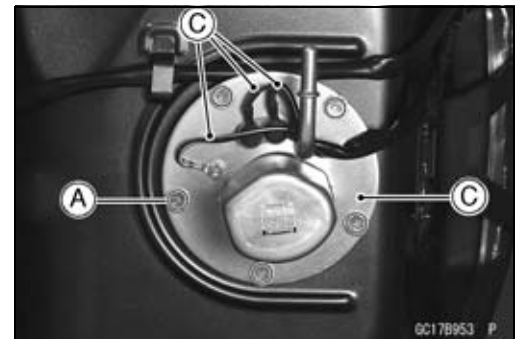

Fuel Pump Installation

- Remove dirt or dust from the fuel pump [A] by lightly applying compressed air.
- Replace the fuel pump gasket with a new one.

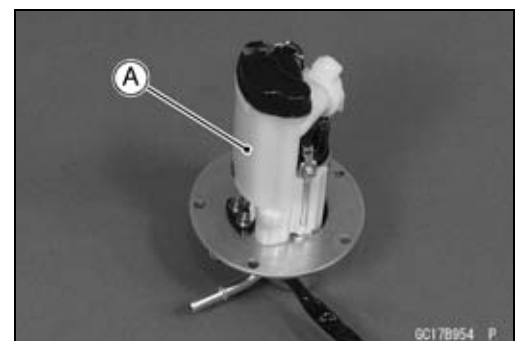

3-104 FUEL SYSTEM (DFI)

Fuel Pump

- Check that the fuel pump terminals [A], fuel reserve switch terminal [B] and band [C] are in place.
Front [D]
- Apply a non-permanent locking agent to the threads of the fuel pump bolts.
- Tighten the fuel pump bolts to a snug fit following the tightening sequence shown.
- Following the tightening sequence, tighten the pump bolts to the specified torque.

Torque - Fuel Pump Bolts: 9.8 N·m (1.0 kgf·m, 89 in·lb)

- Tighten the pump bolts again to check the tightness in the order shown.

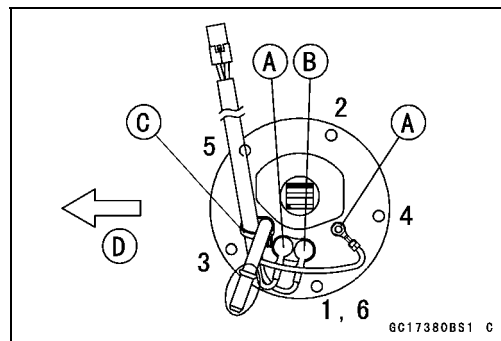

Operation Inspection

NOTE

○Be sure the battery is fully charged.

- Turn the ignition switch ON and make sure that the fuel pump operates (make light sounds) for 3 seconds, and then stops.
- Turn the ignition switch OFF.
- ★ If the pump does not work as described above, inspect the operating voltage.

Operating Voltage Inspection

NOTE

○Be sure the battery is fully charged.

- Turn the ignition switch OFF.
- Remove the seat (see Seat Removal in the Frame chapter).
- Connect the hand tester (× 25 V DC) to the 4 pins connector [A], with needle adapter set.

Special Tools - Hand Tester: 57001-1394

Needle Adapter Set: 57001-1457

Pump Operating Voltage at Pump Connections to Pump Connector

Tester (+) → BK/Y Lead

Tester (-) → BK/W Lead

- Measure the operating voltage with the engine stopped, and with the connector joined.
- Turn the ignition switch ON.
- The tester needle should indicate battery voltage for 3 seconds, and then 0 V.

Operating Voltage at Pump Connector

Standard: Battery Voltage for 3 seconds, and then 0 V

- ★ If the reading stays on battery voltage, and never shows 0 V. Check the ECU and fuel pump relay.
- ★ If the voltage is in specification, but the pump doesn't work, replace the pump.
- ★ If there is still no battery voltage, check the pump relay (see Fuel Pump Relay Inspection).

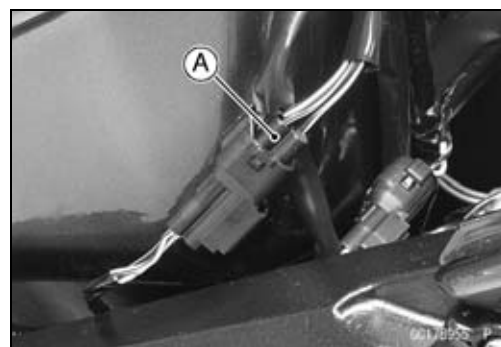

Fuel Pump

Fuel Pump Circuit

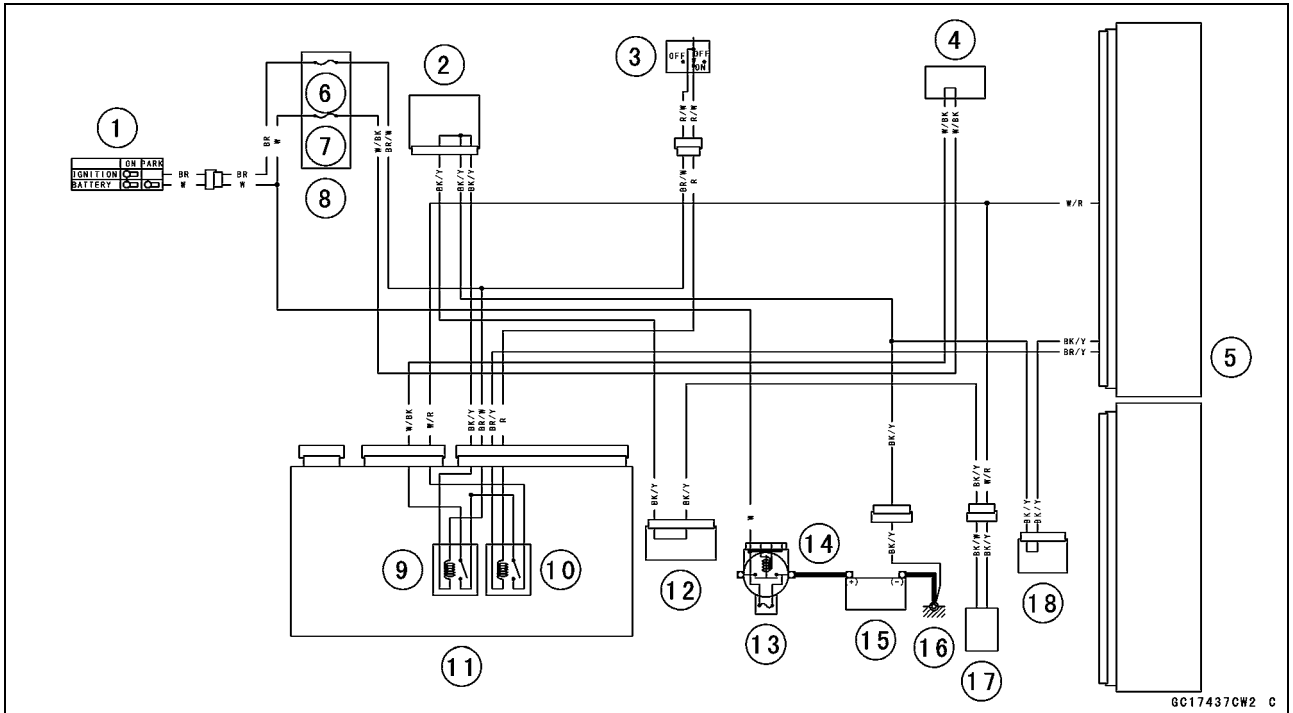

- | | |
|------------------------|------------------------|
| 1. Ignition Switch | 10. Fuel Pump Relay |
| 2. Joint Connector 1 | 11. Relay Box |
| 3. Engine Stop Switch | 12. Joint Connector 2 |
| 4. Water-proof Joint 1 | 13. Main Fuse 30 A |
| 5. ECU | 14. Starter Relay |
| 6. ECU Fuse 15 A | 15. Battery 12 V 14 Ah |
| 7. Ignition Fuse 10 A | 16. Frame Ground 2 |
| 8. Fuse Box 2 | 17. Fuel Pump |
| 9. Main Relay | 18. Joint Connector 3 |

GC17437CW2 C

3-106 FUEL SYSTEM (DFI)

Fuel Injectors

Removal/Installation

- Refer to the Throttle Body Assy Disassembly/Assembly (see Throttle Body Assy Disassembly/Assembly).

CAUTION

Never drop the injector, especially on a hard surface. Such a shock to the injector can damage it.

Power Source Voltage Inspection

NOTE

○ Be sure the battery is fully charged.

- Turn the ignition switch OFF.
- Remove the ECU (see ECU Removal).
- Do not disconnect the ECU connectors.
- Connect a digital meter [A] to the connector [B], with the needle adapter set.

Special Tool - Needle Adapter Set: 57001-1457

Injector Power Source Voltage at ECU Connector Connections to ECU Connector

Meter (+) → W/R lead (terminal 14)

Meter (-) → Frame Ground 2 [C]

- Measure the power source voltage with the engine stopped, and with the connectors joined.
- Turn the ignition switch ON.

Power Source Voltage at ECU

Standard: Battery Voltage for 3 seconds, and then 0 V

- ★ If the power source voltage is less than the standard, check the fuel pump relay (see Fuel Pump Relay Inspection), wiring (see wiring diagram in this section), and the ECU for its ground, and power supply (see ECU Power Supply Inspection chapter).
- ★ If the reading is normal, check the power source voltage at the injector connector.
- Remove:
 - Left Middle Fairing (see Middle Fairing Removal in the Frame chapter)
 - Bolts [A]

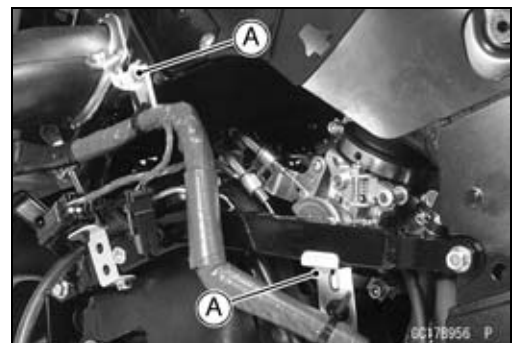
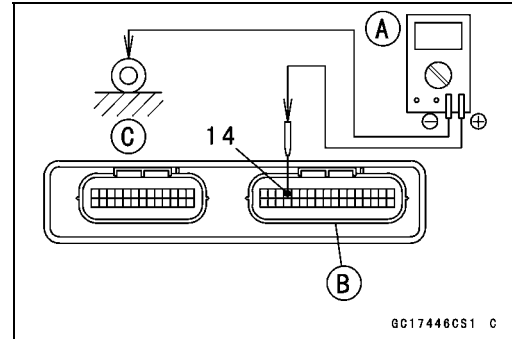

Fuel Injectors

- Connect a digital meter [A] to the throttle body subharness connector [B], using the needle adapter set [C].

Special Tool - Needle Adapter Set: 57001-1457

**Injector Power Source Voltage at Injector
Connections to Injector #1, #2, #3, #4**

Meter (+) → W/R lead [E]

Meter (-) → Ground [D]

- Measure the power source voltage with the engine stopped, and with the connector joined.
- Turn the ignition switch ON.

Power Source Voltage at Injector Connector

Standard: Battery Voltage for 3 seconds, and then 0 V

- Turn the ignition switch OFF.
- ★ If the reading is out of the standard, check the wiring (see wiring diagram in this section).
- ★ If the reading is good, and the power source voltage is normal, check the output voltage.

Output Voltage Inspection

- Measure the output voltage at the ECU connector in the same way as power source voltage inspection. Note the following.

Digital Meter [A]

Connector [B]

Special Tool - Needle Adapter Set: 57001-1457

Injector Output Voltage at ECU

Connections for Injector #1

Meter (+) → BL/R lead (terminal 46)

Meter (-) → Frame Ground 2 [C]

Connections for Injector #2

Meter (+) → BL/G lead (terminal 59)

Meter (-) → Frame Ground 2 [C]

Connections for Injector #3

Meter (+) → BL/BK lead (terminal 44)

Meter (-) → Frame Ground 2 [C]

Connections for Injector #4

Meter (+) → BL/Y lead (terminal 57)

Meter (-) → Frame Ground 2 [C]

- Turn the ignition switch ON.

Output Voltage at ECU

Standard: Battery Voltage for 3 seconds, and then 0 V

- ★ If the output voltage is normal, check the ECU for its ground, and power supply (see ECU Power Supply Inspection).
- ★ If the ground and power supply are good, replace the ECU (see ECU section).

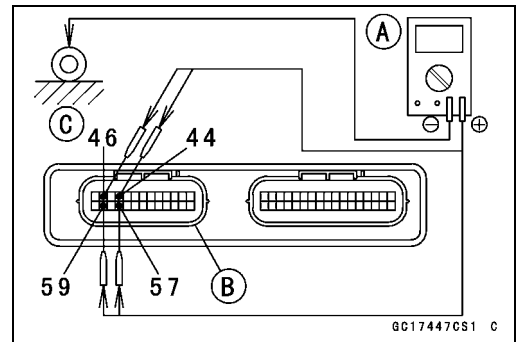
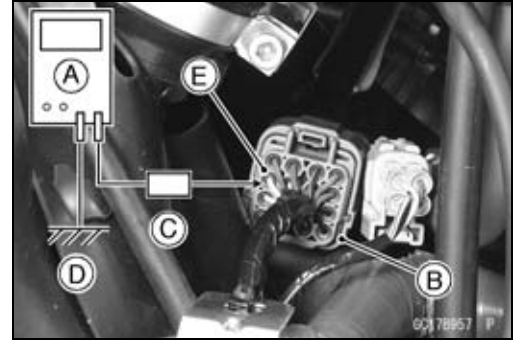

3-108 FUEL SYSTEM (DFI)

Fuel Injectors

★ If the output voltage is out of the standard, check the output voltage at the throttle body subharness connector [B] using a digital meter [A] and needle adapter set [C] (when the lead is open, the output voltage is 0 V).

Special Tool - Needle Adapter Set: 57001-1457

Injector Output Voltage at Injector

Connections to Injector #1

Meter (+) → BL/R lead [E]

Meter (-) → Ground [D]

Connections to Injector #2

Meter (+) → BL/G lead [F]

Meter (-) → Ground [D]

Connections to Injector #3

Meter (+) → BL/BK lead [G]

Meter (-) → Ground [D]

Connections to Injector #4

Meter (+) → BL/Y lead [H]

Meter (-) → Ground [D]

- Turn the ignition switch ON.

Output Voltage at Injector Connector

Standard: Battery Voltage for 3 seconds, and then 0 V

★ If the output voltage is normal, check the wiring for continuity (see wiring diagram in this section).

★ If the wiring is good, perform “Audible Inspection” for confirmation.

★ If the output voltage is out of the standard, perform “Audible Inspection” for confirmation.

Audible Inspection

- Remove the left and right fairing cover (see Fairing Cover Removal in the Frame chapter).
- Start the engine.
- Apply the tip of a screwdriver [A] to the injector [B]. Put the grip end onto your ear, and listen whether the injector is clicking or not.
- A sound scope can also be used.
- Do the same for the other injector.
- ★ If all the injectors click at a regular intervals, the injectors are good.
- The click interval becomes shorter as the engine speed rises.
- ★ If either injector doesn't click, perform the “Injector Signal Test” for injector operation.

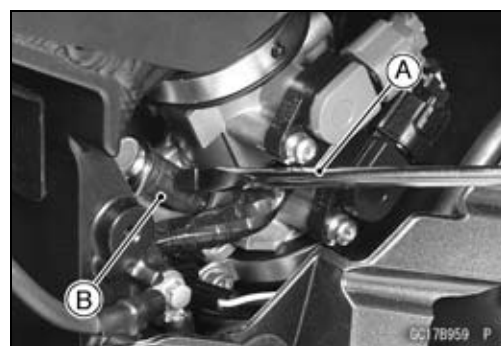
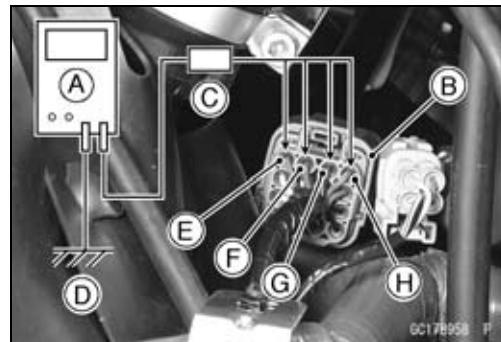

Fuel Injectors

Injector Signal Test

- Prepare two test light sets with male terminals as shown.
 Rating of Bulb [A]: 12 V × 3 ~ 3.4 W
 Terminal Width [B]: 1.8 mm (0.07 in.)
 Terminal Thickness [C]: 0.8 mm (0.03 in.)

CAUTION

Do not use larger terminals than specified above. A larger terminal could damage the injector main harness connector (female), leading to harness repair or replacement.

Be sure to connect bulbs in series. The bulb works as a current limiter to protect the solenoid in the injector from excessive current.

- Disconnect the connectors for injector [A].
- Connect each test light set [B] to the injector sub harness connector [C].
- Turn the ignition switch ON.
- While cranking the engine with the starter motor, watch the test lights.
- ★ If the test lights flicker at regular intervals, the injector circuit in the ECU, and the wiring are good. Perform the "Injector Resistance Inspection".

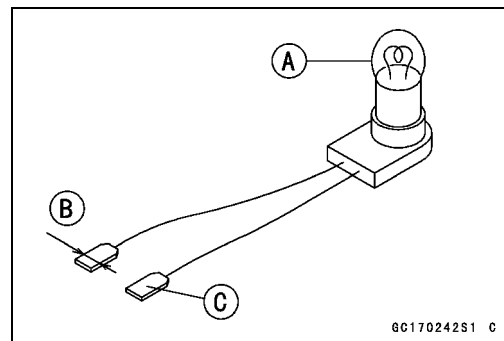

6C170242S1 C

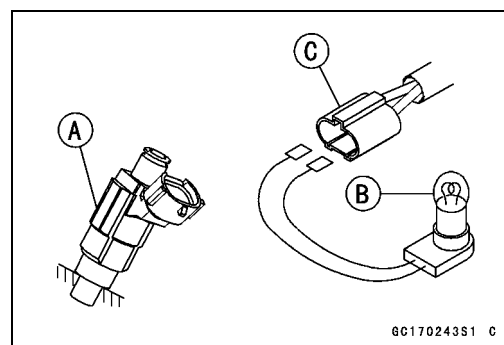

6C170243S1 C

○ Injector signals can be also confirmed by connecting the hand tester (× 10 V AC) instead of the test light set to the injector main harness (female) connector. Crank the engine with the starter motor, and check to see if the hand oscillates at regular intervals.

Special Tool - Hand Tester: 57001-1394

- ★ If the test light does not flicker (or the test hand doesn't oscillates), check the wiring and connectors again.
- ★ If the wiring is good, replace the ECU (see ECU section).

Injector Resistance Inspection

- Remove the throttle body assy (see Throttle Body Assy Removal).
- Disconnect the connector from the injector [A] (see Throttle Body Disassembly/Assembly).
- Measure the injector resistance with a digital meter.

Injector Resistance

Connections to Injector

Meter (+)		Meter (-)
#1: W/R	↔	BL/R Terminal
#2: W/R	↔	BL/G Terminal
#3: W/R	↔	BL/BK Terminal
#4: W/R	↔	BL/Y Terminal

Standard: about 11.7 ~ 12.3 Ω at 20°C (68°F)

- ★ If the reading is out of the range, perform the "Injector Unit Test".
- ★ If the reading is normal, perform the "Injector Unit Test" for confirmation.



3-110 FUEL SYSTEM (DFI)

Fuel Injectors

Injector Unit Test

- Use two leads [A] and the same test light set [B] as in "Injector Signal Test".
Rating of Bulb [C]: 12 V × (3 ~ 3.4) W
12 V MF Battery [D]

CAUTION

Be sure to connect the bulb in series. The bulb works as a current limiter to protect the solenoid in the injector from excessive current.

- Connect the test light set to the injector [E] as shown.
- Open and connect [F] the end of the lead to the battery (-) terminal repeatedly. The injector should click.
- ★ If the injector does not click, replace the injector.

Injector Fuel Line Inspection

- Remove the throttle body assy (see Throttle Body Assy Removal).
- Check the injector fuel line for leakage as follows.
 - Connect a commercially available vacuum/pressure pump [A] to the nipple of the delivery pipe [B] with the fuel hose [C] (both ends connected with the clamps [D]) as shown.
 - Apply soap and water solution to the areas [E] as shown.
 - Watching the pressure gauge, squeeze the pump lever [F], and build up the pressure until the pressure reaches the maximum pressure.

Fuel Line Maximum Pressure

Standard: 300 kPa (3.06 kgf/cm², 43 psi)

CAUTION

During pressure testing, do not exceed the maximum pressure for which the system is designed.

- Watch the gauge for at least 6 seconds.
- ★ If the pressure holds steady, the system is good.
- ★ If the pressure drops at once, or if bubbles are found in the area, the line is leaking. Replace the delivery pipe, injectors and related parts.
- Repeat the leak test, and check the fuel line for no leakage.
- Install the throttle body assy (see Throttle Body Assy Installation).
- Run the hoses correctly (see Cable, Wire, and Hose Routing section in the Appendix chapter).

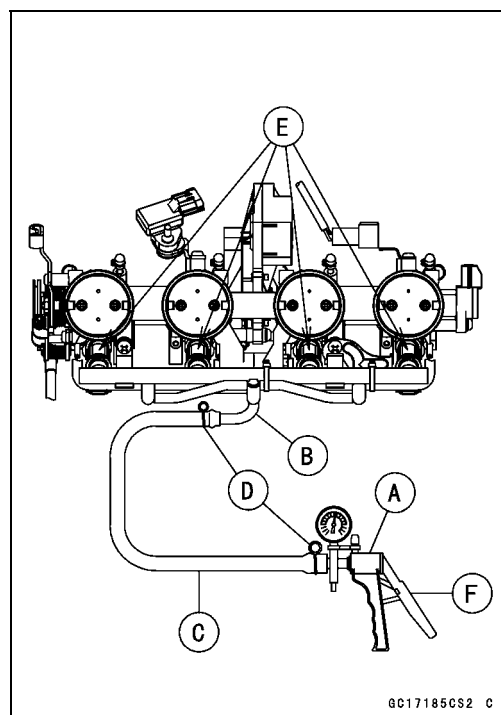
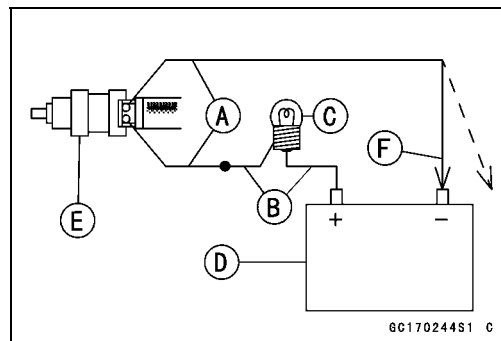

Fuel Injectors

Fuel Injector Circuit

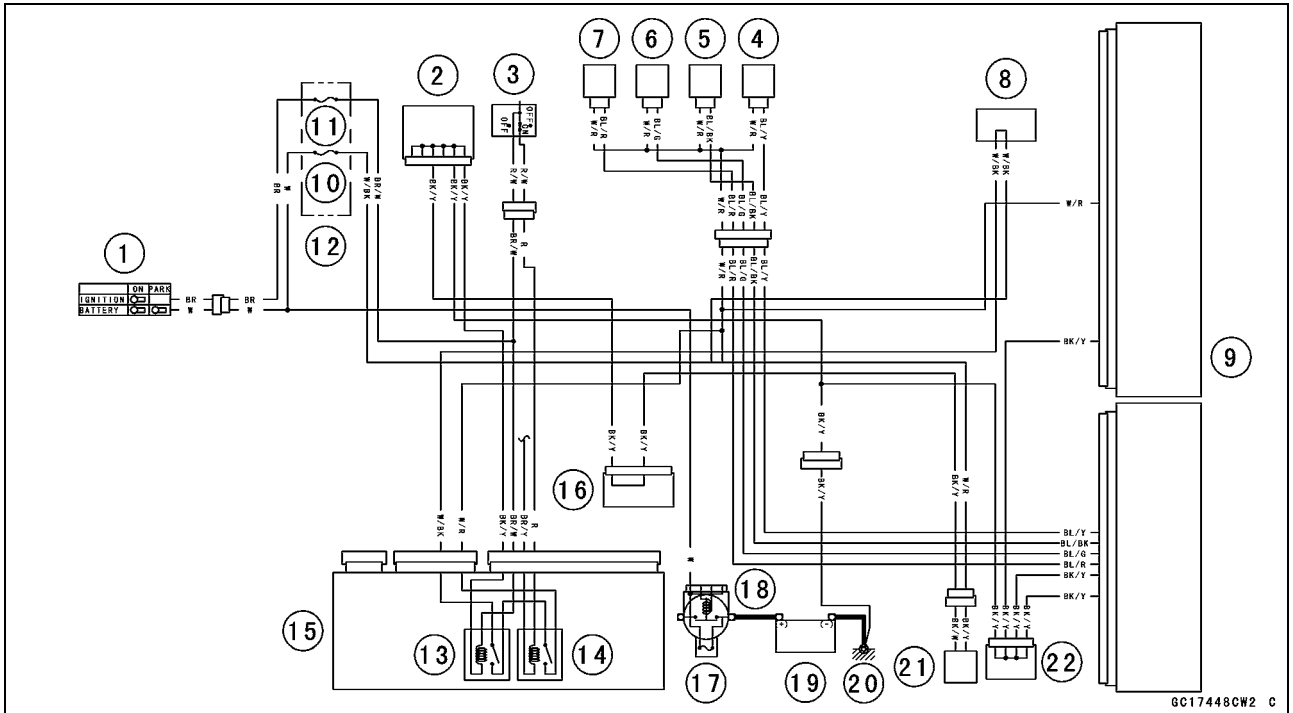

GC17448CW2 C

- | | |
|------------------------|------------------------|
| 1. Ignition Switch | 12. Fuse Box 2 |
| 2. Joint Connector 1 | 13. Main Relay |
| 3. Engine Stop Switch | 14. Fuel Pump Relay |
| 4. Fuel Injector #4 | 15. Relay Box |
| 5. Fuel Injector #3 | 16. Joint Connector 2 |
| 6. Fuel Injector #2 | 17. Main Fuse 30 A |
| 7. Fuel Injector #1 | 18. Starter Relay |
| 8. Water-proof Joint 1 | 19. Battery 12 V 14 Ah |
| 9. ECU | 20. Frame Ground 2 |
| 10. ECU Fuse 15 A | 21. Fuel Pump |
| 11. Ignition Fuse 10 A | 22. Joint Connector 3 |

3-112 FUEL SYSTEM (DFI)

Throttle Grip and Cables

Free Play Inspection

- Refer to the Throttle Control System Inspection in the Periodic Maintenance chapter (see Throttle Control System Inspection in the Periodic Maintenance chapter).

Free Play Adjustment

- Refer to the Throttle Control System Inspection in the Periodic Maintenance chapter (see Throttle Control System Inspection in the Periodic Maintenance chapter).

Cable Installation

- Install the throttle cables in accordance with the Cable , Wire, and Hose Routing section in the Appendix chapter.
- Install the lower ends of the throttle cables in the cable bracket on the throttle assy after installing the upper ends of the throttle cables in the grip.
- After installation, adjust each cable properly (see Throttle Control System Inspection in the Periodic Maintenance chapter).

⚠ WARNING

Operation with incorrectly routed or improperly adjusted cables could result in an unsafe riding condition.

Cable Lubrication

- Refer to the Chassis Parts Lubrication Perform in the Periodic Maintenance chapter (see Chassis Parts Lubrication Perform in the Periodic Maintenance chapter).

Throttle Body Assy

Idle Speed Inspection

- Refer to the Idle Speed Inspection in the Periodic Maintenance chapter (see Idle Speed Inspection in the Periodic Maintenance chapter).

Throttle Bore Cleaning

- Check the throttle bore for cleanliness as follows.
 - Remove the throttle body assy (see Throttle Body Assy Removal).
 - Check the main throttle valves and throttle bores [A] for carbon deposits by opening the main throttle valves.
 - ★ If any carbon accumulates, wipe the carbon off the throttle bores around the throttle bores and the throttle valves, using a cotton pad penetrated with a high-flash point solvent.

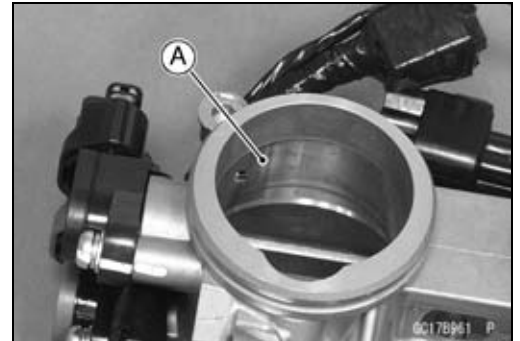

Synchronization Inspection

- Refer to the Engine Vacuum Synchronization Inspection in the Periodic Maintenance chapter (see Engine Vacuum Synchronization Inspection in the Periodic Maintenance chapter).

Synchronization Adjustment

- Refer to the Engine Vacuum Synchronization Inspection in the Periodic Maintenance chapter (see Engine Vacuum Synchronization Inspection in the Periodic Maintenance chapter).

Throttle Body Assy Removal

⚠ WARNING

Gasoline is extremely flammable and can be explosive under certain conditions. Turn the ignition switch OFF. Disconnect the battery (–) cable terminal. Do not smoke. Make sure the area is well-ventilated and free from any source of flame or sparks; this includes any appliance with a pilot light.

Be prepared for fuel spillage: any spilled fuel must be completely wiped up immediately.

- Remove:
 - Fuel Tank Cover (see Fuel Tank Removal)
 - Left and Right Middle Fairings (see Middle Fairing Removal in the Frame chapter)
 - Bolts [A]
 - Subframe Bolts [B] and Washers

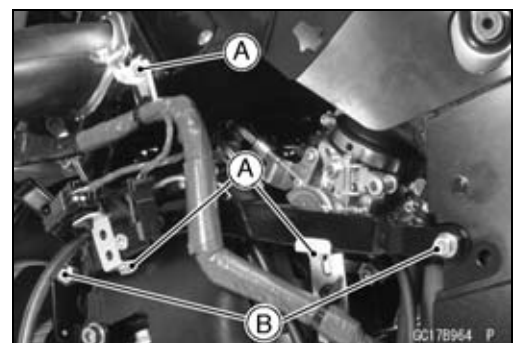

3-114 FUEL SYSTEM (DFI)

Throttle Body Assy

- Disconnect the throttle body subharness connector [A].

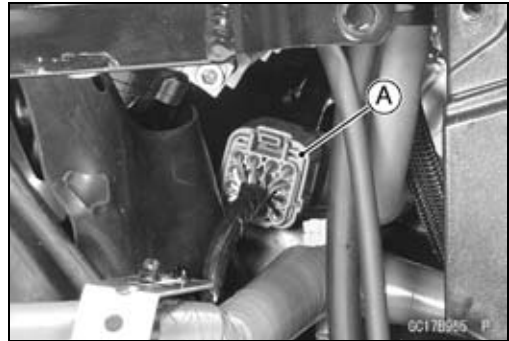

- Remove the connector [A] from the connector bracket.
- Insert the thin blade screw driver into the connector stopper portion from the right side of motorcycle.



- For the California Model, pull off the vacuum hoses [A].

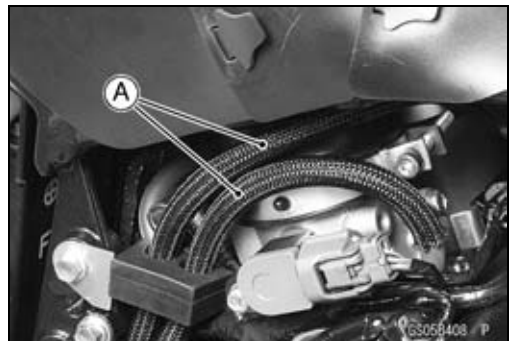

- Disconnect the crankshaft sensor lead connector [A].

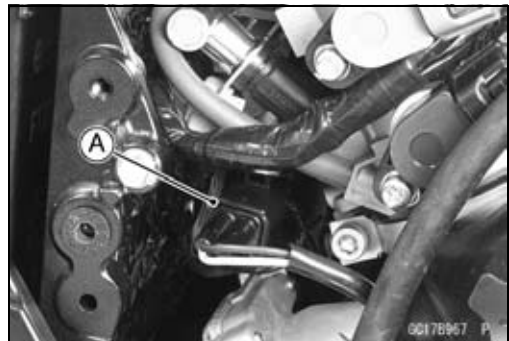

- Loosen the duct clamp bolts [A] on both sides.



Throttle Body Assy

- Remove:
 - Fuel Tank (see Fuel Tank Removal)
 - Inlet Air Temperature Sensor [A]
 - Bolts [B]
 - Left and Right Air Cleaner Caps [C]
- Do not disconnect the inlet air temperature sensor lead connector.

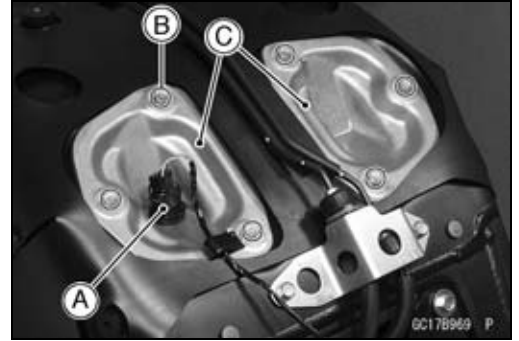

- Remove the duct clamps from the ducts [A], and pull out the ducts upward.

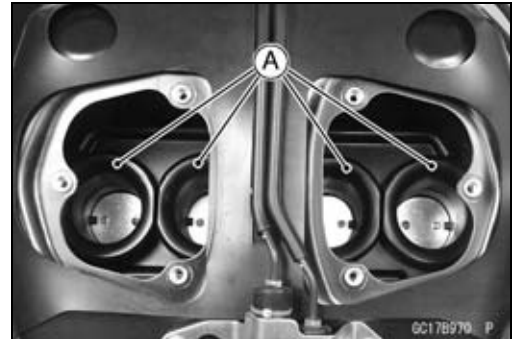

- Remove the grommets [A] as necessary.

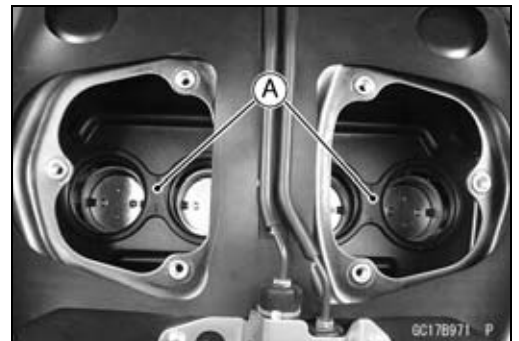

- Remove the throttle case [A] to make a throttle cable slack.

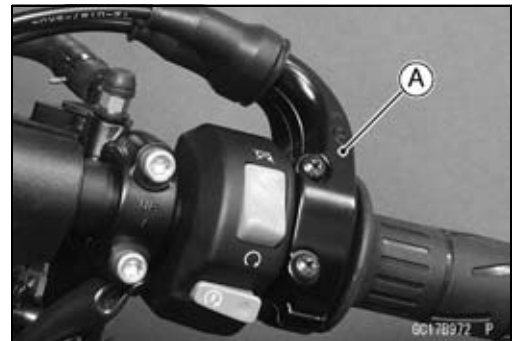

- Remove:
 - Clamp [A]
 - Throttle Cable Lower Ends [B]



3-116 FUEL SYSTEM (DFI)

Throttle Body Assy

- Remove the adjuster screw [A] from the clamp [B].

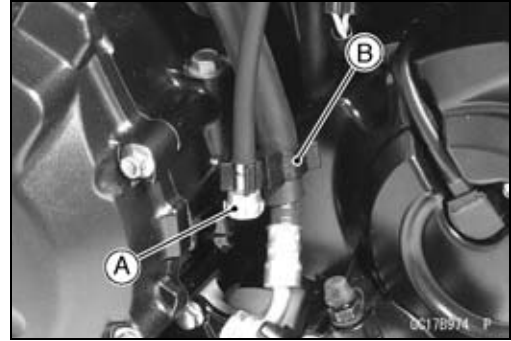

- Loosen the throttle body assy holder clamp bolts [A] on both sides.
- Pull out the throttle body assy [B] from the holder.
- Disconnect the fuel hose joint from the delivery pipe of the throttle body assy (see Fuel Hose Replacement in the Periodic Maintenance chapter).

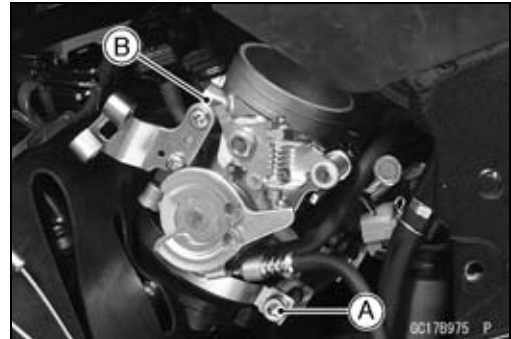

- Remove the throttle body assy [A] to the left side of motorcycle.
- After removing the throttle body assy, stuff pieces of lint-free, clean cloths into the throttle body assy holders.



CAUTION

If dirt gets into the engine, excessive engine wear and possible engine damage will occur.

Throttle Body Assy Installation

- Install the holder clamp bolts [A] in the direction as shown. Bolt Heads [B]
- Connect the fuel hose joint to the delivery pipe of the throttle body assy (see Fuel Hose Replacement in the Periodic Maintenance chapter).
- Tighten:

Torque - Throttle Body Assy Holder Clamp Bolts: 2.0 N·m (0.20 kgf·m, 18 in·lb)

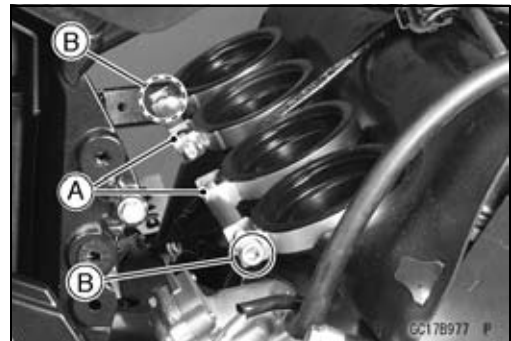

Throttle Body Assy

- ★ If the grommet [A] was removed, install it.
- Install the grommet from the inside of the frame.
- Insert the duct [B] to the grommet.
- Apply a soap and water solution or rubber lubricant to the oblique portion [C] on the duct for easy installation.
- Fit the projections [D] of the duct into the holes [E] in the clamp.

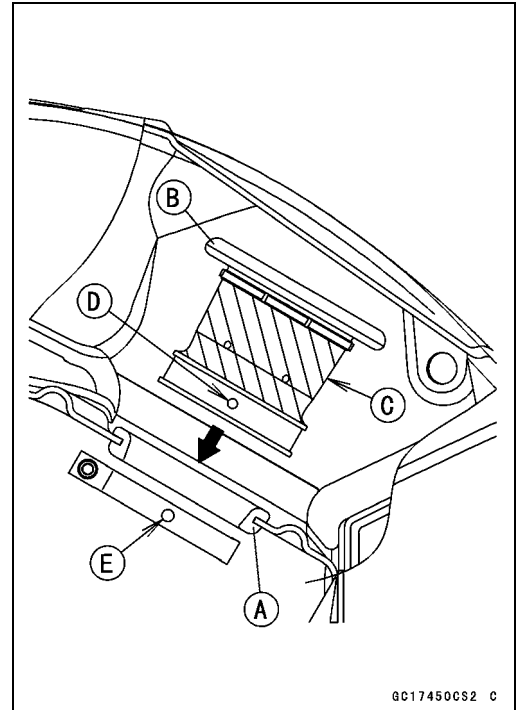

- Install the duct clamp bolts [A] in the direction as shown.
 - Front [B]
 - Upside View [C]
- Tighten:
 - Torque - Duct Clamp Bolts: 2.0 N·m (0.20 kgf·m, 18 in·lb)**

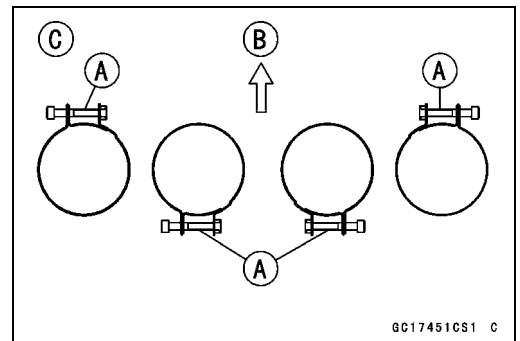

- Install the air cleaner caps.
- The right air cleaner cap [A] has a R mark [B].

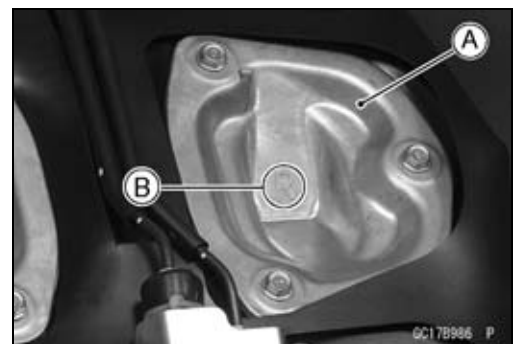

- Replace the subframe bolts with new ones, and tighten it.
 - Torque - Subframe Bolts: 23 N·m (2.3 kgf·m, 17 ft·lb)**
- Run the leads and hoses as shown in the Cable, Wire, and Hose Routing section of the Appendix chapter.
- Adjust:
 - Throttle Grip Free Play (see Throttle Control System Inspection in the Periodic Maintenance chapter)
 - Idle Speed (see Idle Speed Adjustment in the Periodic Maintenance chapter)

3-118 FUEL SYSTEM (DFI)

Throttle Body Assy

Throttle Body Assy Disassembly

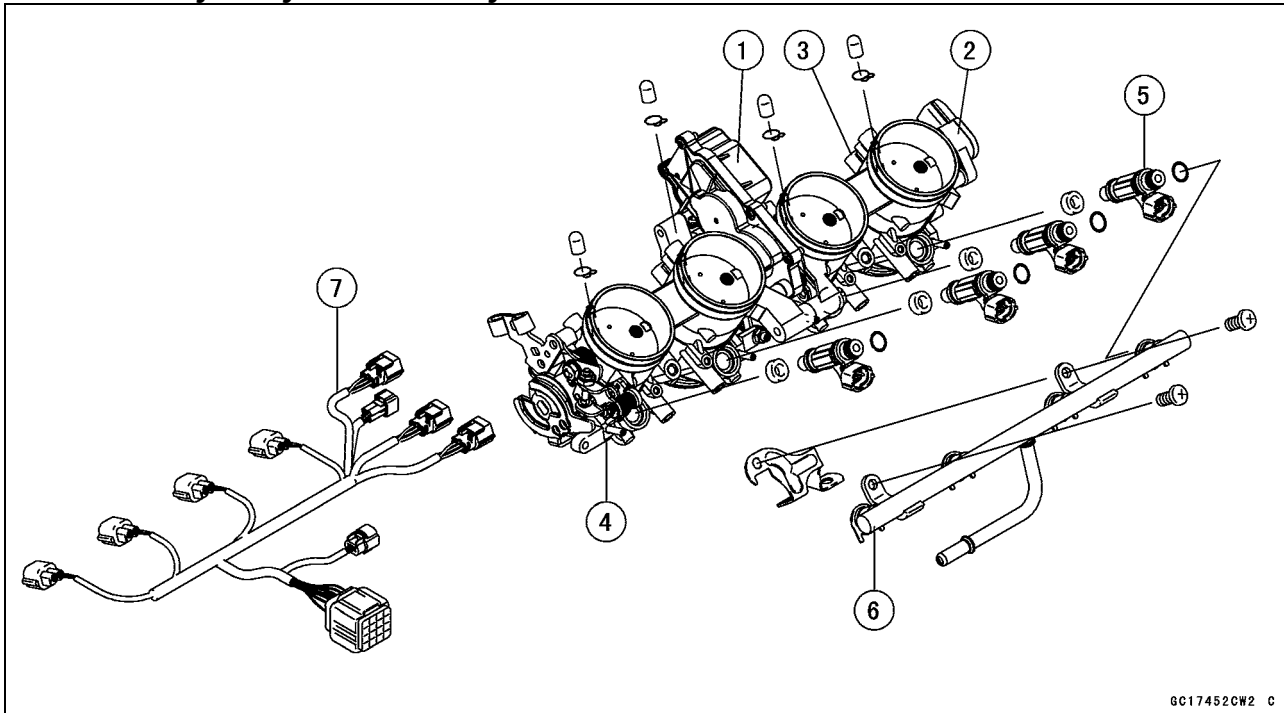

1. Subthrottle Valve Actuator
2. Subthrottle Sensor
3. Main Throttle Sensor
4. Throttle Body Assy
5. Injector
6. Delivery Pipe
7. Throttle Body Subharness

CAUTION

Do not remove, disassemble or adjust the main throttle sensor, subthrottle sensor, subthrottle valve actuator, throttle link mechanism and throttle body assy, because they are adjust or set surely at the manufacturer. Adjustment of these parts could result in poor performance, requiring replacement of the throttle body assy.

- Remove the throttle body assy (see Throttle Body Assy Removal).
- Disconnect the injector connectors [A].

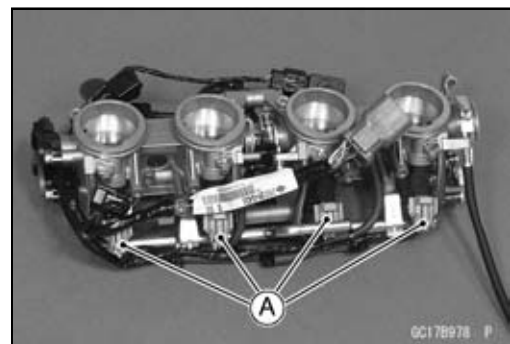

Throttle Body Assy

- Disconnect the main throttle sensor [A] and subthrottle sensor [B] connector.

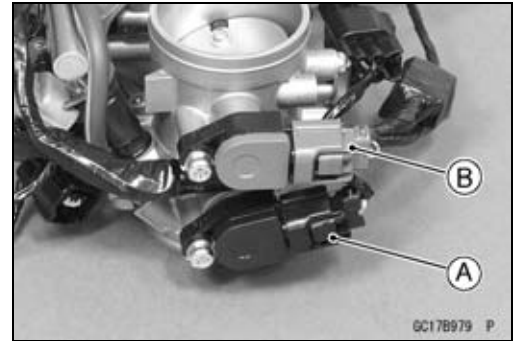

- Disconnect:
Subthrottle Valve Actuator Lead Connector [A]
Inlet Air Pressure Sensor Connector [B]

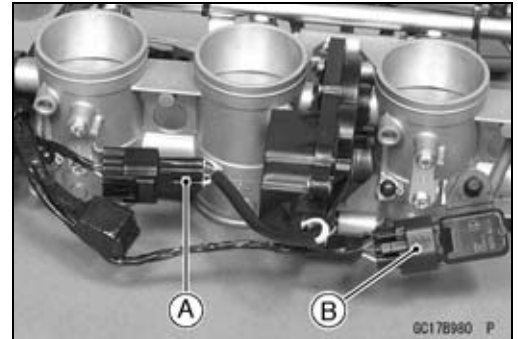

- Separate the hoses [A] from the throttle body fittings and inlet air pressure sensor.
- Remove the screws [B] to pull out the injector assies from the throttle body assy together with the delivery pipe [C].

NOTE

- Do not damage the insertion portions of the injectors when they are pulled out from the throttle body.

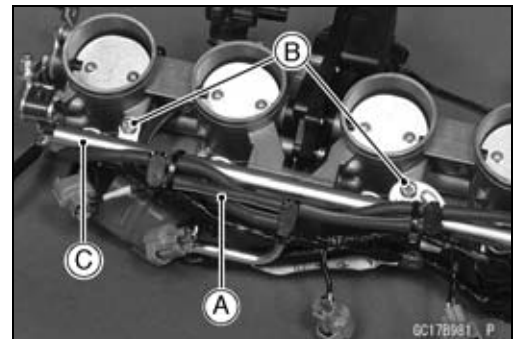

- Pull out the injectors [A] from the delivery pipe [B].

NOTE

- Do not damage the insertion portions of the injectors when they are pulled out from the delivery pipe.

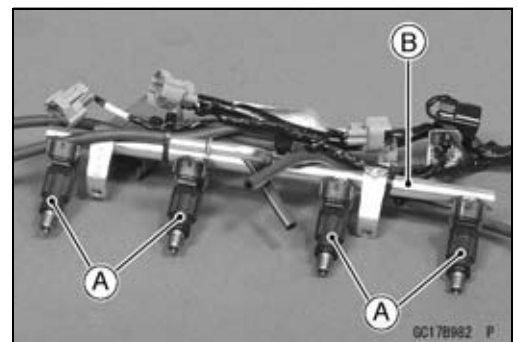

Throttle Body Assy Assembly

- Before assembling, blow away dirt or dust from the throttle body and delivery pipe by applying compressed air.
- Apply daphne oil or engine oil to the new O-rings [A] of each injector, insert them to the delivery pipe [B] and confirm whether the injectors turn smoothly or not.

NOTE

- Replace the O-rings of injectors to new ones.

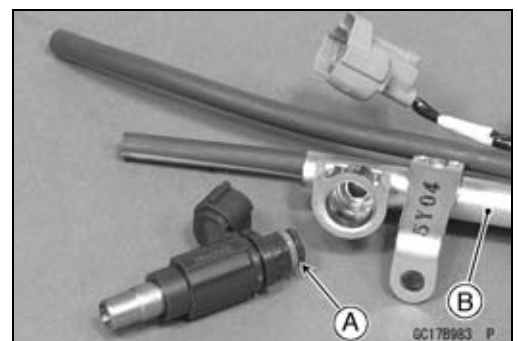

3-120 FUEL SYSTEM (DFI)

Throttle Body Assy

- Apply daphne oil or engine oil to the new dust seals [A], and insert the injectors into the throttle body, which installed to the delivery pipe.

NOTE

○Replace the dust seals of the throttle body to new ones.

- Install the delivery pipe to the throttle body.
Torque - Delivery Pipe Mounting Screws: 5.0 N·m (0.50 kgf·m, 44 in·lb)
- Connect the injector connectors.
- Insert the each hoses to the throttle body fittings and inlet air pressure sensor.
- Install the throttle body assy (see Throttle Body Assy Installation).

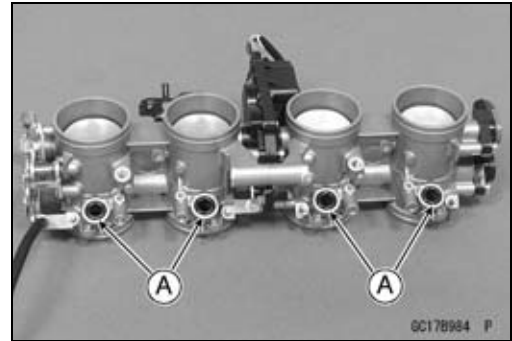

Air Line

Element Removal

- Refer to the Air Cleaner Element Replacement in the Periodic Maintenance chapter (see Air Cleaner Element Replacement in the Periodic Maintenance chapter).

Element Installation

- Refer to the Air Cleaner Element Replacement in the Periodic Maintenance chapter (see Air Cleaner Element Replacement in the Periodic Maintenance chapter).

Air Cleaner Element Inspection

- Remove the air cleaner element (see Air Cleaner Element Replacement in the Periodic Maintenance chapter).
- Visually check the element [A] for tears or breaks.
- ★ If the element has any tears or breaks, replace the element.

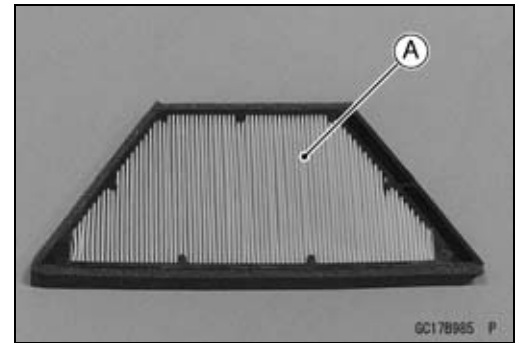

Air Cleaner Element Holder Removal

- Remove:
 - Air Cleaner Element (see Air Cleaner Element Replacement in the Periodic Maintenance chapter)
 - Screws [A]

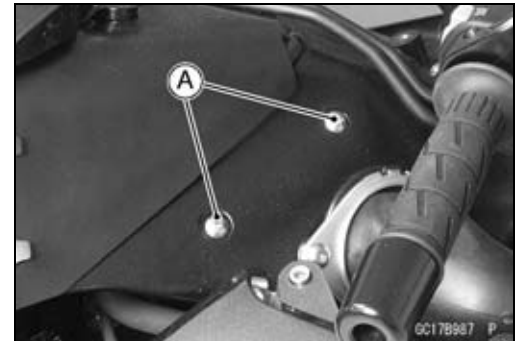

- Pull out the air cleaner element holder [A] from the housing.

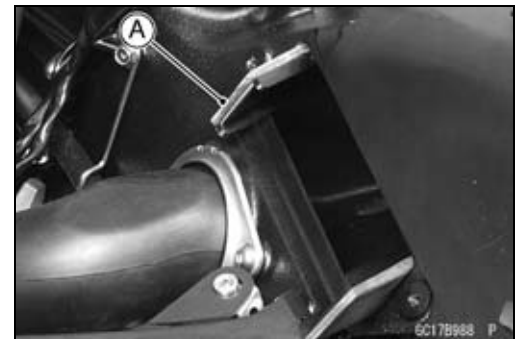

Air Cleaner Element Holder Installation

- Install the air cleaner element holder [A] so that the holder ends [B] insert along the rib [C] in the housing.
- Tighten:
 - Torque - Air Cleaner Element Holder Screws: 6.9 N·m (0.70 kgf·m, 61 in·lb)

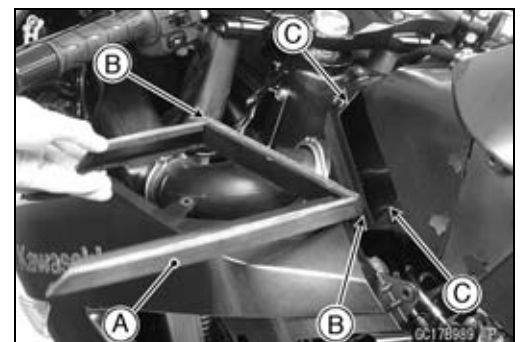

3-122 FUEL SYSTEM (DFI)

Air Line

Oil Draining

A drain hose is connected to the bottom of the air cleaner part to drain water or oil accumulated in the cleaner part.

- Visually check the catch tank of the drain hose [A], if the water or oil accumulates in the tank.
- ★ If any water or oil accumulates in the tank, remove the plug [B] from the tank and drain it.

⚠ WARNING

Be sure reinstall the plug in the tank after draining. Oil on tires will make them slippery and can cause an accident and injury.

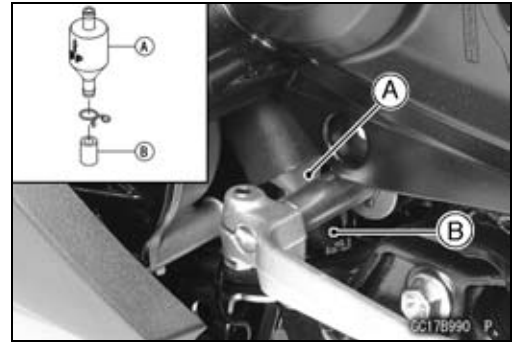

Rear Air Inlet Duct Removal

- Remove:
 - Left and Right Inner Covers (see Inner Cover Removal in the Frame chapter)
 - Fuel Tank Cover (see Fuel Tank Cover Removal)
- Loosen the clamp bolt [A] on both sides.
- Remove the mounting bolts [B] and, pull off the right rear air inlet ducts [C] to backward.
- Remove the left rear air inlet duct in the same way as right.

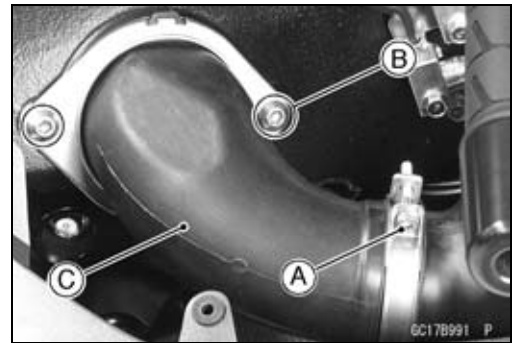

Rear Air Inlet Duct Installation

- Insert the projections [A] of the holder [B] in the holes [C] of rear air inlet duct [D].

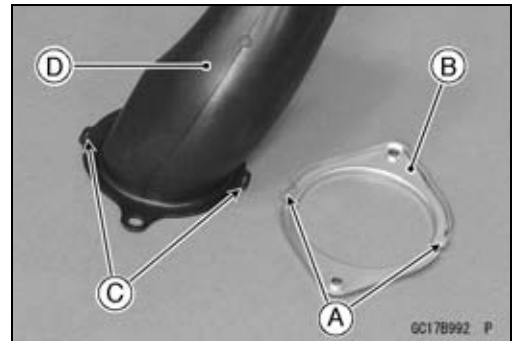

- Insert the rear air inlet duct [A] until the duct end [B] align the line [C] of middle air inlet duct [D].
- Tighten

Torque - Rear Air inlet Duct Mounting Bolts: 9.8 N·m (1.0 kgf·m, 87 in·lb)

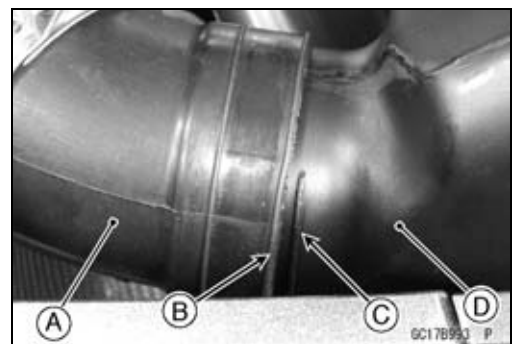

Air Line

- Install the clamp bolts [A] so that bolt heads [B] faces direction as shown.
 Left Clamp [C]
 Right Clamp [D]
 About 30° [E]
 Rear View [F]
- Tighten:
Torque - Middle Air inlet Duct Clamp Bolts: 2.9 N·m (0.30 kgf·m, 26 in·lb)

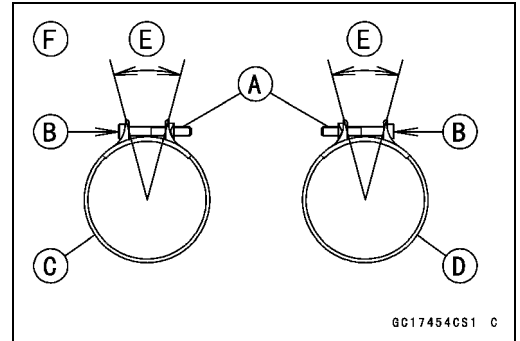

Front and Middle Air Inlet Duct Removal

- Remove the upper fairing (see Upper Fairing Removal in the Frame chapter).
- Open the clamps [A].



- Open the clamps [A].

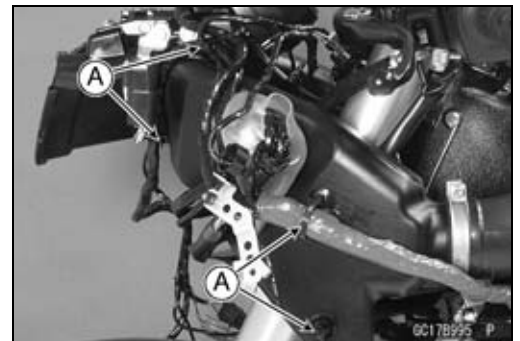

- Remove:
 Bolts [A]
 Front Air inlet Duct [B]
 Rubber Seal [C]
- Loosen the clamp bolts [D] on both sides.
- Remove the bolts [E] on both sides.
- Pull off the left and right middle air inlet ducts [F] to forward.

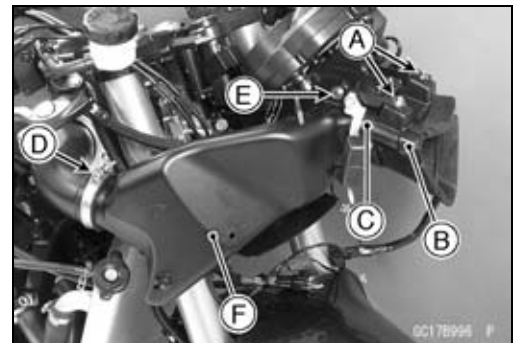

Front and Middle Air Inlet Duct Installation

NOTE

○The left middle air inlet duct has a L mark [A] and the right middle air inlet duct has a R mark.



3-124 FUEL SYSTEM (DFI)

Air Line

- Insert the middle air inlet duct [A] until the line [B] aligns with the duct end [C] of rear air inlet duct [D].
- Tighten:

Torque - Middle Air Inlet Duct Mounting Bolts: 9.8 N·m (1.0 kgf·m, 87 in·lb)

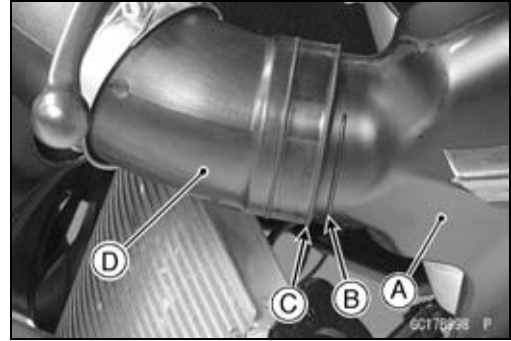

- Install the clamp bolt [A] so that bolt heads [B] face direction as shown.
Left Clamp [C]
Right Clamp [D]
About 30° [E]
Rear View [F]

- Tighten:

Torque - Middle Air Inlet Duct Clamp Bolts: 2.9 N·m (0.30 kgf·m, 26 in·lb)

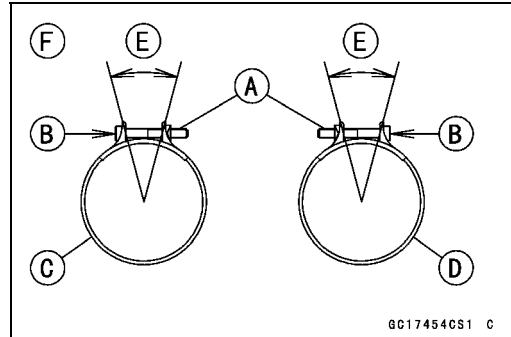

- Install the rubber seal [A] so that the hollow side [B] faces forward.
- Insert the front air inlet duct to the rubber seal, and tighten the bolts.

Torque - Front Air Inlet Duct Mounting Bolts: 9.8 N·m (1.0 kgf·m, 87 in·lb)

- Run the leads correctly (see Cable, Wire, and Hose Routing section in the Appendix chapter).

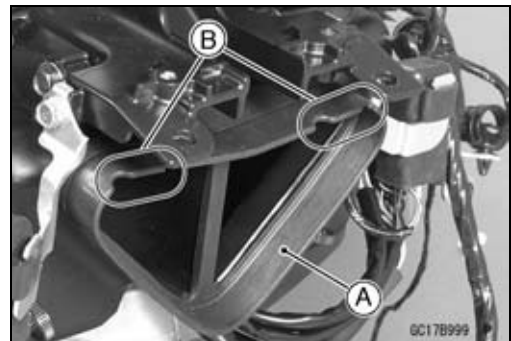

Fuel Tank

Fuel Tank Removal

⚠ WARNING
 Gasoline is extremely flammable and can be explosive under certain conditions. Make sure the area is well-ventilated and free from any source of flame or sparks; this includes any appliance with a pilot light. Do not smoke. Turn the ignition switch OFF. Be prepared for fuel spillage; any spilled fuel must be completely wiped up immediately.

- Turn the ignition switch OFF.
- Remove the left and right fairing covers (see Fairing Cover Removal in the Frame chapter).
- Disconnect the battery (–) terminal (see Battery Removal in the Electrical System chapter).
- Remove:
 - Left and Right Inner Covers (see Inner Cover Removal in the Frame chapter)
 - Bolt [A]
- Pull the fuel tank cover [A] evenly outward to clear the projections [B] on both sides.
- Remove the fuel tank cover to forward [C].



- Remove the bolts [A].



- Remove:
 - Bolts [A]
 - Drain Hose [B]
- For the California model, remove the following.
 - Fuel Return Hose [C] (right side, red)
 - Fuel Tank Breather Hose [D] (left side, blue)

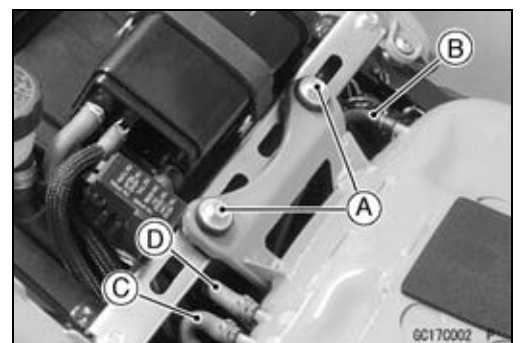

3-126 FUEL SYSTEM (DFI)

Fuel Tank

- Disconnect:
 - Fuel Pump Lead Connector [A]
 - Fuel Level Sensor Lead Connector [B]



- Open the fuel tank cap [A] to lower the pressure in the tank.
- During tank removal, keep the tank cap open to release pressure in the tank. This makes fuel spillage less.



- Draw the fuel out from the fuel tank with a commercially available pump [A].
 - Use a soft plastic hose [B] as a pump inlet hose in order to insert the hose smoothly.
 - Put the hose through the fill opening [C] into the tank and draw the fuel out.
- Front [D]

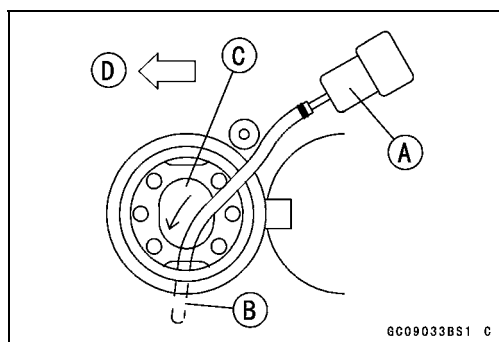

⚠ WARNING

The fuel could not be removed completely from the fuel tank. Be careful for remained fuel spillage.

- Be sure to place a piece of cloth [A] around the fuel hose joint [B].
- Push the joint lock claws [C].

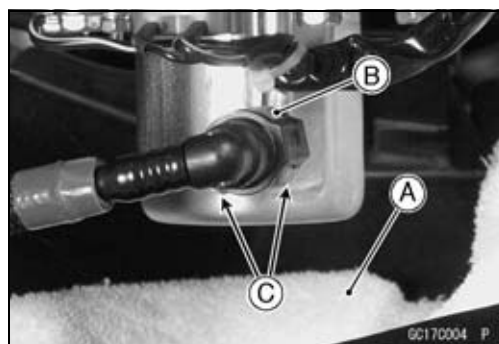

- Pull the joint lock [A] as shown.
- Pull [B] the fuel hose joint [C] out of the delivery pipe.

⚠ WARNING

Be prepared for fuel spillage; any spilled fuel must be completely wiped up immediately. When the fuel hose is disconnected, fuel spills out from the hose and the pipe because of residual pressure. Cover the hose connection with a piece of clean cloth to prevent fuel spillage.

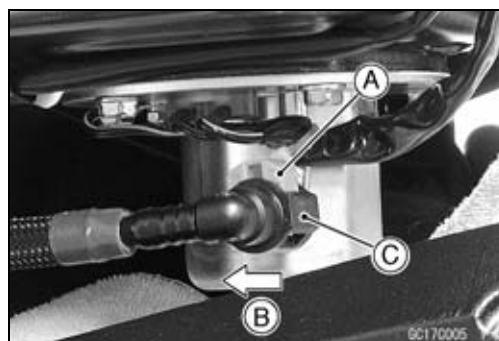

- Close the fuel tank cap.
- Remove the fuel tank, and place it on a flat surface.
- Do not apply the load to the delivery pipe of the fuel pump.

Fuel Tank

- For the California Model, note the following.

CAUTION

For the California model, if gasoline, solvent, water or any other liquid enters the canister, the canister's vapor absorbing capacity is greatly reduced. If the canister does become contaminated, replace it with a new one.

- Be sure to plug the evaporative fuel return hose to prevent fuel spilling before fuel tank removal.

▲ WARNING

For the California model, be careful not to spill the gasoline through the return hose. Spilled fuel is hazardous.

- ★ If liquid or gasoline flows into the breather hose, remove the hose and blow it clean with compressed air (California model).
- Be careful of fuel spillage from the fuel tank since fuel still remains in the fuel tank and fuel pump.

▲ WARNING

Store the fuel tank in an area which is well-ventilated and free from any source of flame or sparks. Do not smoke in this area. Place the fuel tank on a flat surface and plug the fuel pipes to prevent fuel leakage.

Fuel Tank Installation

- Note the above WARNING (see Fuel Tank Removal).
- Route the hoses correctly (see Cable, Wire, and Hose Routing section in the Appendix chapter).
- Check that the dampers [A] and pad [B] are in place on the fuel tank as well.
- ★ If the dampers are damaged or deteriorated, replace them.
- For the California Model, note the following.
 - To prevent the gasoline from flowing into or out of the canister, hold the separator perpendicular to the ground.
 - Connect the hoses according to the diagram of the system (see Cable, Wire, and Hose Routing section in the Appendix chapter). Make sure they do not get pinched or kinked.
 - Route hoses with a minimum of bending so that the air or vapor will not be obstructed.

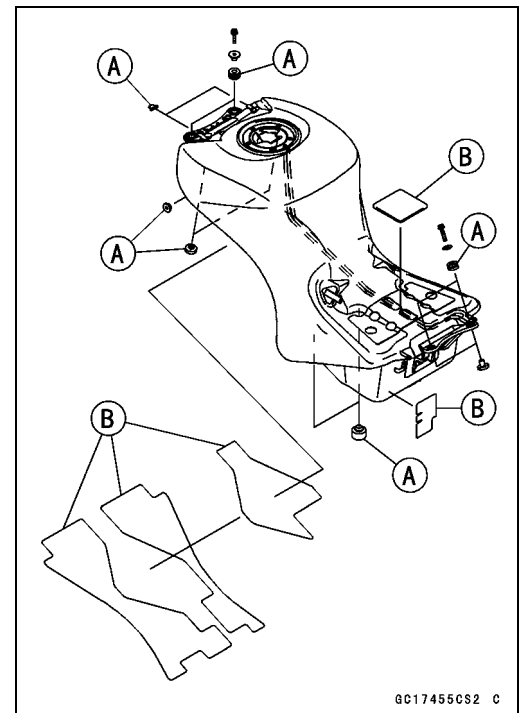

3-128 FUEL SYSTEM (DFI)

Fuel Tank

- Pull the joint lock [A] as shown.



- Insert the fuel hose joint [A] straight onto the delivery pipe until the hose joint clicks.
- Push the joint lock [B] until the hose joint clicks.

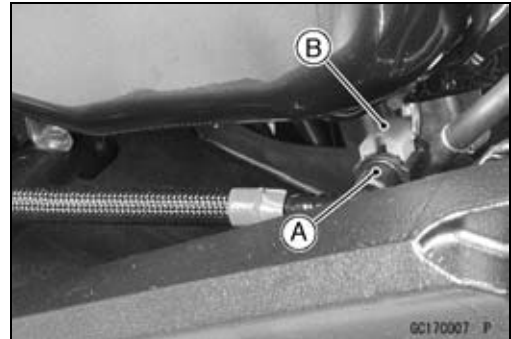

- Push and pull [A] the hose joint [B] back and forth more than two times and make sure it is locked and doesn't come off. When the hose joint is correctly installed, it should slide on the delivery pipe about 5 mm (0.2 in.).

⚠ WARNING

Make sure the hose joint is installed correctly on the delivery pipe by sliding the joint, or the fuel could leak.

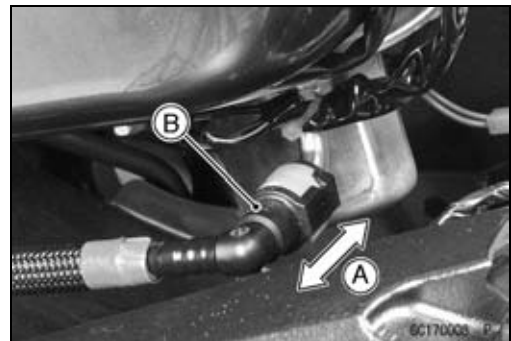

- ★ If it does not slide, reinstall the hose joint.
- Connect the fuel pump, fuel level sensor lead connectors and the battery (-) terminal (see Battery Installation in the Electrical System chapter).
- For models equipped with an ABS, fit the grooves of the damper [A] on the brake pipes [B].

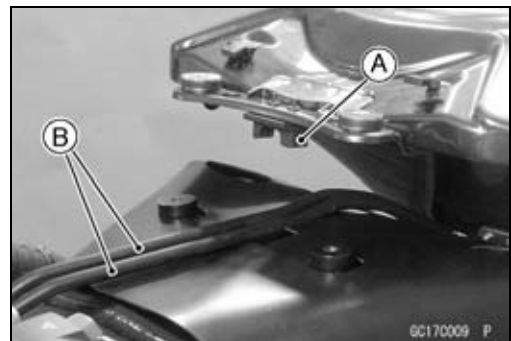

Fuel Tank

- Fit the dampers [A] of the fuel tank into the slots [B] of the fuel tank cover [C].

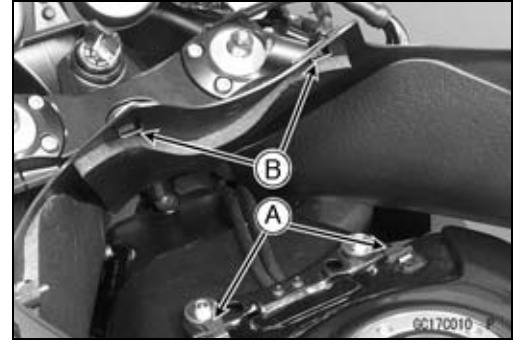

Fuel Tank and Cap Inspection

- Visually inspect the gasket [A] on the tank cap for any damage.
- ★ Replace the gasket if it is damaged.
- Check to see if the water drain pipe [B] and fuel breather pipe [C] (California Model) in the tank are not clogged. Check the tank cap breather also.
- ★ If they are clogged, remove the tank and drain it, and then blow the breather free with compressed air.

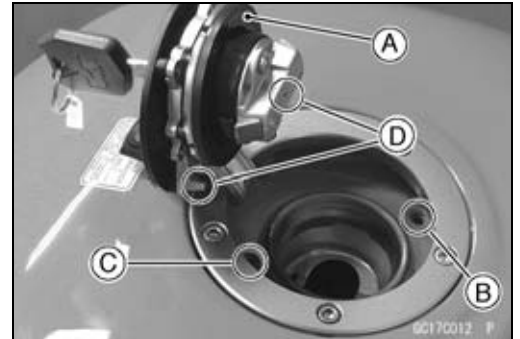

CAUTION

Do not apply compressed air to the air vent holes [D] in the tank cap. This could cause damage and clogging of the labyrinth in the cap.

Fuel Tank Cleaning

⚠ WARNING

Clean the tank in a well-ventilated area, and take care that there are no sparks or flame anywhere near the working area. Because of the danger or highly flammable liquids, do not use gasoline or low-flash point solvents to clean the tank.

- Remove:
 - Fuel Tank (see Fuel Tank Removal)
 - Fuel Pump (see Fuel Pump Removal)
- Pour some high-flash point solvent into the fuel tank and shake the tank to remove dirt and fuel deposits.
- Draw the solvent out of the fuel tank.
- Dry the tank with compressed air.
- Install:
 - Fuel Pump (see Fuel Pump Installation)
 - Fuel Tank (see Fuel Tank Installation)

3-130 FUEL SYSTEM (DFI)

Evaporative Emission Control System

The Evaporative Emission Control System routes fuel vapors from the fuel system into the running engine or stores the vapors in a canister when the engine is stopped. Although no adjustments are required, a thorough visual inspection must be made at the intervals specified by the Periodic Maintenance Chart.

Parts Removal/Installation

⚠ WARNING

Gasoline is extremely flammable and can be explosive under certain conditions. Turn the ignition switch OFF. Do not smoke. Make sure the area is well-ventilated and free from any source of flame or sparks; this includes any appliance with a pilot light.

CAUTION

If gasoline, solvent, water or any other liquid enters the canister, the canister's vapor absorbing capacity is greatly reduced. If the canister does become contaminated, replace it with a new one.

- To prevent the gasoline from flowing into or out of the canister, hold the separator perpendicular to the ground.
- Connect the hoses according to the diagram of the system. Make sure they do not get pinched or kinked.

Hose Inspection

- Refer to the Evaporative Emission Control System Inspection in the Periodic Maintenance chapter (see Evaporative Emission Control System Inspection in the Periodic Maintenance chapter).

Separator Inspection

- Refer to the Evaporative Emission Control System Inspection in the Periodic Maintenance chapter (see Evaporative Emission Control System Inspection in the Periodic Maintenance chapter).

Separator [A]



Evaporative Emission Control System

Separator Operation Test

⚠ WARNING

Gasoline is extremely flammable and can be explosive under certain conditions. Turn the ignition switch OFF. Do not smoke. Make sure the area is well-ventilated and free from any source of flame or sparks; this includes any appliance with a pilot light.

- Connect the hoses to the separator, and install the separator on the motorcycle.
- Disconnect the breather hose from the separator, and inject about 20 mL (0.68 US oz.) of gasoline [A] into the separator [B] through the hose fitting.
- Disconnect the fuel return hose [C] from the fuel tank [D].
- Run the open end of the return hose into the container and hold it level with the tank top [E].
- Start the engine, and let it idle.
- ★ If the gasoline in the separator comes out of the hose, the separator works well. If it does not, replace the separator with a new one.

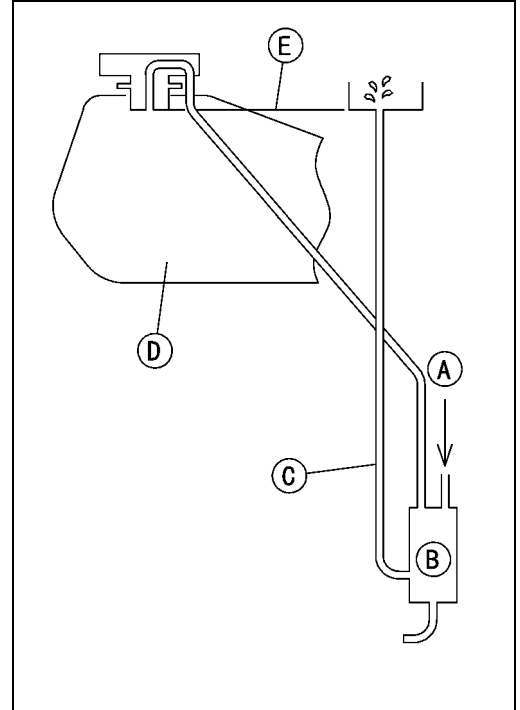

Canister Inspection

- Refer to the Evaporative Emission Control System Inspection in the Periodic Maintenance chapter (see Evaporative Emission Control System Inspection in the Periodic Maintenance chapter).

NOTE

○ The canister [A] is designed to work well through the motorcycle's life without any maintenance if it is used under normal conditions.

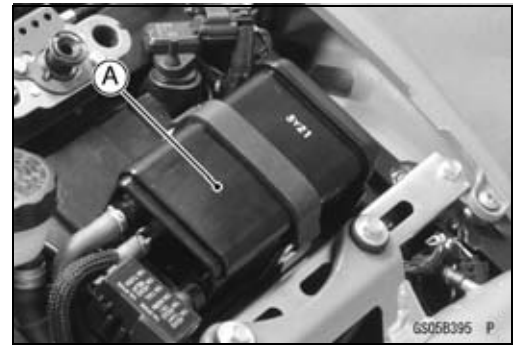

3-132 FUEL SYSTEM (DFI)

Evaporative Emission Control System

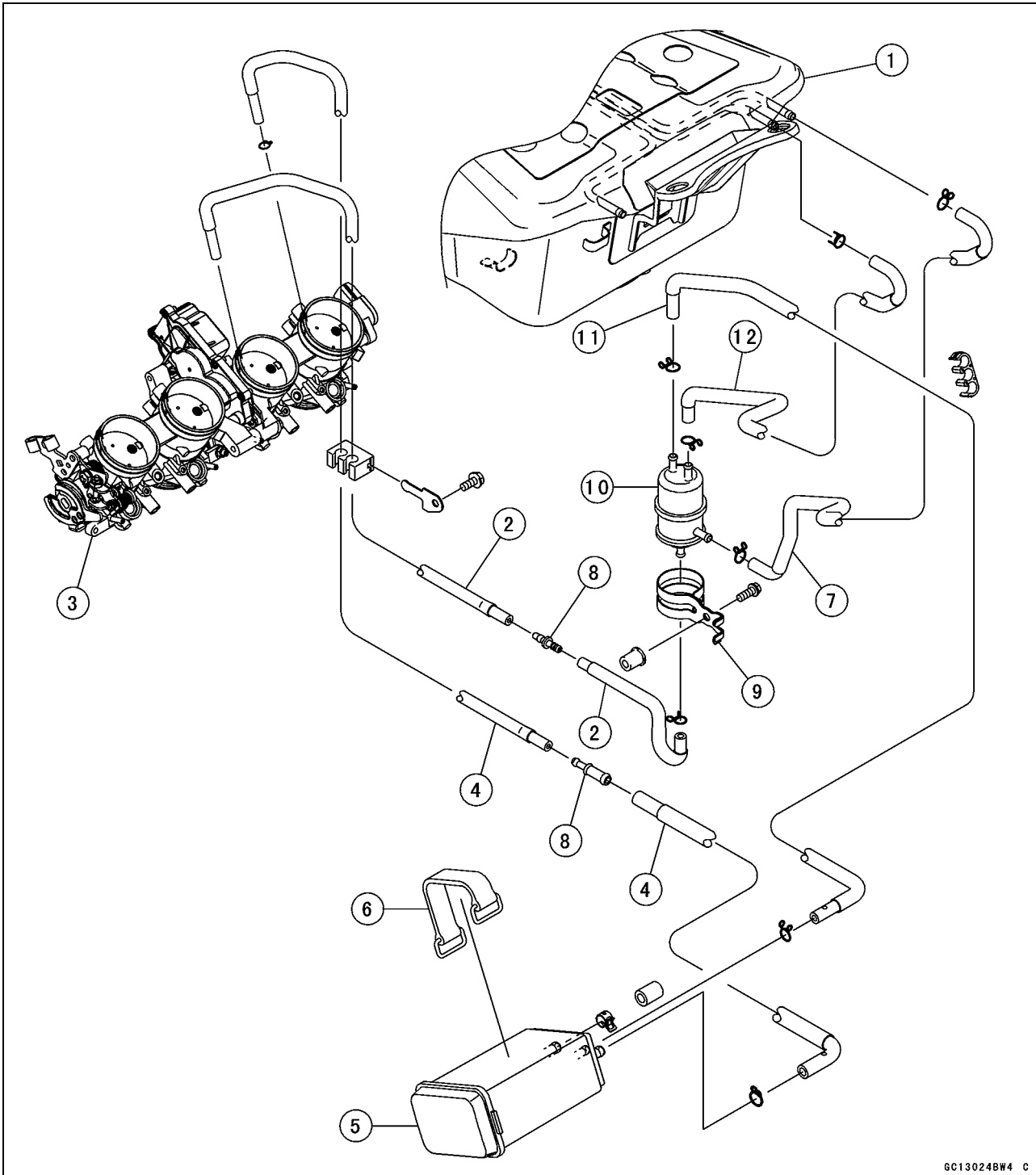

GC13024BW4 C

1. Fuel Tank
2. White Hose (Vacuum)
3. Throttle Body Assy
4. Green Hose (Purge)
5. Canister
6. Band (for Canister)
7. Red Hose (Right, Return)
8. Fitting
9. Bracket (for Separator)
10. Separator
11. Blue Hose (Breather)
12. Blue Hose (Left, Breather)

Cooling System

Table of Contents

Exploded View	4-2
Coolant Flow Chart	4-4
Specifications	4-6
Coolant	4-7
Coolant Deterioration Inspection	4-7
Coolant Level Inspection	4-7
Coolant Draining	4-7
Coolant Filling	4-7
Pressure Testing	4-7
Cooling System Flushing	4-8
Coolant Reserve Tank Removal/Installation	4-8
Water Pump	4-9
Water Pump Removal	4-9
Water Pump Installation	4-9
Water Pump Impeller Inspection	4-10
Radiator	4-11
Radiator and Radiator Fan Removal	4-11
Radiator and Radiator Fan Installation	4-12
Radiator Inspection	4-12
Radiator Cap Inspection	4-13
Radiator Filler Neck Inspection	4-13
Thermostat	4-14
Thermostat Removal	4-14
Thermostat Installation	4-14
Thermostat Inspection	4-14
Hoses and Pipes	4-16
Hose Installation	4-16
Hose Inspection	4-16
Water Temperature Sensor	4-17
Water Temperature Sensor Removal	4-17
Water Temperature Sensor Inspection	4-17

4-2 COOLING SYSTEM

Exploded View

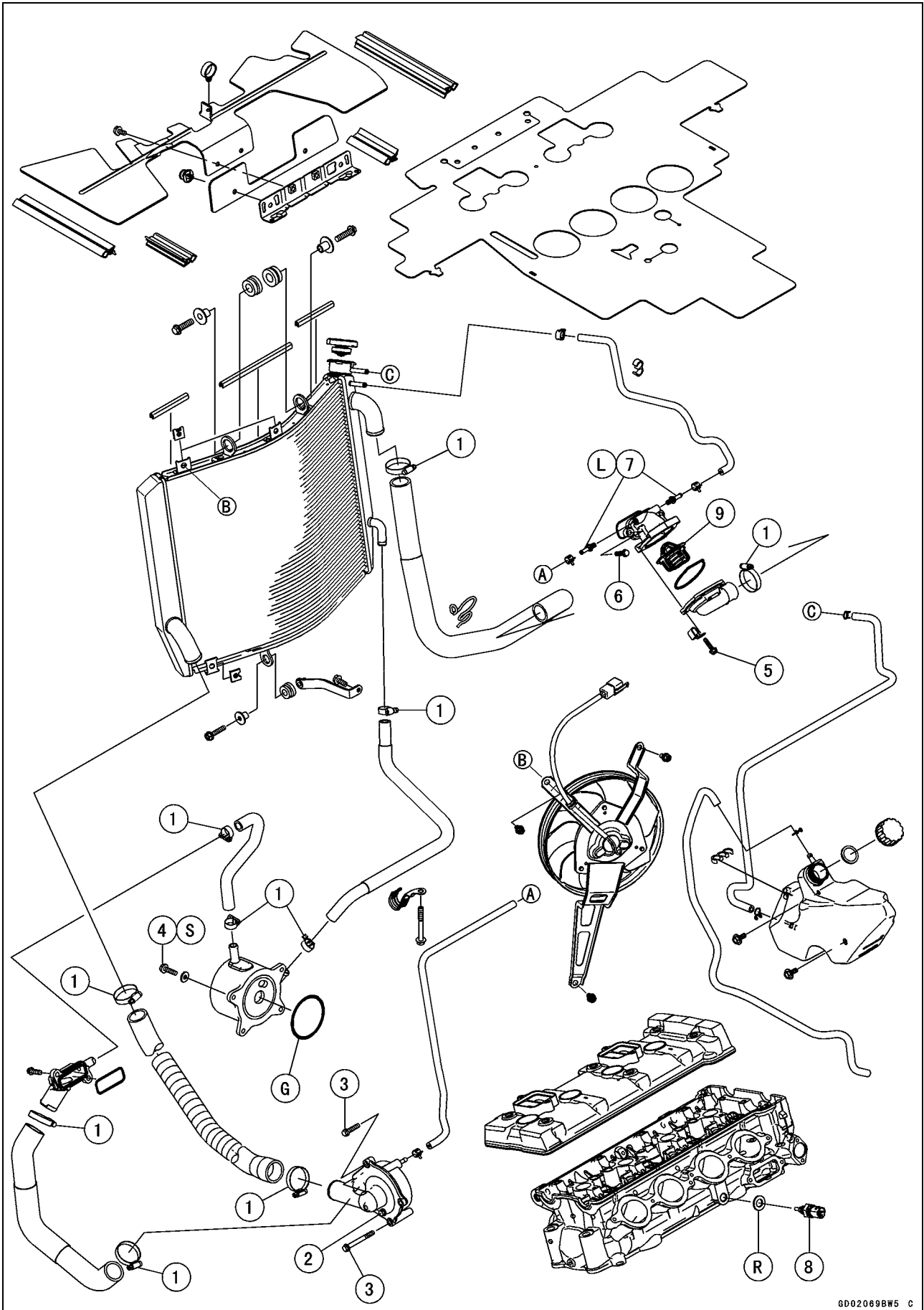

Exploded View

No.	Fastener	Torque			Remarks
		N·m	kgf·m	ft·lb	
1	Radiator Hose Clamp Screws	2.0	0.20	18 in·lb	
2	Coolant Drain Plug	12	1.2	106 in·lb	
3	Water Pump Cover Bolts	9.8	1.0	87 in·lb	
4	Oil Cooler Mounting Bolts	12	1.2	106 in·lb	S
5	Thermostat Housing Cover Bolts	5.9	0.60	52 in·lb	
6	Thermostat Housing Mounting Bolts	9.8	1.0	87 in·lb	
7	Coolant Fitting Bolt	8.8	0.90	78 in·lb	L
8	Water Temperature Sensor	25	2.5	18	

9. Thermostat

G: Apply grease.

L: Apply a non-permanent locking agent.

R: Replacement Parts

S: Follow the specified tightening sequence.

4-4 COOLING SYSTEM

Coolant Flow Chart

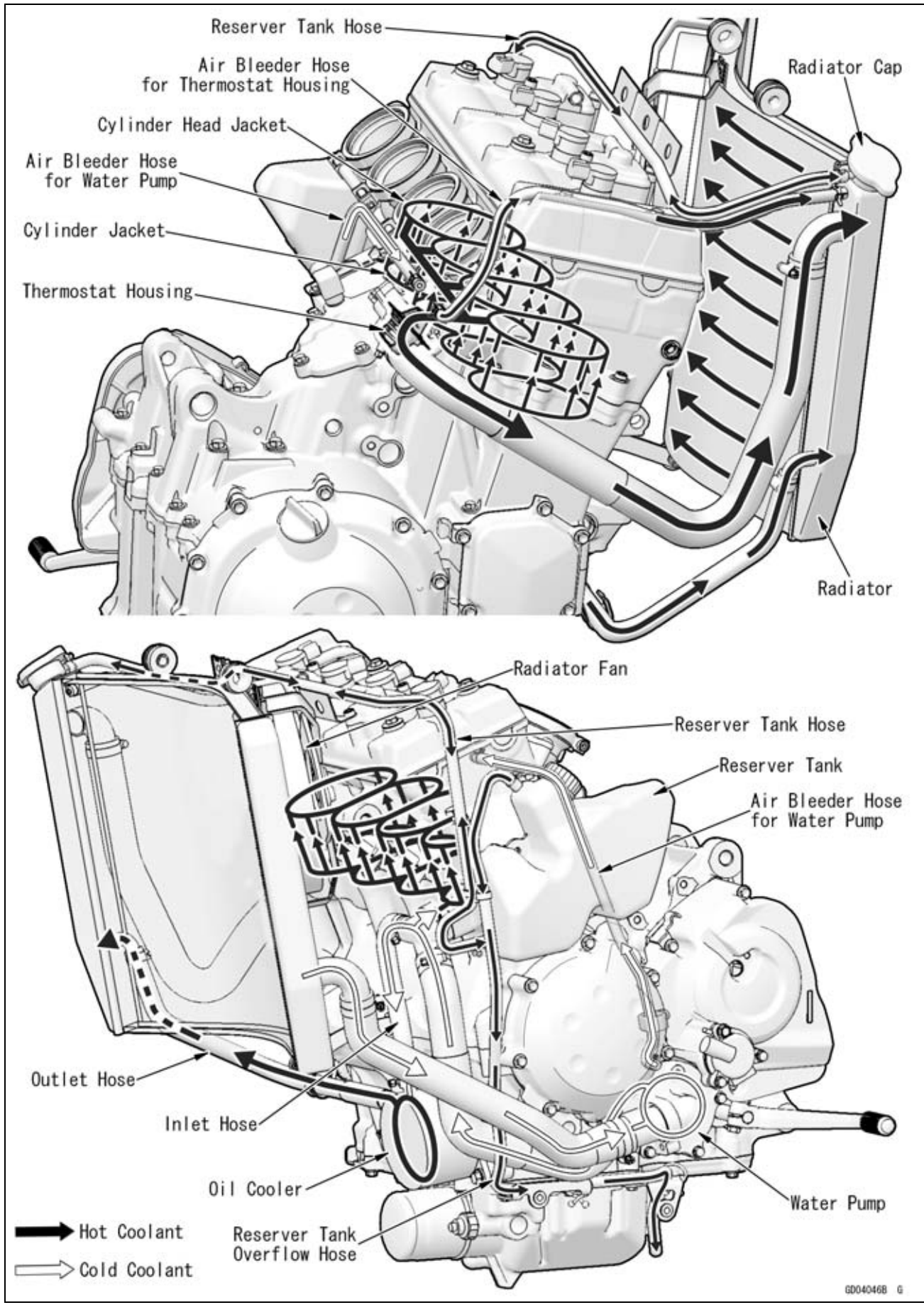

Coolant Flow Chart

Permanent type antifreeze is used as a coolant to protect the cooling system from rust and corrosion. When the engine starts, the water pump turns and the coolant circulates.

The thermostat is a wax pellet type which opens or closes with coolant temperature changes. The thermostat continuously changes its valve opening to keep the coolant temperature at the proper level. When coolant temperature is less than 55°C (131°F), the thermostat closes so that the coolant flow is restricted through the air bleeder hole, causing the engine to warm up more quickly. When coolant temperature is more than 58 ~ 62°C (136 ~ 144°F), the thermostat opens and the coolant flows.

When the coolant temperature goes up beyond 95°C (203°F), the radiator fan relay conducts to operate the radiator fan. The radiator fan draws air through the radiator core when there is not sufficient air flow such as at low speeds. This increases up the cooling action of the radiator. When the coolant temperature is below 90°C (194°F), the fan relay opens and the radiator fan stops.

In this way, this system controls the engine temperature within narrow limits where the engine operates most efficiently even if the engine load varies.

The system is pressurized by the radiator cap to suppress boiling and the resultant air bubbles which can cause engine overheating. As the engine warms up, the coolant in the radiator and the water jacket expands. The excess coolant flows through the radiator cap and hose to the reserve tank to be stored there temporarily. Conversely, as the engine cools down, the coolant in the radiator and the water jacket contracts, and the stored coolant flows back to the radiator from the reserve tank.

The radiator cap has two valves. One is a pressure valve which holds the pressure in the system when the engine is running. When the pressure exceeds 93 ~ 123 kPa (0.95 ~ 1.25 kgf/cm², 13 ~ 18 psi), the pressure valve opens and releases the pressure to the reserve tank. As soon as pressure escapes, the valve closes, and keeps the pressure at 93 ~ 123 kPa (0.95 ~ 1.25 kgf/cm², 13 ~ 18 psi). When the engine cools down, another small valve (vacuum valve) in the cap opens. As the coolant cools, the coolant contracts to form a vacuum in the system. The vacuum valve opens and allows the coolant from the reserve tank to enter the radiator.

4-6 COOLING SYSTEM

Specifications

Item	Standard
Coolant Provided when Shipping Type (Recommended) Color Mixed Ratio Freezing Point Total Amount	Permanent type of antifreeze (soft water and ethylene glycol plus corrosion and rust inhibitor chemicals for aluminum engines and radiators) Green Soft water 50%, coolant 50% -35°C (-31°F) 3.4 L (3.6 US qt) (Reserve tank full level, including radiator and engine)
Radiator Cap Relief Pressure	93 ~ 123 kPa (0.95 ~ 1.25 kgf/cm ² , 13 ~ 18 psi)
Thermostat Valve Opening Temperature Valve Full Opening Lift	58 ~ 62°C (136 ~ 144°F) 8 mm (0.31 in.) or more @75°C (167°F)

Coolant

Coolant Deterioration Inspection

- Visually inspect the coolant in the reserve tank.
- ★ If whitish cotton-like wafts are observed, aluminum parts in the cooling system are corroded. If the coolant is brown, iron or steel parts are rusting. In either case, flush the cooling system.
- ★ If the coolant gives off an abnormal smell, check for a cooling system leak. It may be caused by exhaust gas leaking into the cooling system.

Coolant Level Inspection

- Refer to the Coolant Level Inspection in the Periodic Maintenance chapter.

Coolant Draining

- Refer to the Coolant Change in the Periodic Maintenance chapter.

Coolant Filling

- Refer to the Coolant Change in the Periodic Maintenance chapter.

Pressure Testing

- Remove the right middle fairing (see Middle Fairing Removal in the Frame chapter).
- Remove the radiator cap, and install the cooling system pressure tester [A] on the filler neck.

NOTE

○ *Wet the cap sealing surfaces with water or coolant to prevent pressure leaks.*

- Build up pressure in the system carefully until the pressure reaches 142 kPa (1.45 kgf/cm², 21 psi).

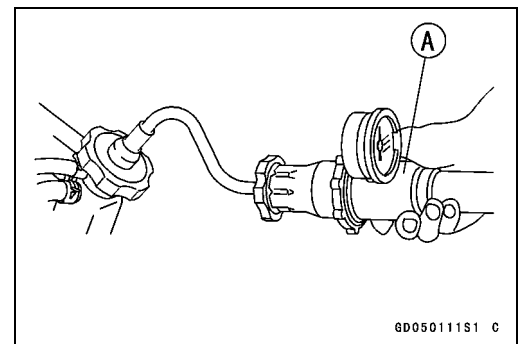

CAUTION

During pressure testing, do not exceed the pressure for which the system is designed. The maximum pressure is 142 kPa (1.45 kgf/cm², 21 psi).

- Watch the gauge for at least 6 seconds.
- ★ If the pressure holds steady, the system is all right.
- ★ If the pressure drops and no external source is found, check for internal leaks. Droplets in the engine oil indicate internal leakage. Check the cylinder head gasket and the water pump.
- Remove the pressure tester, replenish the coolant, and install the radiator cap.

4-8 COOLING SYSTEM

Coolant

Cooling System Flushing

Over a period of time, the cooling system accumulates rust, scale, and lime in the water jacket and radiator. When this accumulation is suspected or observed, flush the cooling system. If this accumulation is not removed, it will clog up the water passage and considerably reduce the efficiency of the cooling system.

- Drain the cooling system (see Coolant Change in the Periodic Maintenance chapter).
- Fill the cooling system with fresh water mixed with a flushing compound.

CAUTION
Do not use a flushing compound which is harmful to the aluminum engine and radiator. Carefully follow the instructions supplied by the manufacturer of the cleaning product.

- Warm up the engine, and run it at normal operating temperature for about ten minutes.
- Stop the engine, and drain the cooling system.
- Fill the system with fresh water.
- Warm up the engine and drain the system.
- Repeat the previous two steps once more.
- Fill the system with a permanent type coolant and bleed the air from the system (see Coolant Change in the Periodic Maintenance chapter).

Coolant Reserve Tank Removal/Installation

- The coolant reserve tank is removed and installed during coolant change (see Coolant Change in the Periodic Maintenance chapter).

Water Pump

Water Pump Removal

- Drain:
 - Coolant (see Coolant Change in the Periodic Maintenance chapter)
 - Engine Oil (see Engine Oil Change in the Periodic Maintenance chapter)
- Remove:
 - Clutch Slave Cylinder (see Clutch Slave Cylinder Removal in the Clutch chapter)
 - Engine Sprocket Cover (see Engine Sprocket Removal in the Final Drive chapter)
- Remove:
 - Radiator Hose [A]
 - Water Pump Cover Bolts [B]
 - Water Pump Cover [C]

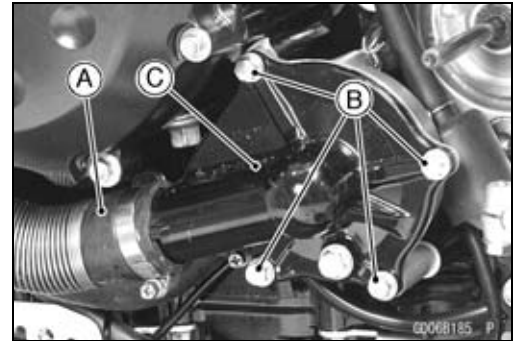

- Remove the radiator hose [A] and the air bleeder hose [B] for the water pump body.
- Remove the water pump body [C] with impeller [D].



Water Pump Installation

- Turn the pump drive gear shaft so that the slot [A] in its shaft fits onto the projection [B] of the impeller shaft.

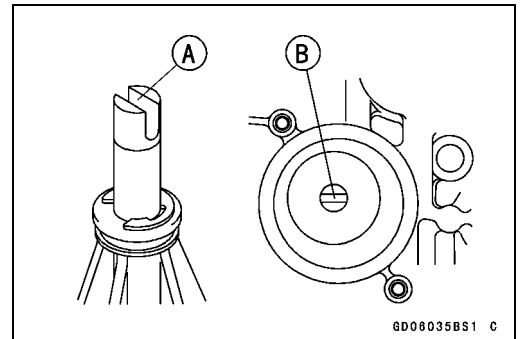

- Install the radiator hose [A] and the air bleeder hose [B] for the water pump body as shown.



4-10 COOLING SYSTEM

Water Pump

- Install the water pump cover [A].
- Tighten:
Torque - Water Pump Cover Bolts: 9.8 N·m (1.0 kgf·m, 87 in·lb)
- Install the water hose [B] as shown.

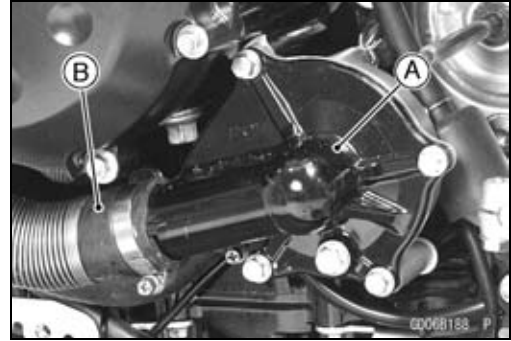

Water Pump Impeller Inspection

- Visually inspect the water pump impeller [A].
- ★ If the surface is corroded or if the blades are damaged, replace the water pump assy.

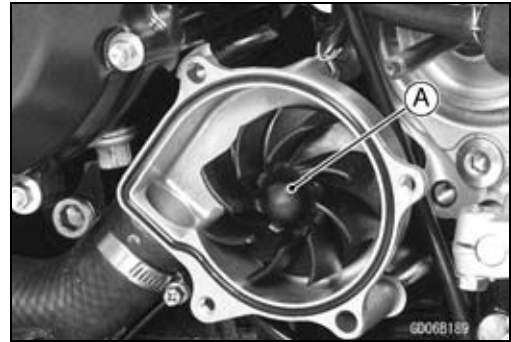

Radiator

Radiator and Radiator Fan Removal

- Remove:
 - Middle Fairings (see Middle Fairing Removal in the Frame chapter)
 - Coolant (Drain, see Coolant Change in the Periodic Maintenance chapter)
 - Reservoir Tank Hose [A]
 - Air Bleeder Hose [B] for Thermostat Housing
 - Radiator Hose [C]
 - Oil Cooler Outlet Hose [D]
 - Radiator Upper Bolt [E]

- Remove:
 - Radiator Fan Lead Connector [A]
 - Radiator Hose [B]
 - Radiator Lower Bolt [C]
 - Radiator Upper Bolt [D]
- Remove the radiator [E].

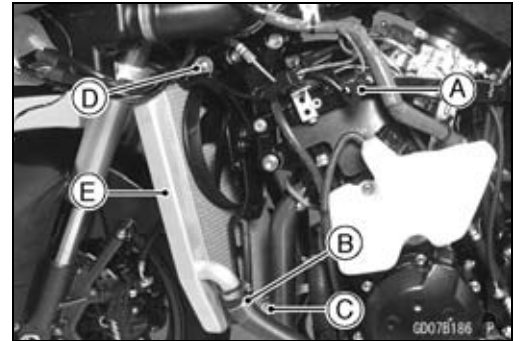
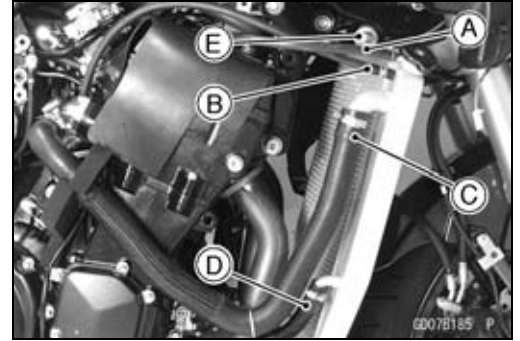

CAUTION

Do not touch the radiator core. This could damage the radiator fins, resulting in loss of cooling efficiency.

- Remove:
 - Radiator Fan Mounting Bolts [A]
 - Radiator Fan [B]

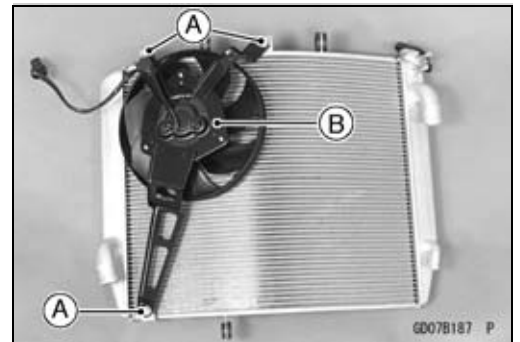

4-12 COOLING SYSTEM

Radiator

Radiator and Radiator Fan Installation

- Be sure that the trim seals [A] are in position on the radiator as shown.
- Install the dampers [B], radiator bracket collars [C] and bolts as shown.

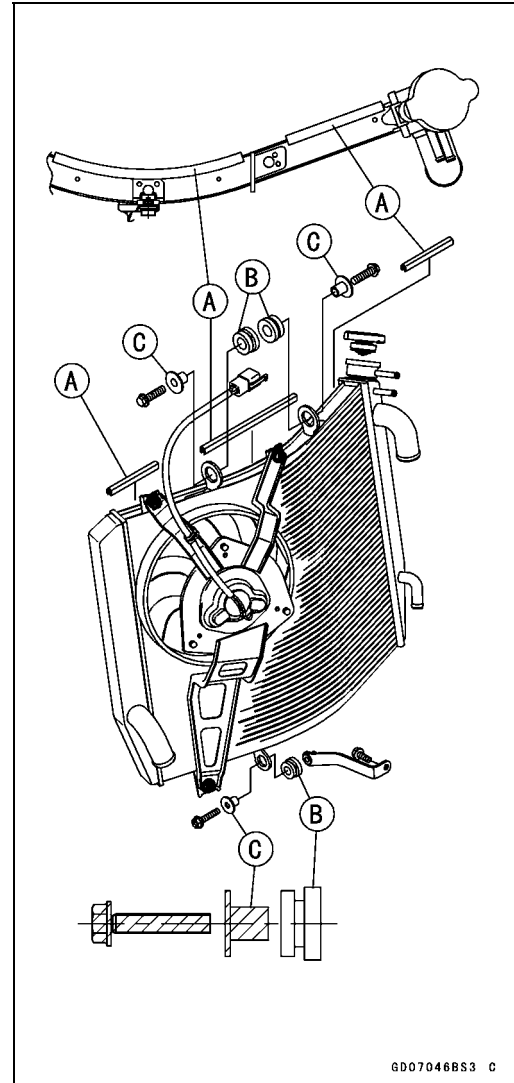

Radiator Inspection

- Check the radiator core.
- ★ If there are obstructions to air flow, remove them.
- ★ If the corrugated fins [A] are deformed, carefully straighten them.
- ★ If the air passages of the radiator core are blocked more than 20% by unremovable obstructions or irreparably deformed fins, replace the radiator with a new one.

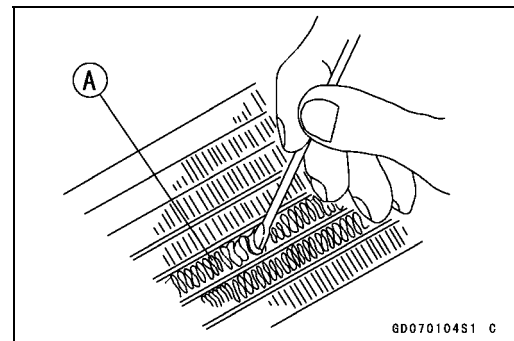

CAUTION

When cleaning the radiator with steam cleaner, be careful of the following to prevent radiator damage:
Keep the steam gun [A] away more than 0.5 m (1.6 ft) [B] from the radiator core.
Hold the steam gun perpendicular [C] (not oblique [D]) to the core surface.
Run the steam gun, following the core fin direction.

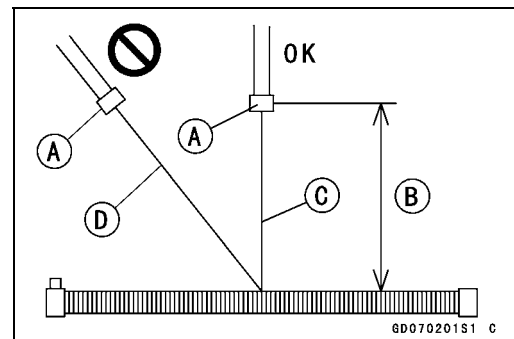

Radiator

Radiator Cap Inspection

- Remove:
 - Right Middle Fairing (see Middle Fairing Removal in the Frame chapter)
 - Radiator Cap
- Check the condition of the bottom [A] and top [B] valve seals and valve spring [C].
- ★ If any one of them shows visible damage, replace the cap with a new one.

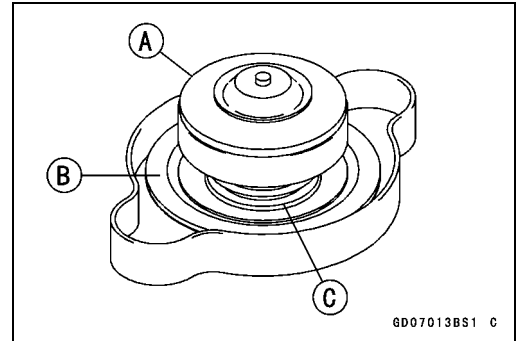

- Install the cap [A] on a cooling system pressure tester [B].

NOTE

○Wet the cap sealing surfaces with water or coolant to prevent pressure leaks.

- Watching the pressure gauge, pump the pressure tester to build up the pressure until the relief valve opens: the gauge needle flicks downward. Stop pumping and measure leak time at once. The relief valve must open within the specified range in the table below and the gauge hand must remain within the same range at least 6 seconds.

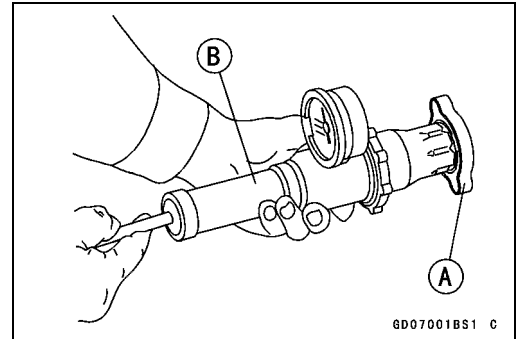

Radiator Cap Relief Pressure

Standard: 93 ~ 123 kPa (0.95 ~ 1.25 kgf/cm², 13 ~ 18 psi)

- ★ If the cap can not hold the specified pressure or if it holds too much pressure, replace it with a new one.

Radiator Filler Neck Inspection

- Remove the right middle fairing (see Middle Fairing Removal in the Frame chapter).
- Remove the radiator cap.
- Check the radiator filler neck for signs of damage.
- Check the condition of the top and bottom sealing seats [A] in the filler neck. They must be smooth and clean for the radiator cap to function properly.

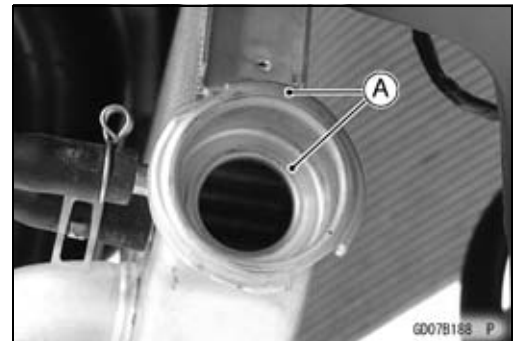

4-14 COOLING SYSTEM

Thermostat

Thermostat Removal

- Drain the coolant (see Coolant Change in the Periodic Maintenance chapter).
- Remove:
 - Fuel Tank (see Fuel Tank Removal in the Fuel System (DFI) chapter)
 - Throttle Body Assy (see Throttle Body Assy Removal in the Fuel System (DFI) chapter)
 - Thermostat Housing Mounting Bolts [A]
 - Radiator Hose [B]
 - Air Bleeder Hoses [C]
 - Thermostat Housing [D]
- Remove:
 - Thermostat Housing Cover Bolts [A]
 - Thermostat Housing Cover [B]
 - Thermostat

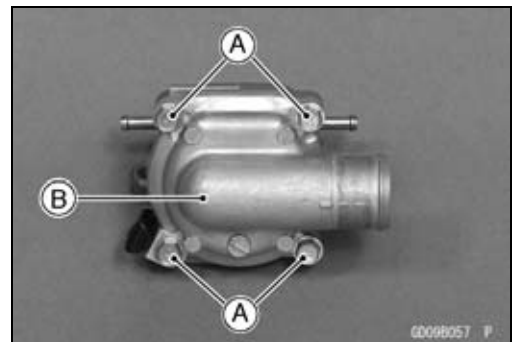
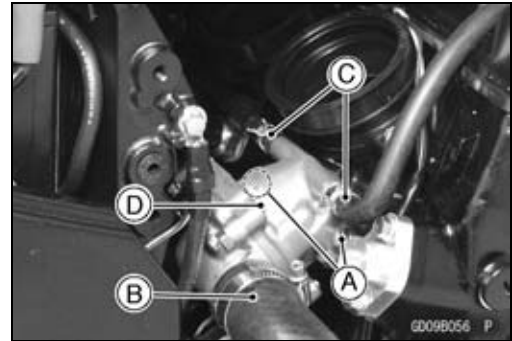

Thermostat Installation

- Install the thermostat [A] in the housing so that the air bleeder hole [B] is on top.
- Install a new O-ring into the housing.
- Tighten the thermostat housing cover bolts and the thermostat housing mounting bolts.

Torque - Thermostat Housing Cover Bolts: 5.9 N·m (0.60 kgf·m, 52 in·lb)

Thermostat Housing Mounting Bolts: 9.8 N·m (1.0 kgf·m, 87 in·lb)

- Fill the radiator with coolant (see Coolant Change in the Periodic Maintenance chapter).

Thermostat Inspection

- Remove the thermostat, and inspect the thermostat valve [A] at room temperature.
- ★ If the valve is open, replace the thermostat with a new one.

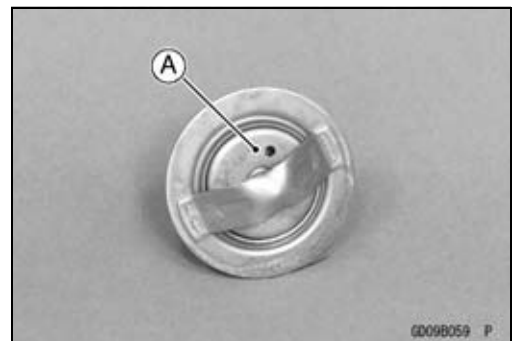
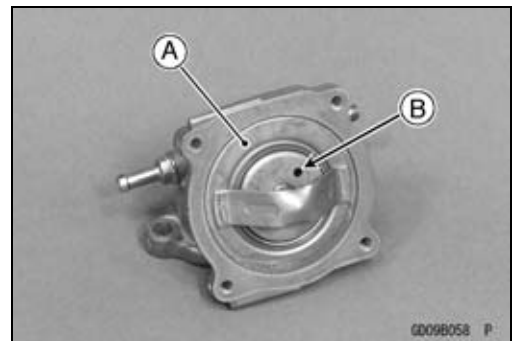

Thermostat

- To check valve opening temperature, suspend the thermostat [A] in a container of water and raise the temperature of the water.
- The thermostat must be completely submerged and must not touch the container sides or bottom. Suspend an accurate thermometer [B] in the water so that the heat sensitive portions [C] are located in almost the same depth. It must not touch the container, either.
- ★ If the measurement is out of the specified range, replace the thermostat with a new one.

Thermostat Valve Opening Temperature
58 ~ 62°C (136 ~ 144°F)

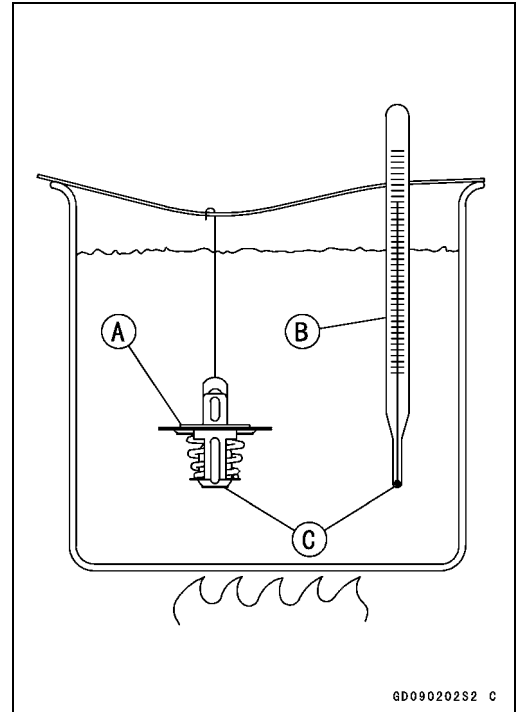

GD090202S2 C

4-16 COOLING SYSTEM

Hoses and Pipes

Hose Installation

- Install the hoses and pipes, being careful to follow bending direction. Avoid sharp bending, kinking, flattening or twisting.
- Run the hoses (see Cable, Wire, and Hose Routing section in the Appendix chapter).
- Install the clamp [A] as near as possible to the hose end to clear the raised rib of the fitting. This will prevent the hoses from working loose.
- The clamp screws should be positioned correctly to prevent the clamps from contacting the other parts.

Torque - Radiator Hose Clamp Screws: 2.0 N·m (0.20 kgf·m, 18 in·lb)

Hose Inspection

- Refer to the Radiator Hose and Connection Inspection in the Periodic Maintenance chapter.

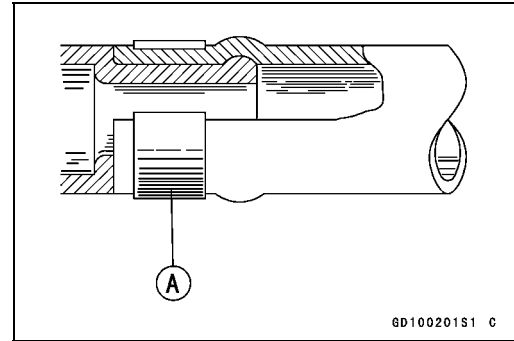

Water Temperature Sensor

CAUTION

The water temperature sensor should never be allowed to fall on a hard surface. Such a shock to their parts can damage them.

Water Temperature Sensor Removal

- Refer to the Water Temperature Sensor Removal in the Fuel System (DFI) chapter.
Water Temperature Sensor [A]

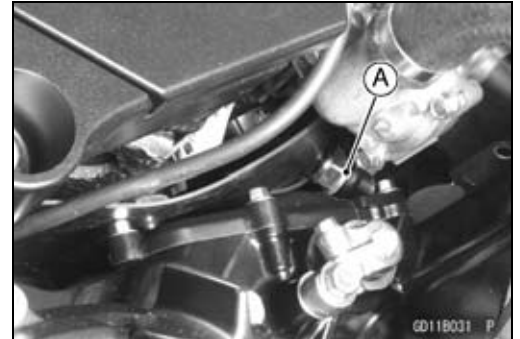

Water Temperature Sensor Inspection

- Refer to the Water Temperature Sensor Inspection in the Electrical System chapter.

Engine Top End

Table of Contents

Exploded View	5-2
Exhaust System.....	5-6
Specifications	5-8
Special Tools and Sealant	5-9
Clean Air System.....	5-11
Air Suction Valve Removal.....	5-11
Air Suction Valve Installation.....	5-11
Air Suction Valve Inspection	5-12
Air Switching Valve Removal	5-12
Air Switching Valve Installation	5-12
Air Switching Valve Operation Test.....	5-12
Air Switching Valve Unit Test	5-12
Clean Air System Hose Inspection	5-12
Cylinder Head Cover	5-13
Cylinder Head Cover Removal	5-13
Cylinder Head Cover Installation	5-13
Camshaft Chain Tensioner	5-15
Camshaft Chain Tensioner Removal	5-15
Camshaft Chain Tensioner Installation	5-15
Camshaft, Camshaft Chain	5-17
Camshaft Removal	5-17
Camshaft Installation	5-17
Camshaft, Camshaft Cap Wear	5-20
Camshaft Runout.....	5-21
Cam Wear.....	5-21
Camshaft Chain Removal.....	5-21
Camshaft Chain Installation.....	5-22
Cylinder Head.....	5-23
Cylinder Compression Measurement.....	5-23
Cylinder Head Removal.....	5-24
Cylinder Head Installation.....	5-24
Cylinder Head Warp.....	5-25
Valves	5-26
Valve Clearance Inspection	5-26
Valve Removal	5-26
Valve Installation	5-26
Valve Guide Removal	5-26
Valve Guide Installation	5-27
Valve-to-Guide Clearance Measurement (Wobble Method)	5-28
Valve Seat Inspection	5-29
Valve Seat Repair	5-29
Throttle Body Holder.....	5-34
Throttle Body Holder Installation.....	5-34
Muffler.....	5-35
Muffler Body Removal/Installation	5-35
Exhaust Pipe Removal.....	5-36
Exhaust Pipe Installation.....	5-36

5-2 ENGINE TOP END

Exploded View

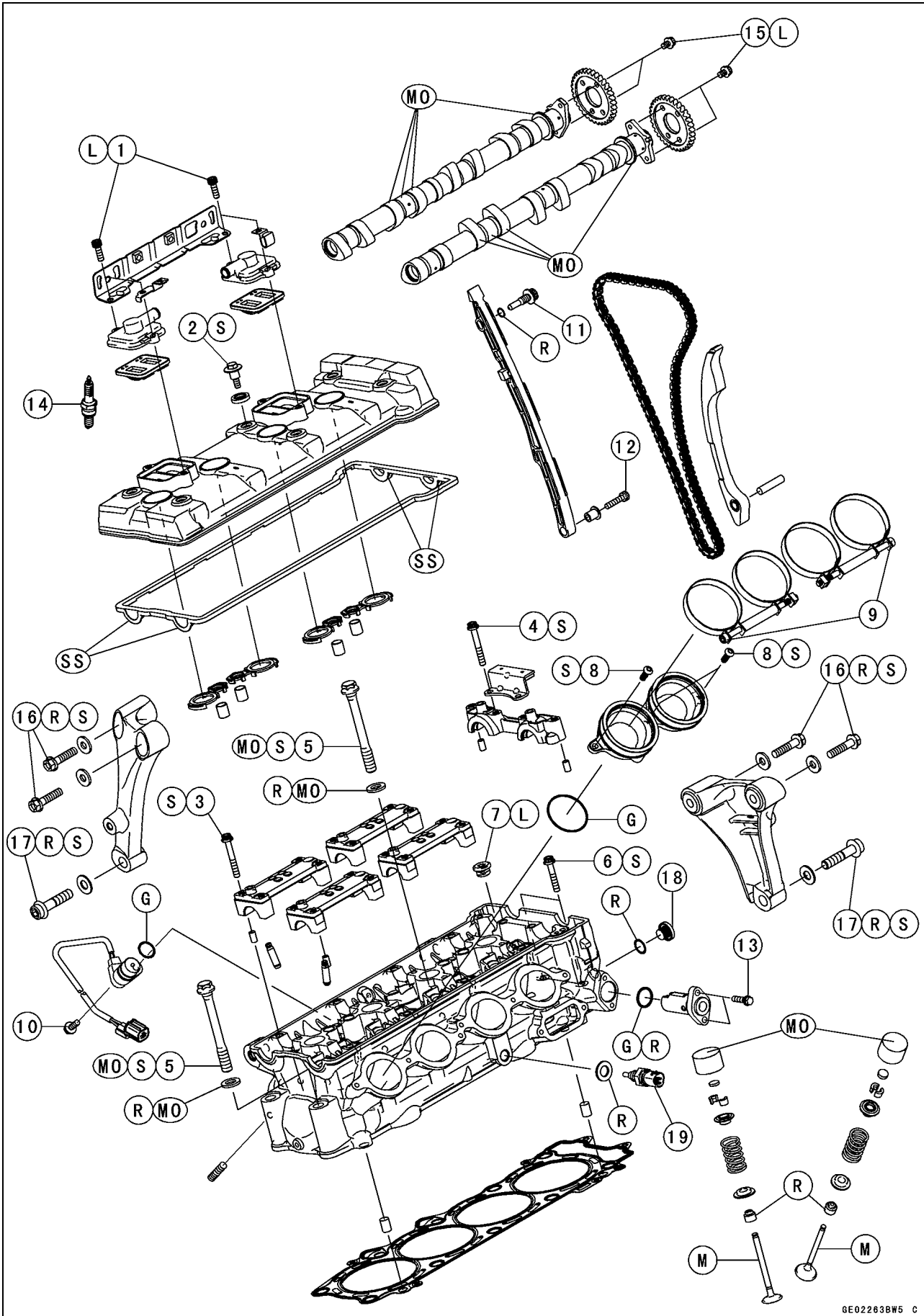

Exploded View

No.	Fastener	Torque			Remarks
		N·m	kgf·m	ft·lb	
1	Air Suction Valve Cover Bolts	9.8	1.0	87 in·lb	L
2	Cylinder Head Cover Bolts	9.8	1.0	87 in·lb	S
3	Camshaft Cap Bolts	12	1.2	106 in·lb	S
4	Camshaft Chain Guide Bolts	12	1.2	106 in·lb	S
5	Cylinder Head Bolts (M11, First)	39	4.0	29	MO, S
	Cylinder Head Bolts (M11, Final)	71	7.2	52	MO, S
6	Cylinder Head Bolts (M6)	12	1.2	106 in·lb	S
7	Water Passage Plugs	20	2.0	15	L
8	Throttle Body Holder Bolts	9.8	1.0	87 in·lb	S
9	Throttle Body Assy Holder Clamp Bolts	2.0	0.20	18 in·lb	
10	Camshaft Position Sensor Bolt	9.8	1.0	87 in·lb	
11	Front Camshaft Chain Guide Bolt (Upper)	25	2.5	18	
12	Front Camshaft Chain Guide Bolt (Lower)	12	1.2	106 in·lb	
13	Camshaft Chain Tensioner Mounting Bolts	9.8	1.0	87 in·lb	
14	Spark Plugs	13	1.3	115 in·lb	
15	Cam Sprocket Mounting Bolts	15	1.5	11	L
16	Engine Bracket Bolts	25	2.5	18	R, S
17	Front Engine Mounting Bolts	59	6.0	44	R, S
18	Plug	–	–	–	Hand-tighten
19	Water Temperature Sensor	25	2.5	18	

G: Apply grease.

L: Apply a non-permanent locking agent.

M: Apply molybdenum disulfide grease.

MO: Apply molybdenum disulfide oil.

(mixture of the engine oil and molybdenum disulfide grease in a weight ratio 10 : 1)

R: Replacement Parts

S: Follow the specific tightening sequence.

SS: Apply silicone sealant (Kawasaki Bond: 92104-0004).

5-4 ENGINE TOP END

Exploded View

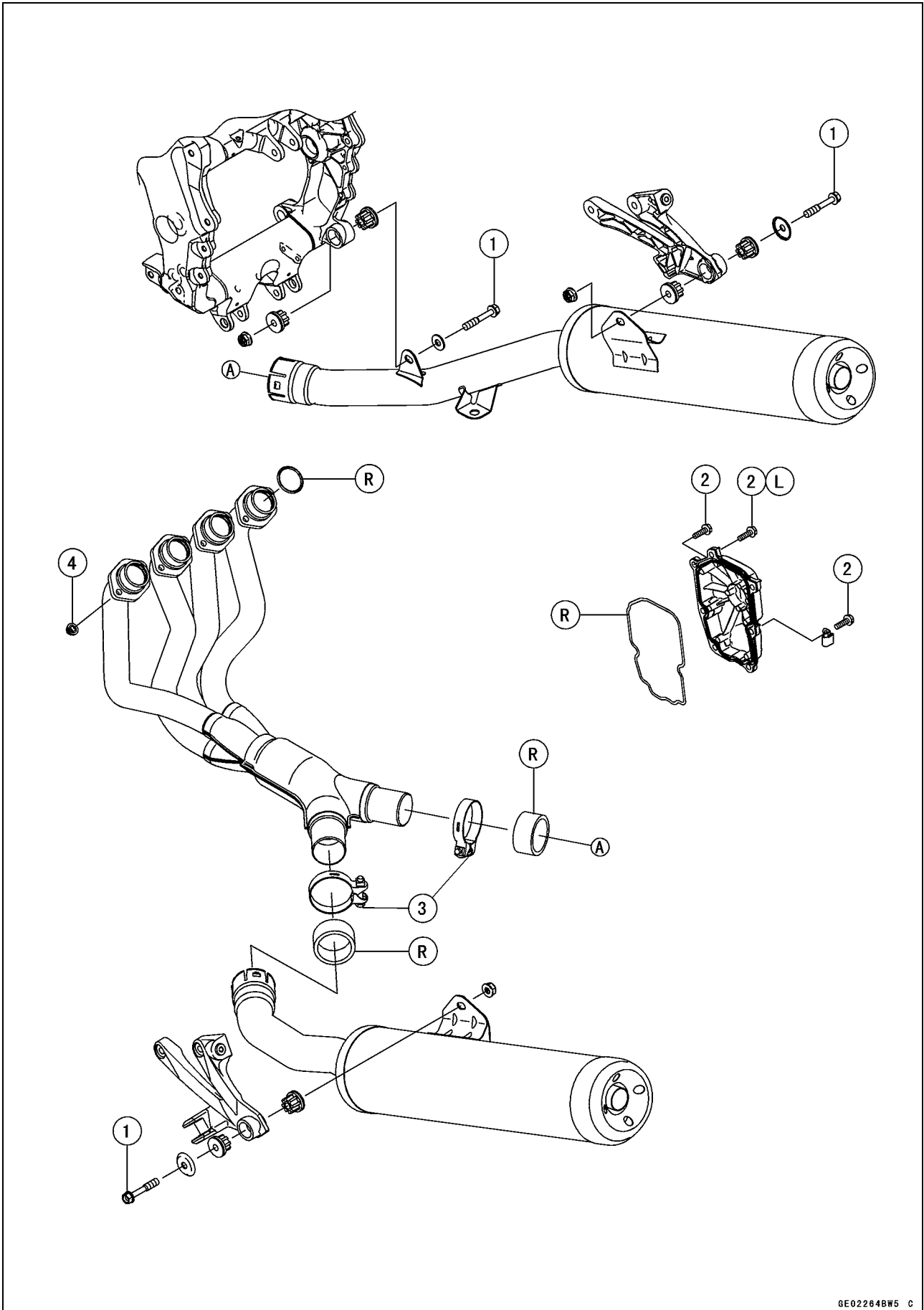

Exploded View

No.	Fastener	Torque			Remarks
		N·m	kgf·m	ft·lb	
1	Muffler Body Mounting Bolts	34	3.5	25	
2	Crankshaft Sensor Cover Bolts	9.8	1.0	87 in·lb	L (1)

3. Muffler Body Clamp Bolts

4. Exhaust Pipe Manifold Holder Nuts

L: Apply a non-permanent locking agent.

R: Replacement Parts

5-6 ENGINE TOP END

Exhaust System

MANIFOLD	SILENCER	SPECIFICATION	MARKETING CODE
<div style="border: 1px solid black; padding: 5px; width: fit-content;"> Non-Catalyst P/No. 39178-0054 Mark: KHI M104 </div>	<div style="border: 1px solid black; padding: 5px; width: fit-content;"> Honeycomb Type Catalyst P/No. 18091-0350 P/No. 18091-0352 Mark: KHI K 501 EPA Noise Emission Control Information </div>	WVTA (FULL H) GB WVTA (FULL H) WVTA (78.2H) U.S.A U.S.A (CALIF) Canada Australia	ZX1400A6F/ZX1400B6F ZX1400A6F/ZX1400B6F ZX1400A6F/ZX1400B6F ZX1400A6F ZX1400A6F ZX1400A6F ZX1400A6F
	<div style="border: 1px solid black; padding: 5px; width: fit-content;"> Honeycomb Type Catalyst P/No. 18091-0354 P/No. 18091-0356 Mark: KHI K 503 EPA Noise Emission Control Information </div>	Malaysia	ZX1400A6F/ZX1400B6F

GE24019B F

Full: Full Power
 H: Honeycomb Type Catalyst
 78.2: Hosepower 78.2 kW (106.3 ps)
 Manifold Mark Position [A]

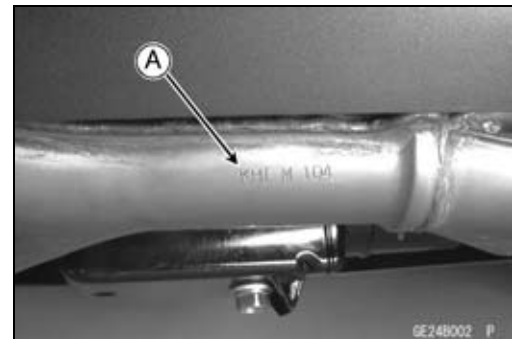

GE248002 P

Exhaust System

Silencer Mark Position [A]



Honeycomb Type Catalyst [A]

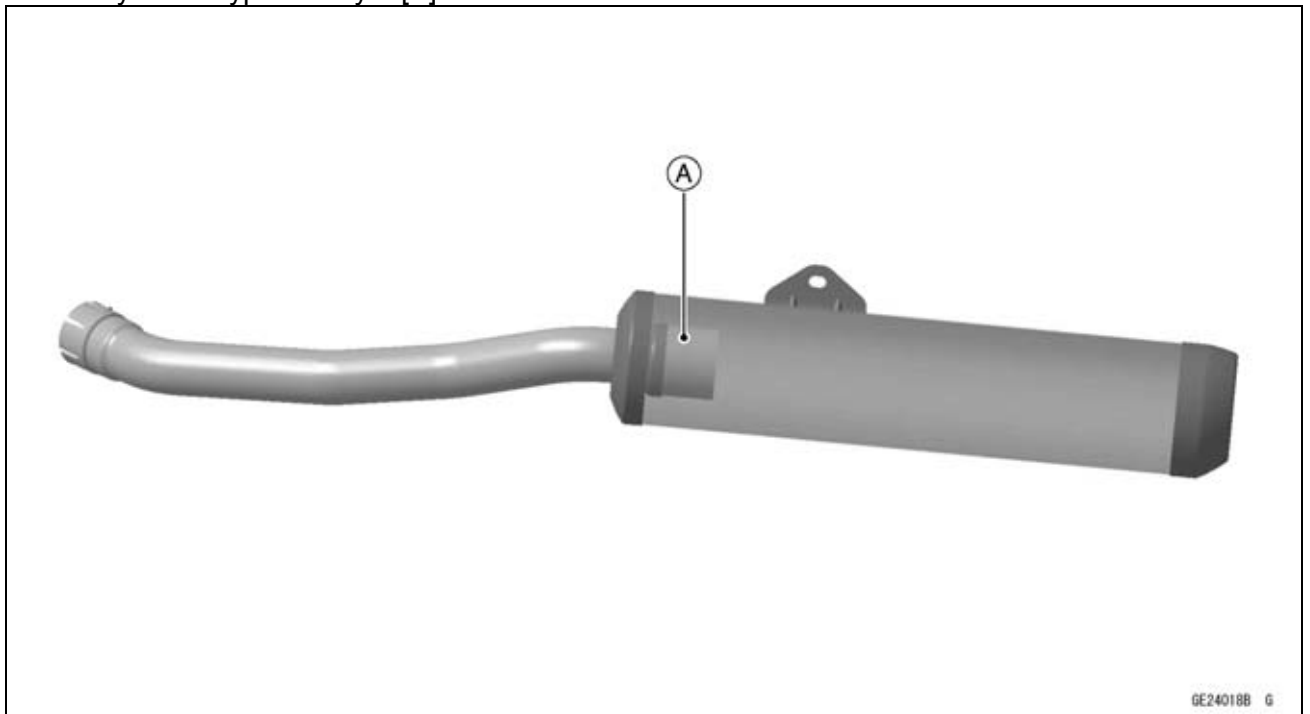

5-8 ENGINE TOP END

Specifications

Item	Standard	Service Limit
Camshafts		
Cam Height:		
Exhaust	34.442 ~ 34.556 mm (1.3560 ~ 1.3605 in.)	34.34 mm (1.352 in.)
Inlet	34.943 ~ 35.057 mm (1.3757 ~ 1.3802 in.)	34.84 mm (1.372 in.)
Camshaft Journal, Camshaft Cap Clearance	0.038 ~ 0.081 mm (0.0015 ~ 0.0032 in.)	0.17 mm (0.0067 in.)
Camshaft Journal Diameter	23.940 ~ 23.962 mm (0.9425 ~ 0.9434 in.)	23.91 mm (0.941 in.)
Camshaft Bearing Inside Diameter	24.000 ~ 24.021 mm (0.9449 ~ 0.9457 in.)	24.08 mm (0.948 in.)
Camshaft Runout	TIR 0.02 mm (0.0008 in.) or less	TIR 0.1 mm (0.004 in.)
Cylinder Head		
Cylinder Compression	(Usable Range) 1 030 ~ 1 569 kPa (10.5 ~ 16.0 kgf/cm ² , 149 ~ 228 psi) @300 r/min (rpm)	— — —
Cylinder Head Warp	— — —	0.05 mm (0.002 in.)
Valves		
Valve Clearance:		
Exhaust	0.22 ~ 0.27 mm (0.0087 ~ 0.0106 in.)	— — —
Inlet	0.15 ~ 0.20 mm (0.0059 ~ 0.0079 in.)	— — —
Valve Head Thickness:		
Exhaust	0.8 mm (0.031 in.)	0.7 mm (0.0276 in.)
Inlet	0.5 mm (0.020 in.)	0.25 mm (0.001 in.)
Valve Stem Bend	TIR 0.01 mm (0.0004 in.) or less	TIR 0.05 mm (0.002 in.)
Valve Stem Diameter:		
Exhaust	4.955 ~ 4.970 mm (0.1951 ~ 0.1957 in.)	4.94 mm (0.194 in.)
Inlet	4.975 ~ 4.990 mm (0.1959 ~ 0.1965 in.)	4.96 mm (0.195 in.)
Valve Guide Inside Diameter:		
Exhaust	5.000 ~ 5.012 mm (0.1969 ~ 0.1973 in.)	5.077 mm (0.200 in.)
Inlet	5.000 ~ 5.012 mm (0.1969 ~ 0.1973 in.)	5.077 mm (0.200 in.)
Valve/valve Guide Clearance (Wobble Method):		
Exhaust	0.10 ~ 0.18 mm (0.0039 ~ 0.0071 in.)	0.39 mm (0.015 in.)
Inlet	0.03 ~ 0.12 mm (0.0012 ~ 0.0047 in.)	0.33 mm (0.013 in.)
Valve Seat Cutting Angle	45°, 32°, 60°	— — —
Valve Seating Surface:		
Width:		
Exhaust	0.8 ~ 1.2 mm (0.031 ~ 0.047 in.)	— — —
Inlet	0.5 ~ 1.0 mm (0.020 ~ 0.039 in.)	— — —
Outside Diameter:		
Exhaust	27.6 ~ 27.8 mm (1.087 ~ 1.094 in.)	— — —
Inlet	32.6 ~ 32.8 mm (1.283 ~ 1.291 in.)	— — —
Valve Spring Free Length:		
Exhaust	39.10 mm (1.539 in.)	37.4 mm (1.472 in.)
Inlet	38.72 mm (1.524 in.)	37.1 mm (1.461 in.)

Special Tools and Sealant

Compression Gauge, 20 kgf/cm²:
57001-221

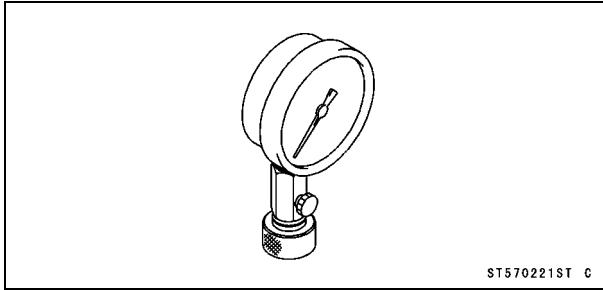

Valve Seat Cutter, 60° - ϕ 30:
57001-1123

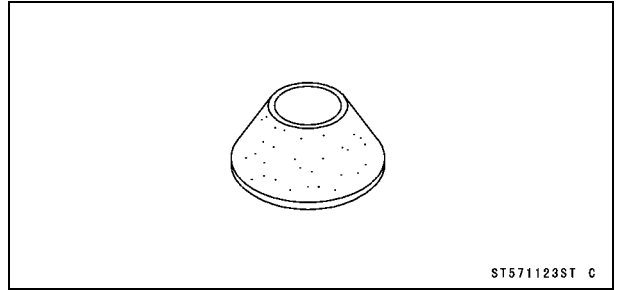

Valve Spring Compressor Assembly:
57001-241

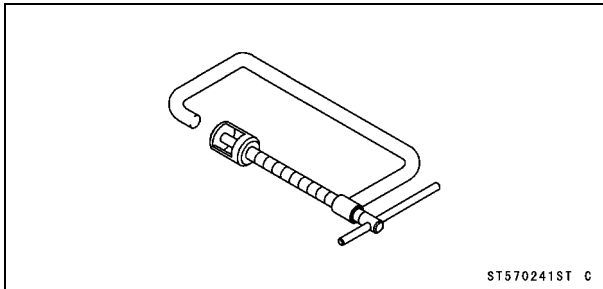

Valve Seat Cutter Holder Bar:
57001-1128

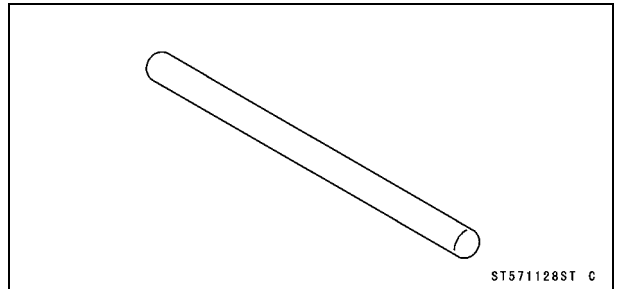

Valve Seat Cutter, 45° - ϕ 35:
57001-1116

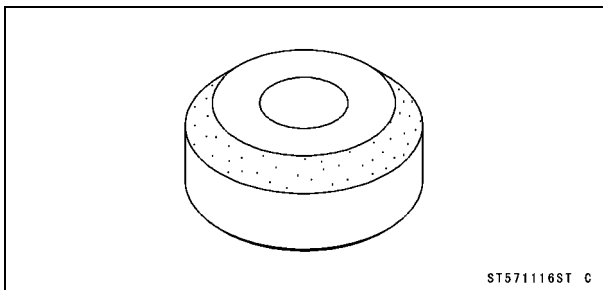

Valve Seat Cutter, 45° - ϕ 30:
57001-1187

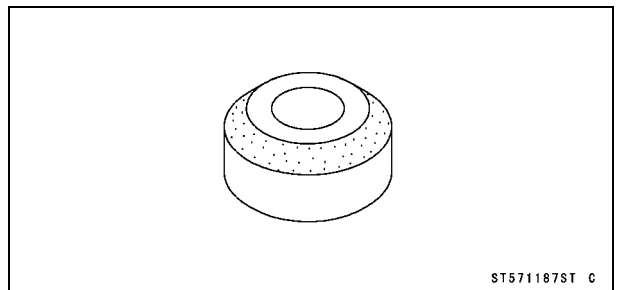

Valve Seat Cutter, 32° - ϕ 30:
57001-1120

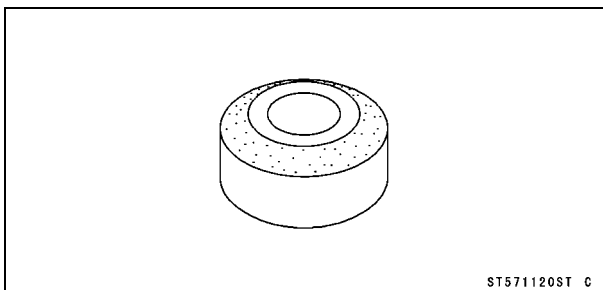

Valve Guide Arbor, ϕ 5:
57001-1203

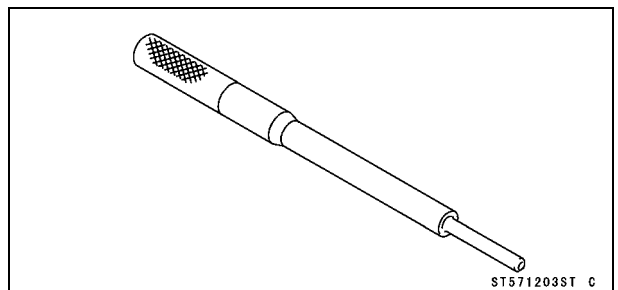

Valve Seat Cutter, 32° - ϕ 35:
57001-1121

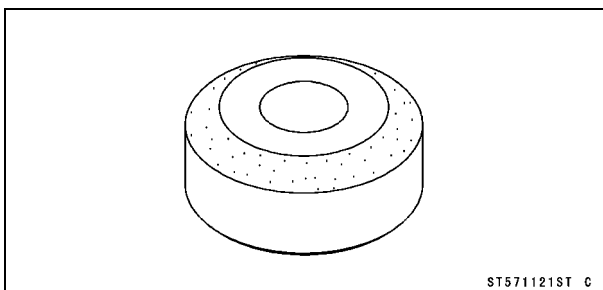

Valve Guide Reamer, ϕ 5:
57001-1204

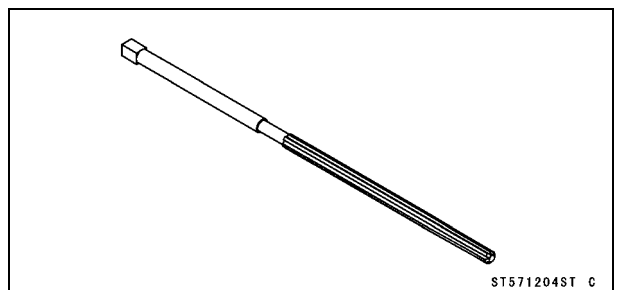

5-10 ENGINE TOP END

Special Tools and Sealant

Valve Seat Cutter Holder, $\phi 5$:
57001-1208

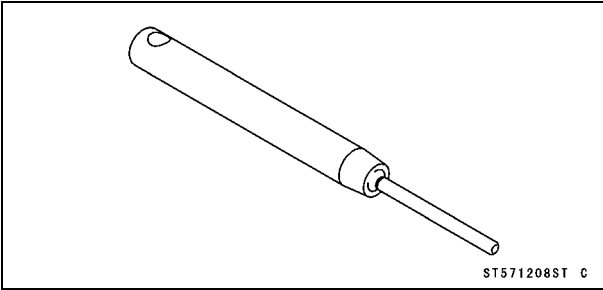

Compression Gauge Adapter, M10 \times 1.0:
57001-1601

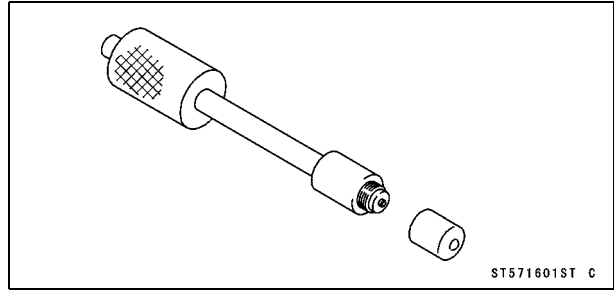

Valve Seat Cutter, 60° - $\phi 33$:
57001-1334

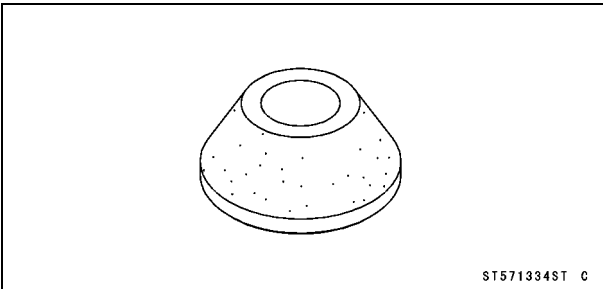

L-Shape Hose:
57001-1606

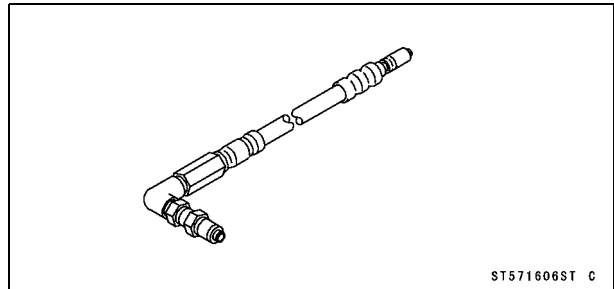

Valve Guide Driver:
57001-1564

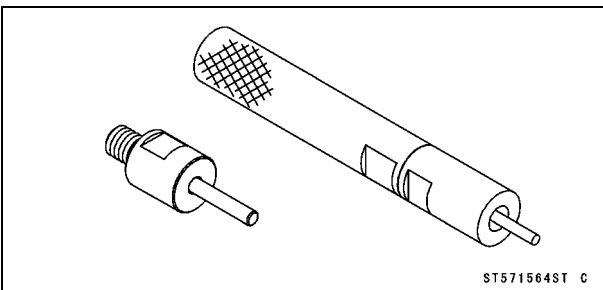

Valve Guide Driver Attachment, E:
57001-1677

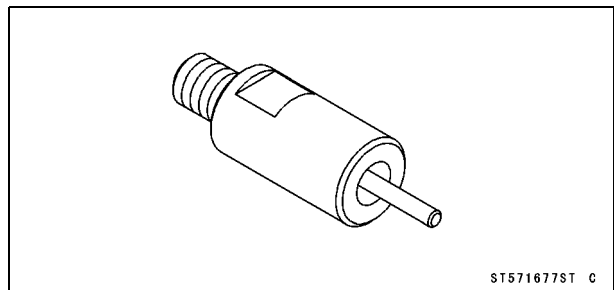

Valve Spring Compressor Adapter, $\phi 24$:
57001-1586

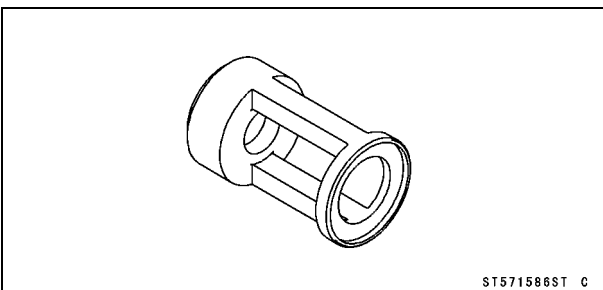

Kawasaki Bond (Silicone Sealant):
92104-0004

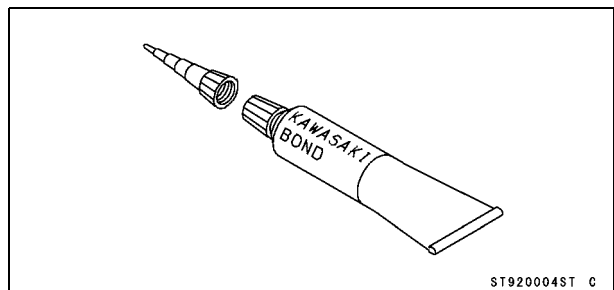

Clean Air System

Air Suction Valve Removal

- Remove:
 - Middle Fairings (see Middle Fairing Removal in the Frame chapter)
- Pull out the hoses [A].
- Disconnect the connector [B].
- Remove the air switching valve [C] with the hoses.

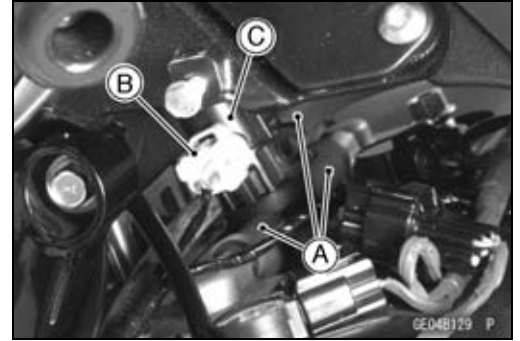

- Remove the following from the bracket [A].
 - Rivets [B]
 - Bolts [C]

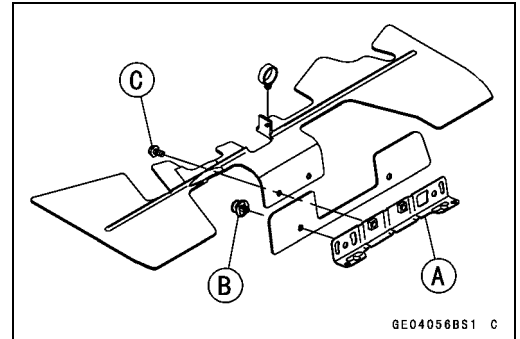

- Remove:
 - Air Suction Valve Cover Bolts [A]
 - Air Suction Valve Cover [B]
 - Air Suction Valve [C]

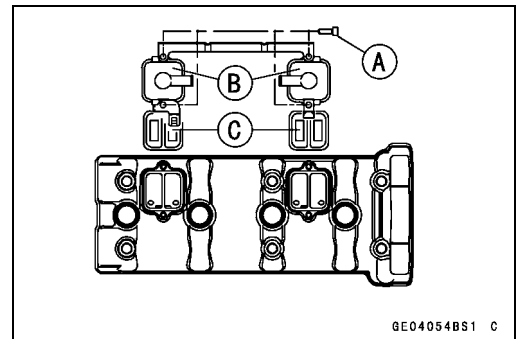

Air Suction Valve Installation

- Install the air suction valve so that opening [A] of the reed faces the rear and downward.
- Apply a non-permanent locking agent to the threads of the air suction valve cover bolts, and tighten them with the specified torque.

Torque - Air Suction Valve Cover Bolts: 9.8 N·m (1.0 kgf·m, 87 in·lb)

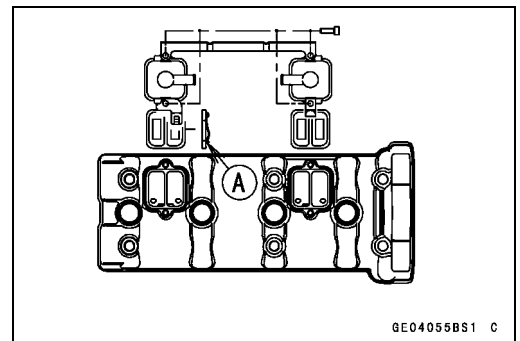

5-12 ENGINE TOP END

Clean Air System

Air Suction Valve Inspection

- Remove the air suction valve (see Air Suction Valve Removal).
- Visually inspect the reeds [A] for cracks, folds, warps, heat damage, or other damage.
- ★ If there is any doubt as to the condition of the reed, replace the air suction valve as an assembly.
- Check the reed contact areas [B] of the valve holder for grooves, scratches, any signs of separation from the holder, or heat damage.
- ★ If there is any doubt as to the condition of the reed contact areas, replace the air suction valve as an assembly.
- If any carbon or other foreign particles have accumulated between the reed and the reed contact area, wash the valve assembly with a high flash-point solvent.

CAUTION

Do not scrape off the deposits with a scraper as this could damage the rubber, requiring replacement of the suction valve assembly.

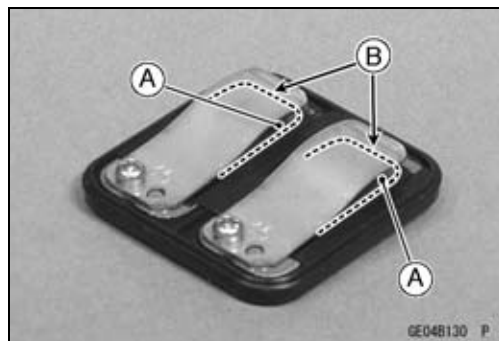

Air Switching Valve Removal

- Remove:
 - Middle Fairings (see Middle Fairing Removal in the Frame chapter)
 - Connector [A]
 - Air Switching Valve [B]

CAUTION

Never drop the switch especially on a hard surface. Such a shock to the switch can damage it.

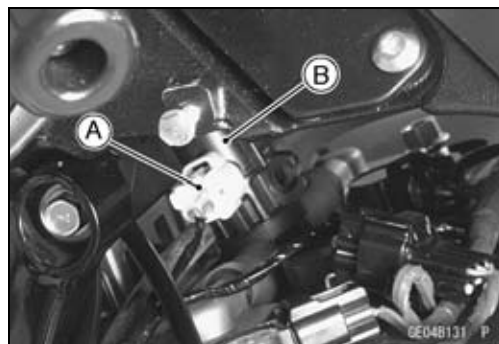

Air Switching Valve Installation

- Install the air switching valve so that the air duct [A] faces left side.
- Route the hoses correctly (see Cable, Wire, and Hose Routing section in the Appendix chapter).

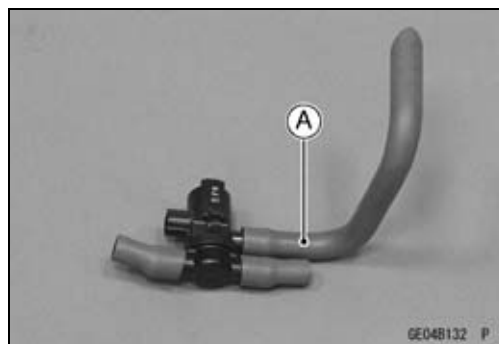

Air Switching Valve Operation Test

- Refer to the Air Switching Valve Operation Test in the Electrical System chapter.

Air Switching Valve Unit Test

- Refer to the Air Switching Valve Unit Test in the Electrical System chapter.

Clean Air System Hose Inspection

- Be certain that all the hoses are routed without being flattened or kinked, and are connected correctly to the air cleaner housing, air switching valve and air suction valve covers.
- ★ If they are not, correct them. Replace them if they are damaged.

Cylinder Head Cover

Cylinder Head Cover Removal

- Remove:
 - Middle Fairings (see Middle Fairing Removal in the Frame chapter)
 - Throttle Body Assy (see Throttle Body Assy Removal in the Fuel System (DFI) chapter)
 - Air Switching Valve (see Air Switching Valve Removal)
- Free the heat insulation rubber plate.
- Remove:
 - Stick Coils (see Stick Coil (Ignition Coil together with Spark Plug Cap) Removal in the Electrical System chapter)
 - Air Suction Valve Covers (see Air Suction Valve Removal)
- Remove the cylinder head cover bolts [A].
- Remove the cylinder head cover to backward floating it a little up.

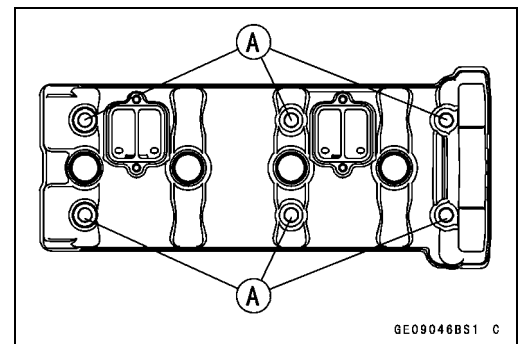

Cylinder Head Cover Installation

- Replace the head cover gasket with a new one.
- Apply silicone sealant [A] to the cylinder head as shown.
 - Sealant - Kawasaki Bond (Silicone Sealant): 92104-0004**

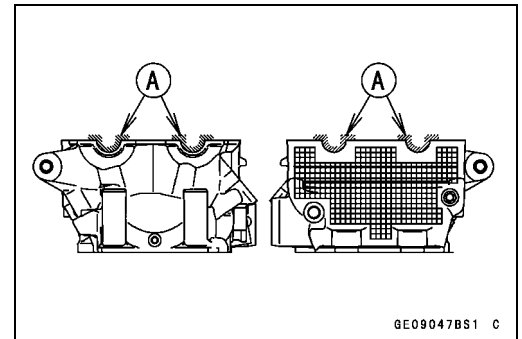

- Install:
 - Dowel Pins [A]
 - Plug Hole Gaskets [B]

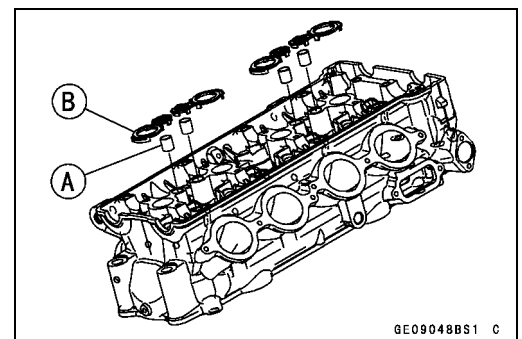

5-14 ENGINE TOP END

Cylinder Head Cover

- Install the washer [A] with the metal side faces upward.
- Tighten the cover bolts, following the sequence numbers on the cover.

Torque - Cylinder Head Cover Bolts [B]: 9.8 N·m (1.0 kgf·m, 87 in·lb)

- Install the removed parts (see appropriate chapters).

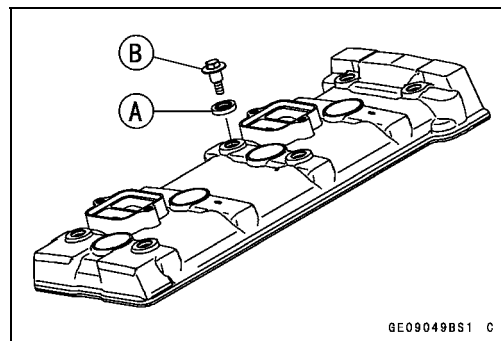

Camshaft Chain Tensioner

Camshaft Chain Tensioner Removal

CAUTION

Do not turn over the crankshaft while the tensioner is removed. This could upset the camshaft chain timing, and damage the valves.

- Remove the right middle fairing (see Middle Fairing Removal in the Frame chapter).
- Remove the mounting bolts [A] and take off the camshaft chain tensioner [B].

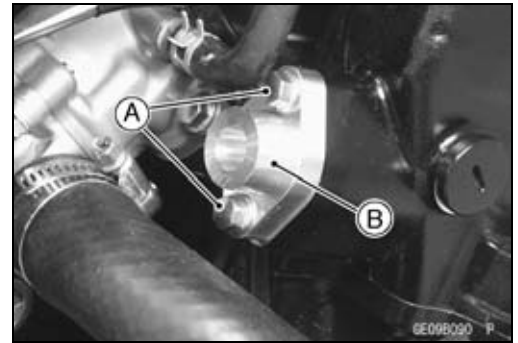

Camshaft Chain Tensioner Installation

- Remove the cylinder head cover (see Cylinder Head Cover Removal).
- Pinching [A] the stopper [B], release it and push [C] the push rod [D] into the interior of tensioner body [E].

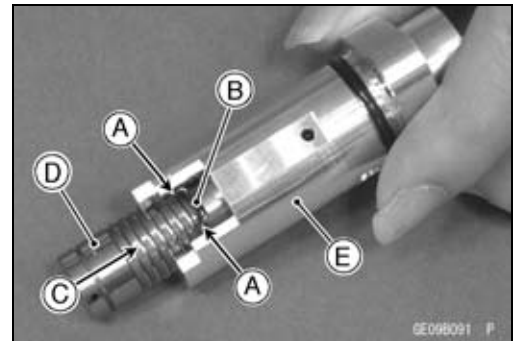

- Pushing [A] the push rod, slide the snap ring [B] into the groove [C] of smaller diameter from the groove [D] of larger diameter.

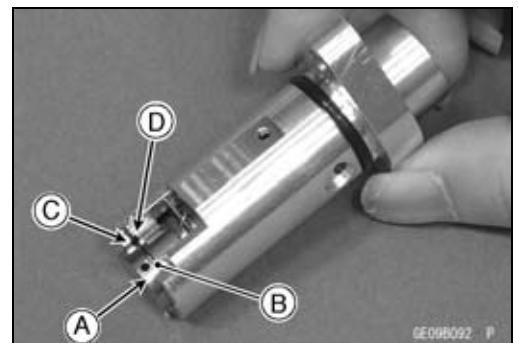

- Install the tensioner body so that the stopper [A] faces upward.
- Tighten the tensioner mounting bolts.

Torque - Camshaft Chain Tensioner Mounting Bolts: 9.8 N·m (1.0 kgf·m, 87 in·lb)



5-16 ENGINE TOP END

Camshaft Chain Tensioner

- Lightly hit the push rod head [A] with a minus screw driver [B] to move out the push rod.

NOTE

- *You hear of the sound from which the push rod moves out.*
- Turn the crankshaft 2 turns clockwise to allow the tensioner to expand and recheck the camshaft chain timing.

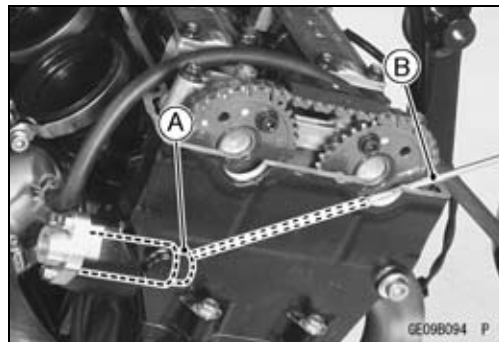

Camshaft, Camshaft Chain

Camshaft Removal

- Remove:
 - Cylinder Head Cover (see Cylinder Head Cover Removal)
 - Crankshaft Sensor Cover
- Position the crankshaft at #1, 4 piston TDC.
 - TDC mark [A] for #1, 4 Pistons
 - Timing Mark (crankcase halves mating surface) [B]

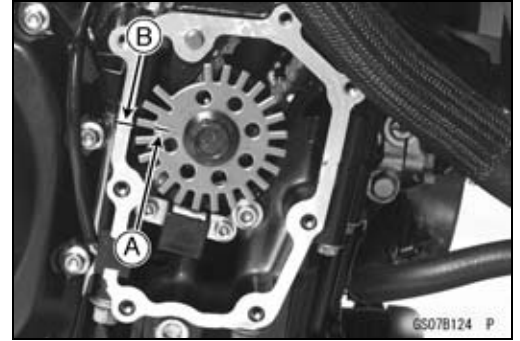

- Remove:
 - Camshaft Chain Tensioner (see Camshaft Chain Tensioner Removal)
 - Camshaft Cap Bolts [A]
 - Chain Guide
 - Camshaft Caps [B]
 - Camshafts [C]
- Stuff a clean cloth into the chain tunnel to keep any parts from dropping into the crankcase.

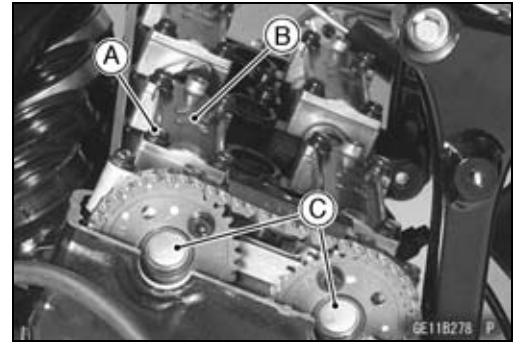

- Remove the cam sprocket mounting bolts [A].
- Remove the cam sprocket.

CAUTION

The crankshaft may be turned while the camshafts are removed. Always pull the chain taut while turning the crankshaft. This avoids kinking the chain on the lower (crankshaft) sprocket. A kinked chain could damage both the chain and the sprocket.

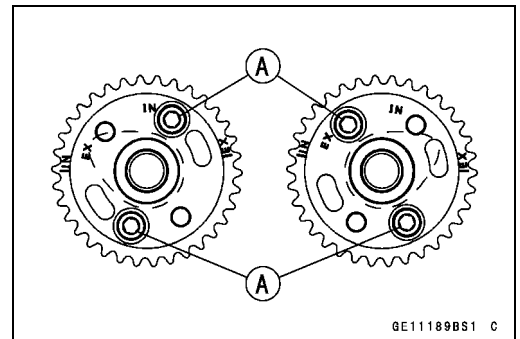

Camshaft Installation

- Be sure to install the following parts.
 - Plug Hole Gaskets [A]
 - Dowel Pins [B]

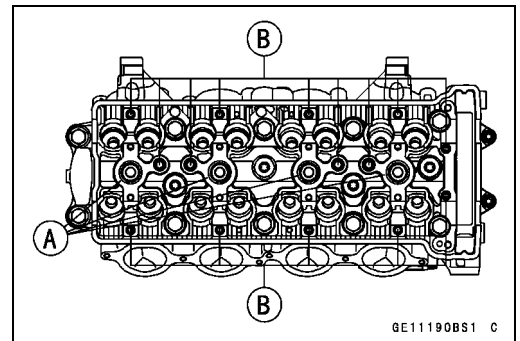

- Install the cam sprockets as shown in figure.
 - #4 Cam Positions [A]
 - Inlet Cam Sprocket [B]
 - Exhaust Cam Sprocket [C]
- Apply a non-permanent locking agent to the threads and tighten the bolts.

Torque - Cam Sprocket Mounting Bolts: 15 N·m (1.5 kgf·m, 11 ft·lb)

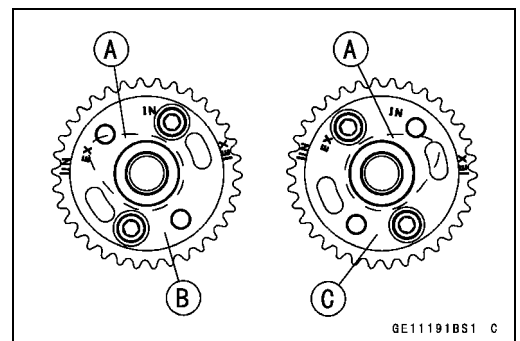

5-18 ENGINE TOP END

Camshaft, Camshaft Chain

- Apply engine oil to all cam parts and journals.
- If a new camshaft is to be used, apply a thin coat of molybdenum disulfide grease to the cam surfaces.

NOTE

- The exhaust camshaft has a 1090 EX mark [A] and the inlet camshaft has a 1090 IN mark [B]. Be careful not to mix up these shafts.

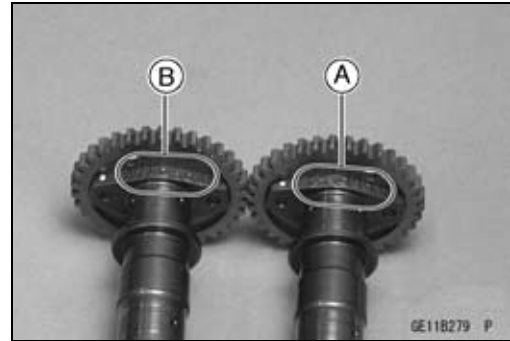

NOTE

- The exhaust camshaft has the projection [A] for camshaft position sensor.

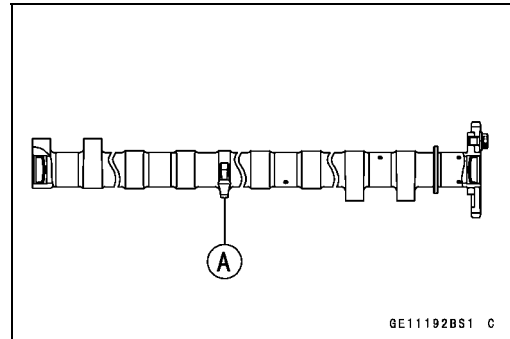

- Position the crankshaft at #1, 4 piston TDC.
- Pull the tension side (exhaust side) [A] of the chain taut to install the chain.
- Engage the camshaft chain with the camshaft sprockets so that the timing marks on the sprockets are positioned as shown.
- The timing marks of #1, 4T must be aligned with the lower surface of crankcase of rear side [B].

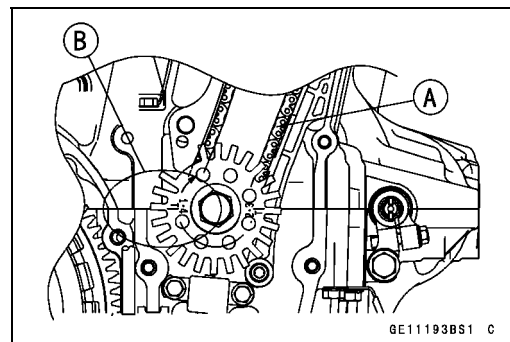

Camshaft, Camshaft Chain

- The timing marks must be aligned with the cylinder head upper surface [A].
EX mark [B]
IN mark [C]

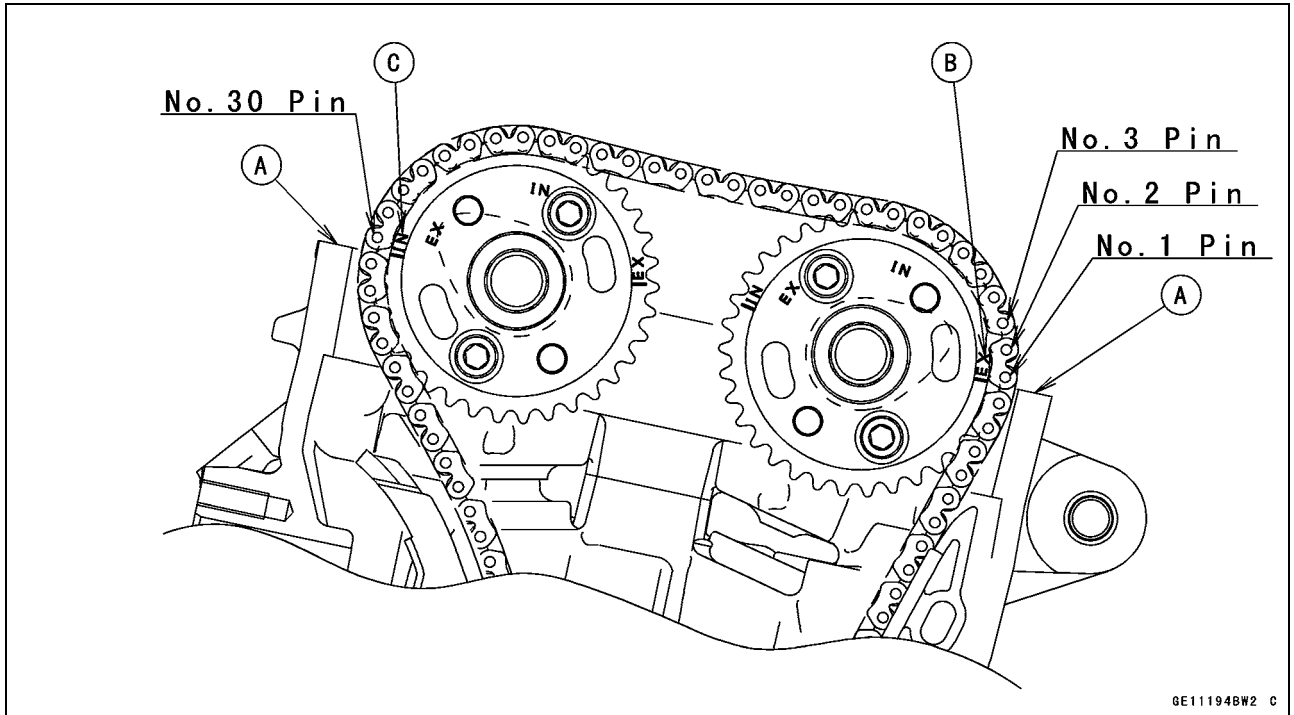

5-20 ENGINE TOP END

Camshaft, Camshaft Chain

- Install the camshaft cap, following the identification No. [A] and chain guide [B].
- First tighten the camshaft cap and all chain guide bolts evenly to seat the camshaft in place, then tighten all bolts following the specified tightening sequence.

Torque - Camshaft Cap Bolts (1 ~ 16, 17, 18): 12 N·m (1.2 kgf·m, 106 in·lb)

Camshaft Chain Guide Bolts (19, 20): 12 N·m (1.2 kgf·m, 106 in·lb)

- Install the camshaft chain tensioner (see Camshaft Chain Tensioner Installation).

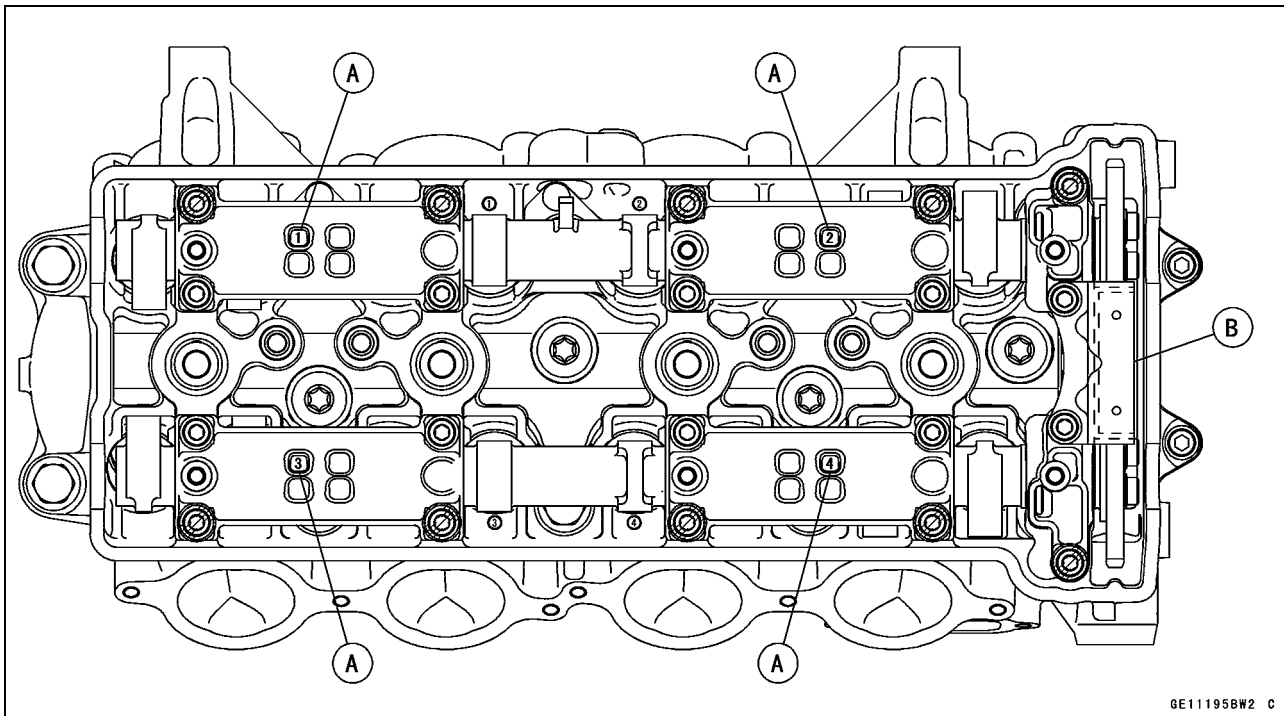

GE11195BW2 C

Camshaft, Camshaft Cap Wear

- Remove:
 - Camshaft Chain Guide
 - Camshaft Cap (see Camshaft Removal)
- Cut strips of plastigage to journal width. Place a strip on each journal parallel to the camshaft installed in the correct position.
- Measure each clearance between the camshaft journal and the camshaft cap using plastigage (press gauge) [A].

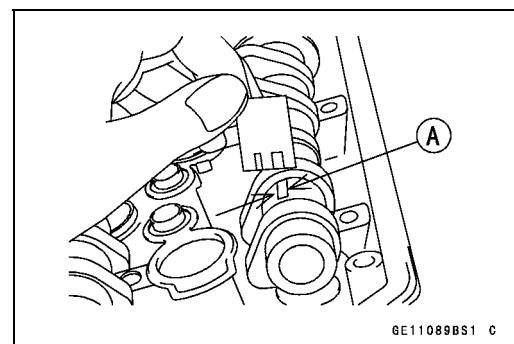

GE11089BS1 C

- Tighten:
 - Torque - Camshaft Cap Bolts: 12 N·m (1.2 kgf·m, 106 in·lb)**
 - Camshaft Chain Guide Bolts: 12 N·m (1.2 kgf·m, 106 in·lb) (see Camshaft Installation)**

NOTE

- Do not turn the camshaft when the plastigage is between the journal and camshaft cap.

Camshaft Journal, Camshaft Cap Clearance

Standard: 0.038 ~ 0.081 mm (0.0015 ~ 0.0032 in.)

Service Limit: 0.17 mm (0.0067 in.)

Camshaft, Camshaft Chain

- ★ If any clearance exceeds the service limit, measure the diameter of each camshaft journal with a micrometer.

Camshaft Journal Diameter

Standard: 23.940 ~ 23.962 mm (0.9425 ~ 0.9434 in.)

Service Limit: 23.91 mm (0.941 in.)

- ★ If the camshaft journal diameter is less than the service limit, replace the camshaft with a new one and measure the clearance again.
- ★ If the clearance still remains out of the limit, replace the cylinder head unit.

Camshaft Runout

- Remove the camshaft (see Camshaft Removal).
- Set the camshaft in a camshaft alignment jig or on V blocks.
- Measure runout with a dial gauge at the specified place as shown.
- ★ If the runout exceeds the service limit, replace the shaft.

Camshaft Runout

Standard: TIR 0.02 mm (0.0008 in.) or less

Service Limit: TIR 0.1 mm (0.004 in.)

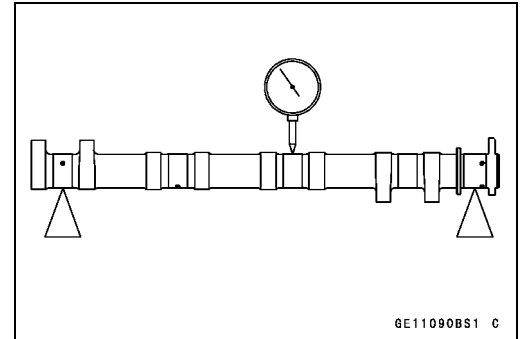

Cam Wear

- Remove the camshaft (see Camshaft Removal).
- Measure the height [A] of each cam with a micrometer.
- ★ If the cams are worn down past the service limit, replace the camshaft.

Cam Height

Standard:

Exhaust 34.442 ~ 34.556 mm (1.3560 ~ 1.3605 in.)

Inlet 34.943 ~ 35.057 mm (1.3757 ~ 1.3802 in.)

Service Limit:

Exhaust 34.34 mm (1.352 in.)

Inlet 34.84 mm (1.372 in.)

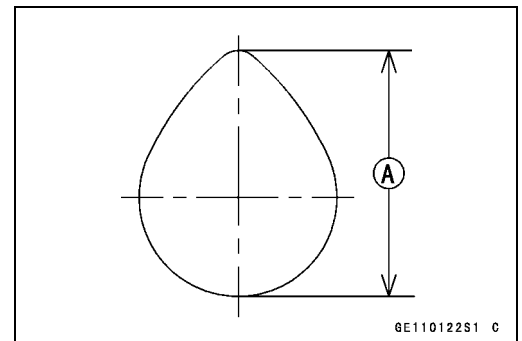

Camshaft Chain Removal

- Remove:
 - Camshafts (see Camshaft Removal)
 - Timing Rotor [A] (see Timing Rotor Removal in the Electrical System chapter)
 - Front Camshaft Chain Guide Bolts [B]
 - Front Camshaft Chain Guide [C]
 - Dowel Pin [D]
 - Rear Camshaft Chain Guide [E]

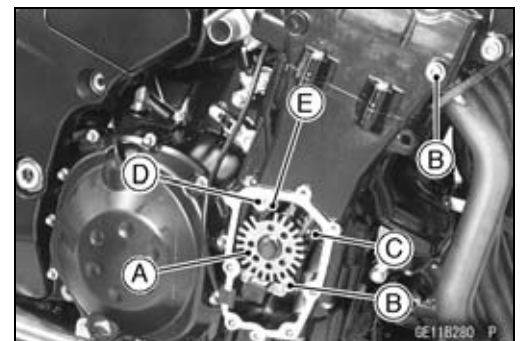

5-22 ENGINE TOP END

Camshaft, Camshaft Chain

- Remove the crankshaft sprocket [A].
- Pull out the camshaft chain [B] from downward.

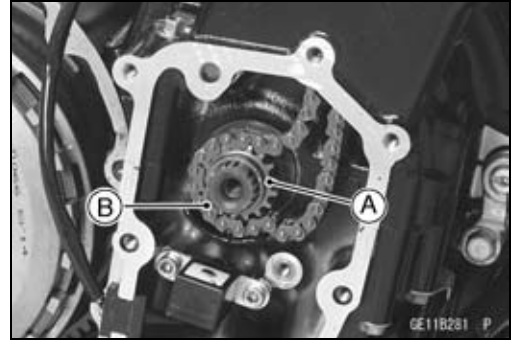

Camshaft Chain Installation

- Install the camshaft chain from head side.
- Install the crankshaft sprocket [A] on the crankshaft [B] with their teeth [C] aligned.
- Install the front camshaft chain guide, and tighten the bolts.

**Torque - Front Camshaft Chain Guide Bolt (Upper): 25 N·m
(2.5 kgf·m, 18 ft·lb)**

**Front Camshaft Chain Guide Bolt (Lower): 12 N·m
(1.2 kgf·m, 106 in·lb)**

- Install the removed parts (see appropriate chapters).

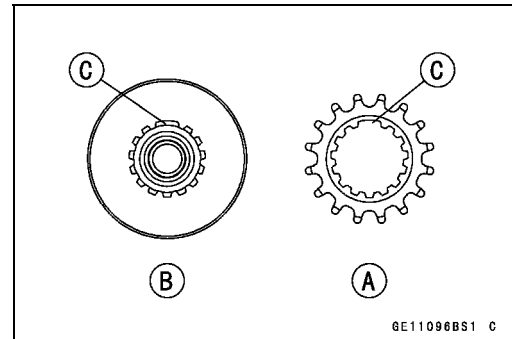

Cylinder Head

Cylinder Compression Measurement

NOTE

○ Use the battery which is fully charged.

- Warm up the engine thoroughly.
- Stop the engine.
- Remove:
 - Stick Coils (see Stick Coil (Ignition Coil together with Spark Plug Cap) Removal in the Electrical System chapter)
 - Spark Plugs (see Spark Plug Replacement in the Periodic Maintenance chapter)

Owner's Tool - Spark Plug Wrench: 92110-1132

- Attach the compression gauge [A] and adapter [B] firmly into the spark plug hole.
- Using the starter motor, turn the engine over with the throttle fully open until the compression gauge stops rising; the compression is the highest reading obtainable.

Special Tools - Compression Gauge, 20 kgf/cm²: 57001-221
Compression Gauge Adapter, M10 × 1.0: 57001-1601
L-Shape Hose: 57001-1606 [C]

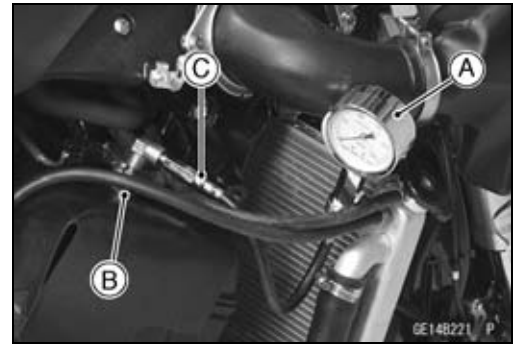

Cylinder Compression

Usable Range: 1 030 ~ 1 569 kPa (10.5 ~ 16.0 kgf/cm², 149 ~ 228 psi) @300 r/min (rpm)

- Repeat the measurement for the other cylinders.
- Install the spark plugs.

Torque - Spark Plugs: 13 N·m (1.3 kgf·m, 115 in·lb)

The following table should be consulted if the obtainable compression reading is not within the usable range.

Problem	Diagnosis	Remedy (Action)
Cylinder compression is higher than usable range	Carbon accumulation on piston and in combustion chamber possibly due to damaged valve stem oil seal and/or damaged piston oil rings (This may be indicated by white exhaust smoke).	Remove the carbon deposits and replace damaged parts if necessary.
	Incorrect cylinder head gasket thickness	Replace the gasket with a standard part.
Cylinder compression is lower than usable range	Gas leakage around cylinder head	Replace damaged check gasket and cylinder head warp.
	Bad condition of valve seating	Repair if necessary.
	Incorrect valve clearance	Adjust the valve clearance.
	Incorrect piston/cylinder clearance	Replace the piston and/or cylinder.
	Piston seizure	Inspect the cylinder and replace/repair the cylinder and/or piston as necessary.
	Bad condition of piston ring and/or piston ring grooves	Replace the piston and/or the piston rings.

5-24 ENGINE TOP END

Cylinder Head

Cylinder Head Removal

- Drain the coolant (see Coolant Change in the Periodic Maintenance chapter).
- Remove:
 - Fuel Tank (see Fuel Tank Removal in the Fuel System (DFI) chapter)
 - Throttle Body Assy (see Throttle Body Assy Removal in the Fuel System (DFI) chapter)
 - Exhaust Pipe (see Exhaust Pipe Removal)
 - Cylinder Head Cover (see Cylinder Head Cover Removal)
 - Camshafts (see Camshaft Removal)
 - Front Camshaft Chain Guide
 - Rear Camshaft Chain Guide
- Remove:
 - Front Engine Mounting Bolts [A]
 - Engine Bracket Mounting Bolts [B]
 - Engine Brackets [C]

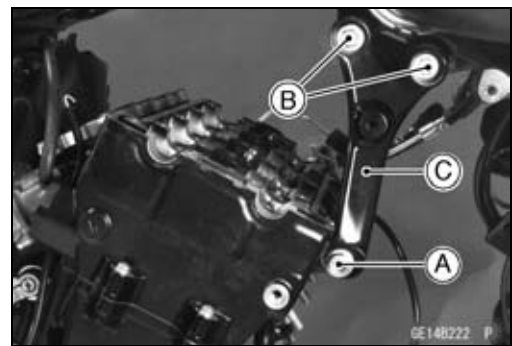

- Remove the M6 cylinder head bolts [B], and then the M11 cylinder head bolts [A].
- Take off the cylinder head.

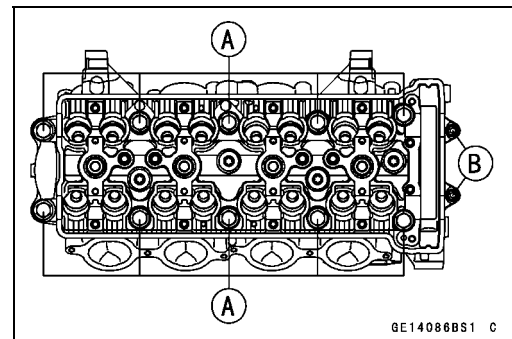

Cylinder Head Installation

NOTE

○The camshaft cap is machined with the cylinder head, so if a new cylinder head is installed, use the cap that is supplied with the new head.

- Install a new cylinder head gasket and dowel pins.
- Replace the cylinder head bolt washers with new ones.
- Apply molybdenum disulfide oil solution to both sides [A] of the cylinder head bolt washers [B] and the thread of head bolts [C].

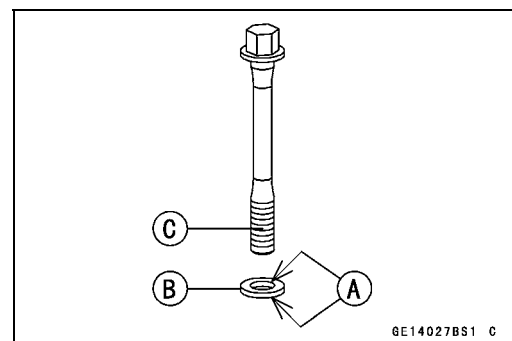

Cylinder Head

- Tighten the M11 cylinder head bolts following the tightening sequence [1 ~ 10].

Torque - Cylinder Head Bolts (M11):

First: 39 N·m (4.0 kgf·m, 29 ft·lb)

Final: 71 N·m (7.2 kgf·m, 52 ft·lb)

- Tighten the M6 cylinder head bolts [11 ~ 12].

Torque - Cylinder Head Bolts (M6): 12 N·m (1.2 kgf·m, 106 in·lb)

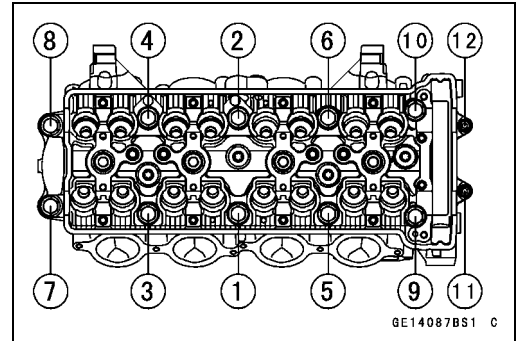

- Install:

Dowel Pin [A]

Rear Camshaft Chain Guide [B]

Front Camshaft Chain Guide [C]

O-ring [D]

Collar [E]

- Tighten:

Torque - Front Camshaft Chain Guide Bolt (Upper) [F]: 25 N·m (2.5 kgf·m, 18 ft·lb)

Front Camshaft Chain Guide Bolt (Lower) [G]: 12 N·m (1.2 kgf·m, 106 in·lb)

- Replace the following bolts with new bolts pre-coated with locking agent and torque them.

Engine Bracket Bolts

Front Engine Mounting Bolts

Subframe Bolts

Torque - Front Bracket Bolts: 25 N·m (2.5 kgf·m, 18 ft·lb)

Front Engine Mounting Bolts: 59 N·m (6.0 kgf·m, 44 ft·lb)

Subframe Bolts: 23 N·m (2.3 kgf·m, 17 ft·lb)

- Install the removed parts (see appropriate chapters).

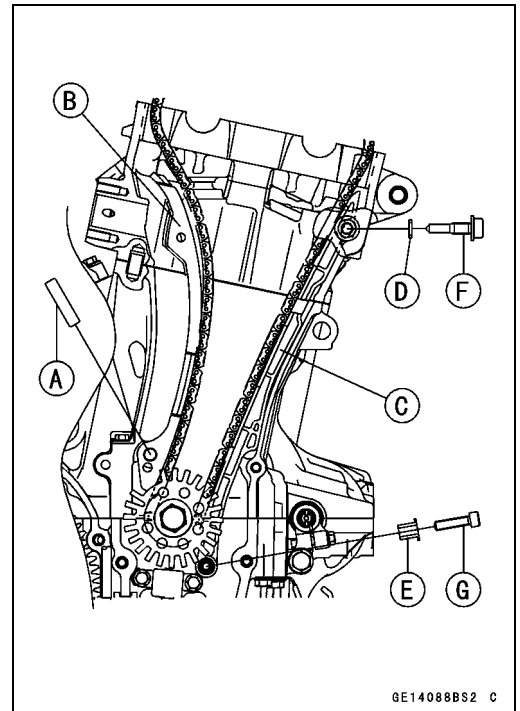

Cylinder Head Warp

- Clean the cylinder head.
- Lay a straightedge across the lower surface of the cylinder head at several positions.
- Use a thickness gauge [A] to measure the space between the straightedge [B] and the head.

Cylinder Head Warp

Standard: ---

Service Limit: 0.05 mm (0.002 in.)

- ★ If the cylinder head is warped more than the service limit, replace it.
- ★ If the cylinder head is warped less than the service limit, repair the head by rubbing the lower surface on emery paper secured to a surface plate (first No. 200, then No. 400).

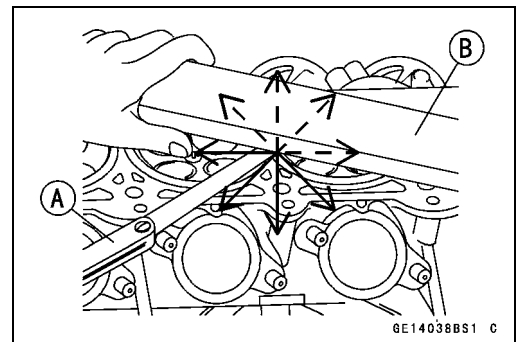

5-26 ENGINE TOP END

Valves

Valve Clearance Inspection

- Refer to the Valve Clearance Inspection in the Periodic Maintenance chapter.

Valve Removal

- Remove the cylinder head (see Cylinder Head Removal).
- Remove the valve lifter and shim.
- Mark and record the valve lifter and shim locations so they can be installed in their original positions.
- Using the valve spring compressor assembly, remove the valve.

Special Tools - Valve Spring Compressor Assembly: 57001-241 [A]

Adapter, ϕ 24: 57001-1586 [B]

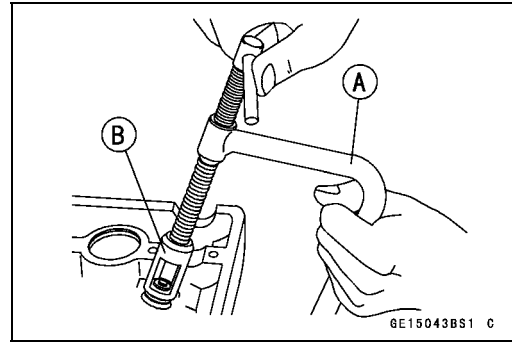

Valve Installation

CAUTION

Do not lap the exhaust valve to the exhaust valve seat, using the grinding compound. It will come off oxide film treated surface of the valve.

- Replace the oil seal with a new one.
- Apply a thin coat of molybdenum disulfide grease to the valve stem before valve installation.
- Install the springs so that the closed coil end faces downwards.

Valve Stem [A]
Oil Seal [B]
Spring Seat [C]
Closed Coil End [D]
Valve Spring [E]:
EX-White Paint
IN-Red Paint
Retainer [F]
Split Keepers [G]

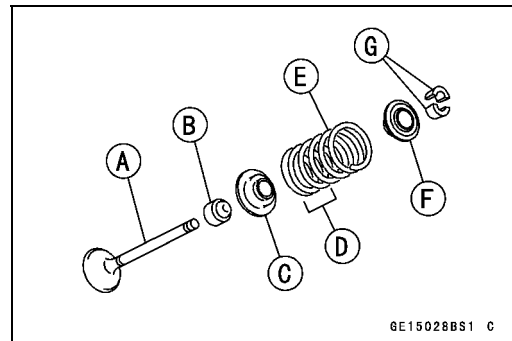

Valve Guide Removal

- Remove:
 - Valve (see Valve Removal)
 - Oil Seal
 - Spring Seat
- Heat the area around the valve guide to 120 ~ 150°C (248 ~ 302°F), and hammer lightly on the valve guide arbor [A] to remove the guide from the top of the head.

CAUTION

Do not heat the cylinder head with a torch. This will warp the cylinder head. Soak the cylinder head in oil and heat the oil.

Special Tool - Valve Guide Arbor, ϕ 5: 57001-1203

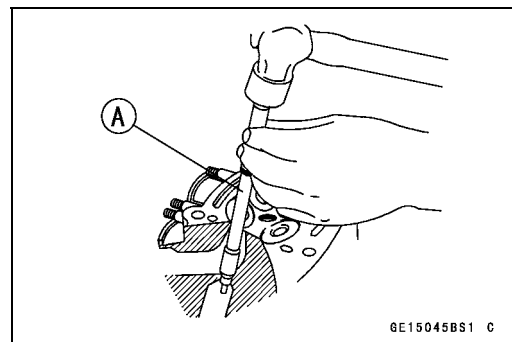

Valves

Valve Guide Installation

- Apply oil to the valve guide outer surface before installation.
- Heat the area around the valve guide hole to about 120 ~ 150°C (248 ~ 302°F).

CAUTION

Do not heat the cylinder head with a torch. This Will warp the cylinder head. Soak the cylinder head and heat the oil.

- Assemble the valve guide driver parts (Holder and attachment E).
- Insert the rod of the driver into the valve guide bore and hammer the end of the driver until it bottoms.

Valve Guide Driver Attachment E [A]

Valve Guide Driver (Holder) [B]

Valve Guide [C]

Cylinder Head [D]

Valve Guide Installed Height = 13 mm [E]

Special Tools - Valve Guide Driver: 57001-1564

Valve Guide Driver Attachment, E: 57001-1677

- Ream the valve guide with valve guide reamer [A], even if the old guide is reused.

Special Tool - Valve Guide Reamer, ϕ 5: 57001-1204

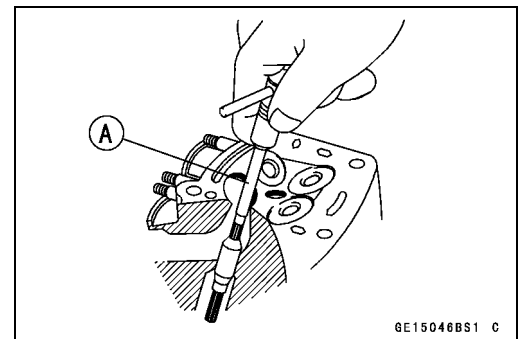
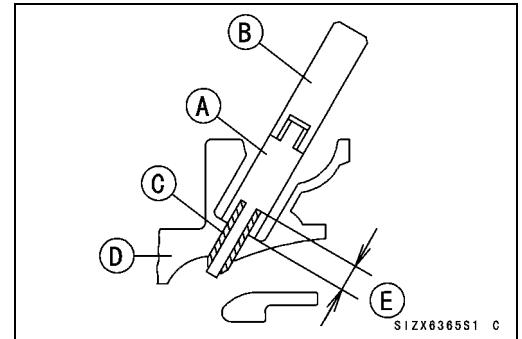

5-28 ENGINE TOP END

Valves

Valve-to-Guide Clearance Measurement (Wobble Method)

If a small bore gauge is not available, inspect the valve guide wear by measuring the valve to valve guide clearance with the wobble method as indicated below.

- Insert a new valve [A] into the guide [B] and set a dial gauge against the stem perpendicular to it as close as possible to the cylinder head mating surface.
- Move the stem back and forth [C] to measure valve/valve guide clearance.
- Repeat the measurement in a direction at a right angle to the first.
- ★ If the reading exceeds the service limit, replace the guide.

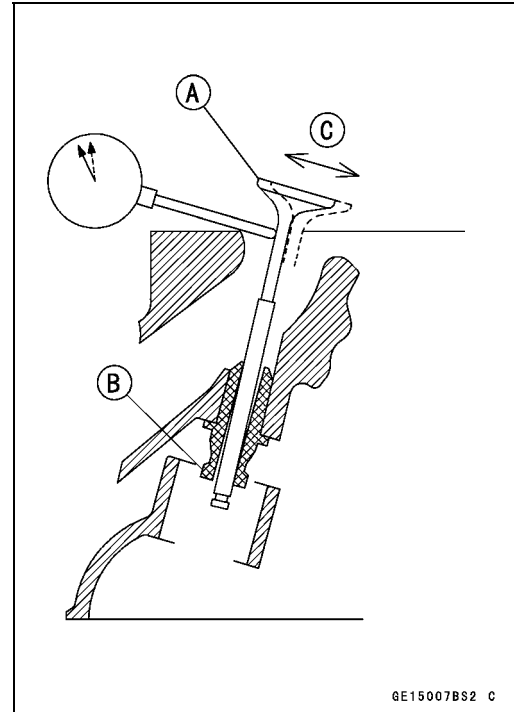

NOTE

- The reading is not actual valve/valve guide clearance because the measuring point is above the guide.

Valve/Valve Guide Clearance (Wobble Method)

Standard:

Exhaust	0.10 ~ 0.18 mm (0.0039 ~ 0.0071 in.)
Inlet	0.03 ~ 0.12 mm (0.0012 ~ 0.0047 in.)

Service Limit:

Exhaust	0.39 mm (0.015 in.)
Inlet	0.33 mm (0.013 in.)

Valves

Valve Seat Inspection

- Remove the valve (see Valve Removal).
- Check the valve seating surface [A] between the valve [B] and valve seat [C].
- Measure the outside diameter [D] of the seating pattern on the valve seat.
- ★ If the outside diameter is too large or too small, repair the seat (see Seat Repair).

Valve Seating Surface Outside Diameter

Standard:

Exhaust 27.6 ~ 27.8 mm (1.087 ~ 1.094 in.)

Inlet 32.6 ~ 32.8 mm (1.283 ~ 1.291 in.)

- Measure the seat width [E] of the portion where there is no build-up carbon (white portion) of the valve seat with a vernier caliper.

Good [F]

- ★ If the width is too wide [G], too narrow [H] or uneven [J], repair the seat (see Valve Seat Repair).

Valve Seating Surface Width

Standard:

Exhaust 0.8 ~ 1.2 mm (0.031 ~ 0.047 in.)

Inlet 0.5 ~ 1.0 mm (0.020 ~ 0.039 in.)

Valve Seat Repair

- Repair the valve seat with the valve seat cutters [A].

Special Tools - Valve Seat Cutter Holder, $\phi 5$: 57001-1208 [B]

Valve Seat Cutter Holder Bar: 57001-1128 [C]

For Exhaust Valve Seat

Valve Seat Cutter, 45° - $\phi 30$: 57001-1187

Valve Seat Cutter, 32° - $\phi 30$: 57001-1120

Valve Seat Cutter, 60° - $\phi 30$: 57001-1123

For Inlet Valve Seat

Valve Seat Cutter, 45° - $\phi 35$: 57001-1116

Valve Seat Cutter, 32° - $\phi 35$: 57001-1121

Valve Seat Cutter, 60° - $\phi 33$: 57001-1334

- ★ If the manufacturer's instructions are not available, use the following procedure.

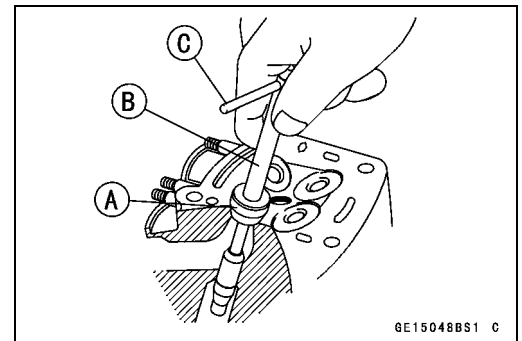
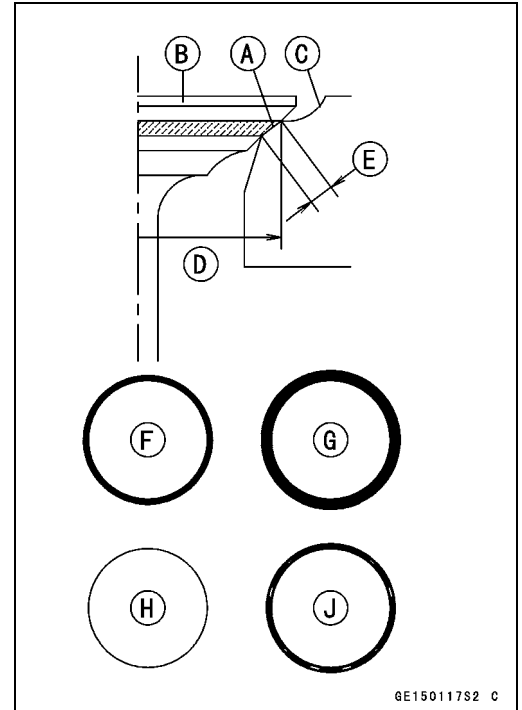

5-30 ENGINE TOP END

Valves

Seat Cutter Operation Care

1. This valve seat cutter is developed to grind the valve for repair. Therefore the cutter must not be used for other purposes than seat repair.
2. Do not drop or shock the valve seat cutter, or the diamond particles may fall off.
3. Do not fail to apply engine oil to the valve seat cutter before grinding the seat surface. Also wash off ground particles sticking to the cutter with washing oil.

NOTE

○Do not use a wire brush to remove the metal particles from the cutter. It will take off the diamond particles.

4. Setting the valve seat cutter holder in position, operate the cutter in one hand. Do not apply too much force to the diamond portion.

NOTE

○Prior to grinding, apply engine oil to the cutter and during the operation, wash off any ground particles sticking to the cutter with washing oil.

5. After use, wash it with washing oil and apply thin layer of engine oil before storing.

Marks Stamped on the Cutter

The marks stamped on the back of the cutter [A] represent the following.

- 60° Cutter angle [B]
φ37.5 Outer diameter of cutter [C]

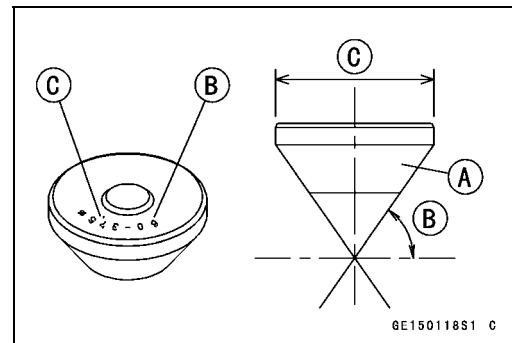

Operating Procedures

- Clean the seat area carefully.
- Coat the seat with machinist's dye.
- Fit a 45° cutter into the holder and slide it into the valve guide.
- Press down lightly on the handle and turn it right or left. Grind the seating surface only until it is smooth.

CAUTION

Do not grind the seat too much. Overgrinding will reduce valve clearance by sinking the valve into the head. If the valve sinks too far into the head, it will be impossible to adjust the clearance, and the cylinder head must be replaced.

Valves

- Measure the outside diameter of the seating surface with a vernier caliper.
- ★ If the outside diameter of the seating surface is too small, repeat the 45° grind until the diameter is within the specified range.
 - Widened Width [A] of engagement by machining with 45° cutter
 - Ground Volume [B] by 32° cutter
 - 32° [C]
 - Correct Width [D]
 - Ground Volume [E] by 60° cutter
 - 60° [F]

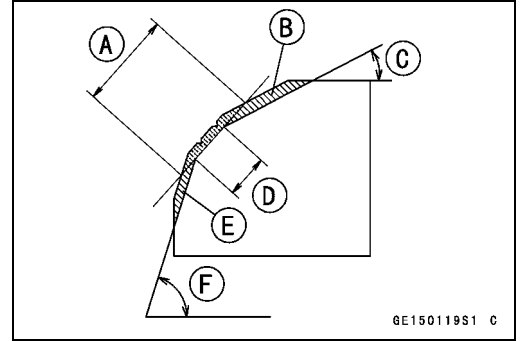

- Measure the outside diameter of the seating surface with a vernier caliper.
- ★ If the outside diameter of the seating surface is too small, repeat the 45° grind [A] until the diameter is within the specified range.
 - Original Seating Surface [B]

NOTE

- Remove all pittings of flaws from 45° ground surface.
- After grinding with 45° cutter, apply thin coat of machinist's dye to seating surface. This makes seating surface distinct and 32° and 60° grinding operation easier.
- When the valve guide is replaced, be sure to grind with 45° cutter for centering and good contact.

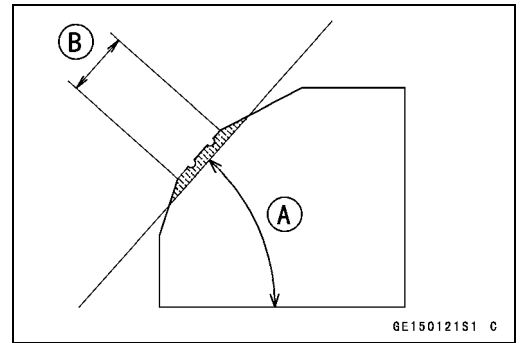

- ★ If the outside diameter [A] of the seating surface is too large, make the 32° grind described below.
- ★ If the outside diameter of the seating surface is within the specified range, measure the seat width as described below.
- Grind the seat at a 32° angle [B] until the seat O.D. is within the specified range.
 - To make the 32° grind, fit a 32° cutter into the holder, and slide it into the valve guide.
 - Turn the holder one turn at a time while pressing down very lightly. Check the seat after each turn.

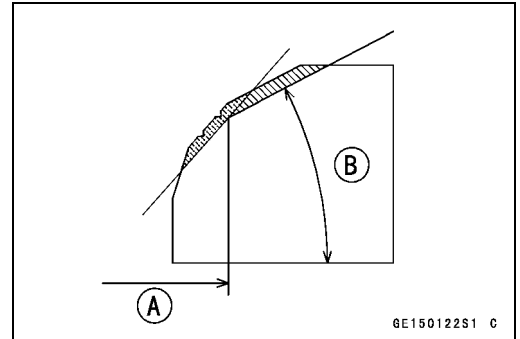

CAUTION

The 32° cutter removes material very quickly. Check the seat outside diameter frequently to prevent overgrinding.

- After making the 32° grind, return to the seat O.D. measurement step above.
- To measure the seat width, use a vernier caliper to measure the width of the 45° angle portion of the seat at several places around the seat.
- ★ If the seat width is too narrow, repeat the 45° grind until the seat is slightly too wide, and then return to the seat O.D. measurement step above.

5-32 ENGINE TOP END

Valves

- ★ If the seat width is too wide, make the 60° [A] grind described below.
- ★ If the seat width is within the specified range, lap the valve to the seat as described below.
- Grind the seat at a 60° angle until the seat width is within the specified range.
- To make the 60° grind, fit 60° cutter into the holder, and slide it into the valve guide.
- Turn the holder, while pressing down lightly.
- After making the 60° grind, return to the seat width measurement step above.
Correct Width [B]

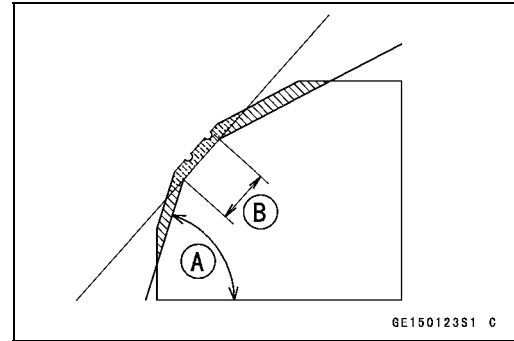

CAUTION

Do not lap the exhaust valve to the exhaust valve seat, using the grinding compound. It will come off oxide film treated surface of the valve.

- Lap the inlet valve to the inlet valve seat, once the seat width and O.D. are within the ranges specified above.
- Put a little coarse grinding compound on the face of the valve in a number of places around the valve head.
- Spin the valve against the seat until the grinding compound produces a smooth, matched surface on both the seat and the valve.
- Repeat the process with a fine grinding compound.
Lapper [A]
Valve Seat [B]
Valve [C]
- The seating area should be marked about in the middle of the valve face.
- ★ If the seat area is not in the right place on the valve, check to be sure the valve is the correct part. If it is, it may have been refaced too much; replace it.
- Be sure to remove all grinding compound before assembly.
- When the engine is assembled, be sure to adjust the valve clearance (see Valve Clearance Inspection in the Periodic Maintenance chapter).

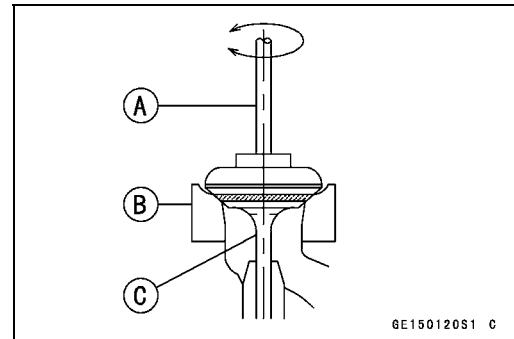

Valves

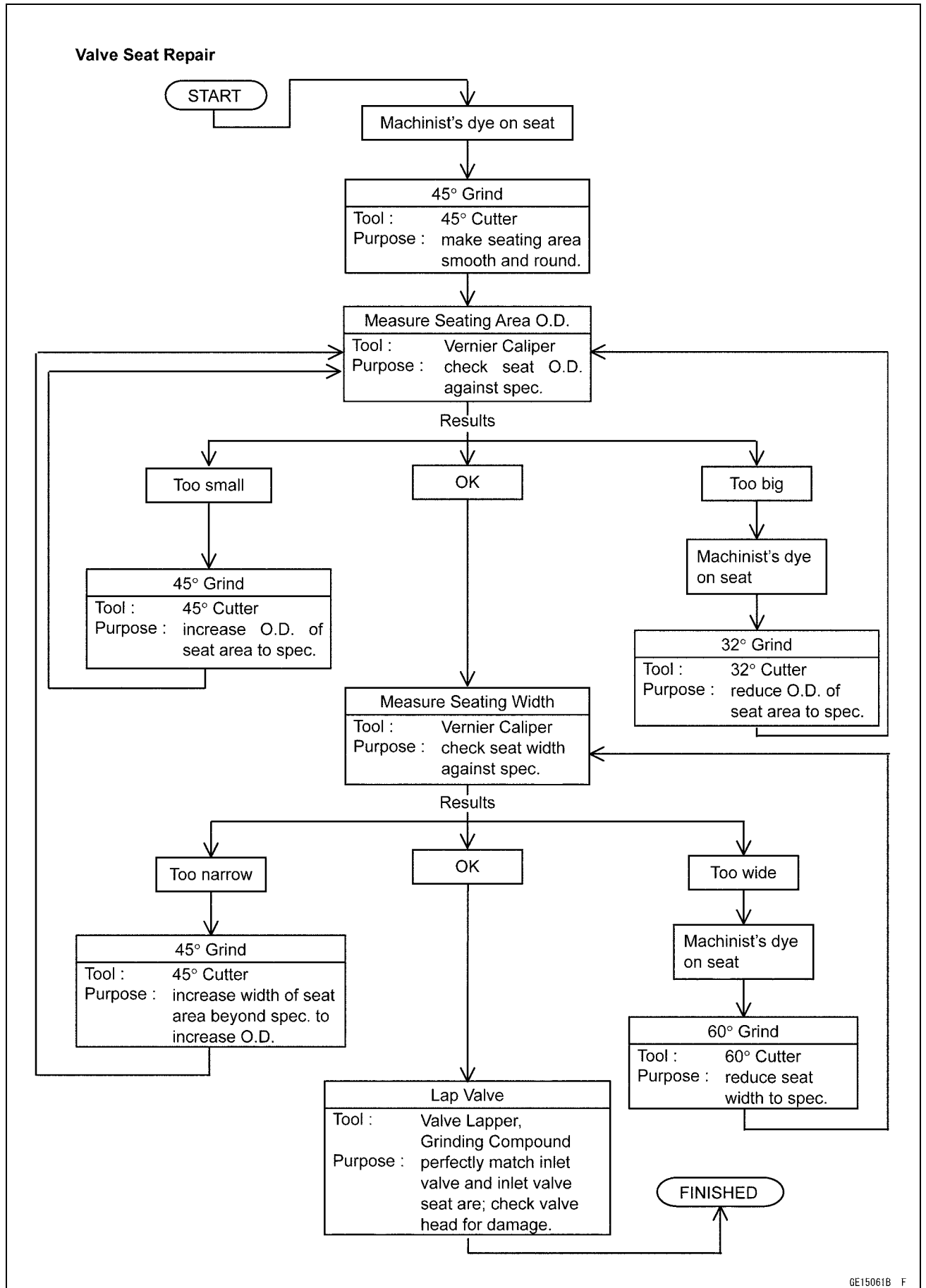

5-34 ENGINE TOP END

Throttle Body Holder

Throttle Body Holder Installation

- Be sure to install the O-rings [A].
- Install the clamps [B] as shown.
- Tighten the holder bolts following the tightening sequence [1 ~ 3].

Torque - Throttle Body Holder Bolts [C]: 9.8 N·m (1.0 kgf·m, 87 in·lb)

Throttle Body Assy Holder Clamp Bolts [D]: 2.0 N·m (0.20 kgf·m, 18 in·lb)

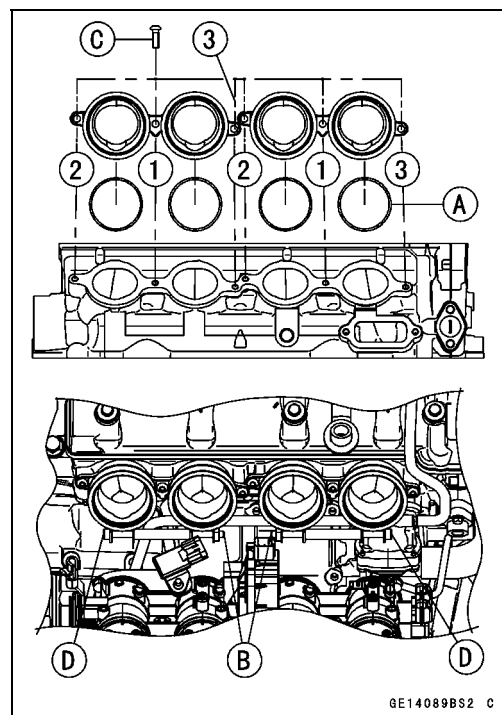

Muffler

⚠ WARNING

To avoid a serious burn, do not remove the muffler when the engine is still hot. Wait until the muffler cool down.

Muffler Body Removal/Installation

- Remove:
 - Lower Fairings (see Lower Fairing Removal in the Frame chapter)
 - Rear Fairing (see Rear Fairing Removal in the Frame chapter)
 - Muffler Clamp Bolts [A]
 - Muffler Mounting Bolts and Nuts [B]
- Pull the muffler body [C] backward.

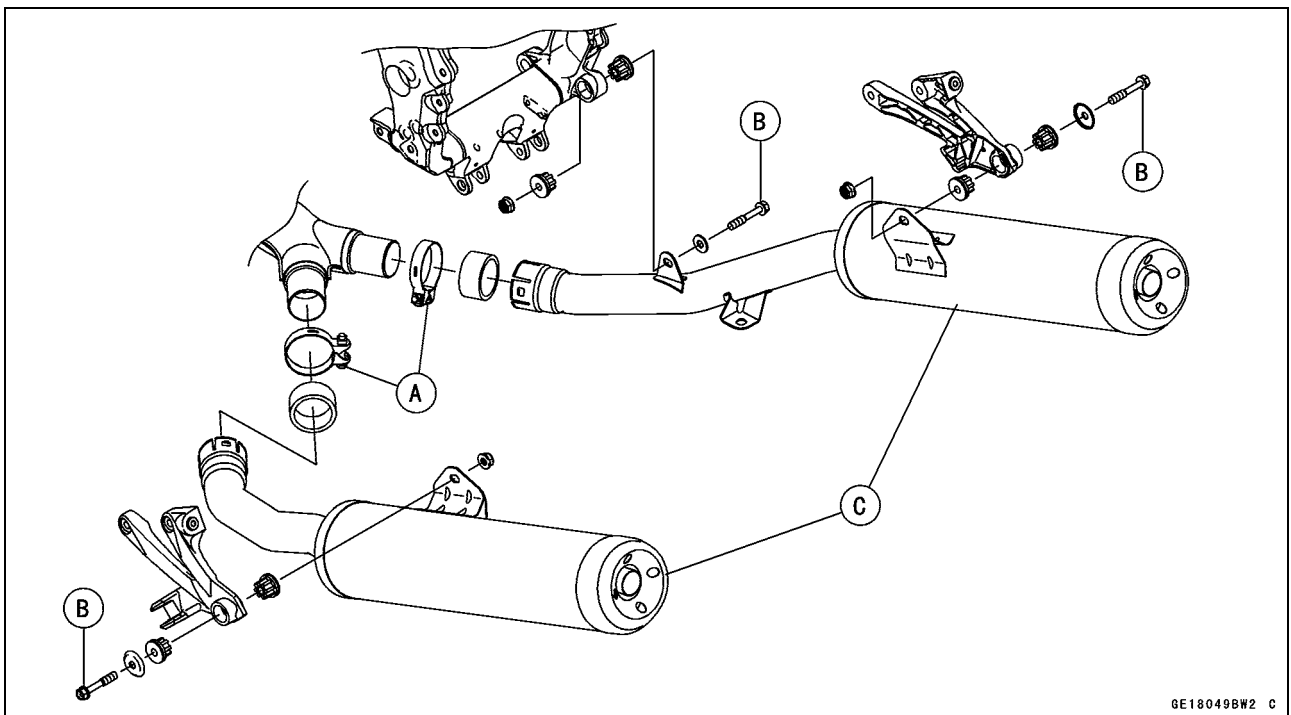

GE18049BW2 C

- Replace the muffler gaskets [A] with new ones.
- Install the gaskets until they are bottomed [B].
- Install the gaskets so that their chamfer sides [C] face the front.

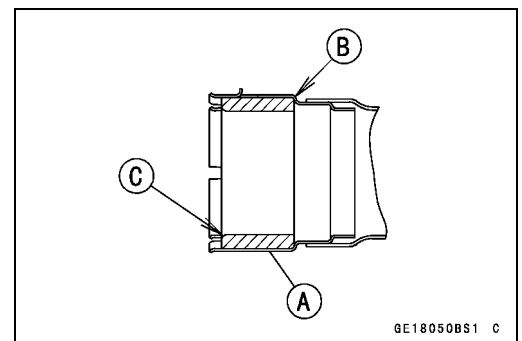

GE18050BS1 C

5-36 ENGINE TOP END

Muffler

- Align [A] the projections on the muffler bodies with the hoses on the muffler clamps.

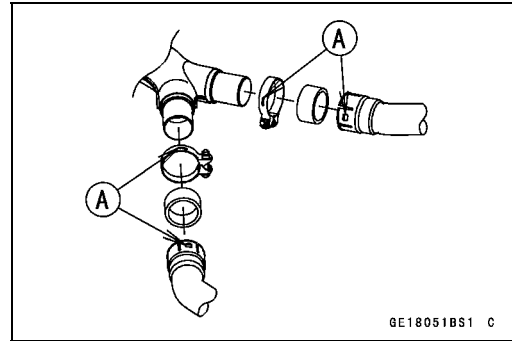

- Tighten:
Torque - Muffler Body Mounting Bolts: 34 N·m (3.5 kgf·m, 25 ft·lb)

Exhaust Pipe Removal

- Remove:
Radiator (see Radiator Removal in the Cooling System chapter)
Right and Left Muffler Body (see Muffler Body Removal/Installation)
- Remove the exhaust pipe manifold holder nuts [A].
- Remove the exhaust pipe manifold [B].



Exhaust Pipe Installation

- Replace the exhaust pipe gaskets [A], muffler gasket with new ones and install them.
- Install the muffler gasket until it is bottomed so that the chamfer side faces front (see Muffler Body Removal/Installation).
- Tighten:
Torque - Muffler Body Mounting Bolts: 34 N·m (3.5 kgf·m, 25 ft·lb)

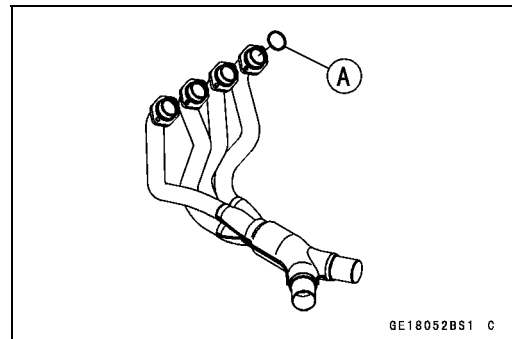

Clutch

Table of Contents

Exploded View	6-2
Specifications	6-4
Special Tools and Sealant	6-5
Clutch Master Cylinder	6-6
Clutch Lever Adjustment.....	6-6
Clutch Master Cylinder Removal	6-6
Clutch Master Cylinder Installation	6-6
Clutch Master Cylinder Disassembly	6-7
Clutch Master Cylinder Assembly	6-7
Clutch Master Cylinder Inspection	6-7
Clutch Slave Cylinder	6-8
Clutch Slave Cylinder Removal	6-8
Clutch Slave Cylinder Installation	6-9
Clutch Slave Cylinder Disassembly	6-9
Clutch Slave Cylinder Assembly	6-9
Clutch Fluid.....	6-10
Clutch Fluid Level Inspection	6-10
Clutch Fluid Change	6-10
Bleeding the Clutch Line	6-10
Clutch Hose Removal/Installation	6-11
Clutch Hose and Connection Inspection.....	6-11
Clutch Cover.....	6-12
Clutch Cover Removal.....	6-12
Clutch Cover Installation	6-12
Clutch	6-13
Clutch Removal.....	6-13
Clutch Installation.....	6-14
Clutch Plate Assembly Inspection.....	6-16
Clutch Plate Assembly Adjustment	6-16
Clutch Plate, Wear, Damage Inspection	6-17
Clutch Plate Warp Inspection.....	6-17
Clutch Spring Free Length Measurement.....	6-17

6-2 CLUTCH

Exploded View

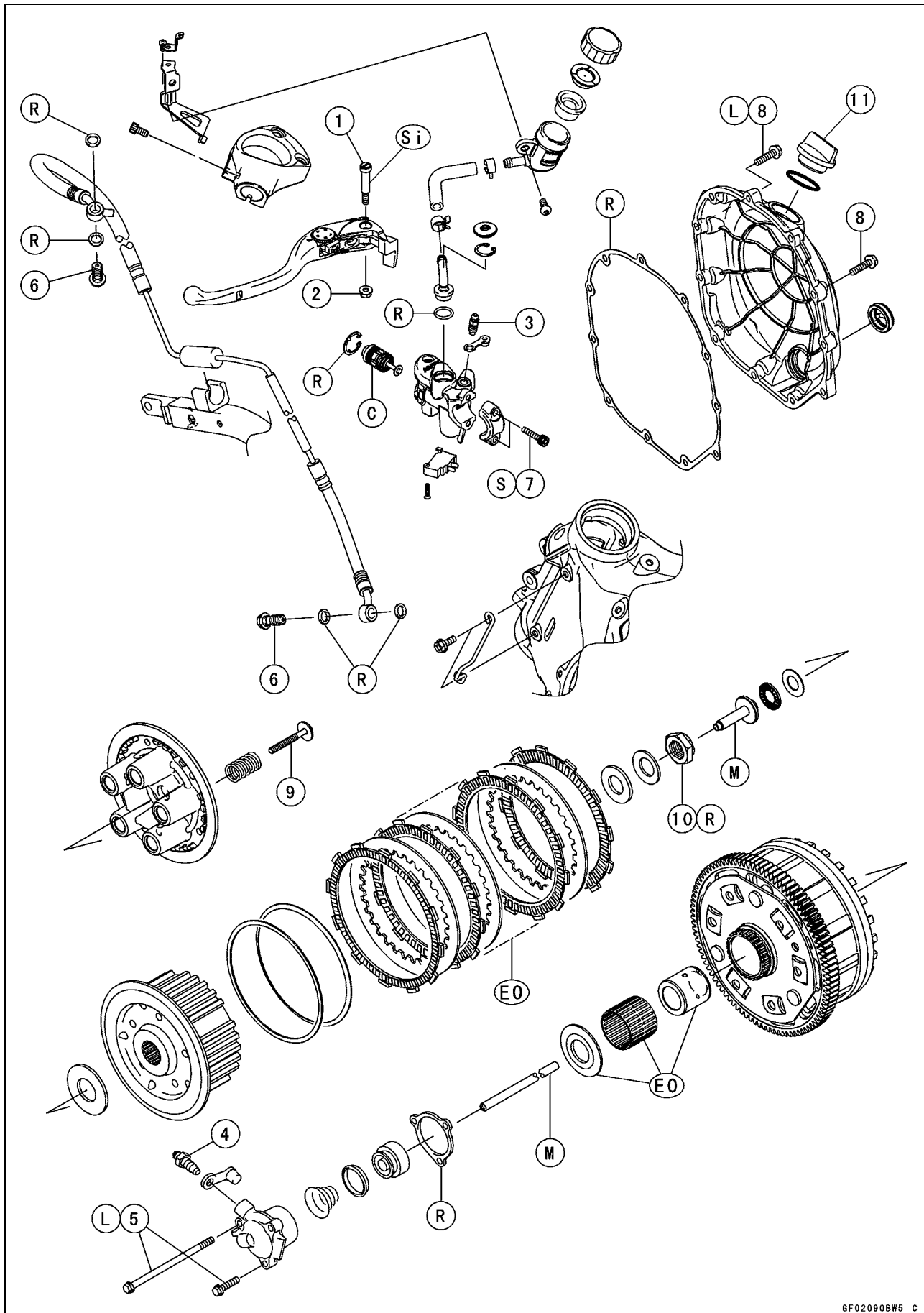

Exploded View

No.	Fastener	Torque			Remarks
		N·m	kgf·m	ft·lb	
1	Clutch Lever Pivot Bolt	1.0	0.10	8.9 in·lb	
2	Clutch Lever Pivot Bolt Locknut	5.9	0.60	52 in·lb	
3	Clutch Master Cylinder Bleed Valve	7.8	0.80	69 in·lb	
4	Clutch Slave Cylinder Bleed Valve	7.8	0.80	69 in·lb	
5	Clutch Slave Cylinder Bolts	–	–	–	L
6	Clutch Hose Banjo Bolt	25	2.5	18	
7	Clutch Master Cylinder Clamp Bolts	8.8	0.90	78 in·lb	S
8	Clutch Cover Bolts	9.8	1.0	87 in·lb	L (1)
9	Clutch Spring Bolts	8.8	0.9	78 in·lb	
10	Clutch Hub Nut	135	14	100	R
11	Oil Filler Cap	–	–	–	Hand-tighten

C: Apply clutch fluid.

EO: Apply engine oil.

L: Apply a non-permanent locking agent.

M: Apply molybdenum disulfide grease.

R: Replacement Parts

S: Follow the specific tightening sequence.

Si: Apply silicone grease.

6-4 CLUTCH

Specifications

Item	Standard	Service Limit
Clutch Fluid: Grade	DOT4	---
Clutch Lever: Clutch Lever Position Clutch Lever Free Play	5-way adjustable (to suit rider) Non-adjustable	--- --- ---
Clutch: Friction Plate Thickness (13088-0030, 13088-0031)	2.92 ~ 3.08 mm (0.115 ~ 0.121 in.)	2.7 mm (0.106 in.)
Friction Plate Thickness (13088-0032)	3.72 ~ 3.88 mm (0.146 ~ 0.153 in.)	3.5 mm (0.138 in.)
Friction and Steel Plate Warp	0.15 mm (0.0059 in.) or less	0.3 mm (0.012 in.)
Friction Plate Warp (only 13088-0030)	0.2 mm (0.008 in.) or less	0.3 mm (0.012 in.)
Clutch Spring Free Length	65.0 mm (2.56 in.)	62.0 mm (2.44 in.)

Special Tools and Sealant

Inside Circlip Pliers:
57001-143

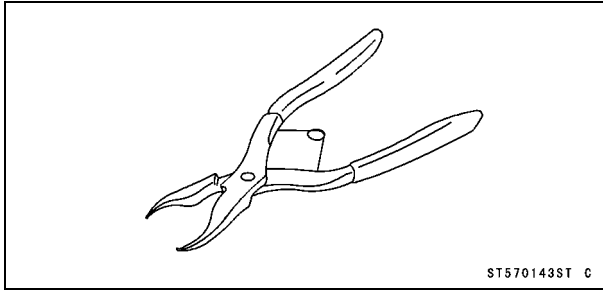

Clutch Gear Setting Screw:
57001-1671

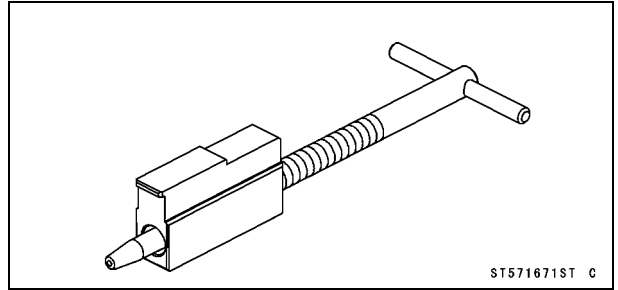

Clutch Holder:
57001-1243

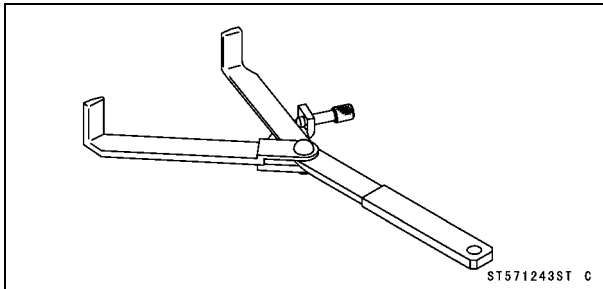

Kawasaki Bond (Silicone Sealant):
92104-0004

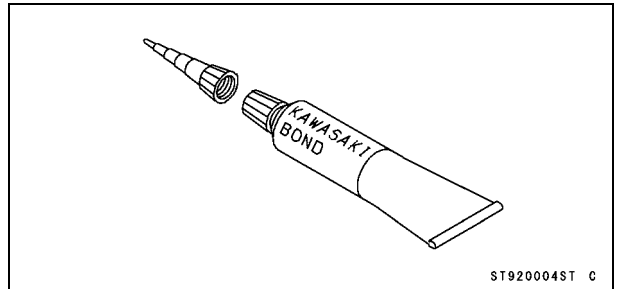

6-6 CLUTCH

Clutch Master Cylinder

Clutch Lever Adjustment

- The adjuster has 5 positions so that the clutch lever position can be adjusted to suit the operator's hand.
- Push the lever forward and turn the adjuster [A] to align the number with the triangular mark [B] on the lever holder (front view).
- The distance from the grip to the lever is minimum at Number 5 and maximum at Number 1.

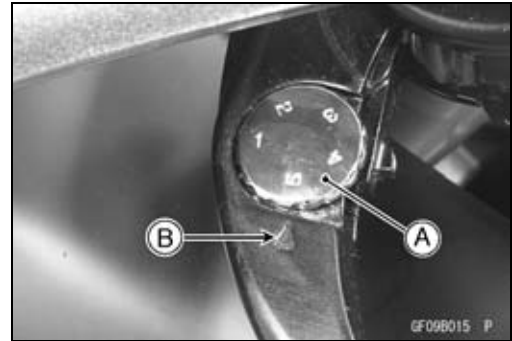

Clutch Master Cylinder Removal

- Disconnect the starter lockout switch connector [A] (rear view).
- Drain the clutch fluid from the reservoir (see Clutch Fluid Change in the Periodic Maintenance chapter).



- Remove:
 - Bracket Bolt [A]
 - Clutch Reservoir Bolt [B]
- Remove the banjo bolt [C] to disconnect the clutch hose from the master cylinder (rear view).
- Unscrew the clamp bolts [D], and take off the master cylinder as an assembly with the clutch reservoir, clutch lever, and starter lockout switch installed.

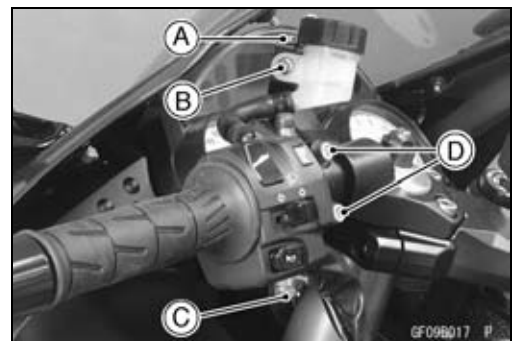

CAUTION

Clutch fluid quickly ruins painted surface; any spilled fluid should be completely washed away immediately.

Clutch Master Cylinder Installation

- Align the punch mark [A] on the handlebar with the mating surface [B] of the master cylinder clamp (left view).
Front [C]

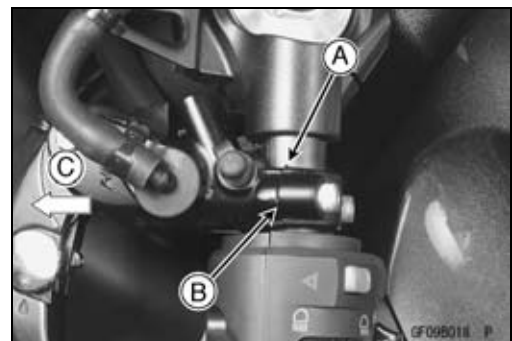

Clutch Master Cylinder

- Install the master cylinder clamp with the triangular mark [A] up.
- Tighten the upper clamp bolt [B] first, and then the lower clamp bolt [C]. There will be a gap at the lower part of the clamp after tightening.

Torque - Clutch Master Cylinder Clamp Bolts: 8.8 N·m (0.90 kgf·m, 78 in·lb)

- Use a new flat washer on each side of the clutch hose fitting.

Torque - Clutch Hose Banjo Bolt: 25 N·m (2.5 kgf·m, 18 ft·lb)

- Replenish the clutch fluid into the reservoir and bleed the clutch line (See Bleeding the Clutch Line in this chapter).
- Check that the clutch line has proper fluid pressure and no fluid leakage.

Clutch Master Cylinder Disassembly

- Refer to the Clutch Master Cylinder Cap and Dust Seal Replacement in the Periodic Maintenance chapter.

Clutch Master Cylinder Assembly

- Refer to the Clutch Master Cylinder Cap and Dust Seal Replacement in the Periodic Maintenance chapter.

Clutch Master Cylinder Inspection

- Disassemble the clutch master cylinder (see Clutch Master Cylinder Cap and Dust Seal Replacement in the Periodic Maintenance chapter).

Special Tool - Inside Circlip Pliers: 57001-143

- Check that there are no scratches, rust or pitting on the inside of the master cylinder [A] and on the outside of the piston [B].
- ★ If the master cylinder or piston shows any damage, replace them.
- Inspect the primary cup [C] and secondary cup [D].
- ★ If a cup is worn, damaged, softened (rotted), or swollen, the piston assembly should be replaced to renew the cup.
- If fluid leakage is noted at the clutch lever, the piston assembly should be replaced to renew the cup.
- Check the dust cover [E] for damage.
- If it is damaged, replace the piston assembly.
- Check that the relief [F] and supply [G] ports are not plugged.
- ★ If the small relief port becomes plugged, the clutch will drag. Blow the ports clean with compressed air.
- Check the piston return spring [H] for any damage.
- ★ If the spring is damaged, replace it.

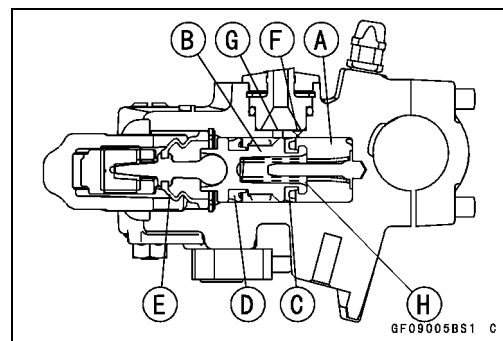
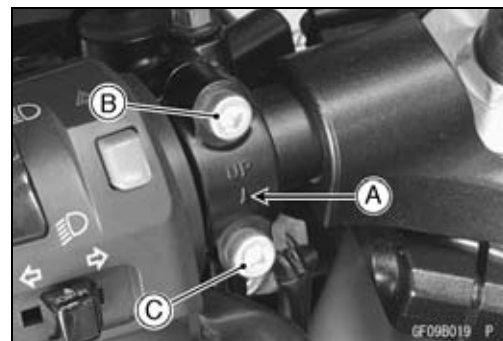

6-8 CLUTCH

Clutch Slave Cylinder

Clutch Slave Cylinder Removal

- Remove:
 - Left Lower Fairing (see Lower Fairing Removal Frame chapter)
 - Left Middle Fairing (see Middle Fairing Removal in the Frame chapter)
 - Banjo Bolt [A]
 - Clutch Slave Cylinder Bolts [B]
 - Slave Cylinder [C]

CAUTION

Immediately wash away any clutch fluid that spills. It may damage painted surfaces.

- Pull off the clutch pipe [A] by prying the dampers [B] out of the grooves of the frame. This prevents the pipe from distorting.

- Perform the following if the clutch slave cylinder is to be removed but not disassembled.

CAUTION

If the clutch slave cylinder is removed and left alone, the piston will be pushed out by spring force and the clutch fluid will drain out.

- Remove the clutch slave cylinder from the engine with the pipe installed. Push [A] the piston into the cylinder as far as it will go.
- Apply the clutch lever [A] slowly and hold it with a band [B].

NOTE

○ *Holding the clutch lever keeps the piston from coming out.*

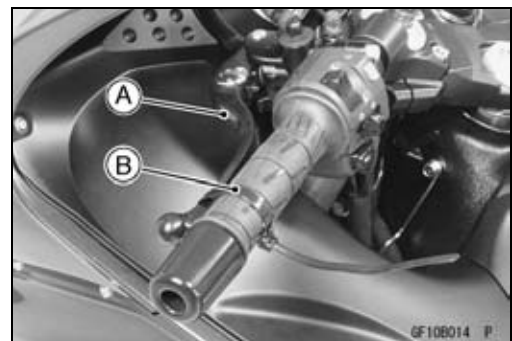
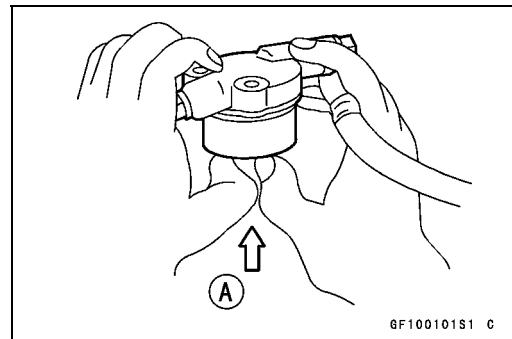
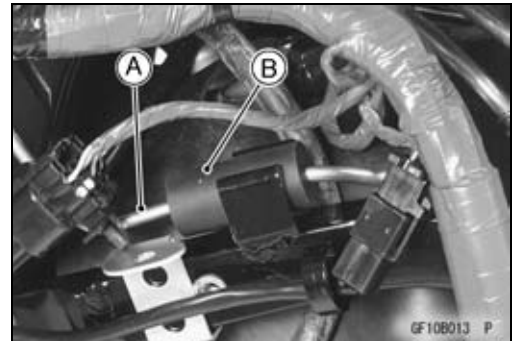
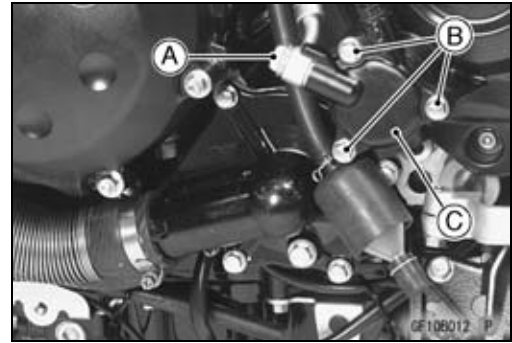

Clutch Slave Cylinder

Clutch Slave Cylinder Installation

- Apply molybdenum disulfide grease to either end [A] of the push rod, and install the push rod so that the greased end faces in.
- Replace the spacer [B] of the clutch slave cylinder with a new one.
- Install the spacer so that the stepped side [C] faces outward.

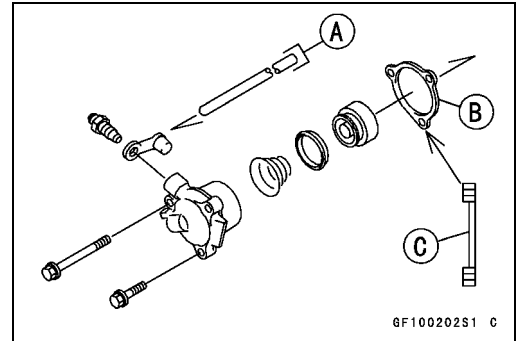

- Apply a non-permanent locking agent to the threads of the slave cylinder bolts [A].
- Finger tighten all the clutch slave cylinder bolts.
- Remove the band from the clutch lever and release the clutch lever.
- Tighten the slave cylinder bolts.
- Replace the washer on each side of the clutch hose fitting with new one.
- Tighten the banjo bolt [B] to the specified torque.

Torque - Clutch Pipe Banjo Bolt: 25 N·m (2.5 kgf·m, 18 ft·lb)

- Check the fluid level in the master cylinder reservoir, and bleed the air in the clutch line.
- Check the clutch operation.
- Install the removed parts.
 - Coolant Reserve Tank
 - Left Lower Fairing (see Lower Fairing Installation in the Frame chapter)

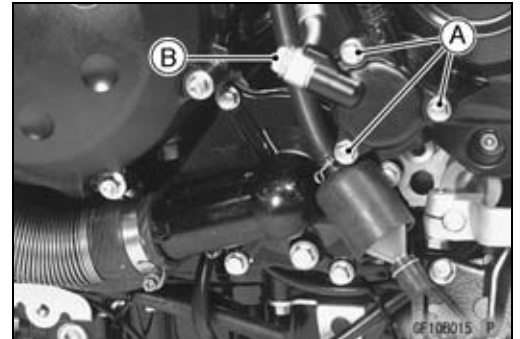

Clutch Slave Cylinder Disassembly

- Refer to Rubber Parts of Clutch Master Cylinder/Slave Cylinder Replacement in the Periodic Maintenance chapter.

Clutch Slave Cylinder Assembly

- Refer to Rubber Parts of Clutch Master Cylinder/Slave Cylinder Replacement in the Periodic Maintenance chapter.

6-10 CLUTCH

Clutch Fluid

Clutch Fluid Level Inspection

- Refer to the Clutch Fluid Level Inspection in the Periodic Maintenance chapter.

Clutch Fluid Change

- Refer to the Clutch Fluid Change in the Periodic Maintenance chapter.

Bleeding the Clutch Line

⚠ WARNING

Be sure to bleed the air from the clutch line whenever clutch lever action feels soft or spongy after the clutch fluid is changed, or whenever a clutch line fitting has been loosened for any reason.

CAUTION

Clutch fluid quickly ruins painted or plastic surfaces; any spilled fluid should be completely wiped up immediately with wet cloth.

- Remove:
 - Screw [A]
 - Clamp [B]
 - Clutch Reservoir Cap [C]
 - Diaphragm Plate
 - Diaphragm
- Fill the reservoir with fresh clutch fluid to the upper level line in the reservoir.

NOTE

○ Tap the clutch hose lightly going from the lower end to upper end and bleed the air off the reservoir.

- With the reservoir cap off, slowly pump the clutch lever several times until no air bubbles can be seen rising up through the fluid from the holes at the bottom of the reservoir.
- Bleed the air completely from the master cylinder by this operation.
- Remove the rubber cap from the bleed valve on the master cylinder.
- Attach a clear plastic hose [A] to the bleed valve, and run the other end of the hose into a container.

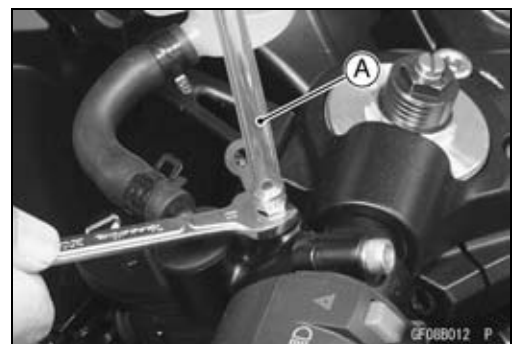
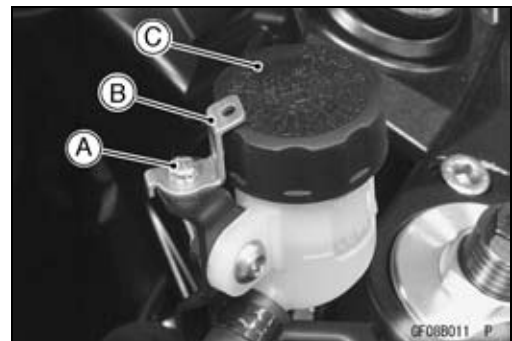

Clutch Fluid

- Bleed the clutch line and the master cylinder.
- Repeat this operation until no more air can be seen coming out into the plastic hose.
 1. Pump the clutch lever until it becomes hard, and apply the clutch lever and hold it [C].
 2. Quickly open and close [B] the bleed valve while holding the clutch lever applied.
 3. Release the clutch lever [A].

NOTE

- *The fluid level must be checked often during the bleeding operation and replenished with fresh clutch fluid as necessary. If the fluid in the reservoir runs completely out any time during bleeding, the bleeding operation must be done over again from the beginning since air will have entered the line.*

- Remove the clear plastic hose.
- Tighten the bleed valve, and install the rubber cap.

Torque - Clutch Master Cylinder Bleed Valve: 7.8 N·m (0.80 kgf·m, 69 in·lb)

- Remove the left lower fairing (see Lower Fairing Removal in the Frame chapter).
- Remove the rubber cap from the bleed valve.
- Attach a clear plastic hose [A] to the bleed valve on the clutch slave cylinder, and run the other end of the hose into a container.
- Bleed the clutch line as follows:
 - Repeat this operation until no more air can be seen coming out into the plastic hose.
 1. Pump the clutch lever a few times until it becomes hard and then hold it applied [D].
 2. Quickly open and close [C] the bleed valve.
 3. Release the clutch lever [B].

NOTE

- *Check the fluid level in the reservoir often, replenishing it as necessary.*
- *If the fluid in the reservoir runs completely out any time during bleeding, the bleeding operation must be done over again from the beginning since air will have entered the line.*

⚠ WARNING

Do not mix different grades and brands of fluid.

- Remove the clear plastic hose.

Torque - Clutch Slave Cylinder Bleed Valve: 7.8 N·m (0.80 kgf·m, 69 in·lb)

Clutch Hose Removal/Installation

- Refer to the Clutch Hose and Pipe Replacement in the Periodic Maintenance chapter.

Clutch Hose and Connection Inspection

- Refer to the Clutch Hose Damage and Installation Connection Inspection in the Periodic Maintenance chapter.

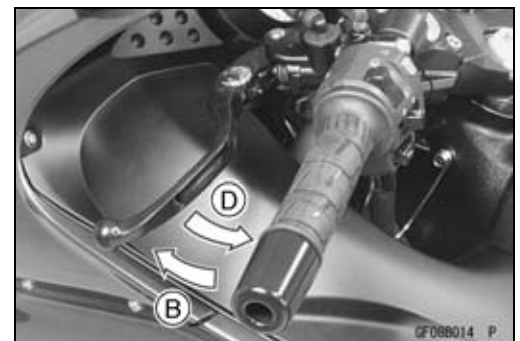
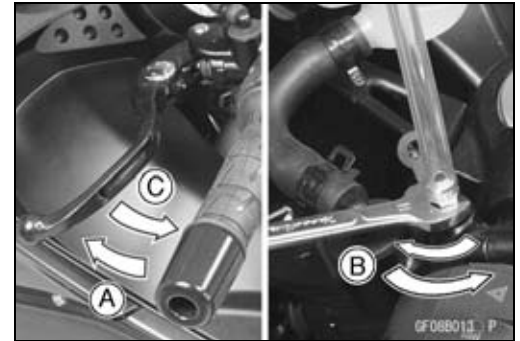

6-12 CLUTCH

Clutch Cover

Clutch Cover Removal

- Remove:
 - Engine Oil (Drain, see Engine Oil Change in the Periodic Maintenance chapter)
 - Right Lower Fairing (see Lower Fairing Removal in the Frame chapter)
 - Clutch Cover Bolts [A]
 - Clutch Cover [B]

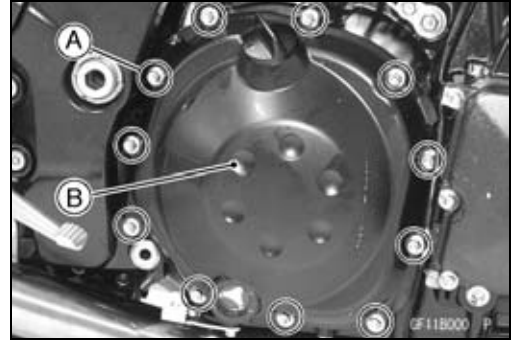

Clutch Cover Installation

- Apply silicone sealant to the area [A] where the mating surface of the crankcase touches the clutch cover gasket.
Sealant - Kawasaki Bond (Silicone Sealant): 92104-0004

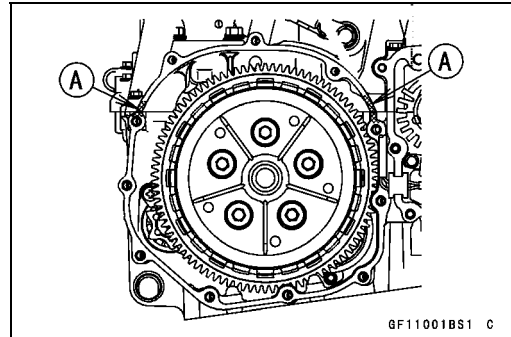

- Replace the clutch cover gasket with a new one.
- Tighten the clutch cover mounting bolts.
- Apply a non-permanent locking agent to only one clutch cover mounting bolt [A] shown in figure.

Torque - Clutch Cover Mounting Bolts: 9.8 N·m (1.0 kgf·m, 87 in·lb)

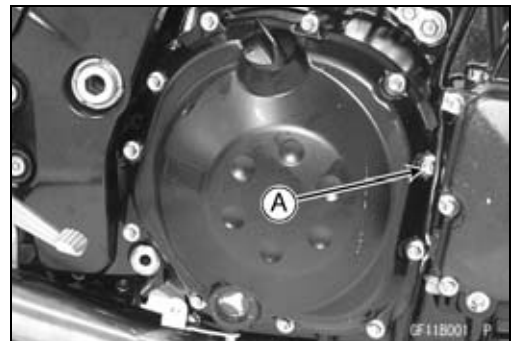

- If the oil gauge [A] is removed, press the gauge so that its projection [B] faces the inside, using lubricant.

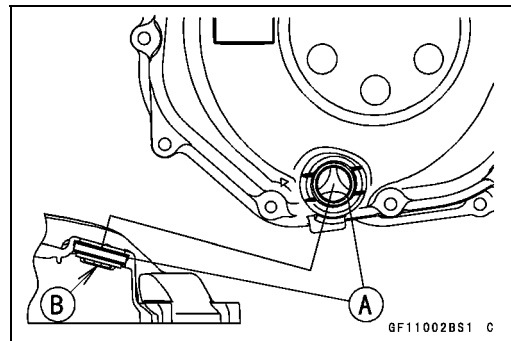

Clutch

Clutch Removal

- Remove:
 - Right Lower Fairing (see Lower Fairing Removal in the Frame chapter)
 - Clutch Cover (see Clutch Cover Removal)
 - Clutch Spring Bolts [A]
 - Clutch Springs
 - Clutch Spring Plate [B] (with thrust bearing, pusher [C] and washer)

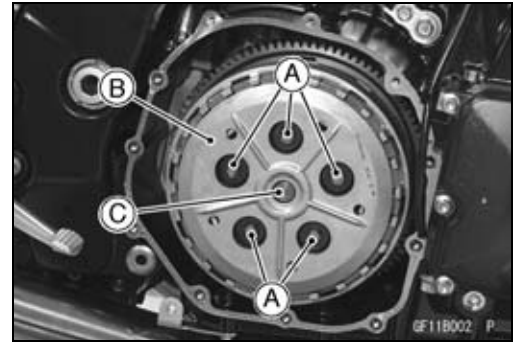

- Remove:
 - Friction Plates [A]
 - Steel Plates
 - Spring
 - Spring Seat



- Holding the clutch hub [A], remove the nut [B] and washers [C]

Special Tool - Clutch Holder: 57001-1243 [D]

- Remove:
 - Clutch Hub
 - Washer

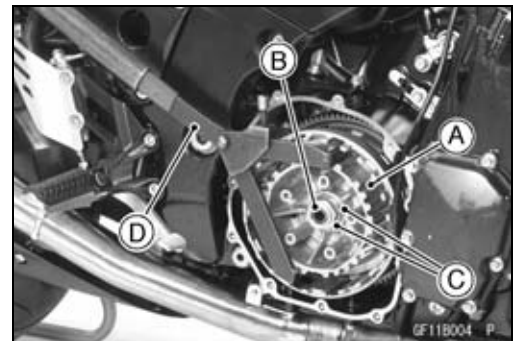

- Insert the clutch gear setting screw to the hole of the clutch housing (see Clutch Installation).
- Position the hole of the clutch housing at the front side of the engine so that the tip of the gear setting does not hit the crankcase wall.
- Align the teeth of the clutch housing gears by the gear setting.

Special Tool - Clutch Gear Setting Screw: 57001-1671

- Pull out the sleeve [B] from the clutch housing [D], and remove the housing.
- If the sleeve does not pull out easily, insert M4 bolts [A] into the threaded hole of the sleeve, and pull out the sleeve and needle bearing [C].
- Remove the thrust washer.

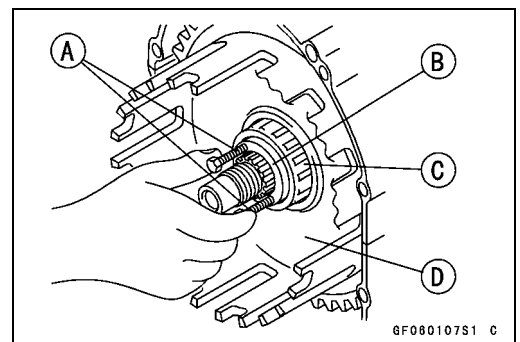

6-14 CLUTCH

Clutch

Clutch Installation

- Install the thrust washer [A] by facing its chamfered side [B] towards the crankcase.

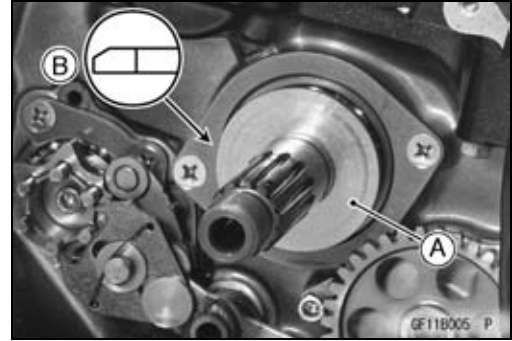

- Align the teeth of the clutch housing gears by the gear setting screw [A].
- Install the clutch housing so that the hole position forward of the engine.

Special Tool - Clutch Gear Setting Screw: 57001-1671

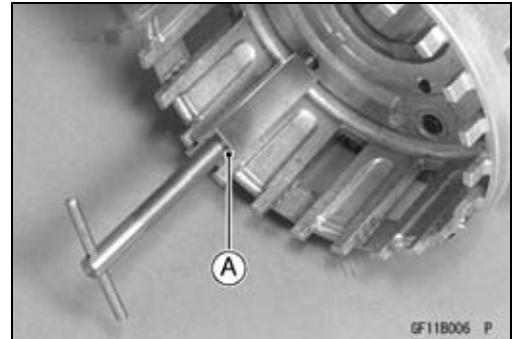

- Install:
 - Clutch Housing
 - Needle Bearing
 - Sleeve
 - Washer [A]
- Apply engine oil to the needle bearing and the sleeve before installation.

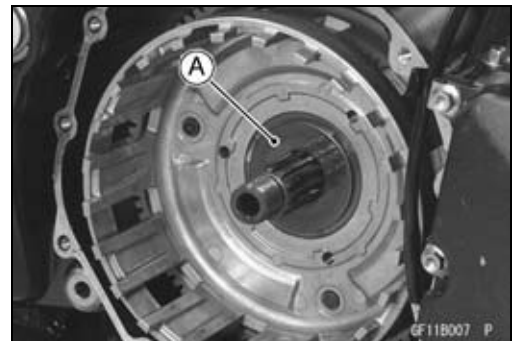

- Install the clutch hub and two washers [A].
- The outside washer has the OUT SIDE mark [B].

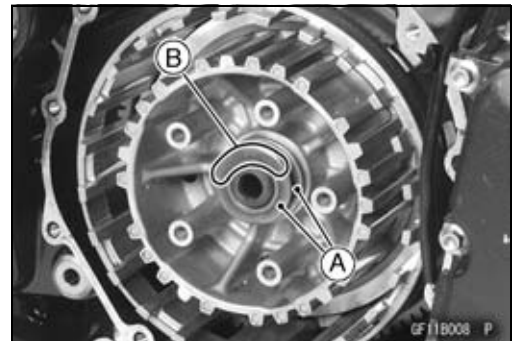

- Replace the clutch hub nut with a new one.
- Holding the clutch hub, tighten the clutch hub nut with the torque wrench.

Special Tool - Clutch Holder: 57001-1243

Torque - Clutch Hub Nut: 135 N·m (14 kgf·m, 100 ft·lb)

Clutch

- Install the spring seat [A], spring [B], friction plates [C] [D] [E] and steel plates [F] as shown.

NOTE

- The inside diameter of first friction plates are larger than the others because the spring seat and spring are equipped to decrease the judder noise as shown.

Clutch Hub [G]

CAUTION

If new dry friction plates and steel plates are installed, apply engine oil to the surfaces of each plate to avoid clutch plate seizure.

- Install outer-end friction plate, that has the large lining blocks [A] among others.

- Install the last friction plate [A] fitting the tangs in the grooves in the housing as shown.

- Apply molybdenum disulfide grease [M] to the outside surface of the pusher [A], then install the pusher into the drive shaft.

- Install the spring, and tighten the clutch spring bolts evenly.

Torque - Clutch Spring Bolts: 8.8 N·m (0.90 kgf·m, 78 in·lb)

- Install the clutch cover (see Clutch Cover Installation).

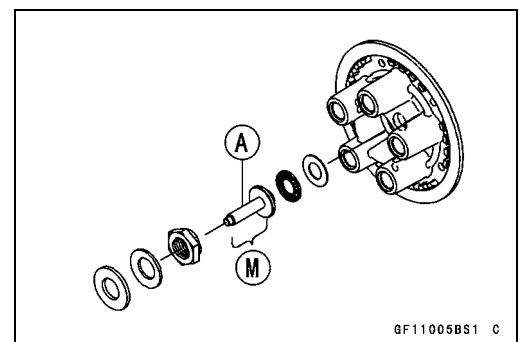
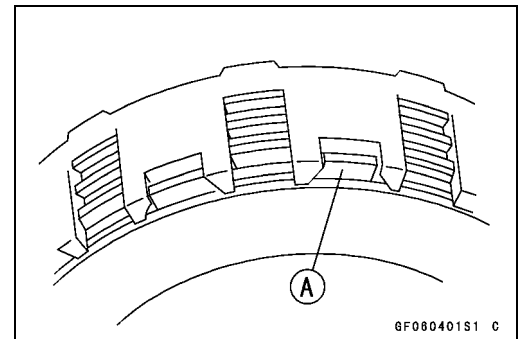
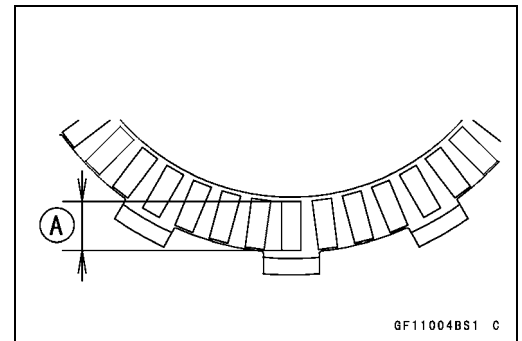
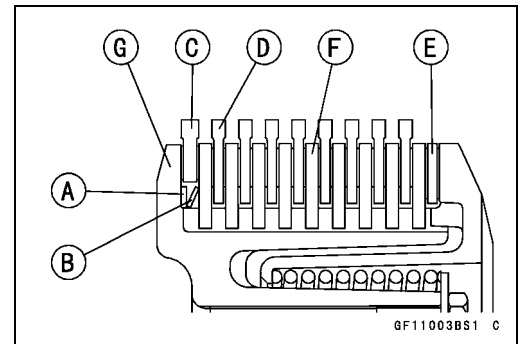

6-16 CLUTCH

Clutch

Clutch Plate Assembly Inspection

- Inspect the friction plate thickness (see Clutch Plate, Wear, Damage Inspection).
- Measure the length [A] of the clutch plate assembly as shown.

○ Assemble:

- Clutch Hub [B]
- Spring Seat [C]
- Spring [D]
- Friction Plates [E] [F] [G]
- Steel Plates [H]
- Spring Plate [J]
- Springs [K]
- Spring Bolts [L]

Torque - Clutch Spring Bolts: 8.8 N·m (0.90 kgf·m, 78 in·lb)

Clutch Plate Assembly Length

Standard: 53.52 ~ 54.52 mm (2.11 ~ 2.15 in.)

- ★ If the length is not within the specified range, adjust the length (see Clutch Plate Assembly Adjustment).

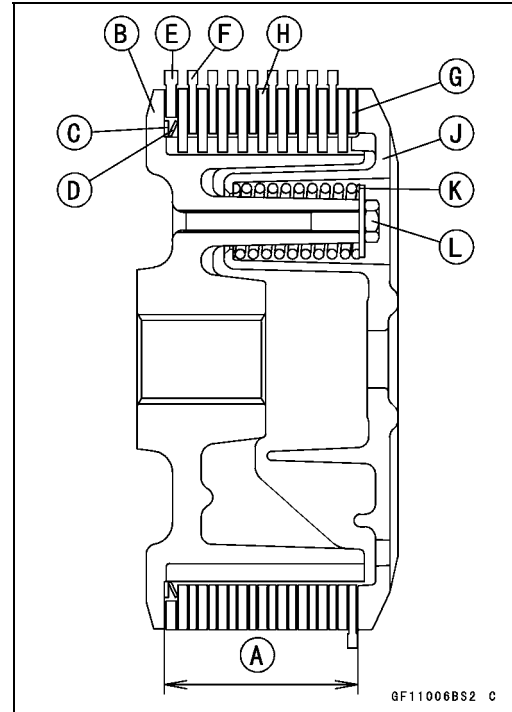

Clutch Plate Assembly Adjustment

- Inspect the clutch plate assembly length, and then replace the steel plate(s) which brings the length within the specified range.

○ Remove:

- Spring Bolts
- Springs
- Spring Plate
- Clutch Plates

○ Replace the following steel plate(s).

Part No.	Thickness
13089-0019	2.3 mm (0.091 in.)
13089-0018	2.6 mm (0.102 in.) (STD)
13089-0020	2.9 mm (0.114 in.)

NOTE

- Do not use the steel plate of 2.9 mm (0.114 in.) and 2.3 mm (0.091 in.) thickness at the same time.
- Install the removed parts, and inspect the clutch plate assembly length.

Torque - Clutch Spring Bolts: 8.8 N·m (0.90 kgf·m, 78 in·lb)

Clutch

Clutch Plate, Wear, Damage Inspection

- Visually inspect the friction and steel plates for signs of seizure, overheating (discoloration), or uneven wear.
- Measure the thickness of each friction plate [A] at several points.
- ★ If any plates show signs of damage, or if they have worn past the service limit, replace them with new ones.

Friction Plate Thickness (13088-0030, 13088-0031)

Standard: 2.92 ~ 3.08 mm (0.115 ~ 0.121 in.)

Service Limit: 2.7 mm (0.106 in.)

Friction Plate Thickness (13088-0032)

Standard: 3.72 ~ 3.88 mm (0.146 ~ 0.153 in.)

Service Limit: 3.5 mm (0.138 in.)

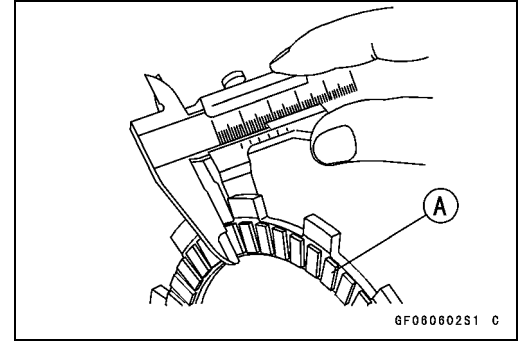

Clutch Plate Warp Inspection

- Place each friction plate or steel plate on a surface plate and measure the gap between the surface plate [A] and each friction plate or steel plate [B] with a thickness gauge [C]. The gap is the amount of friction or steel plate warp.
- ★ If any plate is warped over the service limit, replace it with a new one.

Friction and Steel Plate Warp

Standard: 0.15 mm (0.0059 in.) or less

Service Limit: 0.3 mm (0.012 in.)

Friction Plate Warp (only 13088-0030)

Standard: 0.2 mm (0.008 in.) or less

Service Limit: 0.3 mm (0.012 in.)

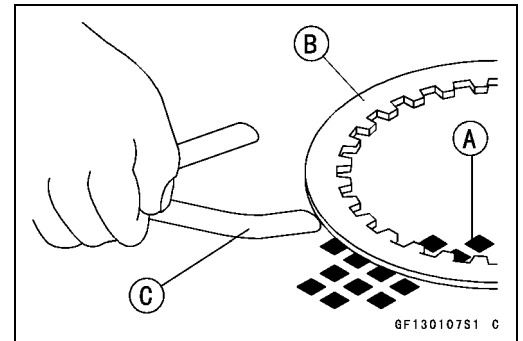

Clutch Spring Free Length Measurement

- Measure the free length of the clutch springs [A].
- ★ If any spring is shorter than the service limit, it must be replaced.

Clutch Spring Free Length

Standard: 65.0 mm (2.56 in.)

Service Limit: 62.0 mm (2.44 in.)

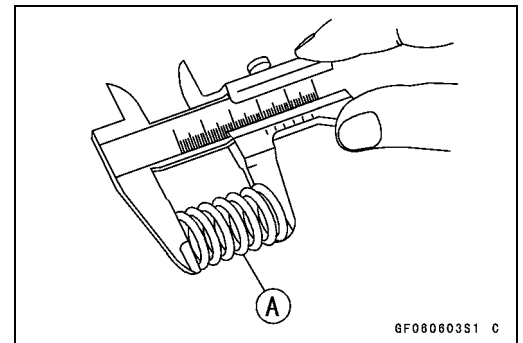

Engine Lubrication System

Table of Contents

Exploded View	7-2
Engine Oil Flow Chart.....	7-4
Specifications	7-6
Special Tools and Sealant	7-7
Engine Oil and Oil Filter.....	7-8
Oil Level Inspection.....	7-8
Engine Oil Change.....	7-8
Oil Filter Replacement	7-8
Oil Pan.....	7-9
Oil Pan Removal.....	7-9
Oil Pan Installation.....	7-9
Oil Pressure Relief Valve.....	7-11
Oil Pressure Relief Valve Removal	7-11
Oil Pressure Relief Valve Installation	7-11
Oil Pressure Relief Valve Inspection.....	7-11
Oil Pump.....	7-12
Oil Pump Removal.....	7-12
Oil Pump Installation	7-12
Oil Cooler.....	7-14
Oil Cooler Removal.....	7-14
Oil Cooler Installation.....	7-14
Oil Pressure Measurement.....	7-15
Oil Pressure Measurement	7-15
Oil Pressure Switch	7-16
Oil Pressure Switch Removal	7-16
Oil Pressure Switch Installation	7-16

ENGINE LUBRICATION SYSTEM 7-3

Exploded View

No.	Fastener	Torque			Remarks
		N·m	kgf·m	ft·lb	
1	Engine Oil Drain Bolt	30	3.0	22	
2	Oil Filter	31	3.2	23	G, R
3	Holder Mounting Bolt	35	3.6	26	L
4	Oil Pan Bolts	9.8	1.0	87 in·lb	
5	Oil Pressure Relief Valve	15	1.5	11	L
6	Oil Pressure Switch	15	1.5	11	SS
7	Oil Pressure Switch Terminal Bolt	1.5	0.15	13 in·lb	G
8	Oil Passage Plug	20	2.0	15	L
9	Oil Pump Cover Bolts	9.8	1.0	87 in·lb	
10	Oil Cooler Mounting Bolts	12	1.2	106 in·lb	S
11	Oil Pan Plate Bolts	9.8	1.0	87 in·lb	L

EO: Apply engine oil.

G: Apply grease.

L: Apply a non-permanent locking agent.

MO: Apply molybdenum disulfide oil.

(mixture of the engine oil and molybdenum disulfide grease in a weight ratio 10 : 1)

R: Replacement Parts

SS: Apply silicone sealant (Kawasaki Bond: 56019-120).

7-4 ENGINE LUBRICATION SYSTEM

Engine Oil Flow Chart

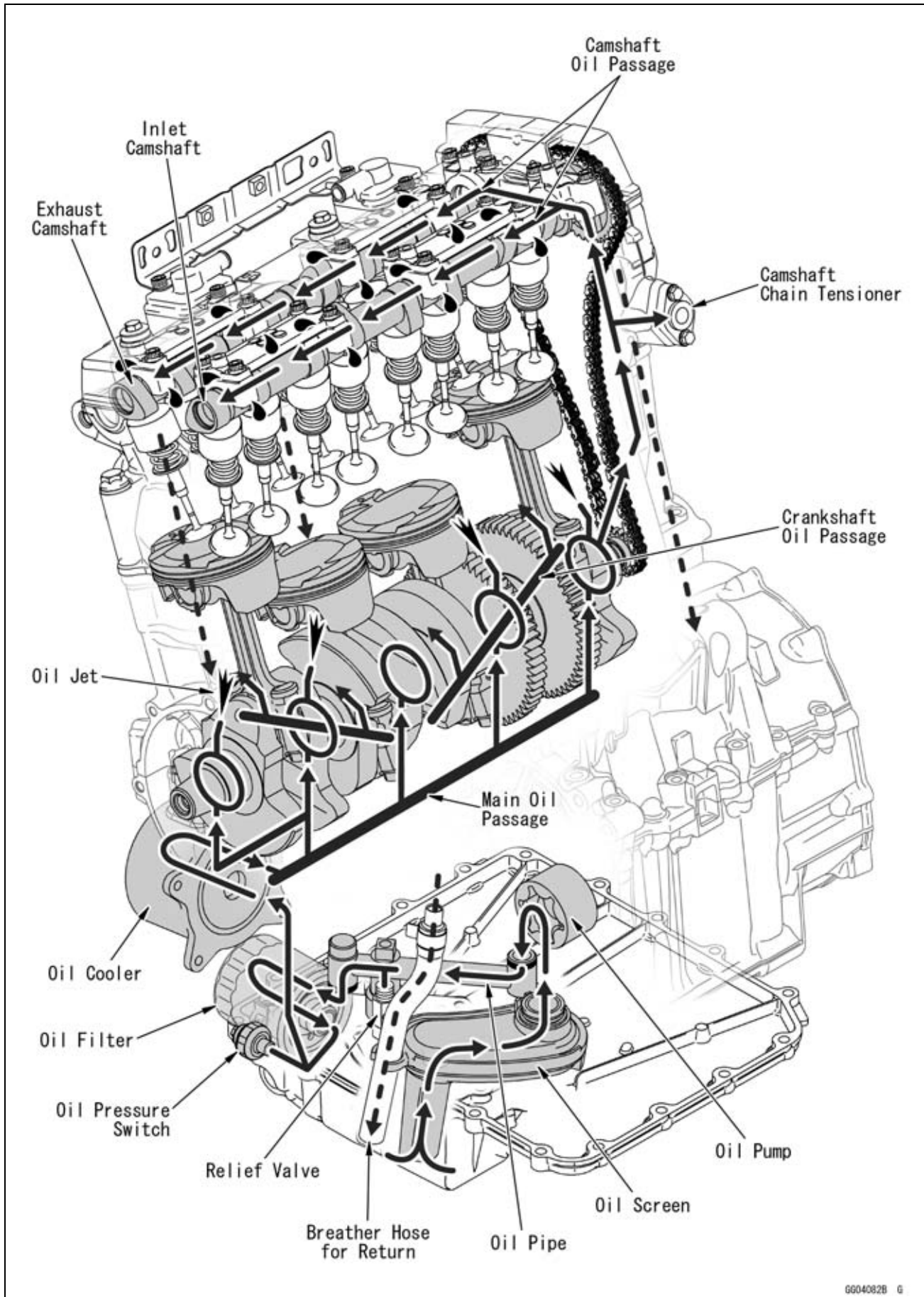

Engine Oil Flow Chart

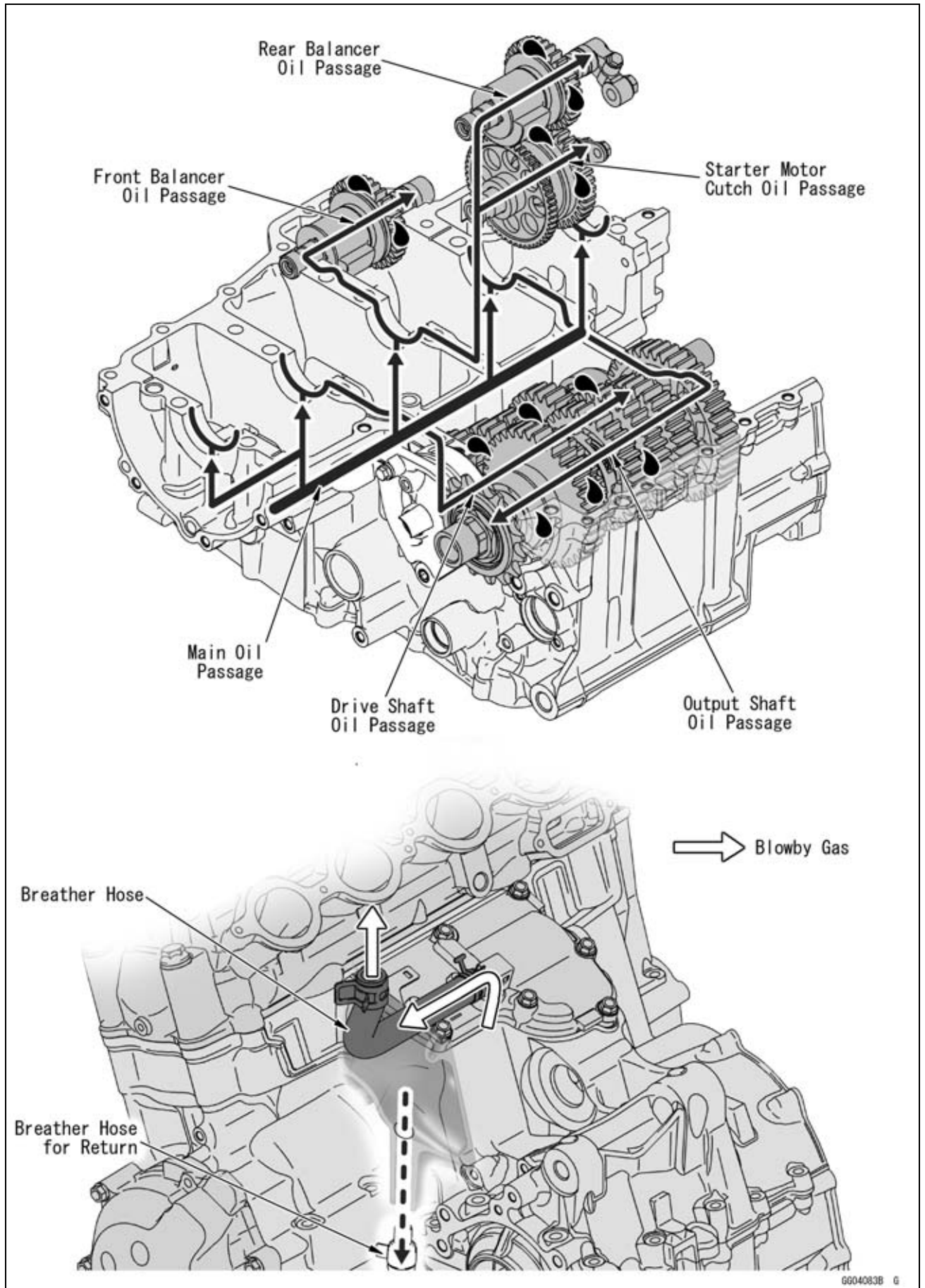

7-6 ENGINE LUBRICATION SYSTEM

Specifications

Item	Standard
Engine Oil Type Viscosity Capacity Level	API SE, SF or SG API SH, SJ or SL with JASO MA SAE 10W-40 3.7 L (3.9 US qt) (when filter is not removed) 4.1 L (4.3 US qt) (when filter is removed) 4.5 L (4.8 US qt) (when engine is completely dry) Between upper and lower level lines
Oil Pressure Measurement Oil Pressure @4 000 r/min (rpm), Oil Temperature 90°C (194°F)	245 ~ 343 kPa (2.5 ~ 3.5 kgf/cm ² , 36 ~ 50 psi)

Special Tools and Sealant

**Oil Pressure Gauge, 10 kgf/cm²:
57001-164**

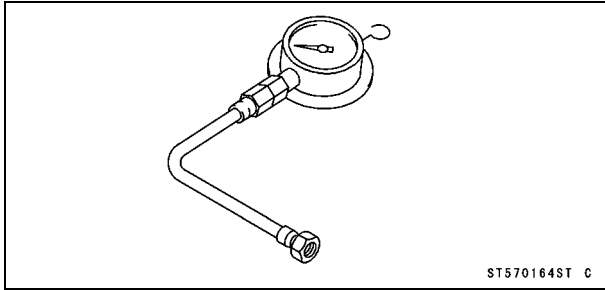

**Oil Filter Wrench:
57001-1249**

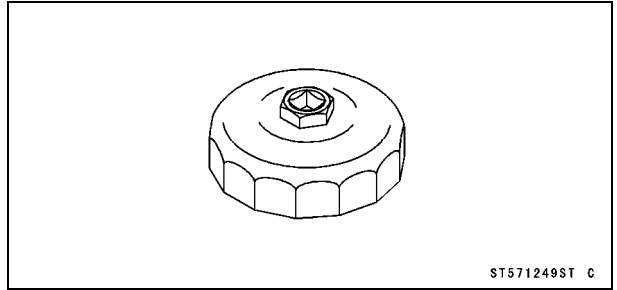

**Oil Pressure Gauge Adapter, PT3/8 × 19/in.:
57001-1233**

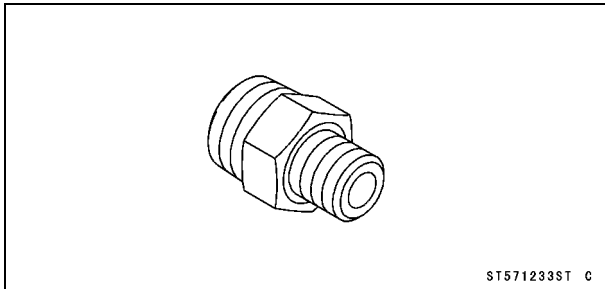

**Kawasaki Bond (Silicone Sealant):
56019-120**

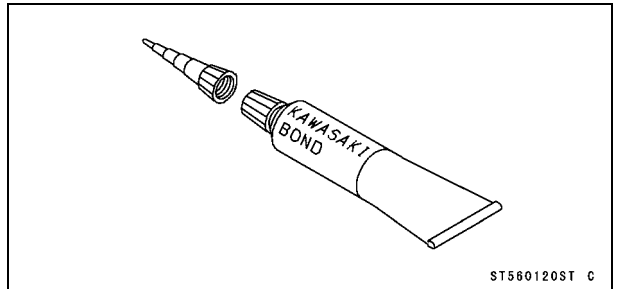

7-8 ENGINE LUBRICATION SYSTEM

Engine Oil and Oil Filter

⚠ WARNING

Motorcycle operation with insufficient, deteriorated, or contaminated engine oil will cause accelerated wear and may result in engine or transmission seizure, accident, and injury.

Oil Level Inspection

- Check that the engine oil level is between the upper [A] and lower [B] levels in the gauge.

NOTE

- Situate the motorcycle so that it is perpendicular to the ground.
- If the motorcycle has just been used, wait several minutes for all the oil to drain down.
- If the oil has just been changed, start the engine and run it for several minutes at idle speed. This fills the oil filter with oil. Stop the engine, then wait several minutes until the oil settles.

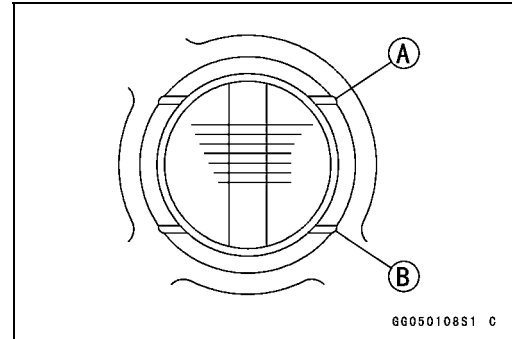

CAUTION

Racing the engine before the oil reaches every part can cause engine seizure.

If the engine oil gets extremely low or if the oil pump or oil passages clog up or otherwise do not function properly, the oil pressure warning light will light. If this light stays on when the engine is running above idle speed, stop the engine immediately and find the cause.

Engine Oil Change

- Refer to the Engine Oil Change in the Periodic Maintenance chapter.

Oil Filter Replacement

- Refer to the Oil Filter Replacement in the Periodic Maintenance chapter.

Oil Pan

Oil Pan Removal

- Remove:
 - Engine Oil (Drain, see Engine Oil Change in the Periodic Maintenance chapter)
 - Muffler Bodies (see Muffler Body Removal/Installation in the Engine Top End chapter)
 - Exhaust Pipe (see Exhaust Pipe Removal in the Engine Top End chapter)
- Disconnect the oil pressure switch terminal [A].
- Remove the oil filter [B] (see Oil Filter Replacement in the Periodic Maintenance chapter).

- Remove:
 - Oil Pan Bolts [A]
 - Oil Pan [B]

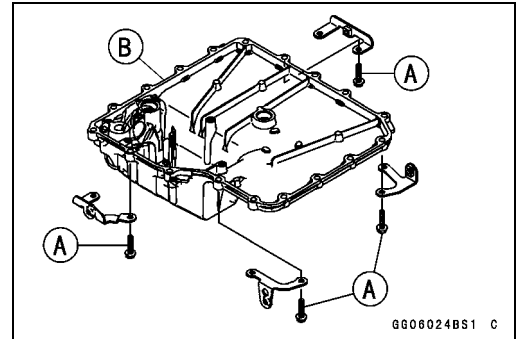
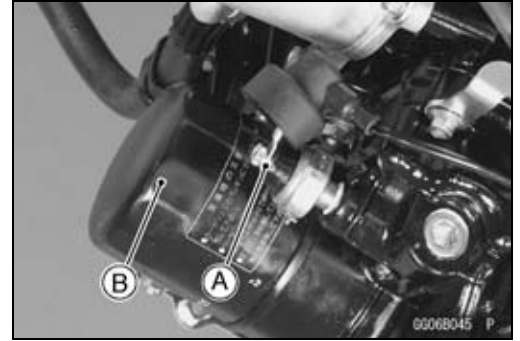

- Remove:
 - Oil Screen [A]
 - Oil Pipe [B]
 - Oil Pressure Relief Valve [C] (if necessary)

CAUTION

Do not remove the relief valve with the oil pipe installed on the lower crankcase half. The oil pipe will be damaged.

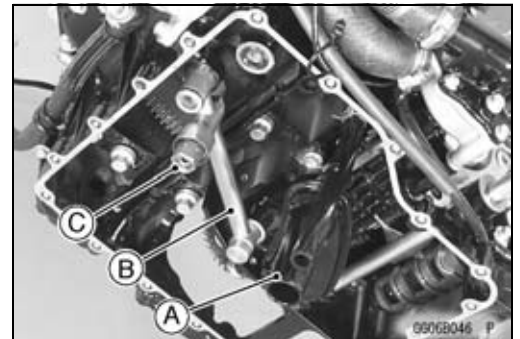

Oil Pan Installation

- Clean the oil screen [A].
- Install the oil screen so that the crankcase rib [B] fits the notch [C] of oil screen.
- Apply grease the oil pipe O-rings and install the oil pipe.
- ★ If the oil pressure relief valve was removed, install it.
- Apply a non-permanent locking agent to the threads of the oil pressure relief valve, and tighten it.

CAUTION

Do not apply too much non-permanent locking agent to the threads. This may block the oil passage.

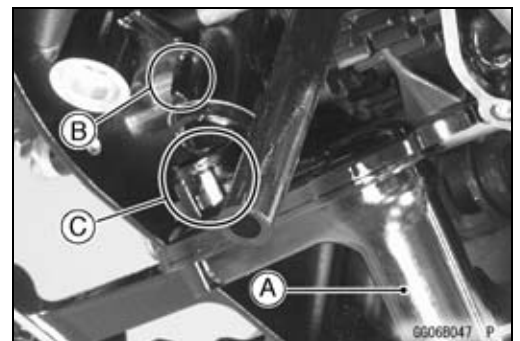

Torque - Oil Pressure Relief Valve: 15 N·m (1.5 kgf·m, 11 ft·lb)

7-10 ENGINE LUBRICATION SYSTEM

Oil Pan

- Put new O-ring [A] on the lower crankcase [B] as shown.
Oil Pipe [C]

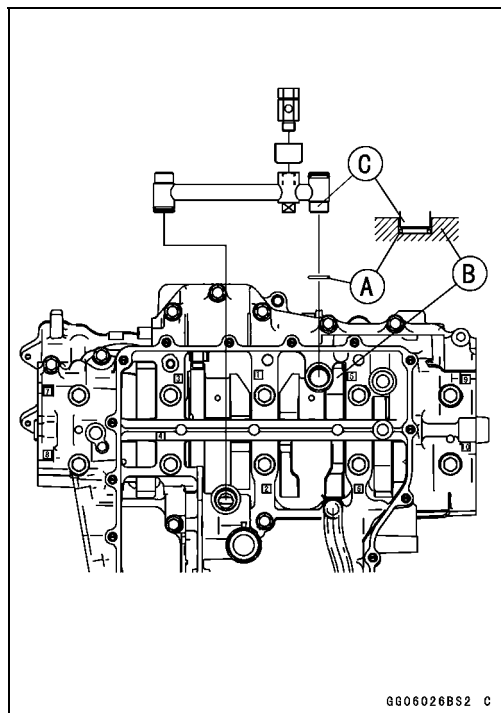

- Install the brackets [A] as shown.
- Replace the oil pan gasket [B] with a new one.
- Tighten:
Torque - Oil Pan Bolts: 9.8 N·m (1.0 kgf·m, 87 in·lb)

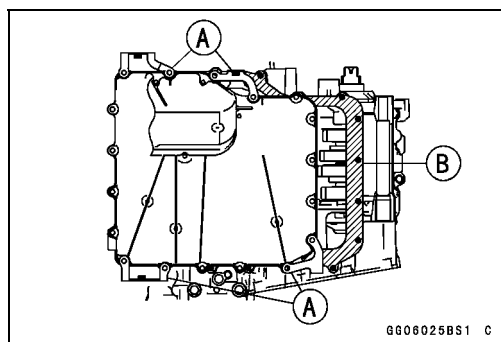

Oil Pressure Relief Valve

Oil Pressure Relief Valve Removal

- See Oil Pan Removal.

Oil Pressure Relief Valve Installation

- See Oil Pan Installation.

Oil Pressure Relief Valve Inspection

- Check to see if the valve [A] slides smoothly when pushing it in with a wooden or other soft rod, and see if it comes back to its seat by spring [B] pressure.

NOTE

○ *Inspect the valve in its assembled state. Disassembly and assembly may change the valve performance.*

- ★ If any rough spots are found during above inspection, wash the valve clean with a high-flash point solvent and blow out any foreign particles that may be in the valve with compressed air.

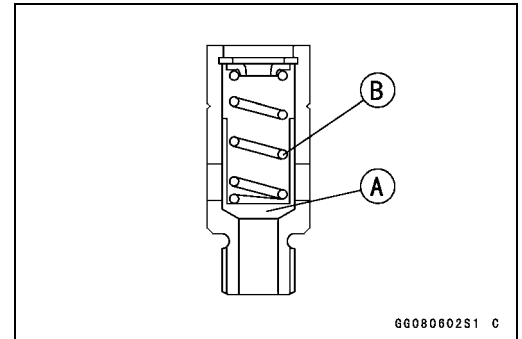

⚠ WARNING

Clean the oil pressure relief valve in a well-ventilated area, and take care that there is no spark or flame anywhere near the working area. Because of the danger of highly flammable liquids, do not use gasoline or low-flash point solvent.

- ★ If cleaning does not solve the problem, replace the oil pressure relief valve as an assembly. The oil pressure relief valve is precision made with no allowance for replacement of individual parts.

7-12 ENGINE LUBRICATION SYSTEM

Oil Pump

Oil Pump Removal

- Drain:
 - Coolant (see Coolant Change in the Periodic Maintenance chapter)
 - Engine Oil (see Engine Oil Change in the Periodic Maintenance chapter)
- Remove:
 - Clutch (see Clutch Removal in the Clutch chapter)
- Remove the oil pump cover bolts [A].
- Remove the oil pump cover [B] with oil pump shaft.
- Remove the outer rotor and inner rotor.

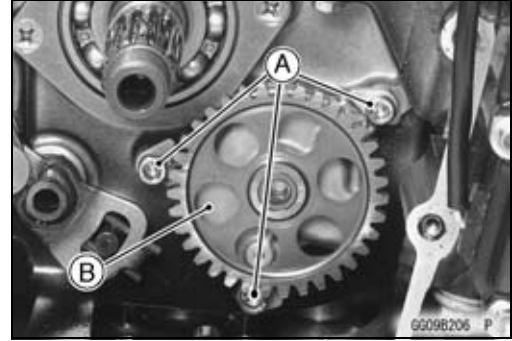

Oil Pump Installation

- Apply molybdenum disulfide oil solution to the journal portions [A] on the oil pump drive gear shaft [B].

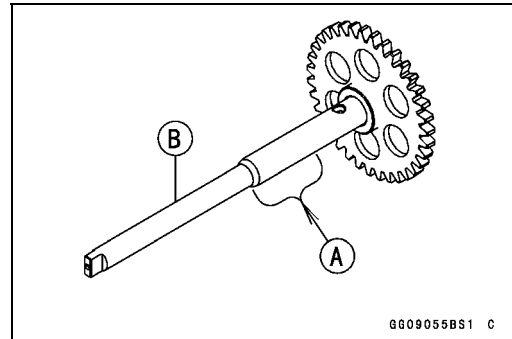

- Insert the outer rotor [A] the dowel pin [B] into the crankcase.

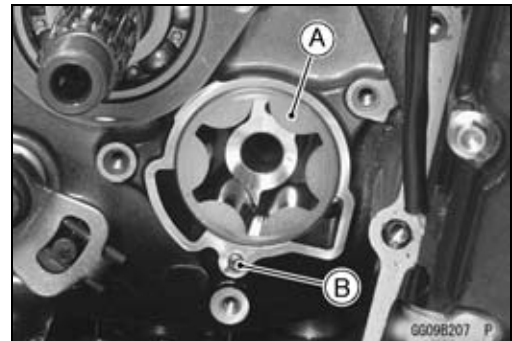

- Insert the pump cover [A], washer [B], pin [C] and inner rotor [D] to the oil pump shaft [E].

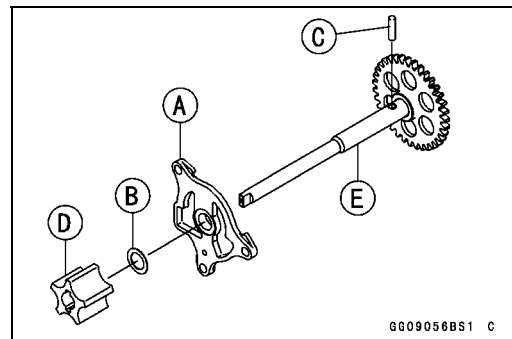

Oil Pump

- Install the oil pump shaft with inner rotor.
- Turn the pump shaft [A] so that the projection [B] in its shaft fits onto the slot [C] of the water pump shaft [D].
- Fit the pin of the oil pump cover into the hole in the crankcase. (in the photo, the oil pan have been removed for clarity)

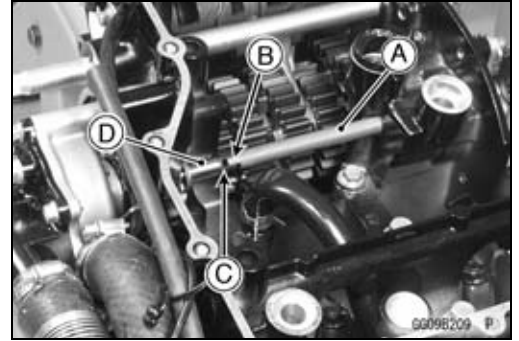

- Tighten:
Torque - Oil Pump Cover Bolts [A]: 9.8 N·m (1.0 kgf·m, 87 in·lb)

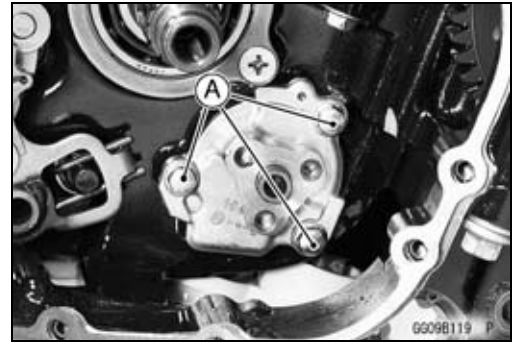

7-14 ENGINE LUBRICATION SYSTEM

Oil Cooler

Oil Cooler Removal

- Remove:
 - Lower Fairings (see Lower Fairing Removal in the Frame chapter)
- Drain:
 - Coolant (see Coolant Change in the Periodic Maintenance chapter)
 - Engine Oil (see Engine Oil Change in the Periodic Maintenance chapter)
- Remove the water hoses from the oil cooler.
- Unscrew the oil cooler mounting bolts [A], and remove the oil cooler [B].

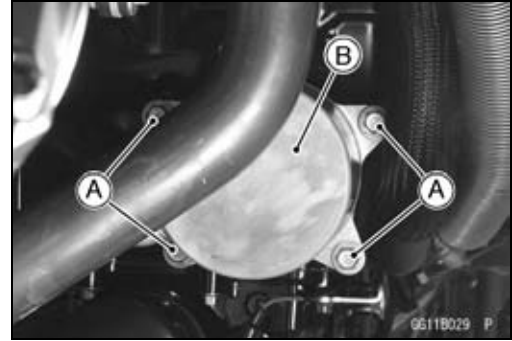

Oil Cooler Installation

- Apply grease to new O-ring [A] before installation.
 - Install the oil cooler to the oil cooler case, and tighten the bolts, following the specified tightening sequence [1 ~ 4].
- Torque - Oil Cooler Mounting Bolts [B]: 12 N·m (1.2 kgf·m, 106 in·lb)**

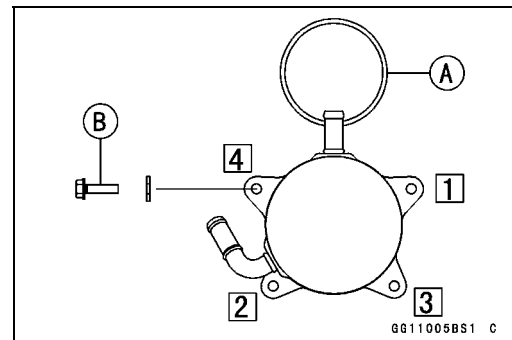

- Install the water hoses as shown.
 - White Mark [A]
- Tighten:
 - Torque - Water Hose Clamp Screws: 2.0 N·m (0.20 kgf·m, 18 in·lb)**
- Pour:
 - Engine Oil (see Engine Oil Change in the Periodic Maintenance chapter)
 - Coolant (see Coolant Change in the Periodic Maintenance chapter)

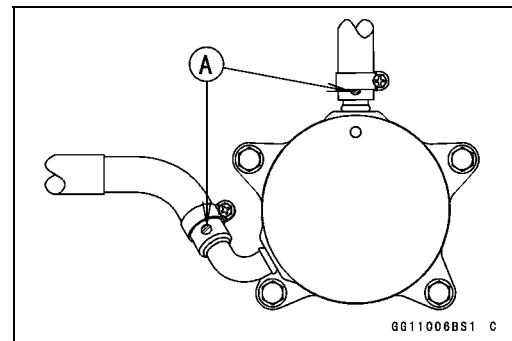

Oil Pressure Measurement

Oil Pressure Measurement

- Remove the left lower fairing (see Lower Fairing Removal in the Frame chapter).
- Remove the oil passage plug, and attach the adapter [A] and gauge [B] to the plug hole.

Special Tools - Oil Pressure Gauge, 10 kgf/cm²: 57001-164
Oil Pressure Gauge Adapter, PT3/8 × 19/in.: 57001-1233



- Start the engine and warm up the engine.
- Run the engine at the specified speed, and read the oil pressure gauge.
- ★ If the oil pressure is much lower than the standard, check the oil pump, relief valve, and/or crankshaft bearing insert wear immediately.
- ★ If the reading is much higher than the standard, check the oil passages for clogging.

Oil Pressure

Standard: 245 ~ 343 kPa (2.5 ~ 3.5 kgf/cm², 36 ~ 50 psi) @ 4 000 r/min (rpm), oil temperature 90°C (194°F)

- Stop the engine.
- Remove the oil pressure gauge and adapter.

⚠ WARNING

Take care against burns from hot engine oil that will drain through the oil passage when the gauge adapter is removed.

- Apply a non-permanent locking agent to the oil passage plug, and install it.

Torque - Oil Passage Plug: 20 N·m (2.0 kgf·m, 15 ft·lb)

7-16 ENGINE LUBRICATION SYSTEM

Oil Pressure Switch

Oil Pressure Switch Removal

- Remove:
 - Engine Oil (Drain, see Engine Oil Change in the Periodic Maintenance chapter)
 - Left Lower Fairing (see Lower Fairing Removal in the Frame chapter)
 - Switch Cover [A]
 - Switch Terminal [B]
 - Oil Pressure Switch [C]

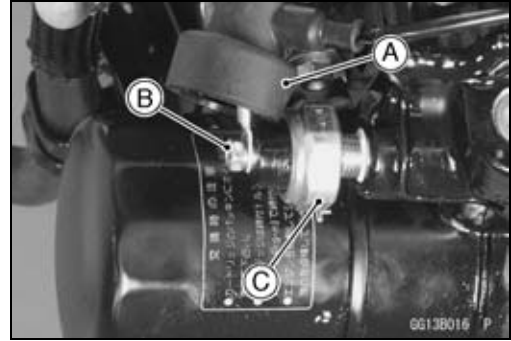

Oil Pressure Switch Installation

- Apply silicone sealant to the threads of the oil pressure switch and tighten it.

Sealant - Kawasaki Bond (Silicone Sealant): 56019-120

Torque - Oil Pressure Switch: 15 N·m (1.5 kgf·m, 11 ft·lb)

- Install the switch lead direction [A] upward.
- Apply grease [B] to the terminal.
- Tighten the terminal bolt.

Torque - Oil Pressure Switch Terminal Bolt: 1.5 N·m (0.15 kgf·m, 13 in·lb)

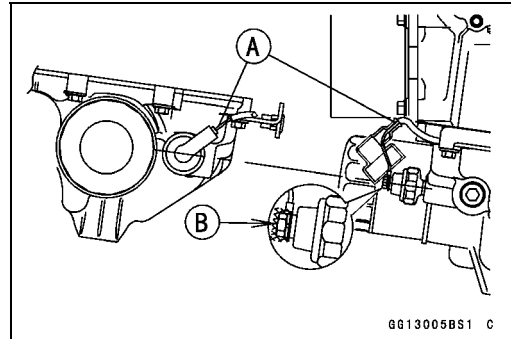

NOTE

- Apply a small amount grease to the terminal so that grease should not close two breather holes [A] for switch diaphragm.

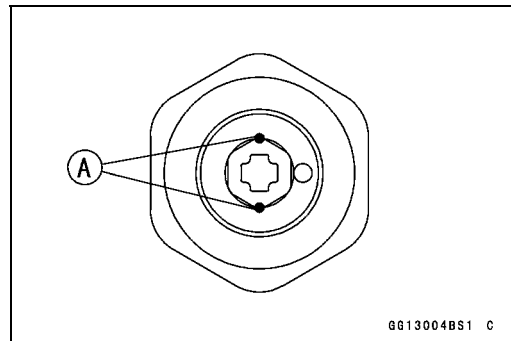

Engine Removal/Installation

Table of Contents

Exploded View.....	8-2
Engine Removal/Installation.....	8-4
Engine Removal.....	8-4
Engine Installation.....	8-6

8-2 ENGINE REMOVAL/INSTALLATION

Exploded View

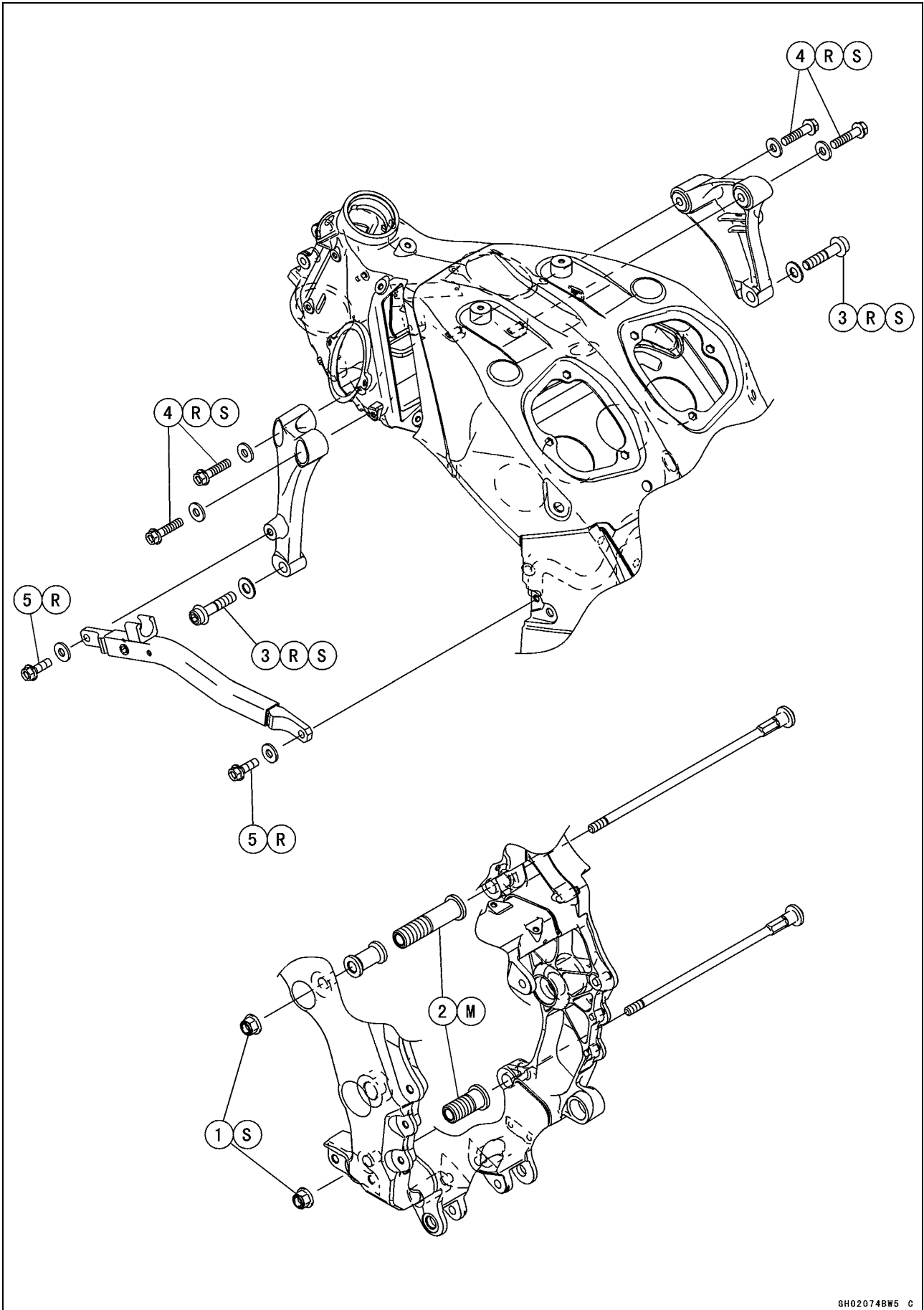

ENGINE REMOVAL/INSTALLATION 8-3

Exploded View

No.	Fastener	Torque			Remarks
		N·m	kgf·m	ft·lb	
1	Engine Mounting Nuts (M12)	59	6.0	44	S
2	Adjusting Collars	25	2.5	18	M
3	Front Engine Mounting Bolts (M10)	59	6.0	44	S, R
4	Engine Bracket Bolts (M8)	25	2.5	18	S, R
5	Subframe Bolts	23	2.3	17	R

M: Apply molybdenum sulfide grease.

R: Replacement Parts

S: Follow the specified tightening sequence.

8-4 ENGINE REMOVAL/INSTALLATION

Engine Removal/Installation

Engine Removal

- Support the rear part of the swingarm with a stand.
- Squeeze the brake lever slowly and hold it with a band [A].

⚠ WARNING

Be sure to hold the front brake when removing the engine, or the motorcycle may fall over. It could cause an accident and injury.

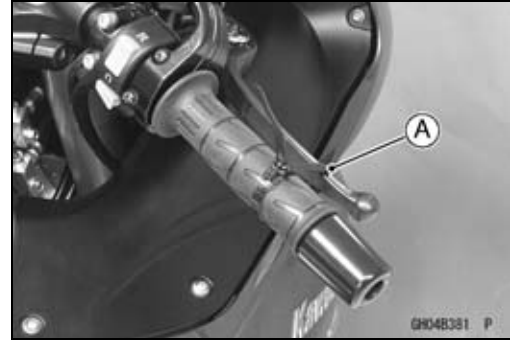

CAUTION

Be sure to hold the front brake when removing the engine, or the motorcycle may fall over. The engine or the motorcycle could be damaged.

- Drain:
 - Engine Oil (see Engine Oil Change in the Periodic Maintenance chapter)
 - Coolant (see Coolant Change in the Periodic Maintenance chapter)
- Remove:
 - Lower Fairings (see Lower Fairing Removal in the Frame chapter)
 - Middle Fairings (see Middle Fairing Removal in the Frame chapter)
 - Fuel Tank (see Fuel Tank Removal in the Fuel System (DFI) chapter)
 - Coolant Reserve Tank
 - Clutch Slave Cylinder (see Clutch Slave Cylinder Removal in the Clutch chapter)
 - Radiator (see Radiator and Radiator Fan Removal in the Cooling System chapter)
 - Muffler Bodies (see Muffler Body Removal/Installation in the Frame chapter)
 - Exhaust Pipe (see Exhaust Pipe Removal in the Engine Top End chapter)
 - Shift Pedal (see Shift Pedal Removal in the Crankshaft/Transmission chapter)
- Disconnect:
 - Sidestand Switch Lead Connector [A]
 - Oil Pressure Switch/Gear Position Switch Leads Connector [B]

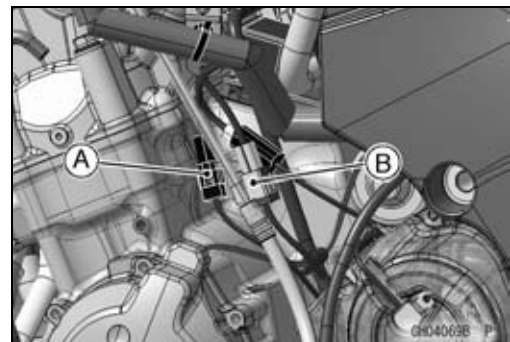

Engine Removal/Installation

- Disconnect the alternator lead conductor [A].

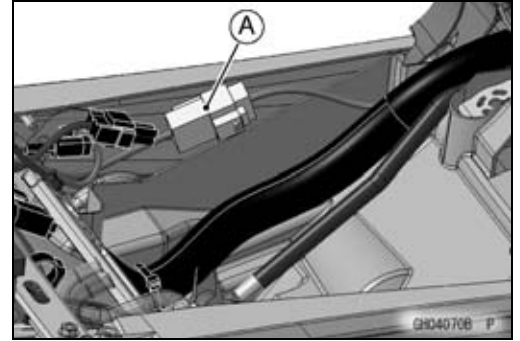

- Remove:
 - Connector [A] of Subharness for Sensor and Valve (disconnect)
 - Subframe Bolts [B]
 - Subframe Bracket Bolt [C]
- Remove the subframe [D] with the clutch pipe [E].

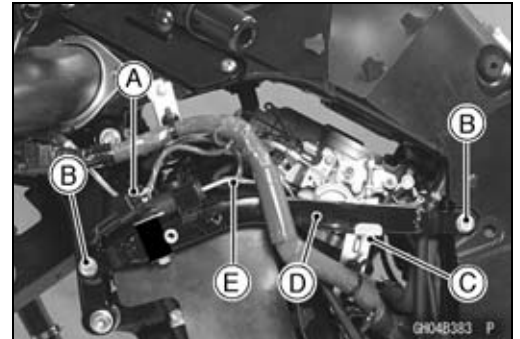

- Disconnect:
 - Throttle Body Subharness Connector [A]
 - Breather Hose [B]
 - Fuel Hose [C] on the Delivery Pipe
 - Throttle Cable Lower Ends [D]

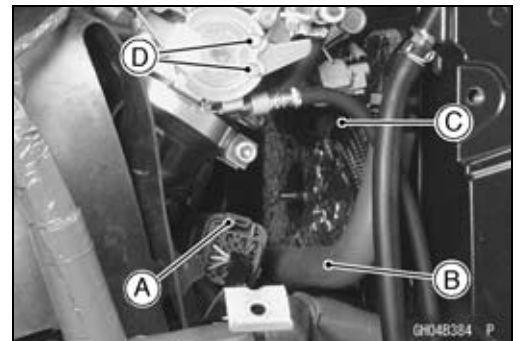

- Remove the bracket Bolt [A].
- Disconnect:
 - Air Switching Valve Connector [B]
 - Stick Coil Subharness Connector [C]

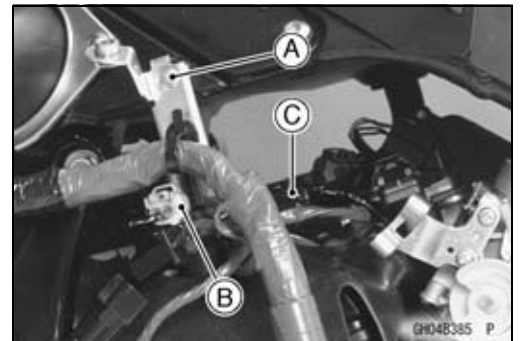

- Remove the air switching valve [A] with hoses.
- Remove the air suction cover (see Air Suction Valve Removal in the Engine Top End chapter).

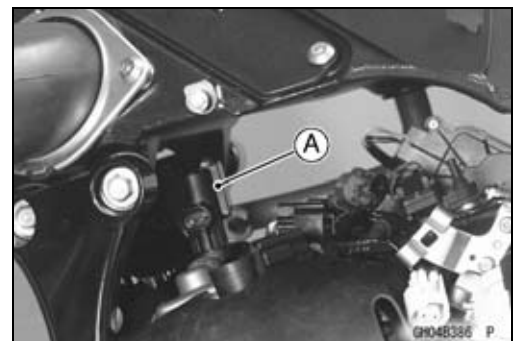

8-6 ENGINE REMOVAL/INSTALLATION

Engine Removal/Installation

- Remove the engine sprocket [A] (see Engine Sprocket Removal in the Final Drive chapter).
- Support the engine with a suitable stand [B].
- Put a plank [C] onto the suitable stand for engine balance.

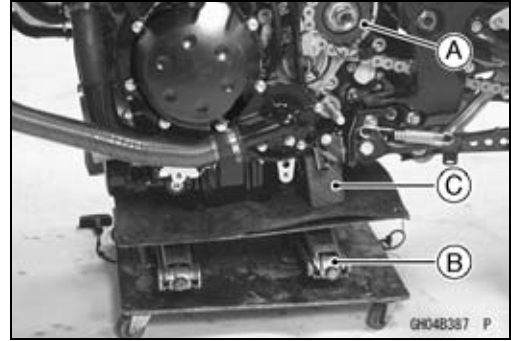

- Remove:
 - Engine Bracket Bolts [A]
 - Front Engine Mounting Bolts [B]
 - Engine Bracket [C]

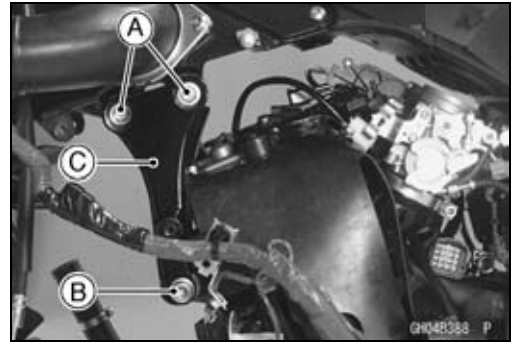

- Remove:
 - Engine Mounting Nuts [A]

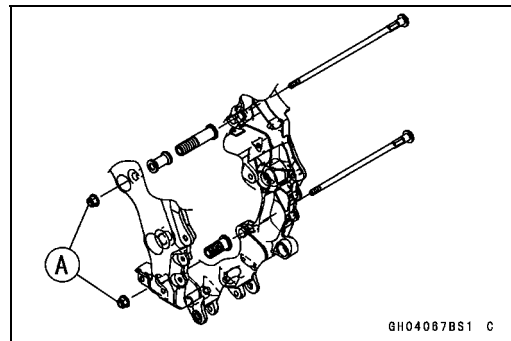

- Disconnect the engine ground terminal [A].
- Using a hexagon wrench, turn the engine mounting bolts [B] clockwise to make the gap between the engine and frame.



- Remove the drive chain from the output shaft.
- Remove the starter motor cable terminal nut [A].
- Using the stand, take out the engine.



Engine Installation

- Support the engine with a suitable stand.
- Put a plank onto the suitable stand for engine balance.
- Install the heat insulation rubber plate.

Engine Removal/Installation

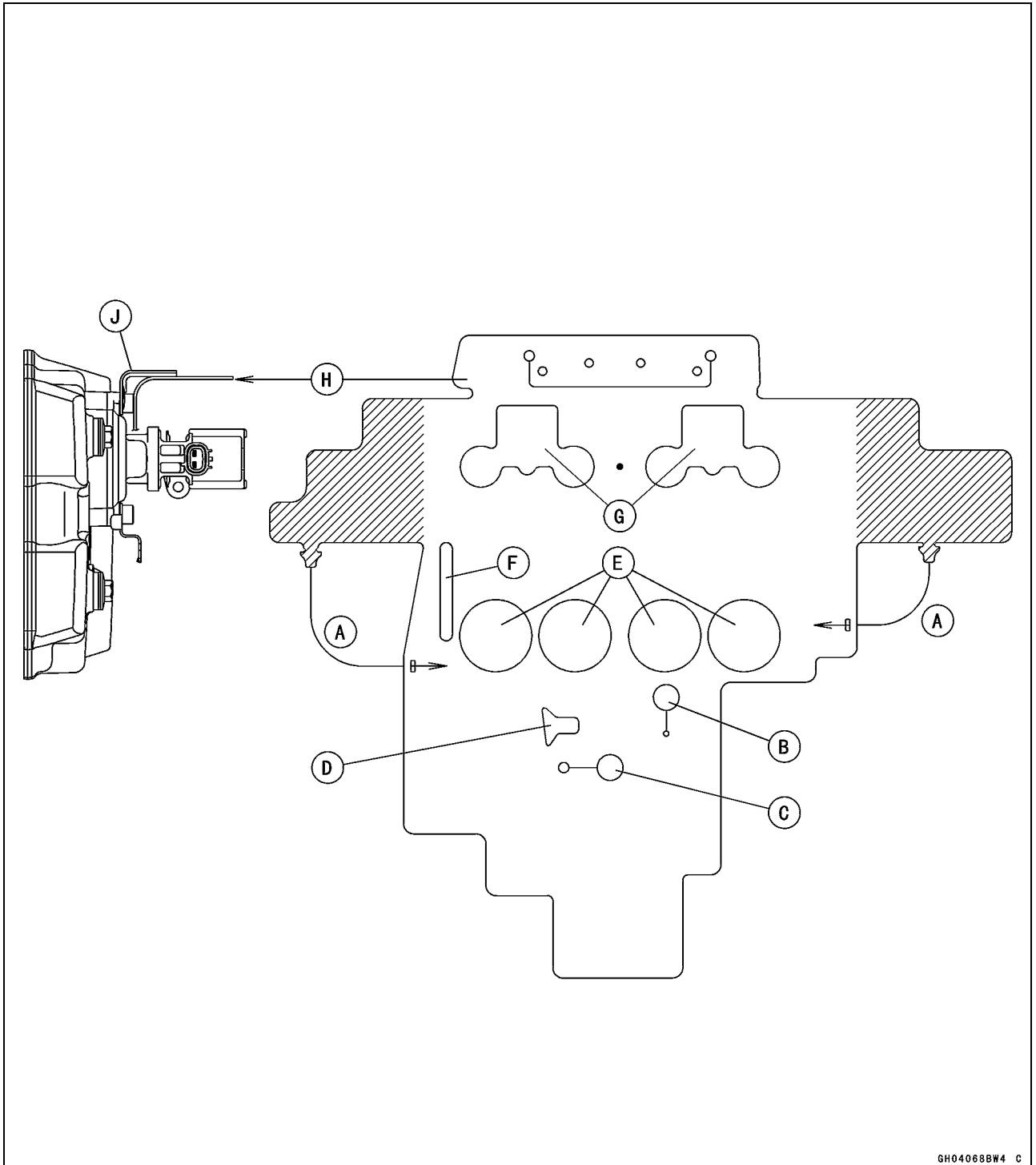

GH04068BW4 C

- A: After installation, set the projection in the hole.
- B: To Water Temperature Sensor
- C: To Breather Hose
- D: To Throttle Body Subharness Bracket
- E: To throttle Body Holder
- F: To Throttle Pulley
- G: To Air Suction Valve and Stick Coils
- H: Only put the heat insulation rubber plate on the cylinder head cover.
- J: Bracket on Air Suction Valve Cover

8-8 ENGINE REMOVAL/INSTALLATION

Engine Removal/Installation

- Before installing the engine. Confirm the routing of the water temperature sensor lead [A].
- Run [B] the water temperature sensor lead between the #3 and #4 cylinder and connect the water temperature sensor body.

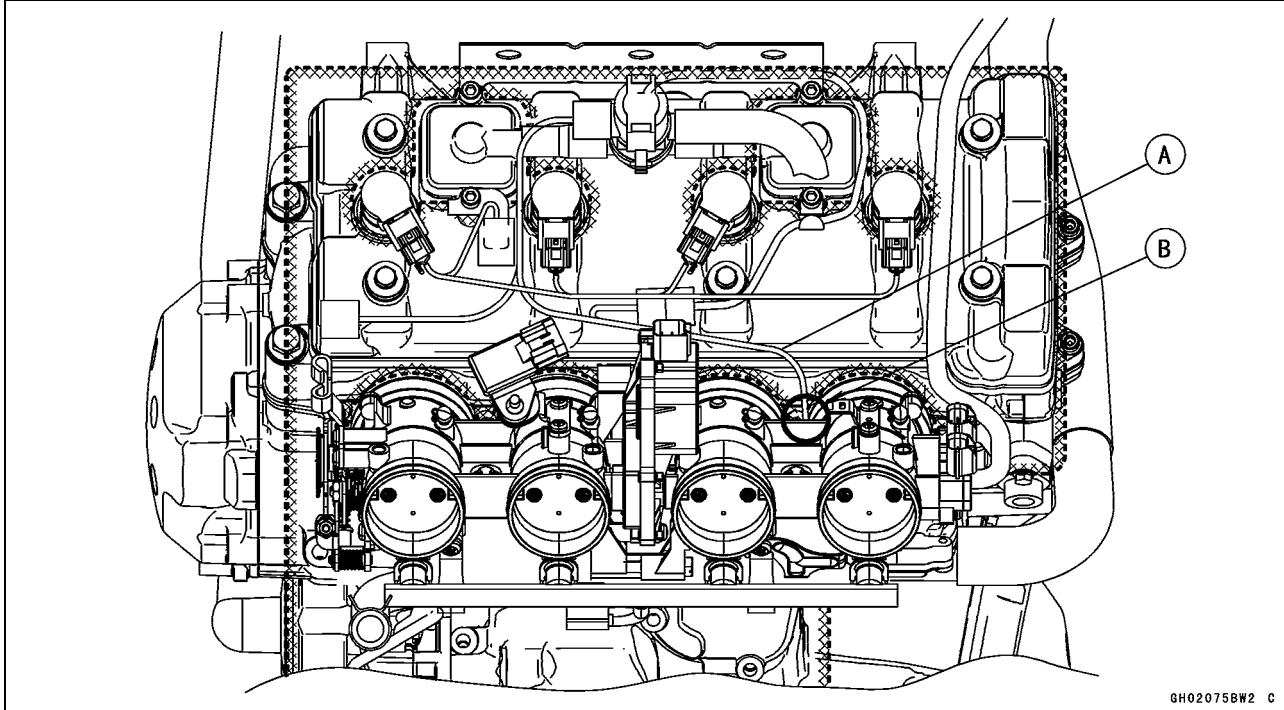

- Install the engine mounting bolts and nuts, following the specified installing sequence.
- Apply molybdenum disulfide grease [A] to the thread of adjusting collars.
- First, tighten the adjusting collars fully by hand.
 - Upper Adjusting Collar [B]
 - Upper Crankcase [C]
 - Lower Adjusting Collar [D]
 - Lower Crankcase [E]

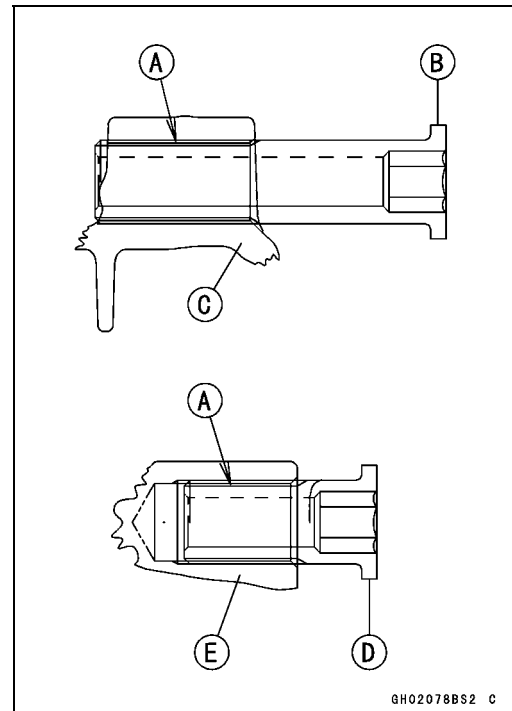

Engine Removal/Installation

- Secondly, insert the mounting bolts [A] until they fit [B] in the adjusting collars [C].
- Be sure that the collar [D] is in position.

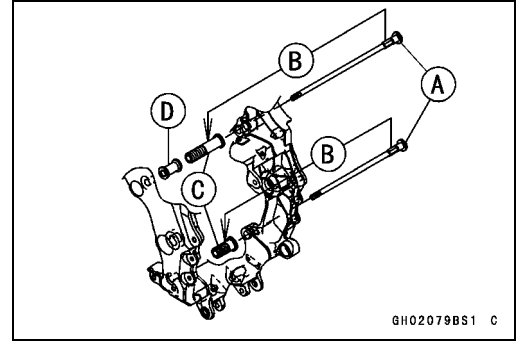

NOTE

- Replace the following bolts with new bolts pre-coated with locking agent.
 - Engine Bracket Bolts (P/No. 92153-1724)
 - Front Engine Mounting Bolts (P/No. 92153-1723)
 - Subframe Bolts (P/No. 92153-1722)
- Thirdly, install the left engine bracket [A] and temporarily tighten the left engine bracket bolts [B].
- Fourthly, tighten the left front engine mounting bolt [C].

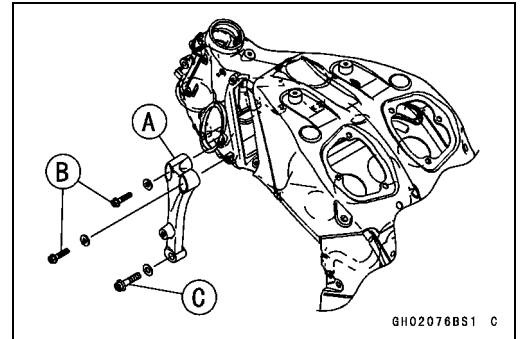

- Fourthly, turn the mounting bolts [A] counterclockwise with specified torque until the clearance [B] between the crankcase [C] and swingarm [D] comes to zero mm [E].
- Adjusting Collars [F]

Torque - Adjusting Collars: 25 N·m (2.5 kgf·m, 18 ft·lb)

- Do not exceed the specified torque of adjusting collars.

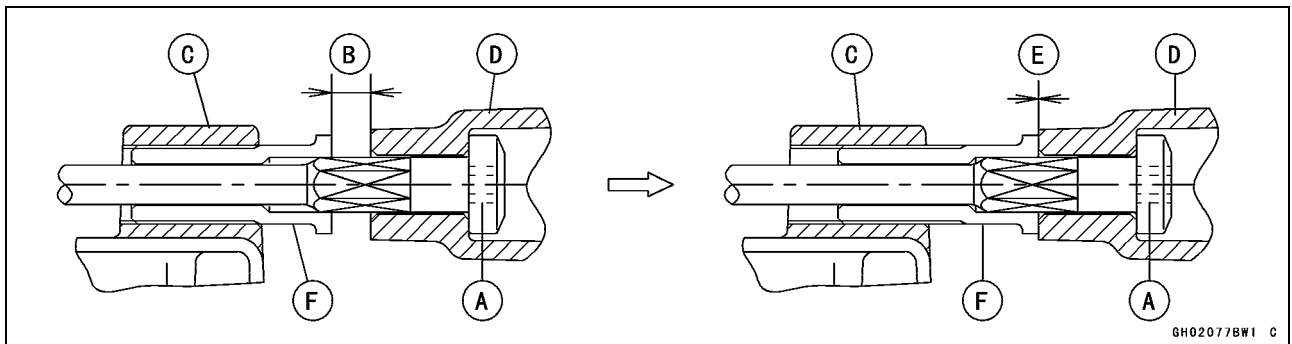

8-10 ENGINE REMOVAL/INSTALLATION

Engine Removal/Installation

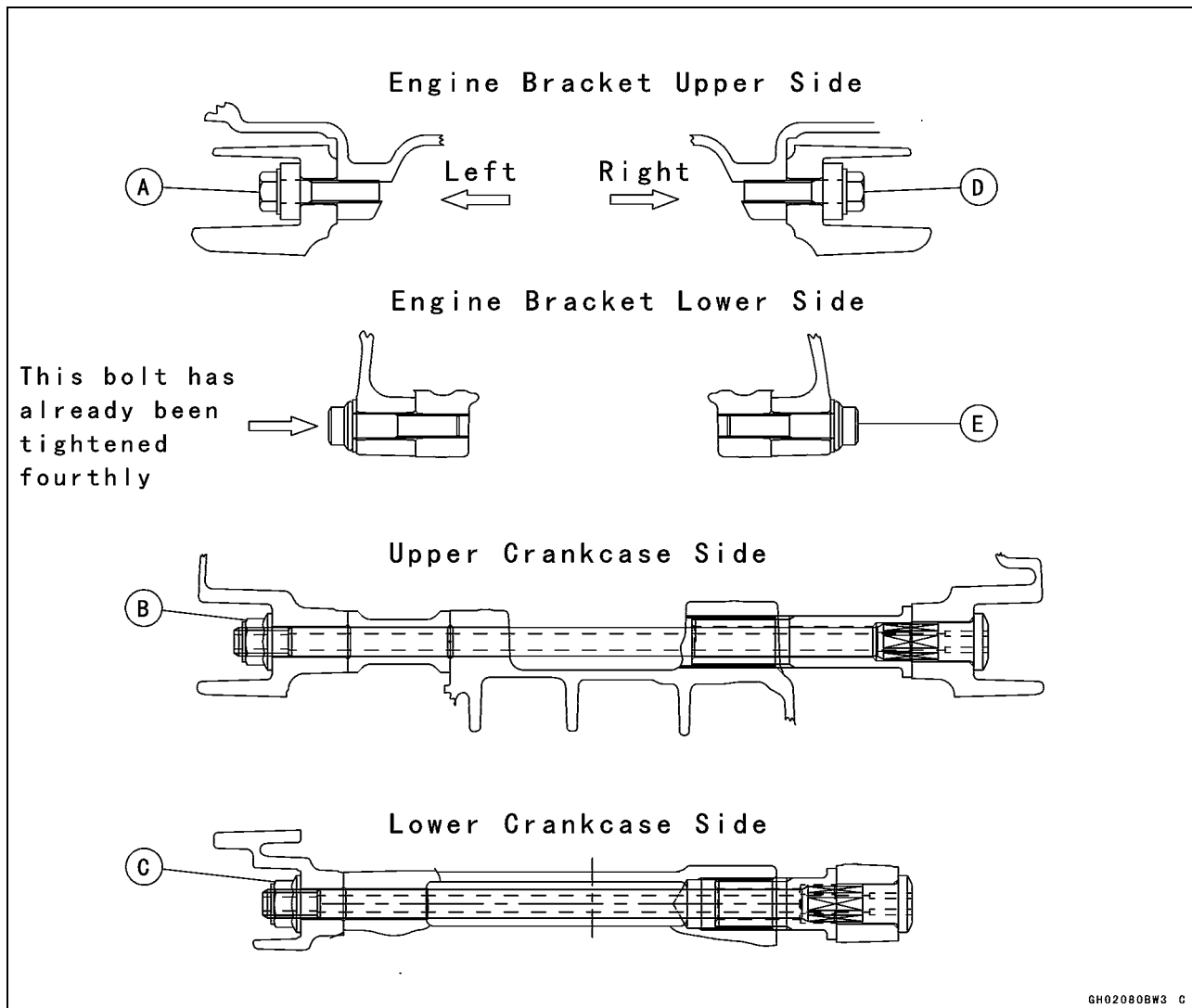

- Fifthly, tighten the left engine bracket bolts [A].
- Sixthly, tighten the upper engine mounting nut [B] and then the lower engine mounting nut [C].
- Seventhly, install the right engine bracket and tighten the right engine bracket bolts [D] and the right front engine mounting bolt [E].
- Torque:

Torque - Engine Mounting Nut (M12): 59 N·m (6.0 kgf·m, 44 ft·lb)

NOTE

- Hold the upper and lower engine mounting bolts with an Allen wrench, and torque them.
- Torque:
 - Torque - Engine Bracket Bolts (M8): 25 N·m (2.5 kgf·m, 18 ft·lb)**
 - Front Engine Mounting Bolts (M10): 59 N·m (6.0 kgf·m, 44 ft·lb)**

Engine Removal/Installation

- Run the leads, cable and hoses correctly (see Cable, Wire, and Hose Routing section in the Appendix chapter).
- Install the removed parts (see appropriate chapters).
- Adjust:
 - Throttle Cables (see Throttle Control System Inspection in the Periodic Maintenance chapter)
 - Drive Chain (see Drive Chain Slack Inspection in the Periodic Maintenance chapter)
- Fill the engine with engine oil (see Engine Oil Change in the Periodic Maintenance chapter).
- Fill the engine with coolant and bleed the air from the cooling system (see Coolant Change in the Periodic Maintenance chapter).

Crankshaft/Transmission

Table of Contents

Exploded View	9-2	Rear Balancer Removal	9-31
Specifications	9-6	Rear Balancer Installation	9-32
Special Tools and Sealants	9-9	Balancer Adjustment	9-34
Crankcase Splitting	9-10	Balancer Damper Inspection	9-34
Crankcase Splitting	9-10	Starter Motor Clutch and Torque	
Crankcase Assembly	9-11	Limiter	9-35
Crankshaft and Connecting Rods	9-15	Starter Motor Clutch Removal	9-35
Crankshaft Removal	9-15	Starter Motor Clutch Installation	9-35
Crankshaft Installation	9-15	Starter Motor Clutch Disassembly	9-35
Connecting Rod Removal	9-16	Starter Motor Clutch Assembly	9-36
Connecting Rod Installation	9-16	Starter Clutch Inspection	9-36
Crankshaft/Connecting Rod		Torque Limiter Removal	9-36
Cleaning	9-19	Torque Limiter Installation	9-37
Connecting Rod Bend	9-19	Transmission	9-38
Connecting Rod Twist	9-20	Shift Pedal Removal	9-38
Connecting Rod Big End Side		Shift Pedal Installation	9-38
Clearance	9-20	External Shift Mechanism	
Connecting Rod Big End Bearing		Removal	9-38
Insert/Crankpin Wear	9-20	External Shift Mechanism	
Crankshaft Side Clearance	9-22	Installation	9-39
Crankshaft Runout	9-23	External Shift Mechanism	
Crankshaft Main Bearing		Inspection	9-39
Insert/Journal Wear	9-23	Transmission Shaft Removal	9-39
Pistons	9-26	Transmission Shaft Installation	9-40
Piston Removal	9-26	Transmission Shaft Disassembly	9-40
Piston Installation	9-27	Transmission Shaft Assembly	9-41
Cylinder Wear (Upper		Shift Drum and Fork Removal	9-44
Crankcase)	9-28	Shift Drum and Fork Installation	9-44
Piston Wear	9-28	Shift Drum Disassembly	9-44
Piston Ring, Piston Ring Groove		Shift Drum Assembly	9-44
Wear	9-28	Shift Fork Bending	9-45
Piston Ring Groove Width	9-29	Shift Fork/Gear Groove Wear	9-45
Piston Ring Thickness	9-29	Shift Fork Guide Pin/Drum	
Piston Ring End Gap	9-29	Groove Wear	9-45
Balancer	9-30	Gear Dog and Gear Dog Hole	
Front Balancer Removal	9-30	Damage	9-45
Front Balancer Installation	9-30		

9-2 CRANKSHAFT/TRANSMISSION

Exploded View

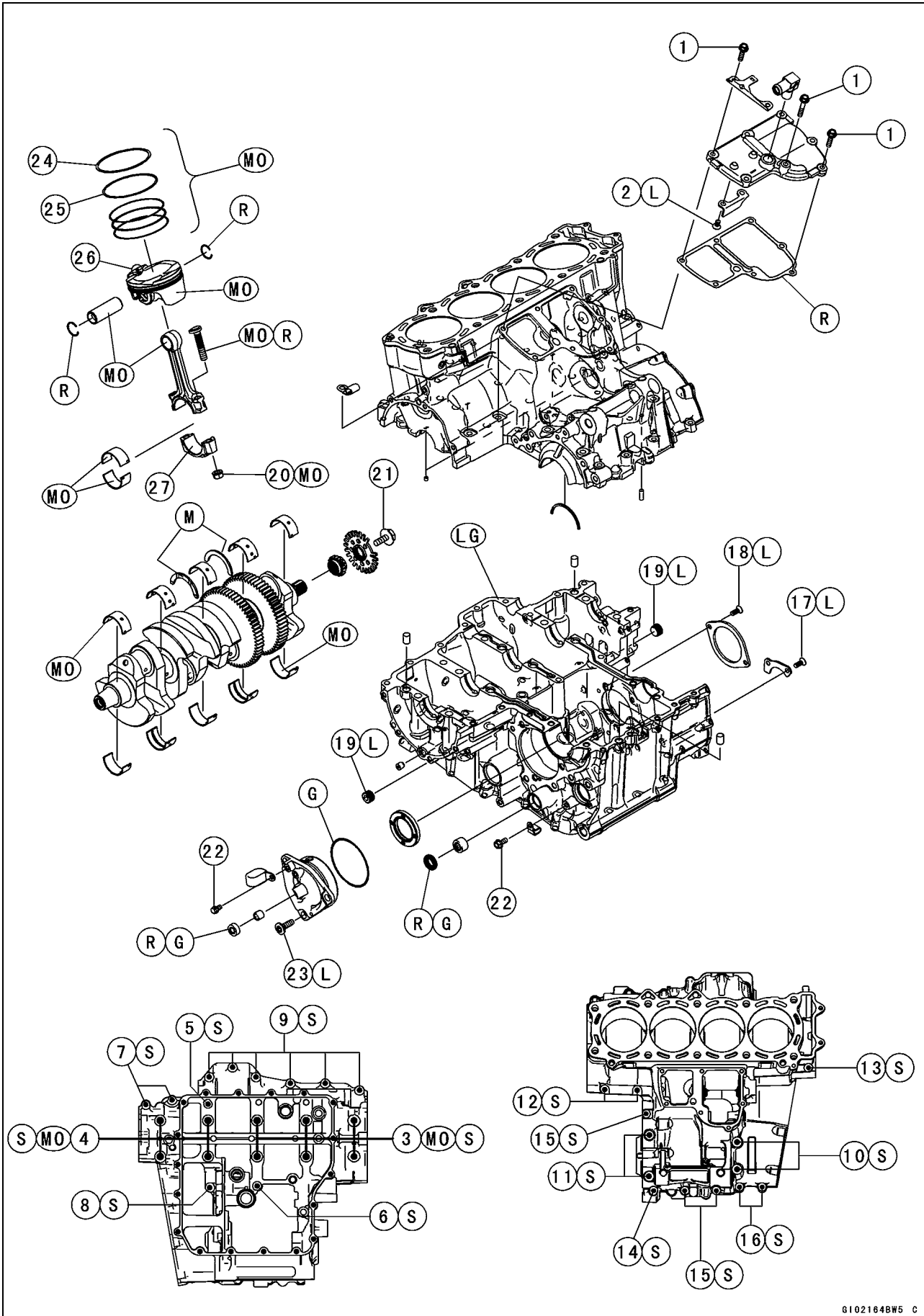

CRANKSHAFT/TRANSMISSION 9-3

Exploded View

No.	Fastener	Torque			Remarks
		N·m	kgf·m	ft·lb	
1	Breather Cover Bolts	9.8	1.0	87 in·lb	
2	Breather Plate Screws	9.8	1.0	87 in·lb	L
3	Crankcase Bolts (M10, L = 90 mm)	47	4.8	35	MO, S
4	Crankcase Bolts (M10, L = 120 mm)	47	4.8	35	MO, S
5	Crankcase Bolt (M7, L = 110 mm)	20	2.0	15	S
6	Crankcase Bolt (M7, L = 85 mm)	20	2.0	15	S
7	Crankcase Bolts (M7, L = 60 mm)	20	2.0	15	S
8	Crankcase Bolt (M7, L = 50 mm)	20	2.0	15	S
9	Crankcase Bolts (M7, L = 45 mm)	20	2.0	15	S
10	Crankcase Bolts (M8, L = 80 mm)	27	2.8	20	S
11	Crankcase Bolts (M8, L = 70 mm)	27	2.8	20	S
12	Crankcase Bolts (M7, L = 65 mm)	20	2.0	15	S
13	Crankcase Bolt (M6, L = 65 mm)	12	1.2	106 in·lb	S
14	Crankcase Bolt (M6, L = 50 mm)	12	1.2	106 in·lb	S
15	Crankcase Bolts (M6, L = 40 mm)	12	1.2	106 in·lb	S
16	Crankcase Bolts (M6, L = 25 mm)	12	1.2	106 in·lb	S
17	Shift Drum Bearing Holder Screws	4.9	0.50	43 in·lb	L
18	Bearing Position Plate Screws	4.9	0.50	43 in·lb	L
19	Oil Passage Plug	20	2.0	15	L
20	Connecting Rod Big End Nuts	see the text	←	←	←
21	Timing Rotor Bolt	39	4.0	29	
22	Gear Position Switch Lead Clamp Bolt	9.8	1.0	87 in·lb	
23	Drive Shaft Cover Bolts	25	2.5	18	L

24. "R" marked side faces up.

25. "RN" marked side faces up.

26. Hollow mark faces forward.

27. Do not apply any grease or oil.

G: Apply grease.

L: Apply a non-permanent locking agent.

LG: Apply liquid gasket (Kawasaki Bond: 92104-1064).

M: Apply molybdenum disulfide grease.

MO: Apply molybdenum disulfide oil.

(mixture of engine oil and molybdenum disulfide grease in a weight ratio is 10 : 1)

R: Replacement Parts

S: Follow the specified tightening sequence.

9-4 CRANKSHAFT/TRANSMISSION

Exploded View

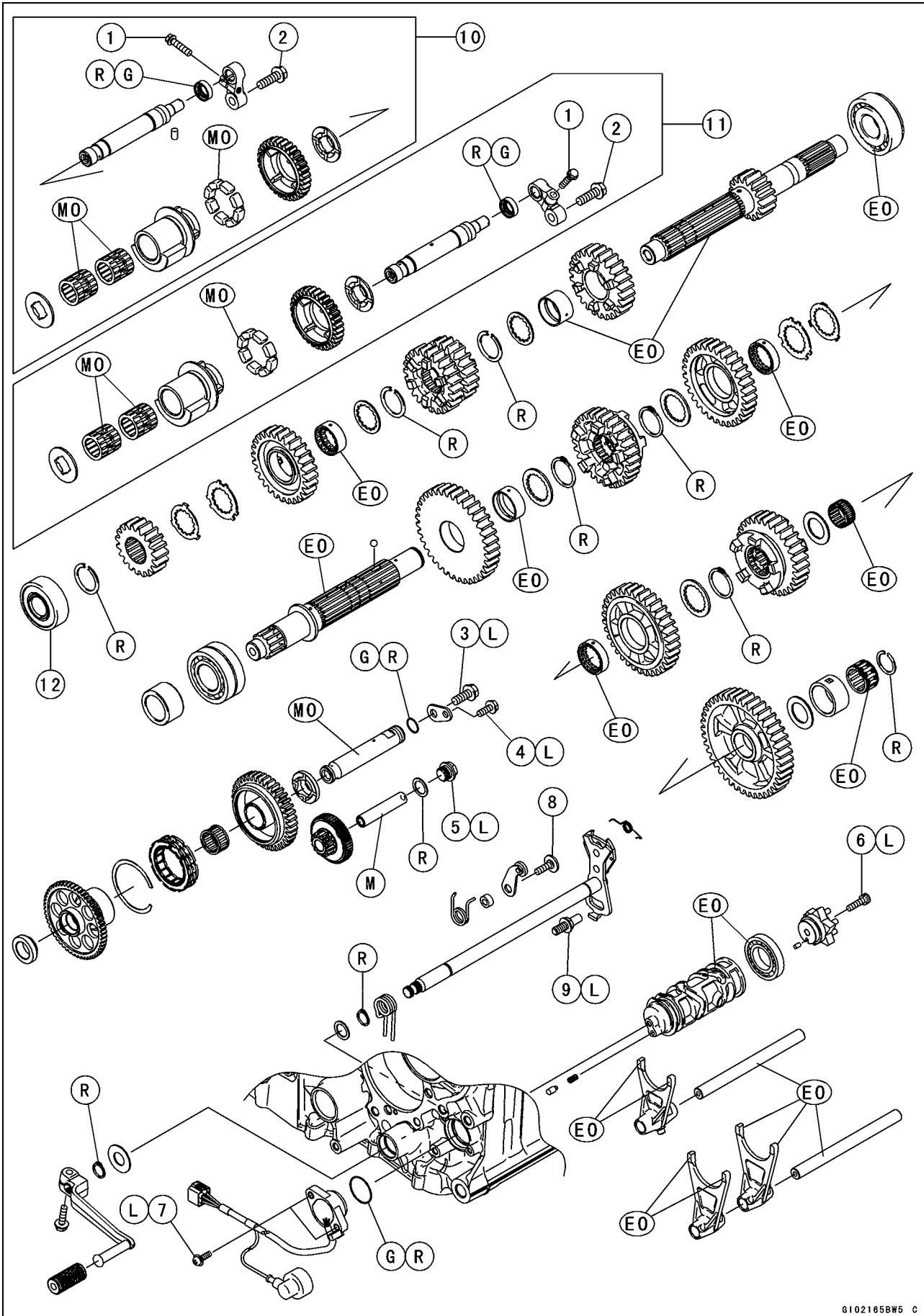

CRANKSHAFT/TRANSMISSION 9-5

Exploded View

No.	Fastener	Torque			Remarks
		N·m	kgf·m	ft·lb	
1	Balancer Shaft Clamp Bolts	9.8	1.0	87 in·lb	
2	Balancer Shaft Clamp Lever Bolts	25	2.5	18	
3	Starter Clutch Shaft Bolt	9.8	1.0	87 in·lb	L
4	Starter Clutch Shaft Plate Bolt	9.8	1.0	87 in·lb	L
5	Torque Limiter Bolt	25	2.5	18	L
6	Shift Drum Cam Holder Bolt	12	1.2	106 in·lb	L
7	Gear Position Switch Screws	2.9	0.30	26 in·lb	L
8	Gear Positioning Lever Bolt	12	1.2	106 in·lb	
9	Shift Shaft Return Spring Pin	29	3.0	21	L

10. Front Balancer

11. Rear Balancer

12. Install the bearing into the drive shaft cover so that the shield side faces in.

EO: Apply engine oil.

M: Apply molybdenum disulfide grease.

MO: Apply molybdenum disulfide oil.

(mixture of engine oil and molybdenum disulfide grease in a weight ratio is 10 : 1)

G: Apply grease.

L: Apply a non-permanent locking agent.

R: Replacement Parts

9-6 CRANKSHAFT/TRANSMISSION

Specifications

Item	Standard	Service Limit
Crankcase, Crankshaft, Connecting Rods		
Connecting Rod Bend	— — —	TIR 0.2/100 mm (0.008/3.94 in.)
Connecting Rod Twist	— — —	TIR 0.2/100 mm (0.008/3.94 in.)
Connecting Rod Big End Side Clearance	0.13 ~ 0.38 mm (0.0051 ~ 0.0150 in.)	0.58 mm (0.023 in.)
Connecting Rod Big End Bearing Insert/crankpin Clearance	0.048 ~ 0.086 mm (0.0019 ~ 0.0034 in.)	0.12 mm (0.0047 in.)
Crankpin Diameter:	37.984 ~ 38.000 mm (1.4954 ~ 1.4961 in.)	37.97 mm (1.4949 in.)
Marking	None	— — —
	○	— — —
Connecting Rod Big End Inside Diameter:	41.000 ~ 41.016 mm (1.6142 ~ 1.6148 in.)	— — —
Marking	None	— — —
	○	— — —
Connecting Rod Big End Bearing Insert Thickness:		
Brown	1.475 ~ 1.480 mm (0.05807 ~ 0.05827 in.)	— — —
Black	1.480 ~ 1.485 mm (0.05827 ~ 0.05846 in.)	— — —
Blue	1.485 ~ 1.490 mm (0.05846 ~ 0.05866 in.)	— — —
Connecting Rod Bolt Stretch:	(Usable Range)	
New Connecting Rod	0.25 ~ 0.34 mm (0.0098 ~ 0.0134 in.)	— — —
Used Connecting Rod	0.25 ~ 0.34 mm (0.0098 ~ 0.0134 in.)	— — —
Crankshaft Side Clearance	0.05 ~ 0.24 mm (0.0020 ~ 0.0094 in.)	0.30 mm (0.0118 in.)
Crankshaft Runout	TIR 0.03 mm (0.0012 in.) or less	TIR 0.08 mm (0.0031 in.)
Crankshaft Main Bearing Insert/journal Clearance	0.031 ~ 0.063 mm (0.0012 ~ 0.0025 in.)	0.09 mm (0.0035 in.)
Crankshaft Main Journal Diameter:	37.984 ~ 38.000 mm (1.4954 ~ 1.4961 in.)	37.96 mm (1.4945 in.)
Marking	None	— — —
	1	— — —
Crankcase Main Bearing Inside Diameter:	41.000 ~ 41.016 mm (1.6142 ~ 1.6148 in.)	— — —

CRANKSHAFT/TRANSMISSION 9-7

Specifications

Item	Standard	Service Limit	
Marking	○	41.000 ~ 41.008 mm (1.6142 ~ 1.6145 in.)	- - -
	None	41.009 ~ 41.016 mm (1.6145 ~ 1.6148 in.)	- - -
Crankshaft Main Bearing Insert Thickness:			
Brown	1.490 ~ 1.494 mm (0.0587 ~ 0.0588 in.)	- - -	
Black	1.494 ~ 1.498 mm (0.0588 ~ 0.0590 in.)	- - -	
Blue	1.498 ~ 1.502 mm (0.0590 ~ 0.0591 in.)	- - -	
Pistons			
Cylinder (Upper Crankcase) Inside Diameter	83.994 ~ 84.006 mm (3.3068 ~ 3.3073 in.)	84.10 mm (3.3110 in.)	
Piston Diameter	83.959 ~ 83.974 mm (3.3055 ~ 3.3061 in.)	83.81 mm (3.2996 in.)	
Piston/Cylinder Clearance	0.020 ~ 0.047 mm (0.0008 ~ 0.0019 in.)	- - -	
Piston Ring/Groove Clearance:			
Top	0.03 ~ 0.07 mm (0.0012 ~ 0.0028 in.)	0.17 mm (0.0067 in.)	
Second	0.02 ~ 0.06 mm (0.0008 ~ 0.0024 in.)	0.16 mm (0.0063 in.)	
Piston Ring Groove Width:			
Top	0.92 ~ 0.94 mm (0.0362 ~ 0.0370 in.)	1.02 mm (0.040 in.)	
Second	1.01 ~ 1.03 mm (0.0398 ~ 0.0406 in.)	1.11 mm (0.044 in.)	
Piston Ring Thickness:			
Top	0.87 ~ 0.89 mm (0.0343 ~ 0.0350 in.)	0.80 mm (0.032 in.)	
Second	0.97 ~ 0.99 mm (0.0382 ~ 0.0390 in.)	0.90 mm (0.035 in.)	
Piston Ring End Gap:			
Top	0.20 ~ 0.30 mm (0.0079 ~ 0.0118 in.)	0.6 mm (0.024 in.)	
Second	0.40 ~ 0.55 mm (0.0157 ~ 0.0217 in.)	0.8 mm (0.031 in.)	
Transmission			
Shift Fork Ear Thickness	5.74 ~ 6.00 mm (0.2260 ~ 0.2362 in.)	5.6 mm (0.220 in.)	
Gear Groove Width	6.05 ~ 6.15 mm (0.238 ~ 0.242 in.)	6.25 mm (0.246 in.)	
Shift Fork Guide Pin Diameter	6.9 ~ 7.0 mm (0.272 ~ 0.276 in.)	6.8 mm (0.268 in.)	
Shift Drum Groove Width	7.05 ~ 7.20 mm (0.278 ~ 0.283 in.)	7.3 mm (0.287 in.)	

9-8 CRANKSHAFT/TRANSMISSION

Specifications

Connecting Rod Big End Bearing Insert Selection

Con-rod Big End Bore Diameter Marking	Crankpin Diameter Marking	Bearing Insert	
		Size Color	Part Number
None	○	Brown	92139-0131
None	None	Black	92139-0130
○	○		
○	None	Blue	92139-0129

Crankshaft Main Bearing Insert Selection

Crankcase Main Bearing Inside Diameter Marking	Crankshaft Main Journal Diameter Marking	Bearing Insert		
		Size Color	Part Number	Journal Nos.
○	1	Brown	92139-0134	1, 3, 5
			92139-0137	2, 4
None	1	Black	92139-0133	1, 3, 5
○	None		92139-0136	2, 4
None	None	Blue	92139-0132	1, 3, 5
			92139-0135	2, 4

Special Tools and Sealants

Bearing Puller:
57001-135

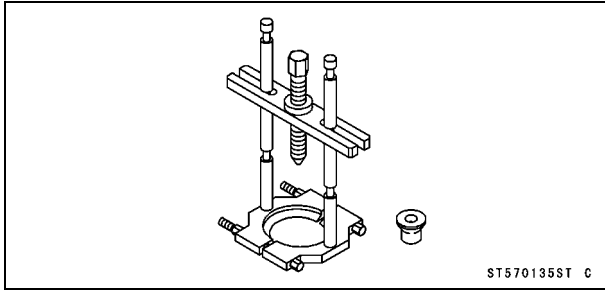

Piston Ring Compressor Belt, $\phi 80 \sim \phi 91$:
57001-1320

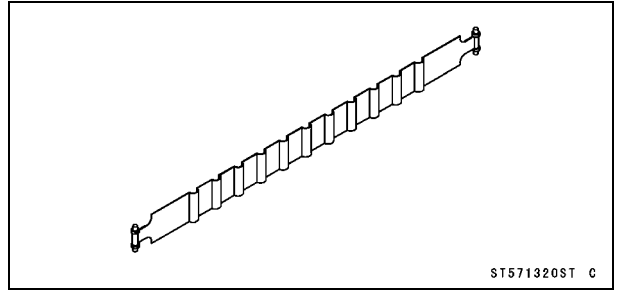

Bearing Puller Adapter:
57001-317

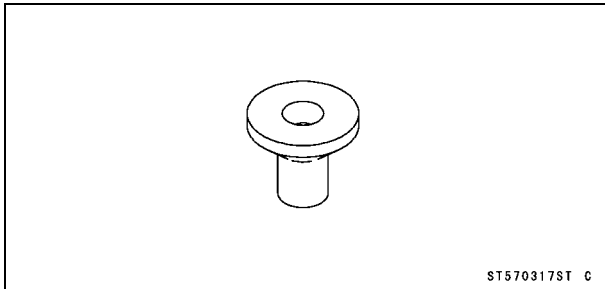

Kawasaki Bond (Silicone Sealant):
56019-120

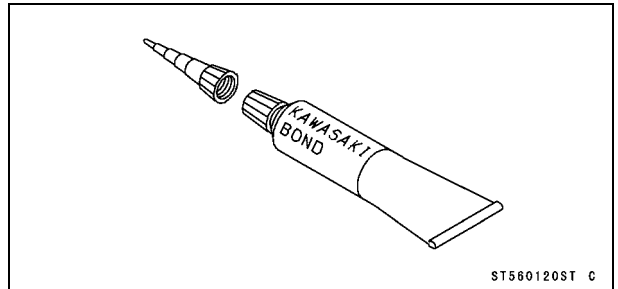

Piston Pin Puller Assembly:
57001-910

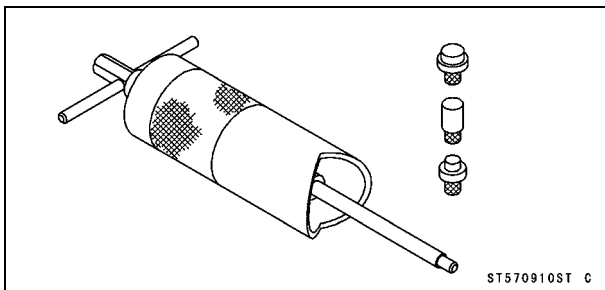

Kawasaki Bond:
92104-1064

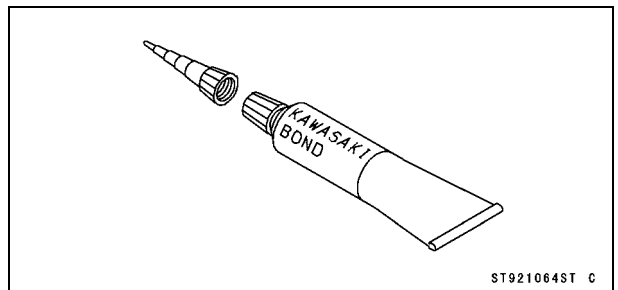

Piston Ring Compressor Grip:
57001-1095

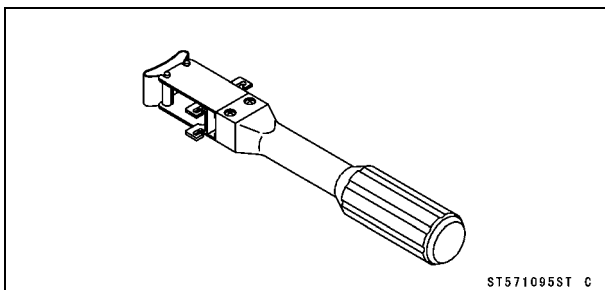

9-10 CRANKSHAFT/TRANSMISSION

Crankcase Splitting

Crankcase Splitting

- Remove the engine (see Engine Removal/Installation in the Engine Removal/Installation chapter).
- Set the engine on a clean surface and hold the engine steady while parts are being removed.
- Remove:
 - Clutch (see Clutch Removal in the Clutch chapter)
 - Starter Motor (see Starter Motor Removal in the Electrical System chapter)
 - Oil Pump (see Oil Pump Removal in the Engine Lubrication System chapter)
 - Alternator Rotor (see Alternator Rotor Removal in the Electrical System chapter)
 - Oil Cooler (see Oil Cooler Removal in the Engine Lubrication System chapter)
 - Oil Pan (see Oil Pan Removal in the Engine Lubrication System chapter)
 - External Shift Mechanism (see External Shift Mechanism Removal)
- Remove the upper crankcase bolts.
 - First loosen the M6 bolts.
 - M6 Bolts [A]
 - M7 Bolt [B]
 - M7 Bolt with Clamp [C]
 - M8 Bolts with Washers [D]

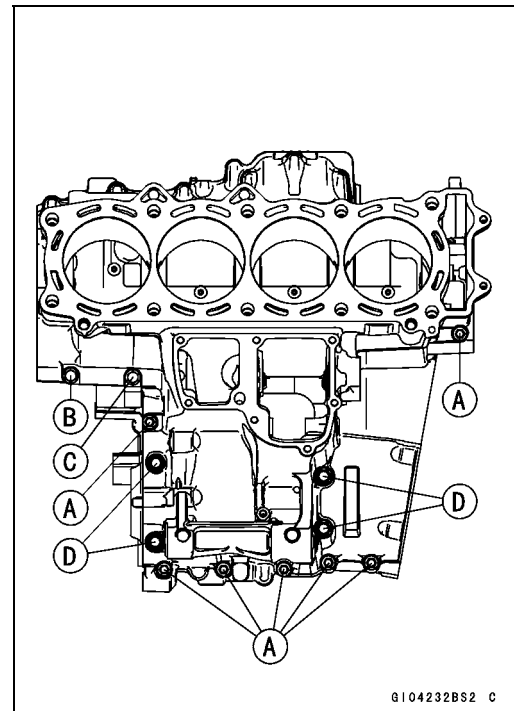

- Remove the lower crankcase bolts.
 - First loosen the M7 bolts [A].

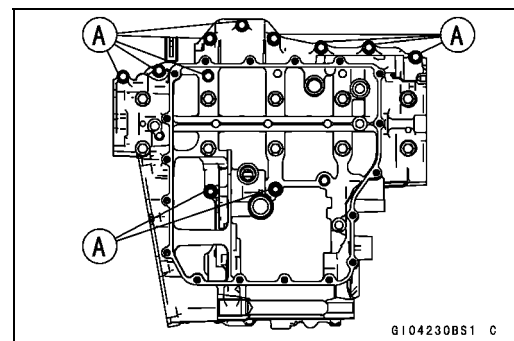

Crankcase Splitting

- Next, loosen the M10 Bolts [1~10] (sequence numbers).
- ★If the crankshaft is to be removed, remove the pistons (see Piston Removal).
- Tap lightly around the crankcase mating surface with a plastic mallet, and split the crankcase. Take care not to damage the crankcase.

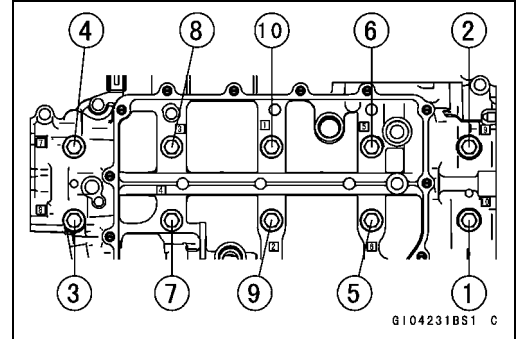

- Remove the front balancer [A] on the lower crankcase half [B] (see Front Balancer Removal).

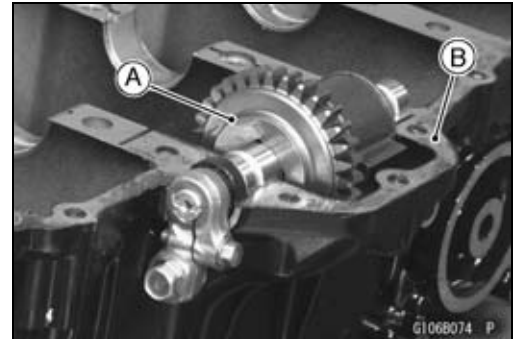

Crankcase Assembly

CAUTION

The upper and lower crankcase halves are machined at the factory in the assembled state, so the crankcase halves must be replaced as a set.

NOTE

- When replacing the crankcase halves, install the thrust washers ($t = 2.5 \text{ mm}$, 0.0984 in.) on the upper crankcase half.
- With a high-flash point solvent, clean off the mating surfaces of the crankcase halves and wipe dry.
- Using compressed air, blow out the oil passages in the crankcase halves.
- Install the new drive shaft bearing [A] so that its stepped side [B] faces as shown using a press.
- Install the bearing plate [C] with the screws [D].
- Apply a non-permanent locking agent to the bearing plate screw and tighten them.

Torque - Bearing Position Plate Screws: 4.9 N·m (0.50 kgf·m, 43 in·lb)

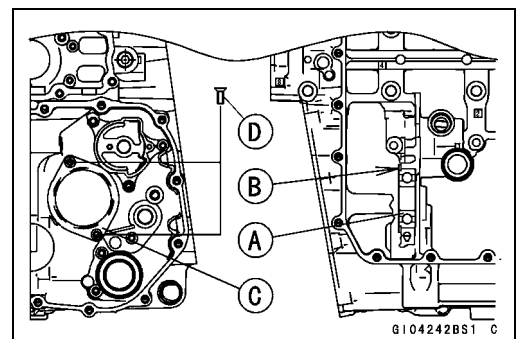

9-12 CRANKSHAFT/TRANSMISSION

Crankcase Splitting

- Install the new needle bearing [A] for the shift shaft so that its marked side [B] faces as shown, using a press.
- Install the new oil seal [C] so that its surface [D] is flush with the surface of the crankcase [E].

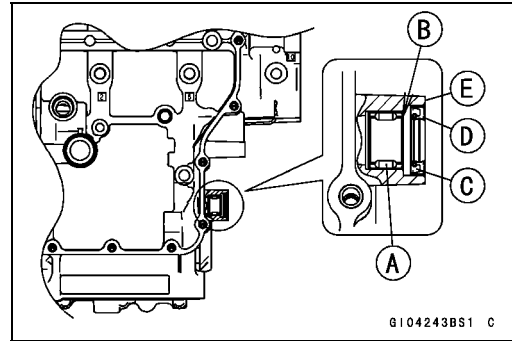

- Install:
Crankshaft, Pistons and Connecting Rods
Transmission Shaft and Gears
Dowel Pins [A]

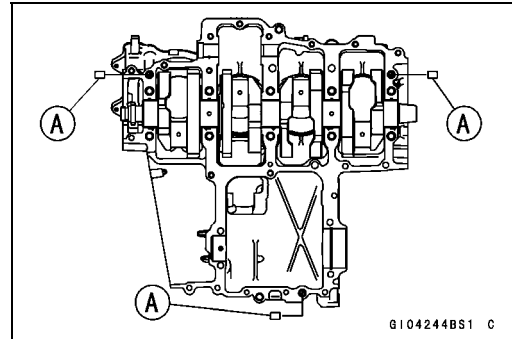

- Install the front balancer [A] on the upper crankcase half [B] (see Balancer Installation).
- Before fitting the lower case on the upper case, check the following.
 - Check to see that the shift drum and transmission gears are in the neutral position.

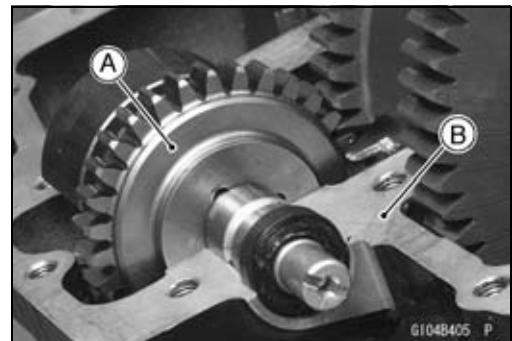

- Apply liquid gasket [A] to the mating surface of the lower crankcase half.

Sealant - Kawasaki Bond: 92104-1064

NOTE

- After tightening the crankcase bolts, wipe up the liquid gasket seeping out the output shaft bearing hole [D].
- Make the application finish within 20 minutes when the liquid gasket to the mating surface of the lower crankcase half is applied.

CAUTION

Do not apply liquid gasket to the grooves [B] inside from the crankshaft main bearing inserts, and balancer bearing.

CAUTION

Do not plug the inside of breather hole [C] with liquid gasket.

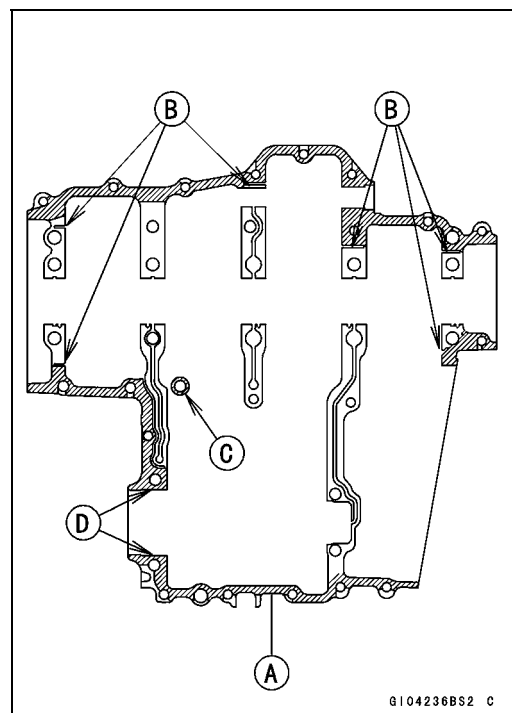

Crankcase Splitting

- Fit the lower crankcase half to the upper crankcase half.
- Be sure that the breather hole [A] on the upper crankcase [B] is not plugged with liquid gasket.

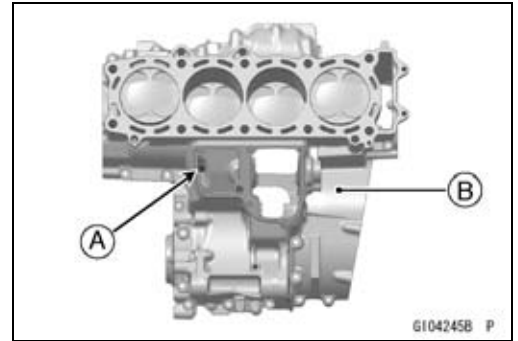

- The M10 bolts have washers, replace them with new ones.
- Apply molybdenum disulfide oil solution to the seating surfaces [A] of the washers and the threads [B] of the M10 bolts.

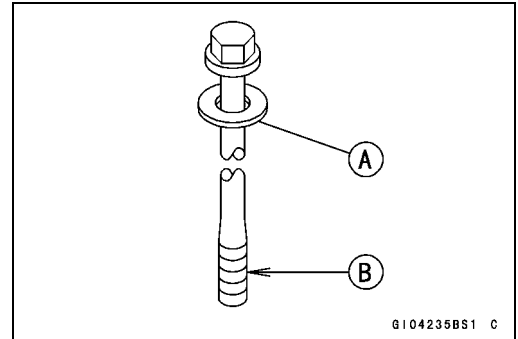

- Tighten the lower crankcase bolts using the following steps.
- Following the sequence numbers on the lower crankcase half, tighten the M10 bolts [1 ~ 10] with washers.

Torque - Crankcase Bolts (M10): 47 N·m (4.8 kgf·m, 35 ft·lb)

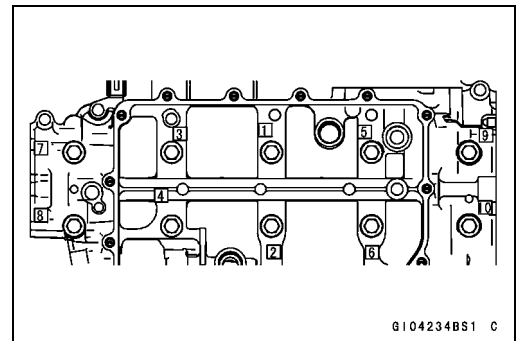

- Tighten the M7 bolts [A].

Torque - Crankcase Bolts (M7): 20 N·m (2.0 kgf·m, 15 ft·lb)

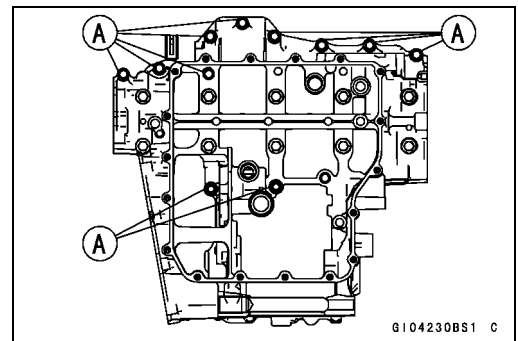

9-14 CRANKSHAFT/TRANSMISSION

Crankcase Splitting

- Tighten the upper crankcase bolts in the order listed.
- The M8 bolts have washers, replace them with new ones.
- Tighten:
 - M8 Bolts with Washers [A]
 - M7 Bolt with the clamp [B]
 - M7 Bolt [C]
 - M6 Bolts [D]

Torque - Crankcase Bolts (M8): 27 N·m (2.8 kgf·m, 20 ft·lb)

Crankcase Bolts (M7): 20 N·m (2.0 kgf·m, 15 ft·lb)

Crankcase Bolts (M6): 12 N·m (1.2 kgf·m, 106 in·lb)

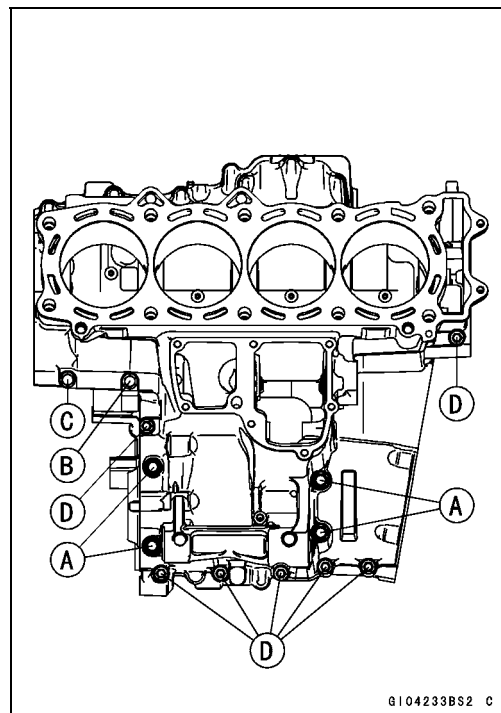

- After tightening all crankcase bolts, check the following items.
- Crankshaft and transmission shafts turn freely.
- While spinning the output shaft, gears shift smoothly from the 1st to neutral, and neutral to 1st.

Crankshaft and Connecting Rods

Crankshaft Removal

- Split the crankcase (see Crankcase Splitting).
- Remove the crankshaft (see Connecting Rod Removal).

Crankshaft Installation

CAUTION

If the crankshaft, bearing inserts, or crankcase halves are replaced with new ones, select the bearing inserts and check clearance with a plastigage (press gauge) before assembling engine to be sure the correct bearing inserts are installed.

NOTE

○When replacing the crankcase halves, install the thrust washers ($t = 2.5 \text{ mm}, 0.0984 \text{ in.}$) on the upper crankcase half.

- Apply molybdenum disulfide oil solution to the crankshaft main bearing inserts.
- Follow the next procedure to insert the thrust washers on the upper crankcase half, after installing connecting rod on the crankshaft (see Connecting Rod Installation).
- Apply molybdenum disulfide grease to the outside surfaces [A] of both thrust washers [B].
- Slide [C] one thrust washer into the upper crankcase half.
- Move the crankshaft to the left or right and then slide the other washer into the upper crankcase half.

NOTE

○Slide the thrust washers so that the oil grooves [D] face outward. Make sure that the blue-painted edges [E] are positioned as shown in figure.

Front [F]

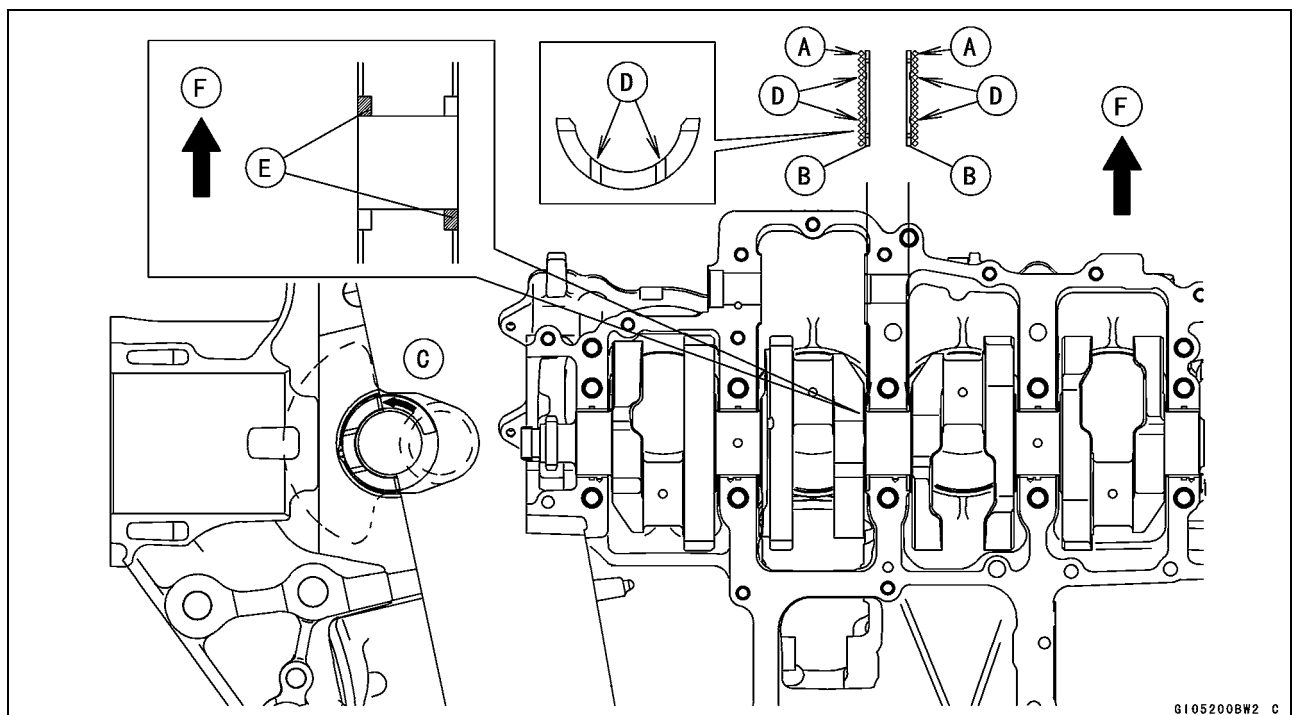

9-16 CRANKSHAFT/TRANSMISSION

Crankshaft and Connecting Rods

Connecting Rod Removal

- Split the crankcase (see Crankcase Splitting).
- Remove the connecting rod nuts [A].
- Remove the crankshaft.

NOTE

○Mark and record the locations of the connecting rods and their big end caps so that they can be reassembled in their original positions.

- Remove the piston (see Piston Removal).

CAUTION

Discard the connecting rod bolts. To prevent damage to the crankpin surfaces, do not allow the connecting rod bolts to bump against the crankpins.

Connecting Rod Installation

CAUTION

To minimize vibration, the connecting rods should have the same weight mark.

Big End Cap [A]
Connecting Rod [B]
Weight Mark, Alphabet [C]
Diameter Mark [D]: "O" or no mark

CAUTION

If the connecting rods, big end bearing inserts, or crankshaft are replaced with new ones, select the bearing insert and check clearance with a plasti-gage (press gauge) before assembling engine to be sure the correct bearing inserts are installed.

- Apply molybdenum disulfide oil to the inner surface of the upper and lower bearing inserts [A].
- Apply molybdenum disulfide oil to the threads [B] and seating surface [C] of the connecting rod nuts.
- Install the inserts so that their nails [D] are on the same side and fit them into the recess of the connecting rod and cap.

CAUTION

Wrong application of oil and grease could cause bearing damage.

○When installing the inserts [A], be careful not to damage the insert surface with the edge of the connecting rod [B] or the cap [C]. One way to install inserts is as follows.

Installation [D] to Cap
Installation [E] to Connecting Rod
Push [F]
Spare Dowel Pin [G]
Connecting Rod Bolts [H]

- Remove debris and clean the surface of inserts.
- Install the cap on the connecting rod, aligning the weight and diameter marks.

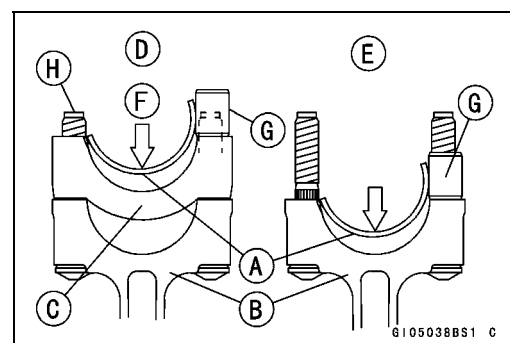
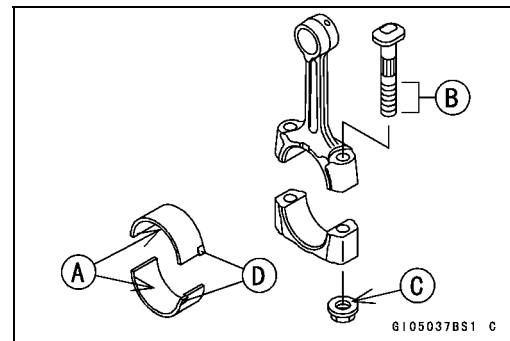
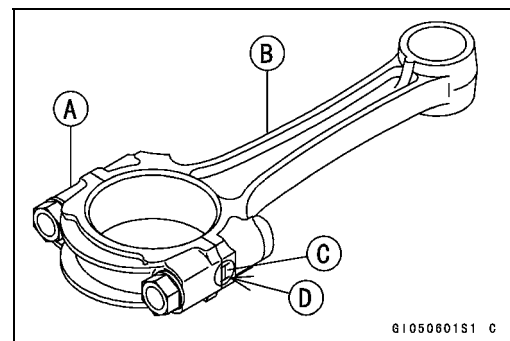
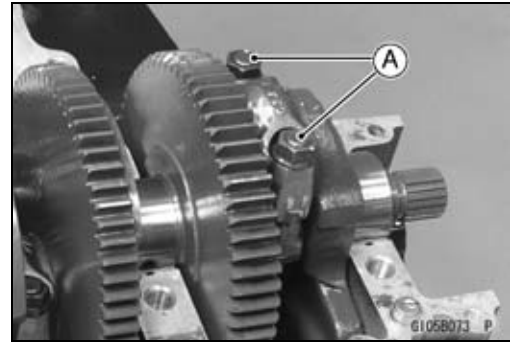

Crankshaft and Connecting Rods

- Install the crankshaft (see Crankshaft Installation).
- Install each connecting rod on its original crankpin.
- The connecting rod big end is bolted using the “plastic region fastening method”.
- This method precisely achieves the needed clamping force without exceeding it unnecessarily, allowing the use of thinner, lighter bolts further decreasing connecting rod weight.
- There are two types of the plastic region fastening. One is a bolt length measurement method and other is a rotation angle method. Observe one of the following two, but the bolt length measurement method is preferable because this is a more reliable way to tighten the big end nuts.

CAUTION
The connecting rod bolts are designed to stretch when tightened. Never reuse the connecting rod bolts. See the table below for correct bolt and nut usage.

CAUTION
Be careful not to overtighten the nuts. The bolts must be positioned on the seating surface correctly to prevent the bolt heads from hitting the crankcase.

(1) Bolt Length Measurement Method

- Be sure to clean the bolts, nuts, and connecting rods thoroughly with a high-flash point solvent, because the new connecting rods, bolts, and nuts are treated with an anti-rust solution.

⚠ WARNING
Clean the bolts, nuts, and connecting rods in a well-ventilated area, and take care that there is no spark or flame anywhere near the working area. This includes any appliance with a pilot light. Because of the danger of highly flammable liquids, do not use gasoline or low-flash point solvents to clean them.

CAUTION
Immediately dry the bolts and nuts with compressed air after cleaning. Clean and dry the bolts and nuts completely.

9-18 CRANKSHAFT/TRANSMISSION

Crankshaft and Connecting Rods

- Install new bolts in reused connecting rods.
- Dent both bolt head and bolt tip with a punch as shown.
- Before tightening, use a point micrometer to measure the length of new connecting rod bolts and record the values to find the bolt stretch.

Connecting Rod [A]

Dent here with a punch [B].

Nuts [C]

Fit micrometer pins into dents [D].

- Apply a small amount of molybdenum disulfide oil to the following.

Threads of Nuts and Bolts

Seating Surfaces of Nuts and Connecting rods

- Tighten the big end nuts until the bolt elongation reaches the length specified in the table.
- Check the length of the connecting rod bolts.
- ★ If the stretch is more than the usable range, the bolt has stretched too much. An overelongated bolt may break in use.

$$\text{Bolt Length after tightening} - \text{Bolt Length before tightening} = \text{Bolt Stretch}$$

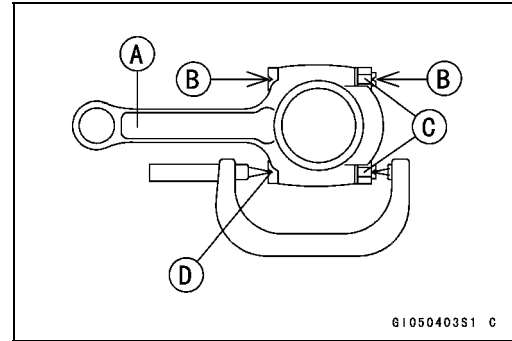

Connect- ing Rod Assy	Bolt	Nut	Usable Range of Connecting Rod Bolt Stretch
New	Use the bolts attached to new con-rod.	Attached to new con-rod	0.25 ~ 0.34 mm (0.0098 ~ 0.0134 in.)
		New	
Used	Replace the bolts with new ones.	Used	0.25 ~ 0.34 mm (0.0098 ~ 0.0134 in.)
		New	

(2) Rotation Angle Method

- ★ If you don't have a point micrometer, you may tighten the nuts using the "Rotation Angle Method".
- Be sure to clean the bolts, nuts and connecting rods thoroughly with a high-flash point solvent, because the new connecting rods, bolts and nuts are treated with an anti-rust solution.

⚠ WARNING

Clean the bolts, nuts and connecting rods in a well-ventilated area, and take care that there is no spark or flame anywhere near the working area. This includes any appliance with a pilot light. Because of the danger or highly flammable liquids, do not use gasoline or low-flash point solvents to clean them.

CAUTION

**Immediately dry the bolts and nuts with compressed air after cleaning.
Clean and dry the bolts and nuts completely.**

Crankshaft and Connecting Rods

- Install new bolts in reused connecting rods.
- Apply a small amount of molybdenum disulfide oil to the following.
 - Threads [A] of Nuts and Bolts
 - Seating Surfaces [B] of Nuts and Connecting Rods

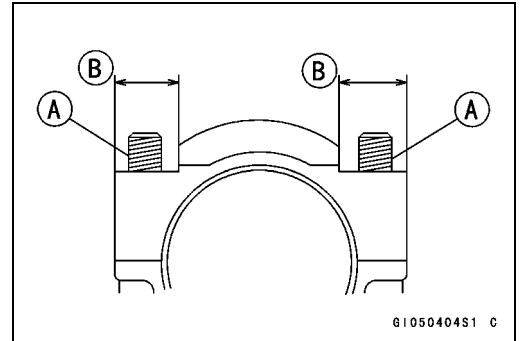

- First, tighten the nuts to the specified torque. See the table below.
 - Next, tighten the nuts $120^\circ \pm 5^\circ$.
- Mark [A] the connecting rod big end caps and nuts so that nuts can be turned 120° [B] properly.

Connecting Rod Assy	Bolt	Nut	Torque + Angle N·m (kgf·m, ft·lb)
New	Use the bolts attached to new con-rod.	Attached to new con-rod	21.6 (2.2, 16) + 120°
		New	21.6 (2.2, 16) + 120°
Used	Replace the bolts with new ones	Used	21.6 (2.2, 16) + 120°
		New	21.6 (2.2, 16) + 120°

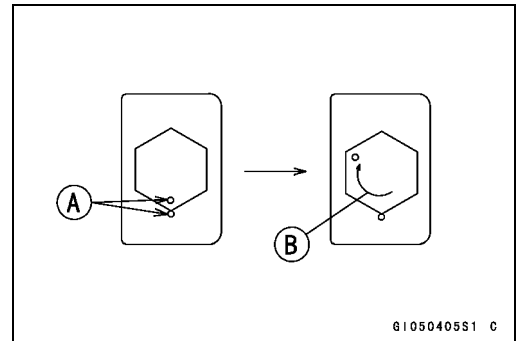

Crankshaft/Connecting Rod Cleaning

- After removing the connecting rods from the crankshaft, clean them with a high-flash point solvent.
- Blow the crankshaft oil passages with compressed air to remove any foreign particles or residue that may have accumulated in the passages.

Connecting Rod Bend

- Remove the connecting rod big end bearing inserts, and reinstall the connecting rod big end cap.
 - Select an arbor [A] of the same diameter as the connecting rod big end, and insert the arbor through the connecting rod big end.
 - Select an arbor of the same diameter as the piston pin and at least 100 mm (3.94 in.) long, and insert the arbor [B] through the connecting rod small end.
 - On a surface plate, set the big-end arbor on V block [C].
 - With the connecting rod held vertically, use a height gauge to measure the difference in the height of the arbor above the surface plate over a 100 mm (3.94 in.) length to determine the amount of connecting rod bend.
- ★ If connecting rod bend exceeds the service limit, the connecting rod must be replaced.

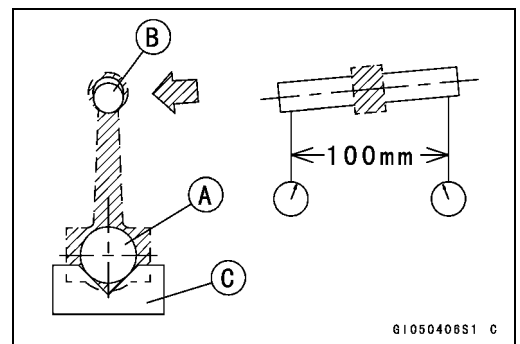

Connecting Rod Bend

Service Limit: TIR 0.2/100 mm (0.008/3.94 in.)

9-20 CRANKSHAFT/TRANSMISSION

Crankshaft and Connecting Rods

Connecting Rod Twist

- With the big-end arbor [A] still on V block [C], hold the connecting rod horizontally and measure the amount that the arbor [B] varies from being paralleled with the surface plate over a 100 mm (3.94 in.) length of the arbor to determine the amount of connecting rod twist.
- ★ If connecting rod twist exceeds the service limit, the connecting rod must be replaced.

Connecting Rod Twist

Service Limit: TIR 0.2/100 mm (0.008/3.94 in.)

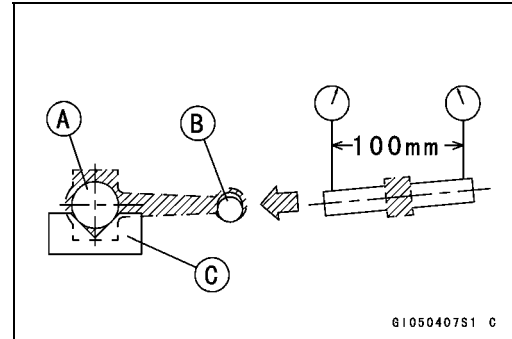

Connecting Rod Big End Side Clearance

- Measure connecting rod big end side clearance.
- Insert a thickness gauge [A] between the big end and either crank web to determine clearance.

Connecting Rod Big End Side Clearance

Standard: 0.13 ~ 0.38 mm (0.0051 ~ 0.0150 in.)

Service Limit: 0.58 mm (0.023 in.)

- ★ If the clearance exceeds the service limit, replace the connecting rod with new one and then check clearance again. If clearance is too large after connecting rod replacement, the crankshaft also must be replaced.



Connecting Rod Big End Bearing Insert/Crankpin Wear

- Measure the bearing insert/crankpin [B] clearance with plastigage [A].
- Tighten the big end nuts to the specified torque (see Connecting Rod Installation).

NOTE

- Do not move the connecting rod and crankshaft during clearance measurement.

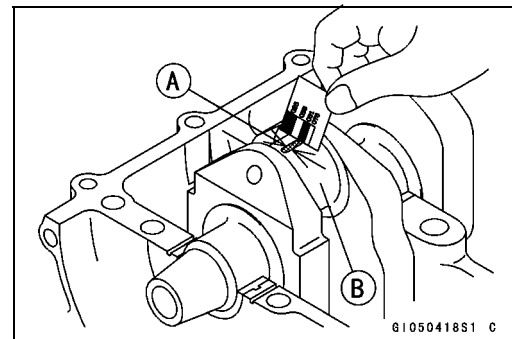

CAUTION

After measurement, replace the connecting rod bolts.

Connecting Rod Big End Bearing Insert/Crankpin Clearance

Standard: 0.048 ~ 0.086 mm (0.0019 ~ 0.0034 in.)

Service Limit: 0.12 mm (0.0047 in.)

Crankshaft and Connecting Rods

- ★ If the clearance is within the standard, no bearing replacement is required.
- ★ If the clearance is between 0.087 mm (0.0034 in.) and the service limit (0.12 mm, 0.0047 in.), replace the bearing inserts [A] with inserts painted blue [B]. Check insert/crankpin clearance with the plastigage. The clearance may exceed the standard slightly, but it must not be less than the minimum in order to avoid bearing seizure.
- ★ If the clearance exceeds the service limit, measure the diameter of the crankpins.

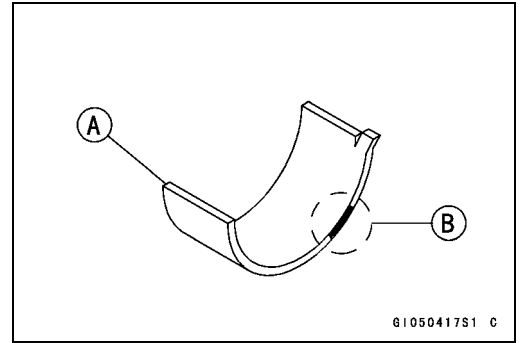

Crankpin Diameter

Standard: 37.984 ~ 38.000 mm (1.4954 ~ 1.4961 in.)
Service Limit: 37.97 mm (1.4949 in.)

- ★ If any crankpin has worn past the service limit, replace the crankshaft with a new one.
- ★ If the measured crankpin diameters are not less than the service limit, but do not coincide with the original diameter markings on the crankshaft, make new marks on it.

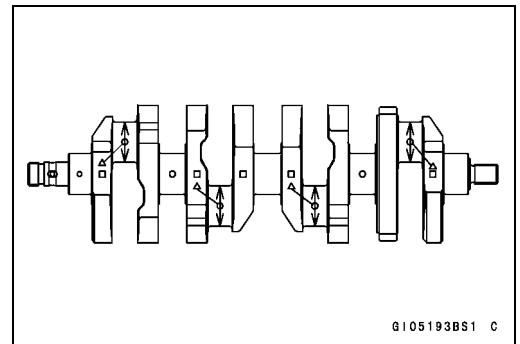

Crankpin Diameter Marks

None 37.984 ~ 37.992 mm (1.4954 ~ 1.4957 in.)
 ○ 37.993 ~ 38.000 mm (1.4958 ~ 1.4961 in.)

△: Crankpin Diameter Marks, "○" or no mark.

- Measure the connecting rod big end inside diameter, and mark each connecting rod big end in accordance with the inside diameter.
- Tighten the connecting rod big end nuts to the specified torque (see Connecting Rod Installation).

NOTE

○ *The mark already on the big end should almost coincide with the measurement.*

Connecting Rod Big End Inside Diameter Marks

None 41.000 ~ 41.008 mm (1.6142 ~ 1.6145 in.)
 ○ 41.009 ~ 41.016 mm (1.6145 ~ 1.6148 in.)

Big End Cap [A]
 Connecting Rod [B]
 Weight Mark, Alphabet [C]
 Diameter Mark (Around Weight Mark) [D]: "○" or no mark

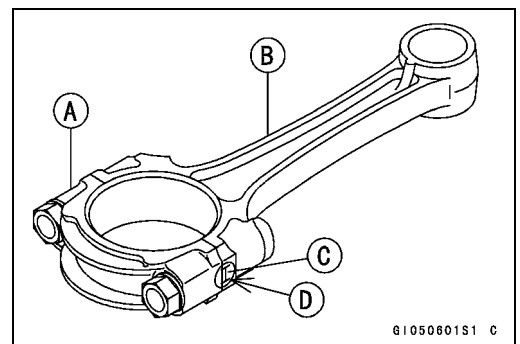

9-22 CRANKSHAFT/TRANSMISSION

Crankshaft and Connecting Rods

- Select the proper bearing insert [A] in accordance with the combination of the connecting rod and crankshaft coding.
Size Color [B]

Con-rod Big End Inside Diameter Marking	Crankpin Diameter Marking	Bearing Insert	
		Size Color	Part Number
None	○	Brown	92139-0131
None	None	Black	92139-0130
○	○		
○	None	Blue	92139-0129

- Install the new inserts in the connecting rod and check insert/crankpin clearance with the plastigage.

Crankshaft Side Clearance

- Move [A] the crankshaft to the side of the camshaft chain.
- Insert a thickness gauge [B] between the thrust washer [C] and the crank web [D] at the No. 3 main journal to determine clearance.

Crankshaft Side Clearance

Standard: 0.05 ~ 0.24 mm (0.0020 ~ 0.0094 in.)
Service Limit: 0.30 mm (0.0118 in.)

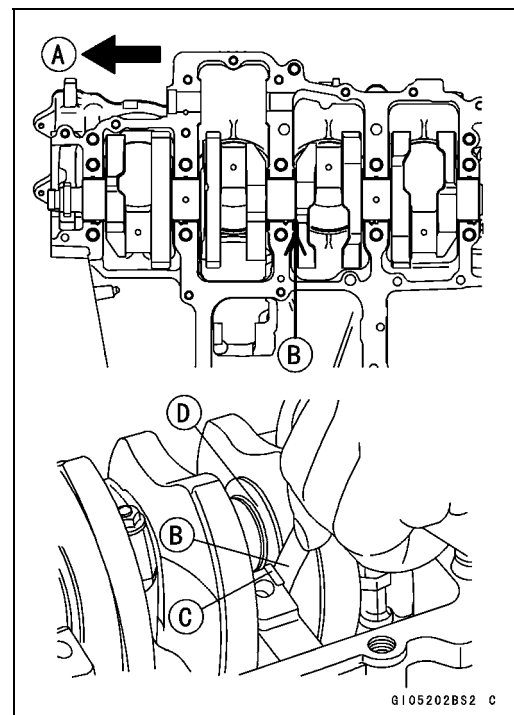
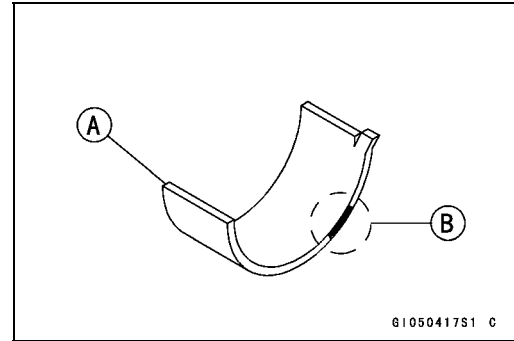

- ★ If the clearance exceeds the service limit, replace the thrust washer as a set.
- Measure the width [A] of the both thrust washers.
- ★ If the thrust washers (t = 2.5 mm, 0.0984 in.) are installed on the upper crankcase half, replace them with new thrust washer (t = 2.5 mm, 0.0984 in.) as a set.

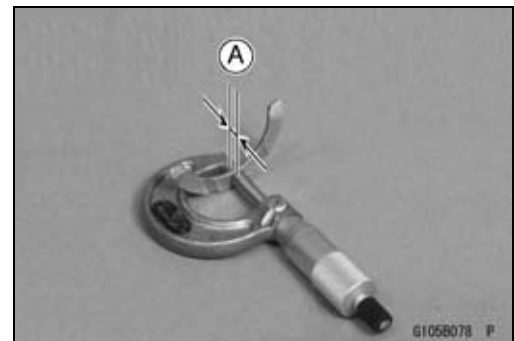

Crankshaft and Connecting Rods

★ If the thrust washers (t = 4.0 mm, 0.1575 in.) are installed on the upper crankcase half, replace them with new thrust washer (t = 4.0 mm, 0.1575 in.) as a set.

Thrust Washer P/No.	Thickness	Edge Color
92200-0331	2.45 ~ 2.50 mm (0.0965 ~ 0.0984 in.)	Blue
92200-0332	3.95 ~ 4.00 mm (0.1555 ~ 0.1575 in.)	Blue

NOTE

○ For the crankcase, only crankcase set (P/No. 14001-0089) be available as spare parts.

- Check the width of the crankshaft #3 main journal.
- Measure the crankshaft #3 main journal width [A].
- ★ If the measurement exceeds the standard, replace the crankshaft [B].

Crankshaft #3 Main Journal Width

Standard: 27.45 ~ 27.50 mm (1.0807 ~ 1.0827 in.)

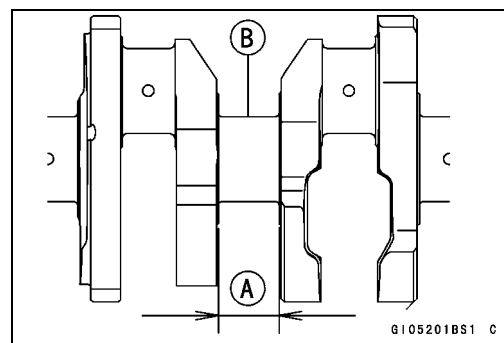

Crankshaft Runout

- Measure the crankshaft runout.
- ★ If the measurement exceeds the service limit, replace the crankshaft.

Crankshaft Runout

Standard: TIR 0.03 mm (0.0012 in.) or less

Service Limit: TIR 0.08 mm (0.0031 in.)

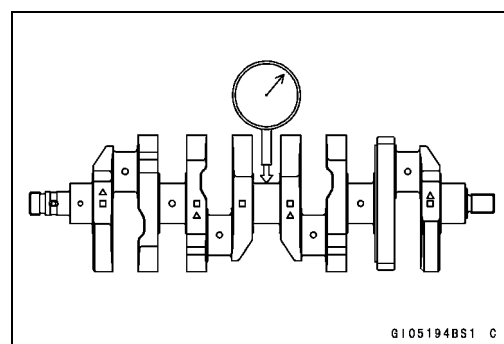

Crankshaft Main Bearing Insert/Journal Wear

- Using a plastigage (press gauge) [A], measure the bearing insert/journal [B] clearance.

NOTE

- Tighten the crankcase bolts to the specified torque (see Crankcase Assembly).
- Do not turn the crankshaft during clearance measurement.
- Journal clearance less than 0.025 mm (0.00098 in.) can not be measured by plastigage, however, using genuine parts maintains the minimum standard clearance.

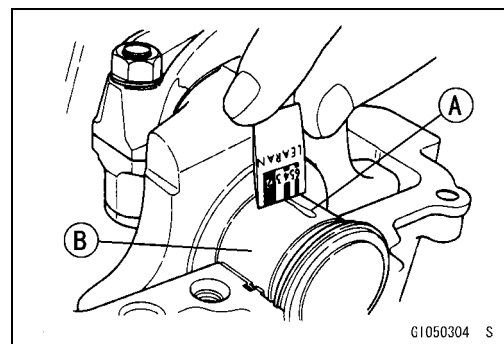

9-24 CRANKSHAFT/TRANSMISSION

Crankshaft and Connecting Rods

Crankshaft Main Bearing Insert/Journal Clearance

Standard: 0.031 ~ 0.063 mm (0.0012 ~ 0.0025 in.)

Service Limit: 0.09 mm (0.0035 in.)

- ★ If the clearance is within the standard, no bearing replacement is required.
- ★ If the clearance is between 0.064 mm (0.0025 in.) and the service limit (0.09 mm, 0.0035 in.), replace the bearing inserts [A] with inserts painted blue [B]. Check insert/journal clearance with the plastigage. The clearance may exceed the standard slightly, but it must not be less than the minimum in order to avoid bearing seizure.
- ★ If the clearance exceeds the service limit, measure the diameter of the crankshaft main journal.

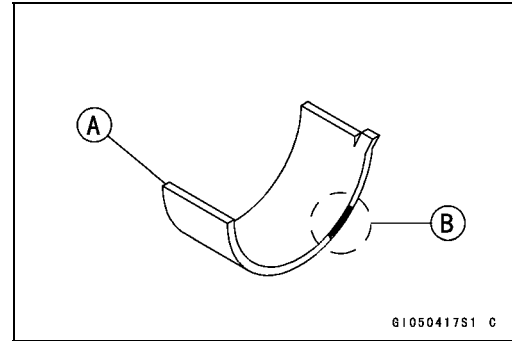

Crankshaft Main Journal Diameter

Standard: 37.984 ~ 38.000 mm (1.4954 ~ 1.4961 in.)

Service Limit: 37.96 mm (1.4945 in.)

- ★ If any journal has worn past the service limit, replace the crankshaft with a new one.
- ★ If the measured journal diameters are not less than the service limit, but do not coincide with the original diameter markings on the crankshaft, make new marks on it.

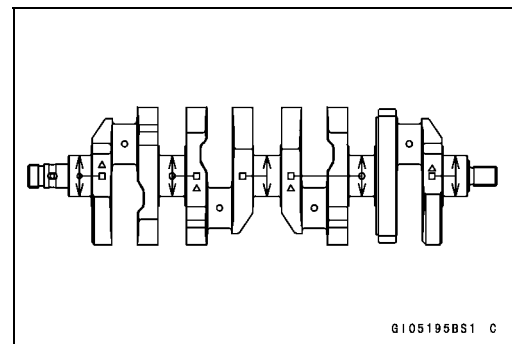

Crankshaft Main Journal Diameter Marks

None 37.984 ~ 37.992 mm (1.4954 ~ 1.4957 in.)

1 37.993 ~ 38.000 mm (1.4958 ~ 1.4961 in.)

□: Crankshaft Main Journal Diameter Marks, "1" or no mark.

- Measure the main bearing inside diameter, and mark the upper crankcase half in accordance with the inside diameter.
 - A: Crankcase Main Bearing Inside Diameter Marks, "○" mark or no mark.
- Tighten the crankcase bolts to the specified torque (see Crankcase Assembly).

NOTE

○ The mark already on the upper crankcase half should almost coincide with the measurement.

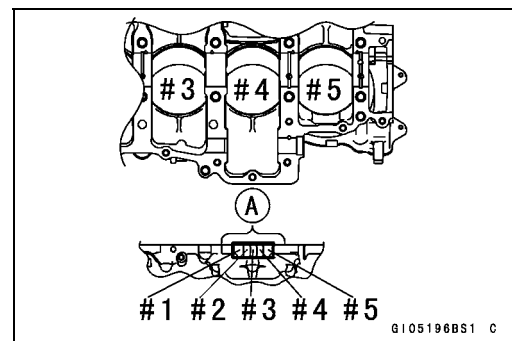

Crankcase Main Bearing Inside Diameter Marks

○ 41.000 ~ 41.008 mm (1.6142 ~ 1.6145 in.)

None 41.009 ~ 41.016 mm (1.6145 ~ 1.6148 in.)

- Select the proper bearing insert [A] in accordance with the combination of the crankcase and crankshaft coding.
 - Size Color [B]

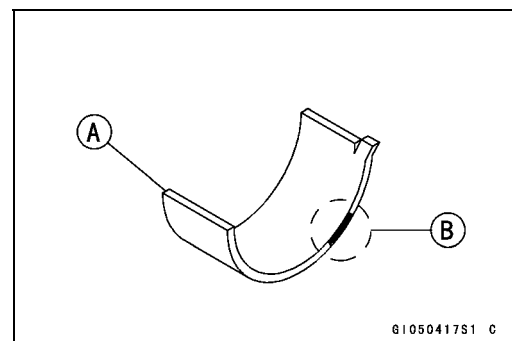

Crankshaft and Connecting Rods

Crankcase Main Bearing Inside Diameter Marking	Crankshaft Main Journal Diameter Marking	Bearing Insert		
		Size Color	Part Number	Journal Nos.
○	1	Brown	92139-0134	1, 3, 5
			92139-0137	2, 4
None	1	Black	92139-0133	1, 3, 5
○	None		92139-0136	2, 4
None	None	Blue	92139-0132	1, 3, 5
			92139-0135	2, 4

- Install the new inserts in the crankcase halves and check insert/journal clearance with the plastigage.

9-26 CRANKSHAFT/TRANSMISSION

Pistons

Piston Removal

- Split the crankcase (see Crankcase Splitting).
- Remove the connecting rod nuts [A].
- Remove the connecting rod big end caps.

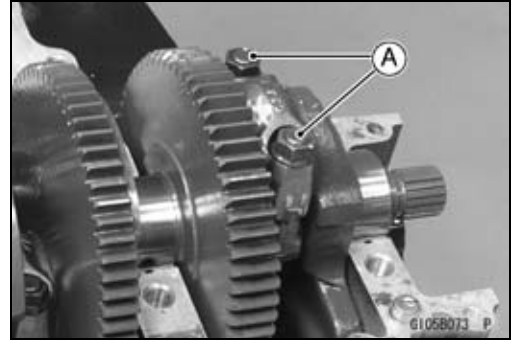

- Remove the crankshaft.
- Remove the piston to the cylinder head side.

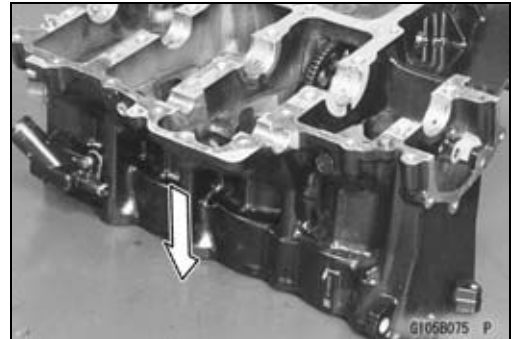

- Remove the piston pin snap ring [A].



- Remove the piston pins.
Special Tool - Piston Pin Puller Assembly [A]: 57001-910
- Remove the pistons.

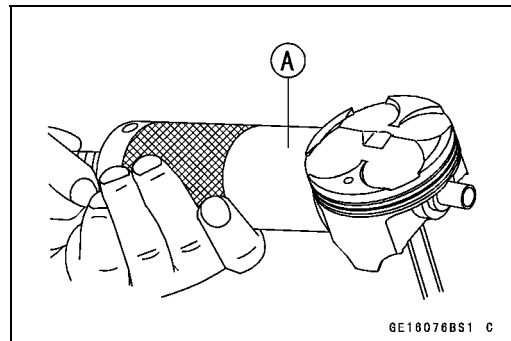

- Carefully spread the ring opening with your thumbs and then push up on the opposite side of the ring [A] to remove it.
- Remove the 3-piece oil ring with your thumbs in the same manner.

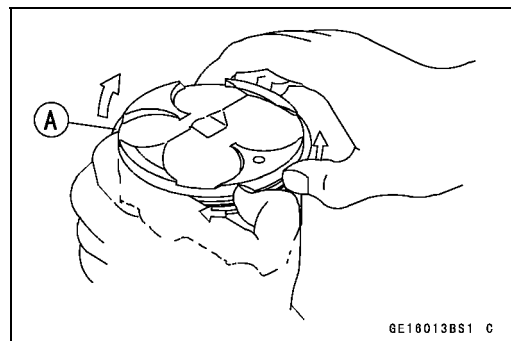

Pistons

Piston Installation

- Apply molybdenum disulfide oil solution to the oil ring expander, and install the oil ring expander [A] in the bottom piston ring groove so the ends [B] butt together.
- Apply molybdenum disulfide oil solution to the oil ring steel rails, and install the oil ring steel rails, one above the expander and one below it.
- Spread the rail with your thumbs, but only enough to fit the rail over the piston.
- Release the rail into the bottom piston ring groove.

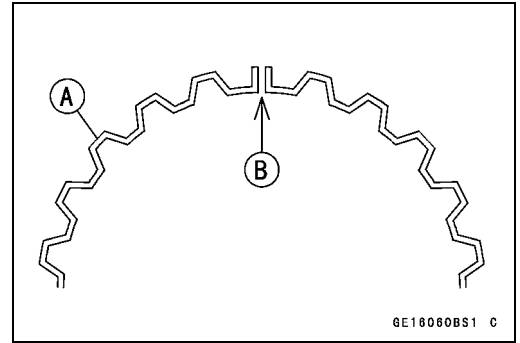

NOTE

○The oil ring rails have no "top" or "bottom".

- Do not mix up the top and second ring.
- Install the top ring [A] so that the "R" mark [B] faces up.
- Install the second ring [C] so that the "RN" mark [D] faces up.
- Apply molybdenum disulfide oil solution to the piston rings.

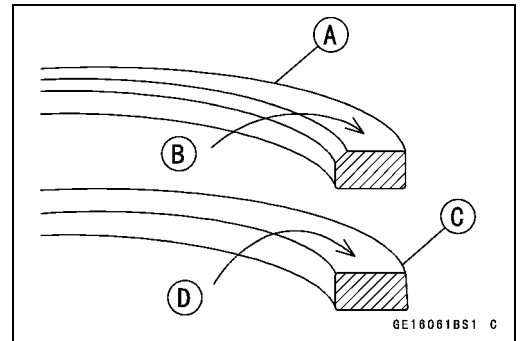

NOTE

○If a new piston is used, use new piston ring.

- Fit a new piston pin snap ring into the side of the piston so that the ring opening [A] does not coincide with the slit [B] of the piston pin hole.
- Apply molybdenum disulfide oil solution to the piston pins and piston journals.
- When installing the piston pin snap ring, compress it only enough to install it and no more.

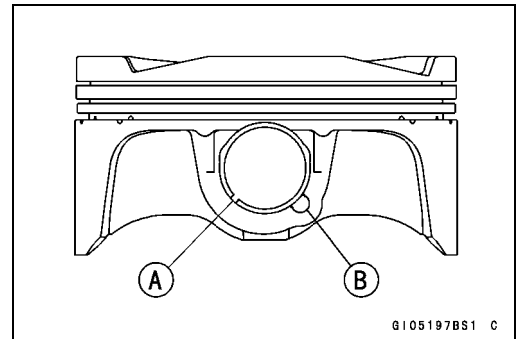

CAUTION

Do not reuse snap rings, as removal weakens and deforms them. They could fall out and score the cylinder wall.

- The piston ring openings must be positioned as shown in the figure. The openings of the oil ring steel rails must be about 30-40° of angle from the opening of the top ring.
 - Top Ring [A]
 - Second Ring [B]
 - Oil Ring Steel Rails [C]
 - Oil Ring Expander [D]
 - Hollow [E]
 - 30 ~ 40° [F]

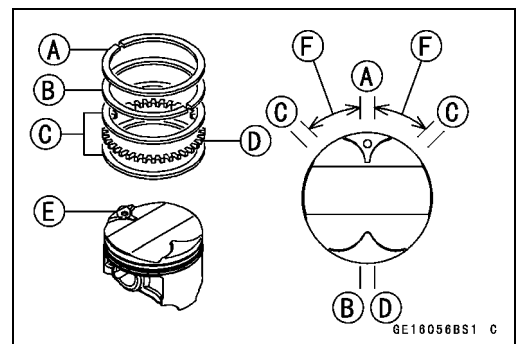

9-28 CRANKSHAFT/TRANSMISSION

Pistons

- Install the piston with its marking hollow facing exhaust side.
- Using the piston ring compressor assy [A] to install the piston from the cylinder head side.

Special Tools - Piston Ring Compressor Grip: 57001-1095
Piston Ring Compressor Belt, $\phi 80 \sim \phi 91$: 57001-1320

- Install the crankshaft.
- Install the connecting rod to the crankshaft (see Connecting Rod Installation).

Cylinder Wear (Upper Crankcase)

- Since there is a difference in cylinder wear (upper crankcase) in different directions, take a side-to-side and a front-to-back measurement at each of the two locations (total of four measurements) shown in the figure.

- ★ If any of the cylinder inside diameter measurements exceeds the service limit, replace the crankcase.

10 mm (0.39 in.) [A]

60 mm (2.36 in.) [B]

Cylinder Inside Diameter

Standard: 83.994 ~ 84.006 mm (3.3068 ~ 3.3073 in.)

Service Limit: 84.10 mm (3.3110 in.)

Piston Wear

- Measure the outside diameter [A] of each piston 10 mm (0.39 in.) [B] up from the bottom of the piston at a right angle to the direction of the piston pin.

- ★ If the measurement is under service limit, replace the piston.

Piston Diameter

Standard: 83.959 ~ 83.974 mm (3.3055 ~ 3.3061 in.)

Service Limit: 83.81 mm (3.2996 in.)

Piston Ring, Piston Ring Groove Wear

- Check for uneven groove wear by inspecting the ring seating.

- ★ The rings should fit perfectly parallel to groove surfaces. If not, replace the piston and all the piston rings.

- With the piston rings in their grooves, make several measurements with a thickness gauge [A] to determine piston ring/groove clearance.

Piston Ring/Groove Clearance

Standard:

Top 0.03 ~ 0.07 mm (0.0012 ~ 0.0028 in.)

Second 0.02 ~ 0.06 mm (0.0008 ~ 0.0024 in.)

Service Limit:

Top 0.17 mm (0.0067 in.)

Second 0.16 mm (0.0063 in.)

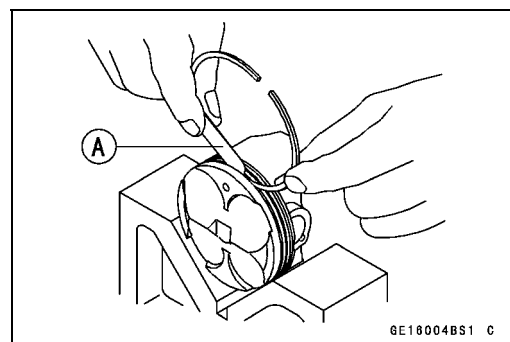
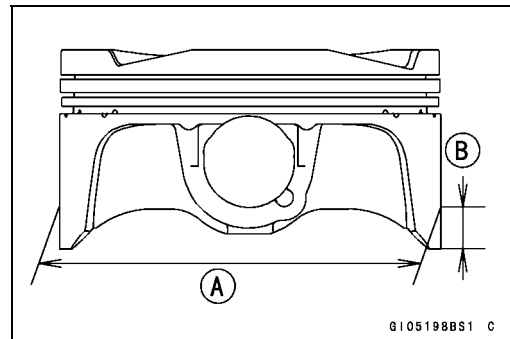
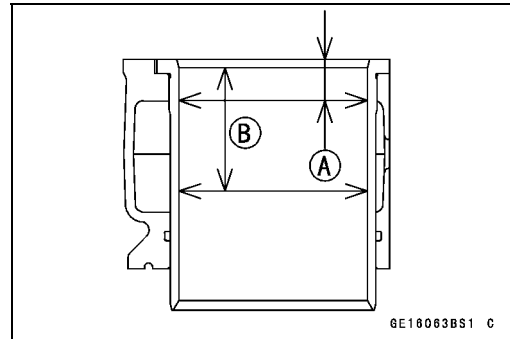
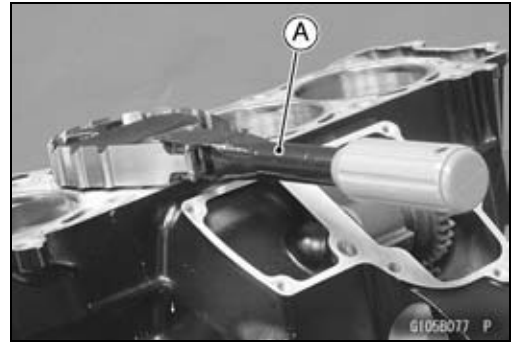

Pistons

Piston Ring Groove Width

- Measure the piston ring groove width.
- Use a vernier caliper at several points around the piston.

Piston Ring Groove Width

Standard:

- Top [A] 0.92 ~ 0.94 mm (0.0362 ~ 0.0370 in.)
- Second [B] 1.01 ~ 1.03 mm (0.0398 ~ 0.0406 in.)

Service Limit:

- Top [A] 1.02 mm (0.040 in.)
- Second [B] 1.11 mm (0.044 in.)

- ★ If the width of any of the two grooves is wider than the service limit at any point, replace the piston.

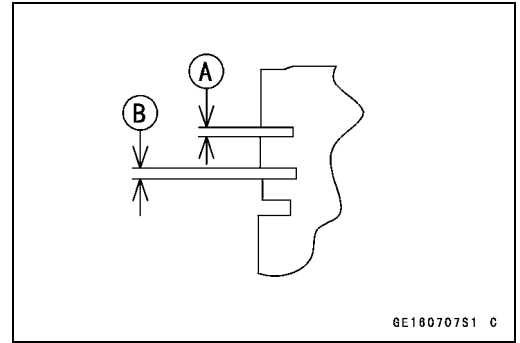

Piston Ring Thickness

- Measure the piston ring thickness.
- Use the micrometer to measure at several points around the ring.

Piston Ring Thickness

Standard:

- Top [A] 0.87 ~ 0.89 mm (0.0343 ~ 0.0350 in.)
- Second [B] 0.97 ~ 0.99 mm (0.0382 ~ 0.0390 in.)

Service Limit:

- Top [A] 0.80 mm (0.032 in.)
- Second [B] 0.90 mm (0.035 in.)

- ★ If any of the measurements is less than the service limit on either of the rings, replace all the rings.

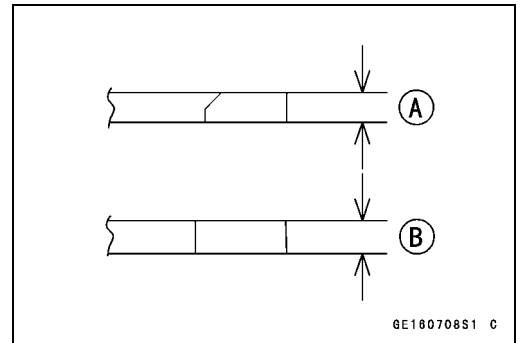

NOTE

- When using new rings in a used piston, check for uneven groove wear. The rings should fit perfectly parallel to the groove sides. If not, replace the piston.

Piston Ring End Gap

- Place the piston ring [A] inside the cylinder (upper crankcase), using the piston to locate the ring squarely in place. Set it close to the bottom of the cylinder, where cylinder wear is low.
- Measure the gap [B] between the ends of the ring with a thickness gauge.

Piston Ring End Gap

Standard:

- Top 0.20 ~ 0.30 mm (0.0079 ~ 0.0118 in.)
- Second 0.40 ~ 0.55 mm (0.0157 ~ 0.0217 in.)

Service Limit:

- Top 0.6 mm (0.024 in.)
- Second 0.8 mm (0.031 in.)

- ★ If the end gap of either ring is greater than the service limit, replace all the rings.

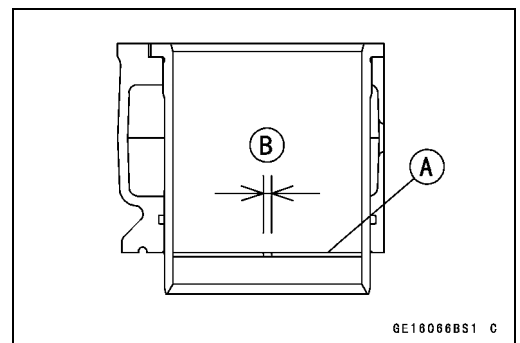

9-30 CRANKSHAFT/TRANSMISSION

Balancer

Front Balancer Removal

- Split the crankcase (see Crankcase Splitting).
- Unscrew:
 - Balancer Shaft Clamp Bolt [A]
 - Balancer Shaft Clamp Lever Bolt [B]
- Remove the front balancer [C] from the lower crankcase half [D]

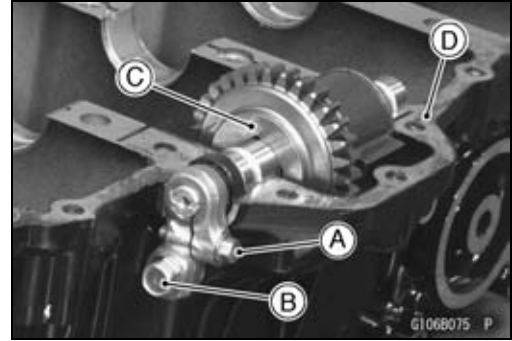

Front Balancer Installation

- Check that the rubber dampers [A] are in place as shown.

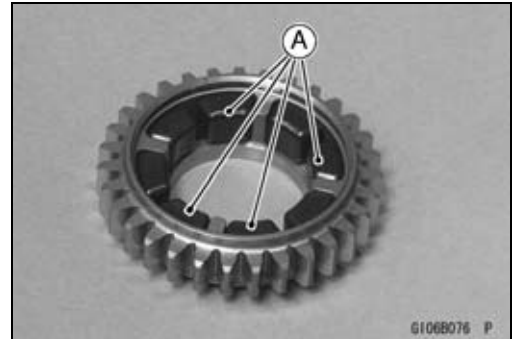

- Apply molybdenum disulfide oil solution to the damper contact portions of the balancer weight.
- Install the balancer weight [A] into the gear [B].
- Align the mark [C] of the balancer weight to the groove [D] of the gear.

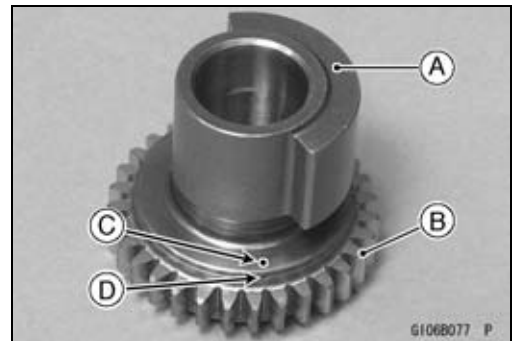

- Apply molybdenum disulfide oil solution to the needle bearings. Insert the needle bearings.
- Fit the copper washers [A] on both ends of the weight and gear assembly. The projected sides [B] face inward.

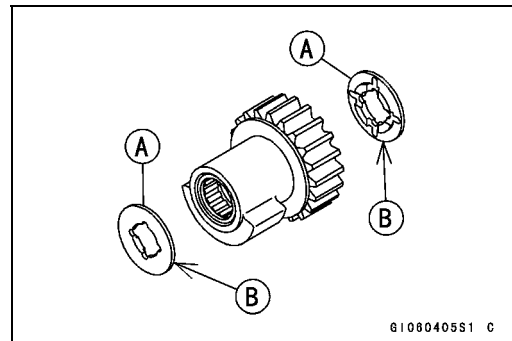

Balancer

- Position the crankshaft at 2, 3 position TDC.
- Insert the pin [A] as shown.
- Set the front balancer on the upper crankcase half.
- Align the punch mark [B] on the balancer gear [C] with the mark [D] on the balancer drive gear [E] of crankshaft.

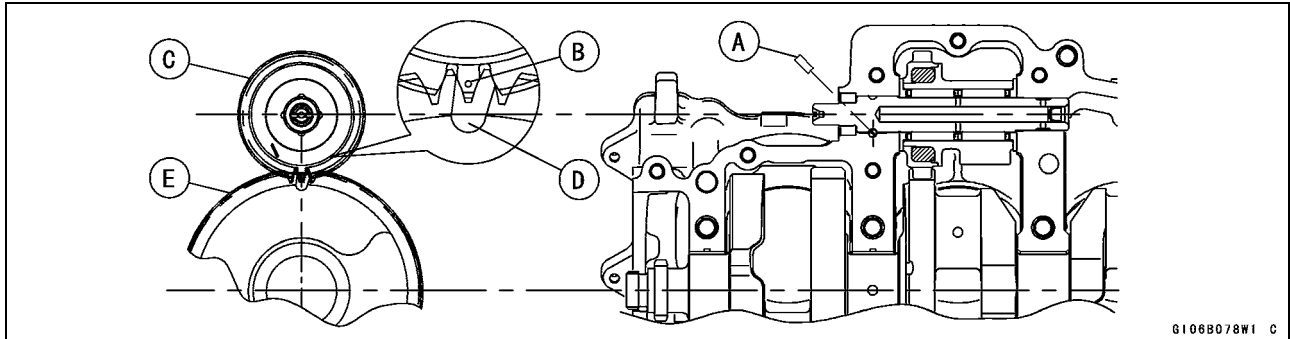

G1068078W1 C

- Assemble the crankcase (see Crankcase Assembly).
- Install the new oil seal [A] so that its surface [B] is flush with the surface of the crankcase [C].
- Fill the oil seal lips with grease.
- Tighten the balancer shaft clamp lever bolt [D]

Torque - Balancer Shaft Clamp Lever Bolt: 25 N·m (2.5 kgf·m, 18 ft·lb)

- Turn the balancer shaft so that its mark [E] is aligned with the crankcase mating line [F].
- Tighten the balancer shaft clamp bolt [G]

Torque - Balancer Shaft Clamp Bolt: 9.8 N·m (1.0 kgf·m, 87 in·lb)

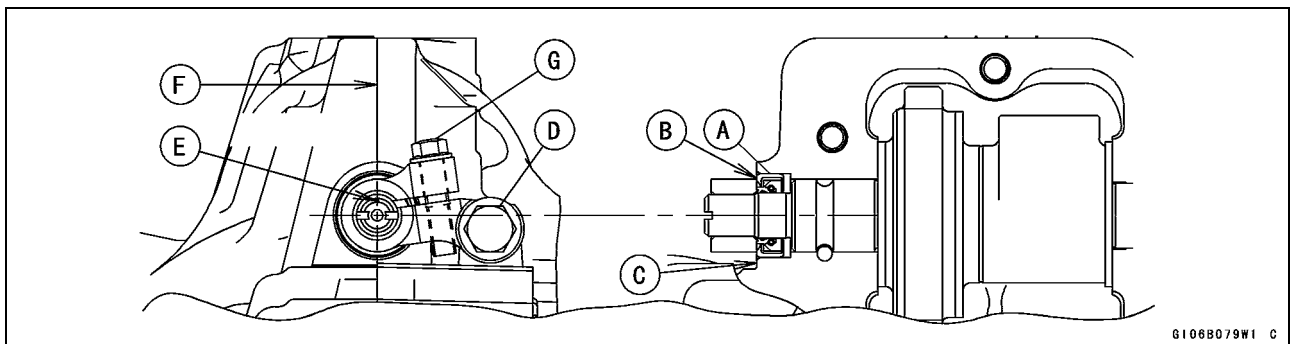

G1068079W1 C

Rear Balancer Removal

- Remove the engine (see Engine Removal in the Engine Removal/Installation chapter).
- Remove:
 - Breather Cover Bolts [A]
 - Breather Cover [B]

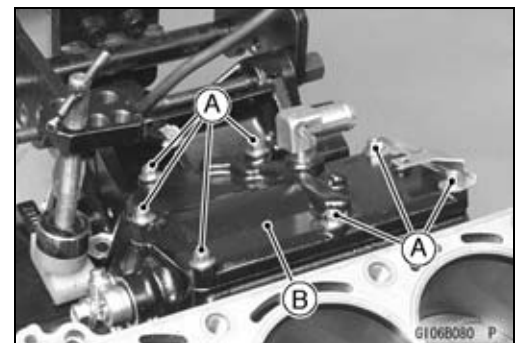

G1068080 P

9-32 CRANKSHAFT/TRANSMISSION

Balancer

- Unscrew the balancer shaft clamp bolt [A], and balancer shaft clamp lever bolt [B], and pull off the clamp lever [C].
- Pull the balancer shaft [D] out of the crankcase. The balancer weight and gear assembly [E] come off with needle bearings and copper washers.

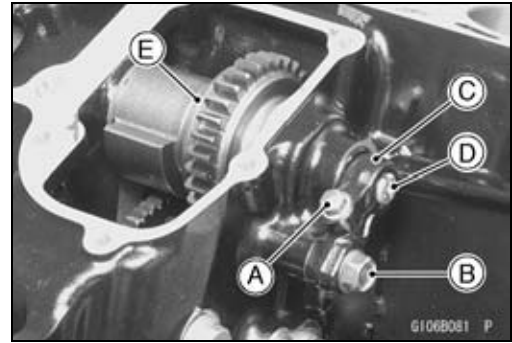

Rear Balancer Installation

- Check that the rubber dampers [A] are in place as shown.

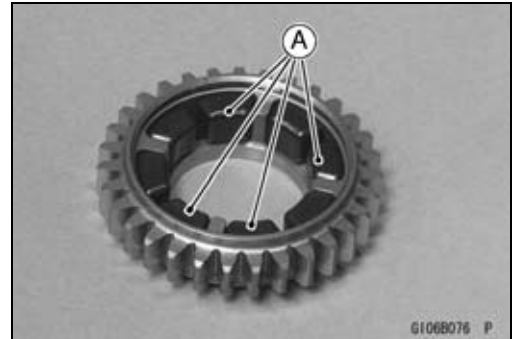

- Apply molybdenum disulfide oil solution to the damper contact portions of the balancer weight.
- Install the balancer weight [A] into the gear [B].
- Align the mark [C] of the balancer weight to the groove [D] of the gear.

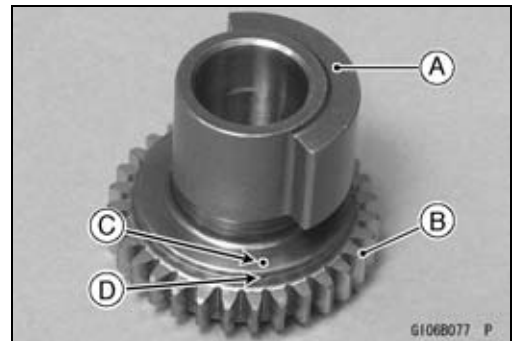

- Apply molybdenum disulfide oil solution to the needle bearings. Insert the needle bearings.
- Fit the copper washers [A] on both ends of the weight and gear assembly. The projected sides [B] face inward.

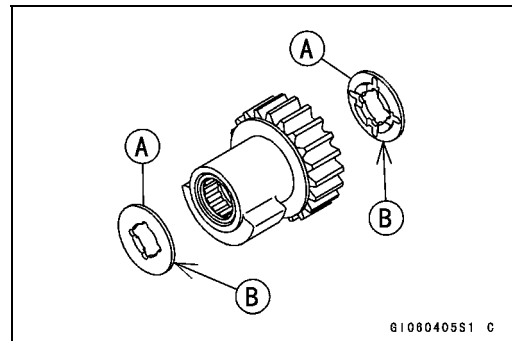

Balancer

- Position the crankshaft at # 2, 3 position TDC or at # 1, 4 position TDC.
- Align the mark [A] on the balancer gear [B] with the mating surface [C] of the upper crankcase half.
- Install the balancer shaft [D] and then align the balancer gear with the starter motor clutch gear.

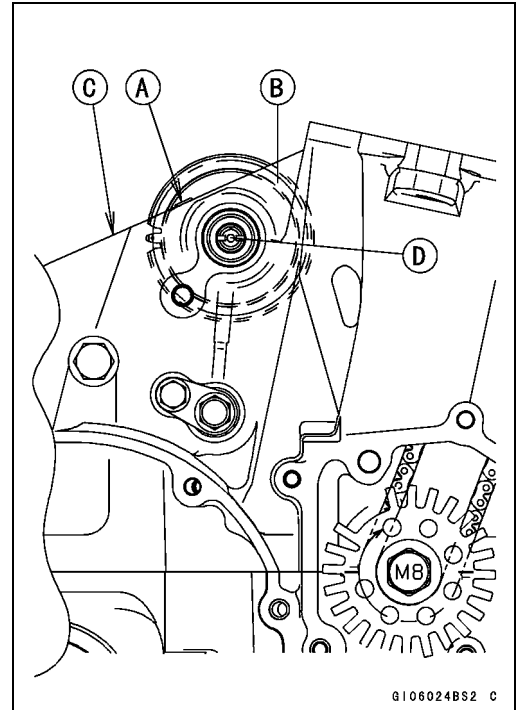

- Install the new oil seal [A] so that its surface [B] is flush with the surface of crankcase [C].
- Fill the oil seal lips with grease.
- Tighten the balancer shaft clamp lever bolt [D].

Torque - Balancer Shaft Clamp Lever Bolt: 25 N·m (2.5 kgf·m, 18 ft·lb)

- Turn the balancer shaft so that its mark [E] is in position as shown.
- Tighten the balancer shaft clamp bolt [F].

Torque - Balancer Shaft Clamp Bolt: 9.8 N·m (1.0 kgf·m, 87 in·lb)

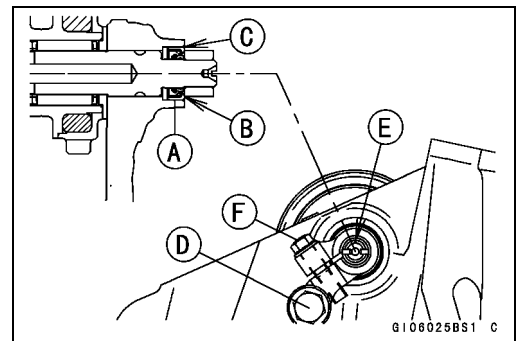

9-34 CRANKSHAFT/TRANSMISSION

Balancer

Balancer Adjustment

- First, adjust the front balancer [A], next the rear balancer [B].
- For the front balancer adjustment, remove the lower fairing (see Lower Fairing Removal in the Frame chapter).
- Start the engine and warm it up thoroughly.
- Adjust the balancer gear backlash with the engine idling. The amount of backlash can be changed by turning the balancer shaft which has eccentric journals.
- Start the engine and let it idle.
- Loosen the clamp bolt [C] and turn the balancer shaft [D] clockwise [E] until the balancer gear makes a whining sound.
- Turn the shaft counter-clockwise [F] until the balancer gear whining sound disappears and tighten the clamp bolt.

Torque - Balancer Shaft Clamp Bolt: 9.8 N·m (1.0 kgf·m, 98 in·lb)

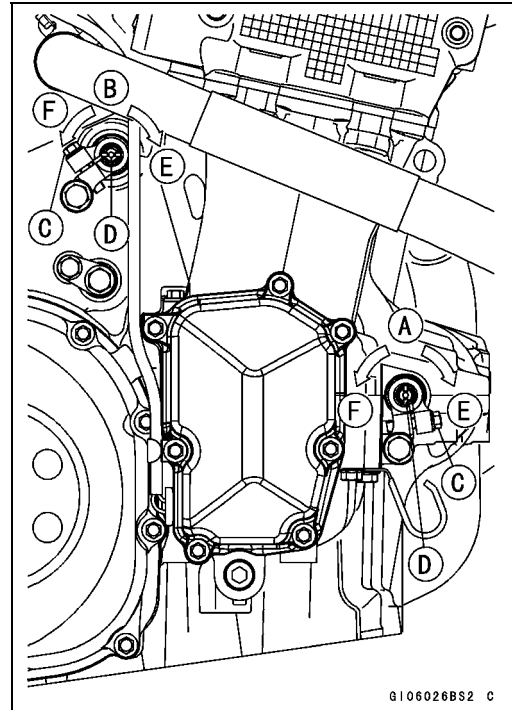

Balancer Damper Inspection

- Remove the balancer and disassemble the weight and gear assembly.
- Visually inspect the rubber dampers [A].
- ★ If they appear damaged or deteriorated, replace them.

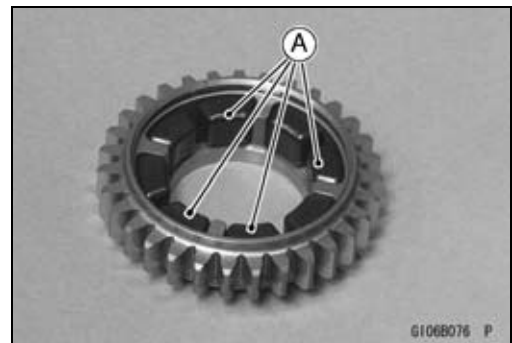

Starter Motor Clutch and Torque Limiter

Starter Motor Clutch Removal

- Remove the engine (see Engine Removal in the Engine Removal/Installation chapter).
- Remove the rear balancer (see Rear Balancer Removal).
- Unscrew the starter clutch shaft plate bolt [A].



- Pull the starter clutch shaft bolt [A] with the shaft plate [B] and starter clutch shaft holding the starter clutch [C].
- Remove the starter clutch.

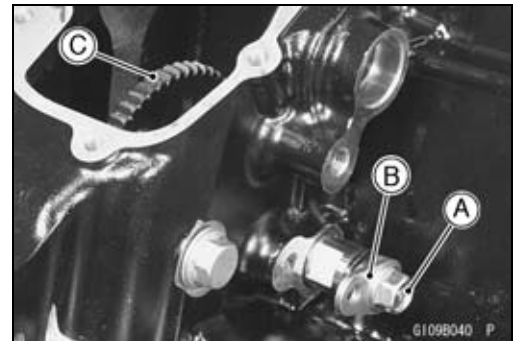

Starter Motor Clutch Installation

- Install:
 - Coller (Long) [A]
 - Starter Motor Clutch [B]
 - Coller (Short) [C]
 - Starter Motor Clutch Shaft [D]
- Apply molybdenum disulfide grease [E] to the starter motor clutch shaft.
- Align [F] the starter motor clutch gear with the torque limiter gear.
- Apply a non-permanent locking agent to the threads of the starter clutch shaft plate bolt, and tighten it.

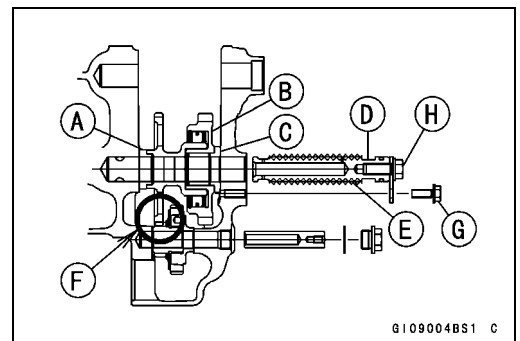

Torque - Starter Clutch Shaft Plate Bolt [G]: 9.8 N·m (1.0 kgf·m, 87 in·lb)

- ★ If the shaft bolt removed, tighten it.
- Apply a non-permanent locking agent to the threads of the shaft bolt.

Torque - Starter Clutch Shaft Bolt [H]: 9.8 N·m (1.0 kgf·m, 87 in·lb)

Starter Motor Clutch Disassembly

- Remove the starter motor clutch.
- Pull the driven gear out off from the drive gear.
- Remove:
 - Flat Washer [A]



9-36 CRANKSHAFT/TRANSMISSION

Starter Motor Clutch and Torque Limiter

- Holding the drive gear [A] with a hand, take off the one-way clutch [B] from the gear by using the screw driver [C].

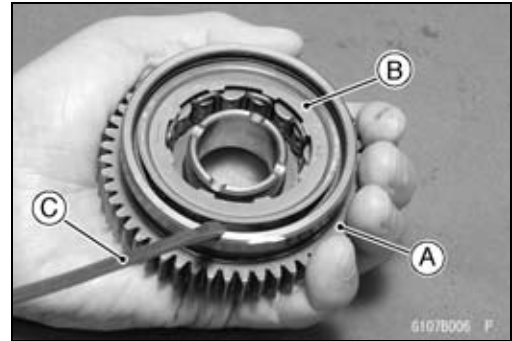

Starter Motor Clutch Assembly

- Be sure to install the one-way clutch [A] so that its arrow [B] faces the side of the flat washer.

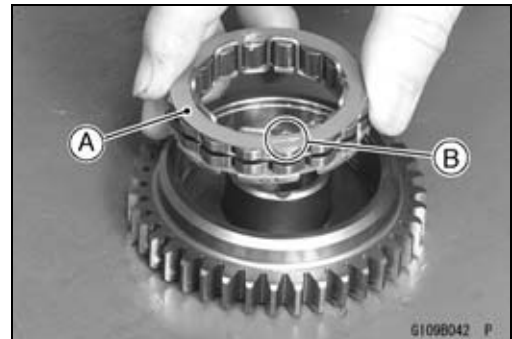

- Turn in the driven gear [A] to the drive gear [B]. Counterclockwise [C]

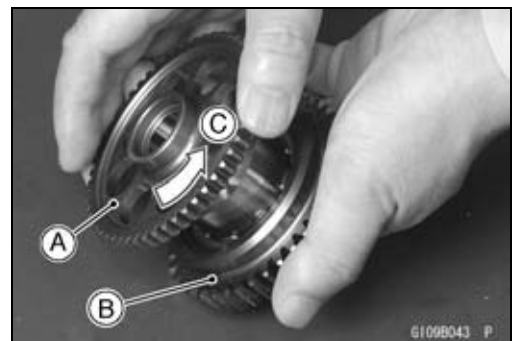

Starter Clutch Inspection

- Remove the rear balancer (see Rear Balancer Removal).
- Turn the starter idle gear [A] by hand. When viewed from the rear side of the engine, the starter idle gear should turn forward [B] freely, but should not turn backward [C].
- ★ If the clutch does not operate as it should or if it makes noise, disassemble the starter clutch, examine each part visually, and replace any worn or damaged parts.



Torque Limiter Removal

- Remove:
 - Rear Balancer (see Rear Balancer Removal)
 - Starter Motor Clutch (see Starter Motor Clutch Removal).
- Remove the torque limiter bolt [A].

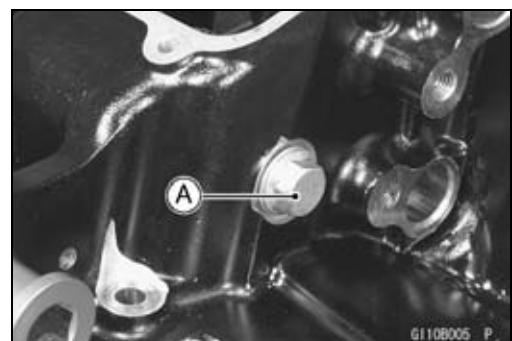

Starter Motor Clutch and Torque Limiter

- Holding the torque limiter [A], remove the torque limiter shaft [B] and the torque limiter.



Torque Limiter Installation

- Replace the O-ring with a new one.
- Apply engine oil to the new O-ring.
- Apply molybdenum disulfide grease to the torque limiter shaft.
- Install the torque limiter bolt.
- Apply a non-permanent locking agent to the bolt.

Torque - Torque Limiter Bolt: 25 N·m (2.5 kgf·m, 18 ft·lb)

9-38 CRANKSHAFT/TRANSMISSION

Transmission

Shift Pedal Removal

- Remove:
 - Shift Lever Bolt [A]
 - Shift Lever [B]

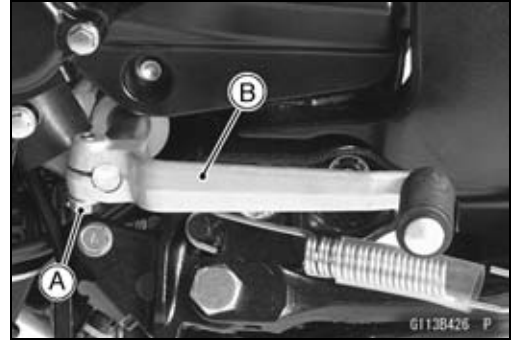

Shift Pedal Installation

- Install the shift pedal.
- Align [A] the punch mark [B] on the shift shaft with the upper surface [C] of shift lever slit.
- Tighten the shift pedal bolt securely.

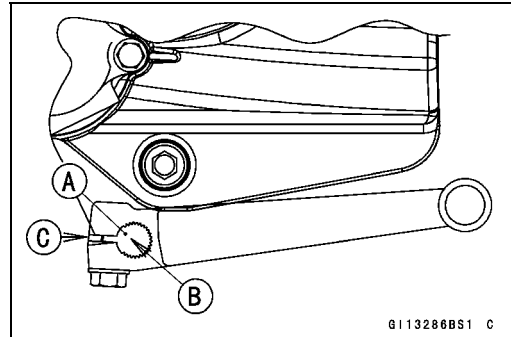

External Shift Mechanism Removal

- Remove:
 - Shift Pedal (see Shift Pedal Removal)
 - Snap Ring [A] and Washer [B]
 - Clutch (see Clutch Removal in the Clutch chapter)

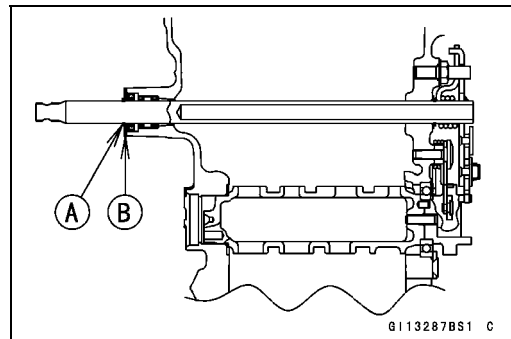

- Remove the shift shaft assembly [A] while pulling the shift mechanism arm.

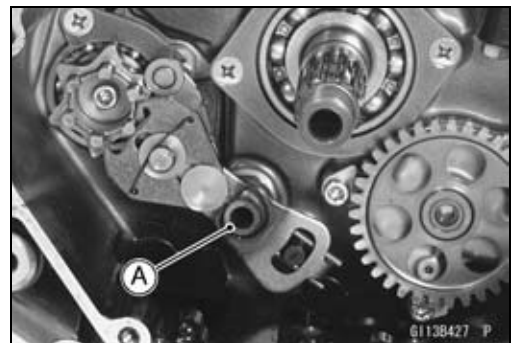

- Remove:
 - Gear Positioning Lever Bolt [A]
 - Gear Positioning Lever [B], Collar and Spring

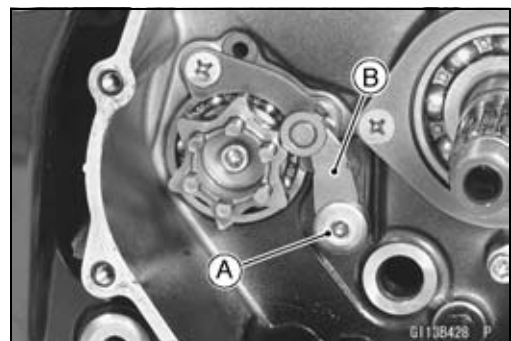

Transmission

External Shift Mechanism Installation

- Install the gear positioning lever [A] as shown.
 - Spring [B]
 - Collar [C]
 - Bolt [D]
- Tighten:
 - Torque - Gear Positioning Lever Bolt: 12 N·m (1.2 kgf·m, 106 in·lb)**

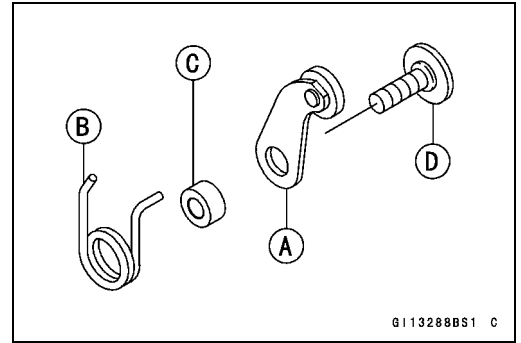

External Shift Mechanism Inspection

- Examine the shift shaft [A] for any damage.
 - ★ If the shaft is bent, straighten or replace it.
 - ★ If the serration [B] are damaged, replace the shaft.
 - ★ If the springs [C] are damaged in any way, replace them.
 - ★ If the shift mechanism arm [D] is damaged in any way, replace the arm.

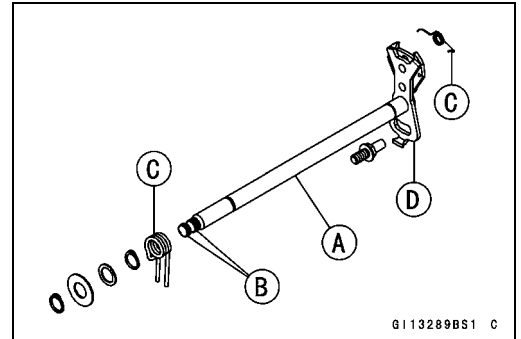

- Check the return spring pin [A] is not loose.
 - ★ If it is loose, unscrew it, apply a non-permanent locking agent to the threads, and tighten it.

Torque - Shift Shaft Return Spring Pin: 29 N·m (3.0 kgf·m, 21 ft·lb)

- Check the gear positioning lever [B] and its spring for breaks or distortion.
 - ★ If the lever or spring are damaged in any way, replace them.
- Visually inspect the shift drum cam [C].
 - ★ If they are badly worn or if they show any damage, replace it.

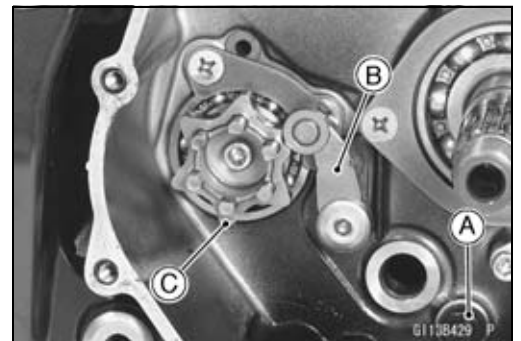

Transmission Shaft Removal

- Split the crankcase (see Crankcase Splitting).
- Remove the output shaft [A].

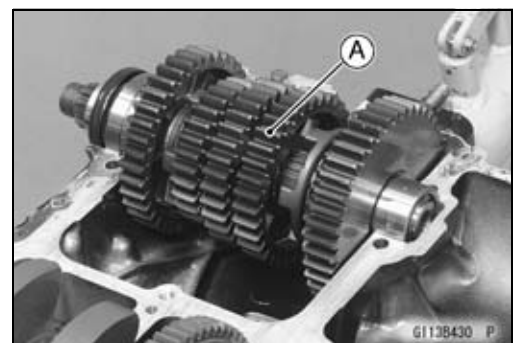

9-40 CRANKSHAFT/TRANSMISSION

Transmission

- Remove the cover bolts [A] and cover [B].
- Remove the shift forks (see Shift Drum and Fork Removal).
- Pull out the drive shaft.

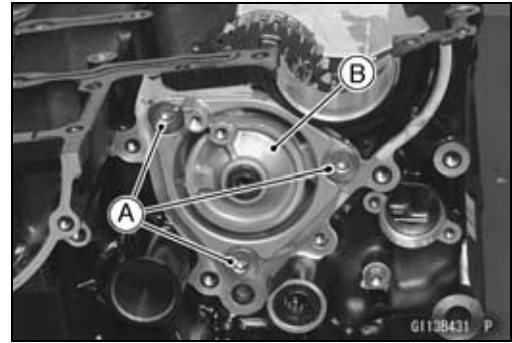

Transmission Shaft Installation

- Check to see that the set pin [A] and set ring [B] are in place.
 - Install the output shaft into the upper crankcase half.
 - Apply engine oil to the bearing.
- The bearing set pin and ring must match properly with the hole or groove in the bearing outer races. When they are properly matched, there is no clearance between the crankcase and the bearing outer races.

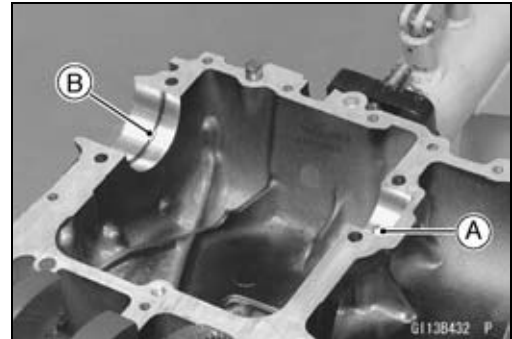

- Install the drive shaft into the lower crankcase half.
- Apply grease to the O-ring.
- Install the cover.
- Apply a non-permanent locking agent to the drive shaft cover bolts and tighten them.

Torque - Drive Shaft Cover Bolts [A]: 25 N·m (2.5 kgf·m, 18 ft·lb)

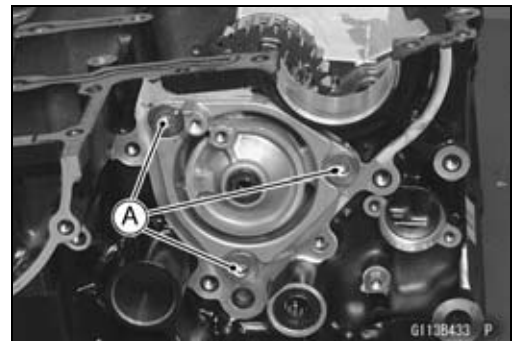

- Assemble the crankcase.
- Press in the oil seal [A] onto collar [B] so that the surface of the oil seal is flush with the counterbore bottom surface [C] of the crankcase.

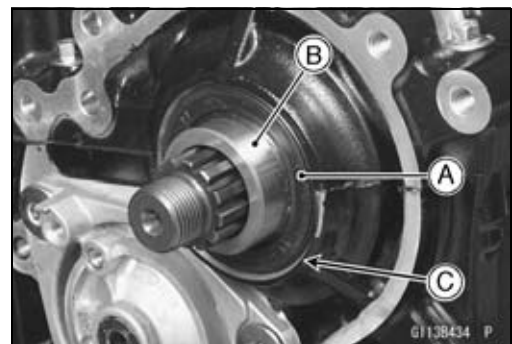

Transmission Shaft Disassembly

- Remove the transmission shafts (see Transmission Shaft Removal).
 - Remove the circlips, disassemble the transmission shafts.
 - The 5th gear [A] on the output shaft has three steel balls assembled into it for the positive neutral finder mechanism. Remove the 5th gear.
- Set the output shaft in a vertical position holding the 3rd gear [B].
- Spin the 5th gear quickly [C] and pull it off upward.

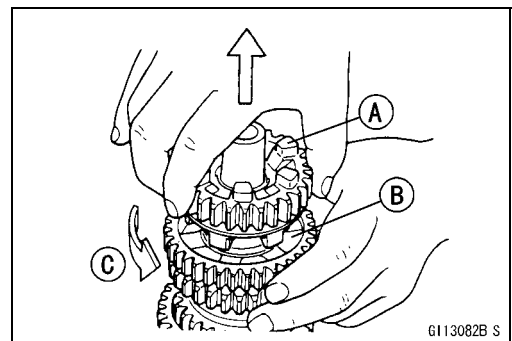

Transmission

- Remove the ball bearing [A] from each shafts.
Special Tools - Bearing Puller [B]: 57001-135
Bearing Puller Adapter [C]: 57001-317
- Discard the bearing.

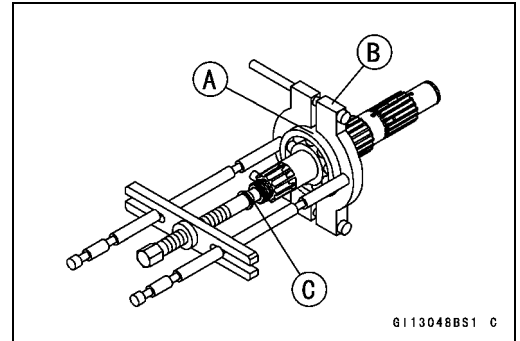

Transmission Shaft Assembly

- Apply engine oil to the bushings, ball bearings and shafts.
- Install the gear bushings [A] on the shaft with their holes [B] aligned.

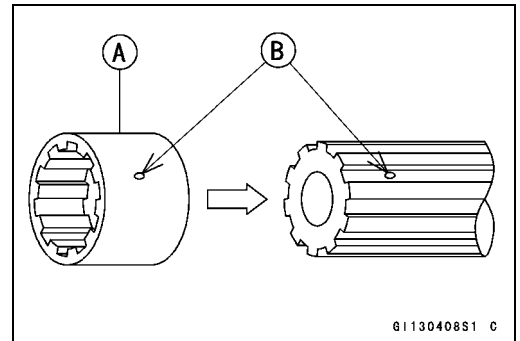

- Replace any circlips removed with new ones.
- Install the circlips [A] so that the opening [B] of it is aligned with spline grooves [C].
- Install the circlips so that the mark [D] on them faces to each gear side.

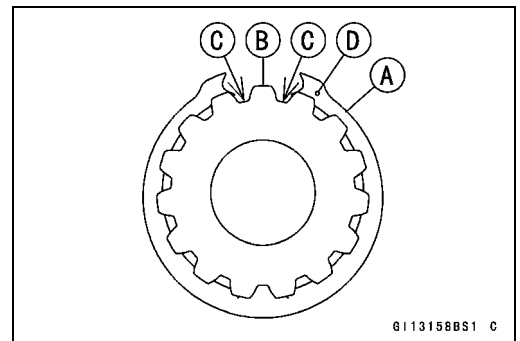

- The drive shaft gears can be recognized by size: the gear with the smallest diameter is 1st gear, and the largest one is 6th gear. Be sure that all parts are put back in the correct sequence and all circlips and washers are properly in place.
- Install the 3rd/4th gear onto the drive shaft with their oil holes aligned.
- Install the 6th gear bushing onto the drive shaft with their oil holes aligned.
- The output shaft gears can be recognized by size: the gear with the largest diameter is 1st gear, and the smallest one is 6th gear. Be sure that all parts are put back in the correct sequence and all circlips and washers are properly in place.
- Install the 5th and 6th gears onto the output shaft with their oil holes aligned.
- Install the 3rd/4th gear bushings onto the output shaft with their oil holes aligned.

9-42 CRANKSHAFT/TRANSMISSION

Transmission

- Fit the steel balls into the 5th gear holes in the output shaft, aligning three oil holes [D].
5th Gear [A]
Output Shaft [B]
Steel Balls [C]

CAUTION

Do not apply grease to the balls to hold them in place. This will cause the positive neutral finder mechanism to malfunction.

- After assembling the 5th gear with steel balls in place on the output shaft, check the ball-locking effect that the 5th gear doesn't come out of the output shaft when moving it up and down by hand.
- Check that each gear spins or slides freely on the transmission shafts without binding after assembly.

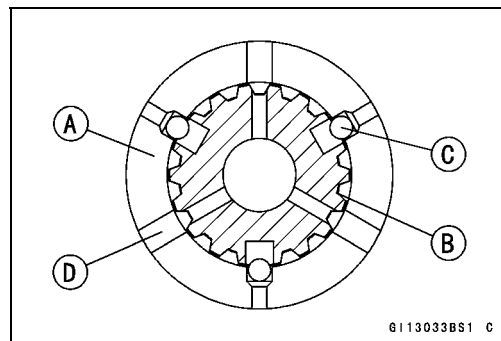

Transmission

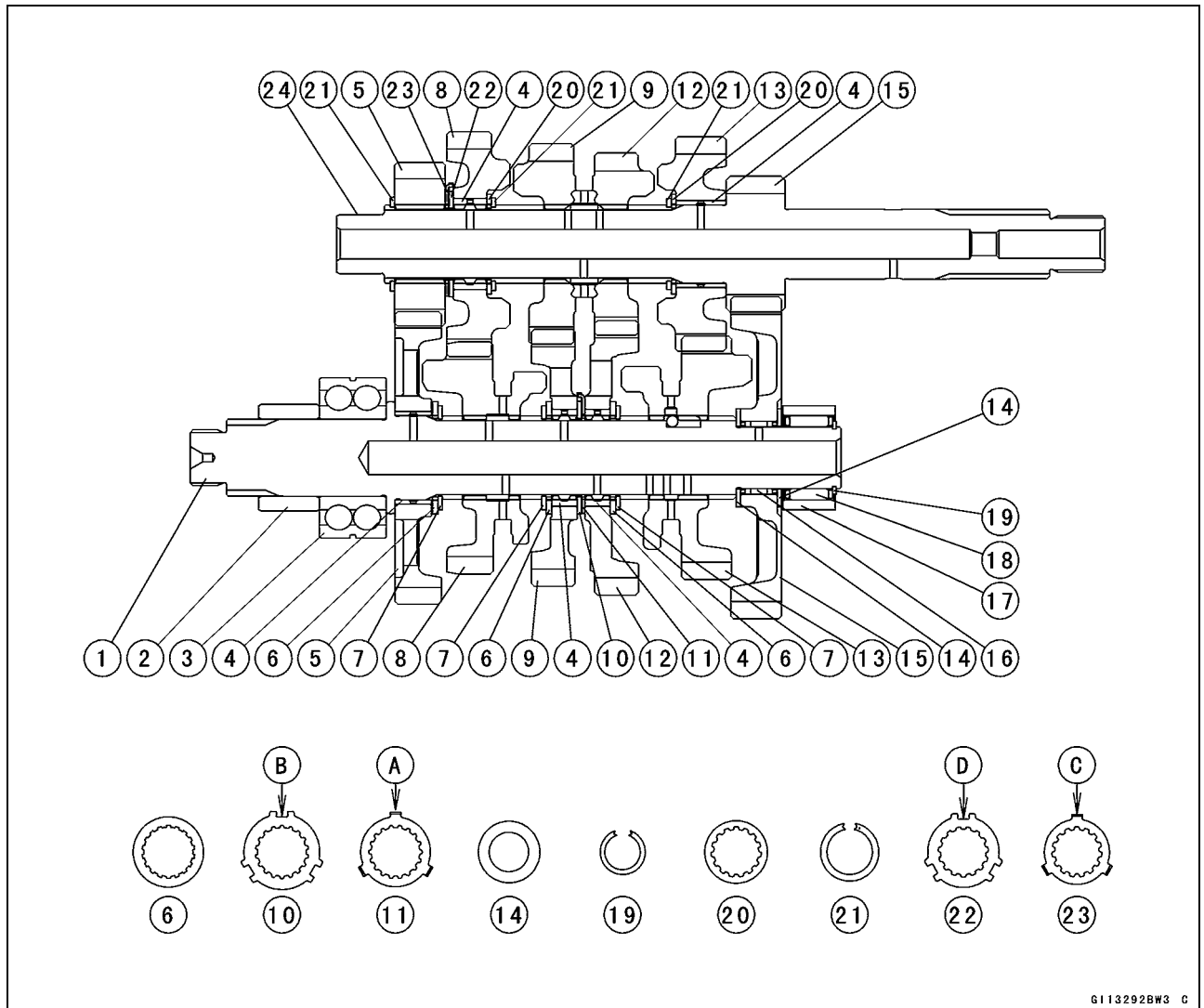

6113292BW3 C

- | | |
|---|--|
| 1. Output Shaft | 13. 5th Gear |
| 2. Collar | 14. Thrust Washer, $\phi 35$ mm (1.38 in.) |
| 3. Ball Bearing | 15. 1st Gear |
| 4. Bushing | 16. Needle Bearing |
| 5. 2nd Gear | 17. Bearing Outer Race |
| 6. Toothed Washer, $\phi 30$ mm (1.18 in.) | 18. Needle Bearing |
| 7. Circlip | 19. Snap Ring, $\phi 25.5$ mm (1.00 in.) |
| 8. 6th (Top) Gear | 20. Toothed Washer, 35.5 mm (1.40 in.) |
| 9. 4th Gear | 21. Snap Ring, 33 mm (1.30 in.) |
| 10. Toothed Washer, $\phi 43$ mm (1.69 in.) | 22. Toothed Washer, 40.5 mm (1.59 in.) |
| 11. Toothed Washer, 39.7 mm (1.56 in.) | 23. Toothed Washer, 37 mm (1.46 in.) |
| 12. 3rd Gear | 24. Drive Shaft |

○When the tangs [A] of the toothed washer [11] shall be assembled, they shall be installed into the notches [B] of the toothed washer [10].

○When the tangs [C] of the toothed washer [23] shall be assembled, they shall be installed into the notches [D] of the toothed washer [22].

9-44 CRANKSHAFT/TRANSMISSION

Transmission

Shift Drum and Fork Removal

- Remove:
 - Lower Crankcase Half (see Crankcase Splitting)
 - External Shift Mechanism (see External Shift Mechanism Removal)
 - Screws [A]
 - Shift Drum Bearing Holder [B]
- Pull out the shift rods [C], and take off the shift forks.
- Pull out the shift drum [D].

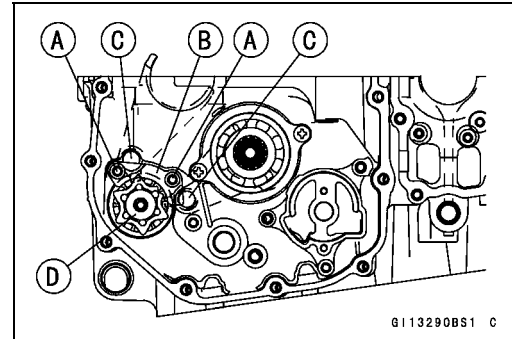

Shift Drum and Fork Installation

- Apply engine oil to the shift drum, forks and rods.
- Install the shift rods [A], noting the groove position.
- Position the one with shortest ears [B] on the drive shaft and place the pin in the center groove in the shift drum.
- The two forks [C] on the output shaft are identical.

NOTE

- The forks have marks (029 [D], 030 [E]), and position them so that so that their marks face the engine left side.

- Install the forks as shown.
- Apply a non-permanent locking agent to the threads of the shift drum bearing holder screws and tighten them.

Torque - Shift Drum Bearing Holder Screws: 4.9 N·m (0.50 kgf·m, 43 in·lb)

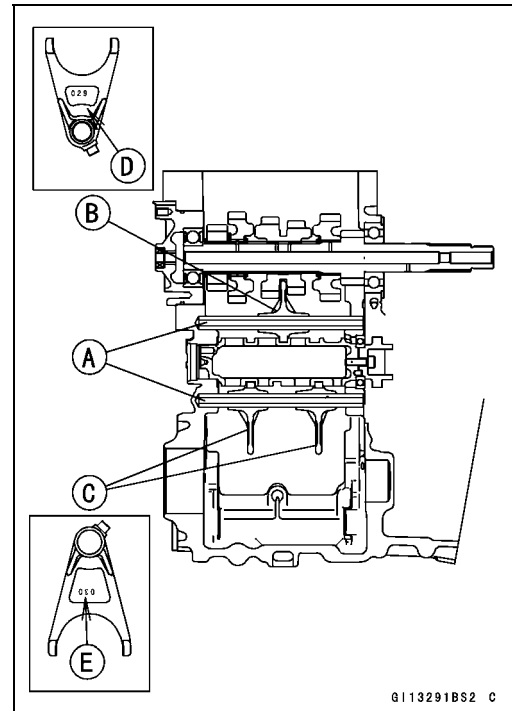

Shift Drum Disassembly

- Remove the shift drum (see Shift Drum and Fork Removal).
- While holding the shift drum with a vise, remove the shift drum cam holder bolt.
 - Shift Drum Cam Holder Bolt [A]
 - Dowel Pin [B]

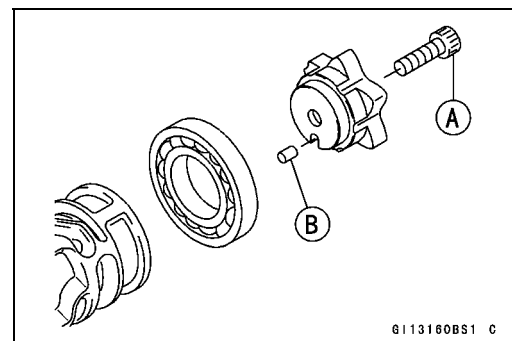

Shift Drum Assembly

- Be sure to install the dowel pin.
- Apply a non-permanent locking agent to the threads of the shift drum cam holder bolt, and tighten it.

Torque - Shift Drum Cam Holder Bolt: 12 N·m (1.2 kgf·m, 106 in·lb)

Transmission

Shift Fork Bending

- Visually inspect the shift forks, and replace any fork that is bent. A bent fork could cause difficulty in shifting, or allow the transmission to jump out of gear when under power.
- 90° [A]

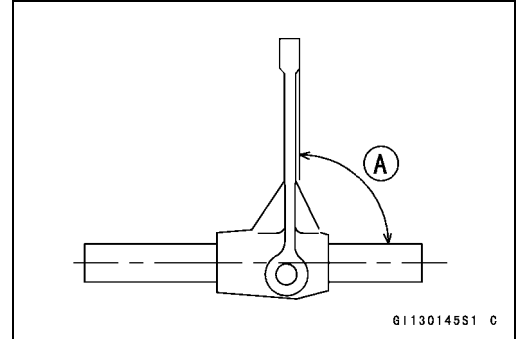

Shift Fork/Gear Groove Wear

- Measure the thickness of the shift fork ears [A], and measure the width [B] of the gear grooves.
- ★ If the thickness of a shift fork ear is less than the service limit, the shift fork must be replaced.

Shift Fork Ear Thickness

- Standard: 5.74 ~ 6.000 mm (0.2260 ~ 0.2362 in.)
- Service Limit: 5.6 mm (0.220 in.)

- ★ If the gear groove is worn over the service limit, the gear must be replaced.

Gear Groove Width

- Standard: 6.05 ~ 6.15 mm (0.238 ~ 0.242 in.)
- Service Limit: 6.25 mm (0.246 in.)

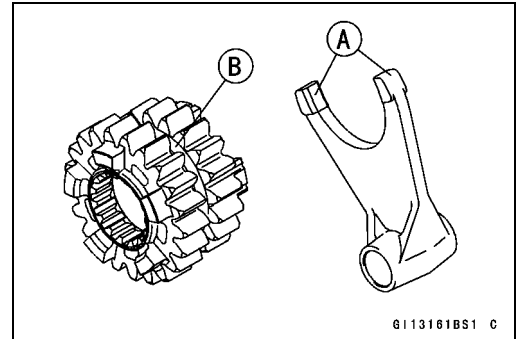

Shift Fork Guide Pin/Drum Groove Wear

- Measure the diameter of each shift fork guide pin [A], and measure the width [B] of each shift drum groove.
- ★ If the guide pin on any shift fork is less than the service limit, the fork must be replaced.

Shift Fork Guide Pin Diameter

- Standard: 6.9 ~ 7.0 mm (0.272 ~ 0.276 in.)
- Service Limit: 6.8 mm (0.268 in.)

- ★ If any shift drum groove is worn over the service limit, the drum must be replaced.

Shift Drum Groove Width

- Standard: 7.05 ~ 7.20 mm (0.278 ~ 0.283 in.)
- Service Limit: 7.3 mm (0.287 in.)

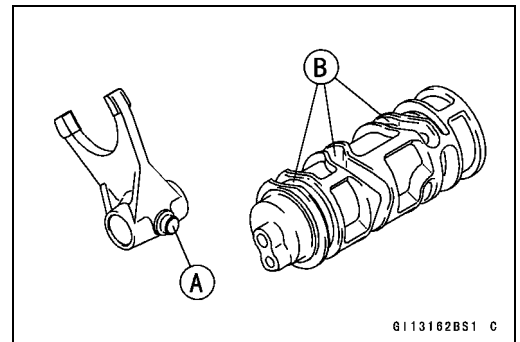

Gear Dog and Gear Dog Hole Damage

- Visually inspect the gear dogs [A] and gear dog holes [B].
- ★ Replace any damaged gears or gears with excessively worn dogs or dog holes.

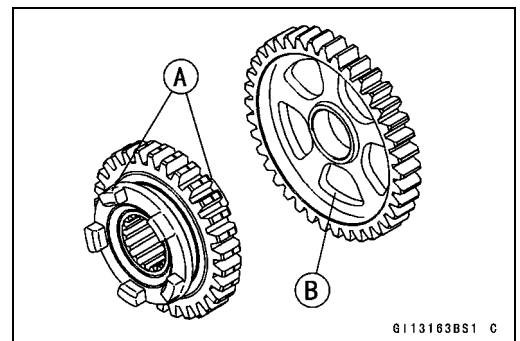

Wheels/Tires

Table of Contents

Exploded View	10-2
Specifications	10-4
Special Tools	10-5
Wheels (Rims)	10-6
Front Wheel Removal	10-6
Front Wheel Installation	10-6
Rear Wheel Removal	10-7
Rear Wheel Installation	10-8
Wheel Inspection	10-10
Axle Inspection	10-10
Balance Inspection	10-11
Balance Adjustment	10-11
Balance Weight Removal	10-11
Balance Weight Installation	10-12
Tires	10-14
Air Pressure Inspection/Adjustment	10-14
Tire Inspection	10-14
Tire Removal	10-14
Tire Installation	10-14
Tire Repair	10-16
Hub Bearing	10-17
Hub Bearing Removal	10-17
Hub Bearing Installation	10-17
Hub Bearing Inspection	10-17
Hub Bearing Lubrication	10-18

10-2 WHEELS/TIRES

Exploded View

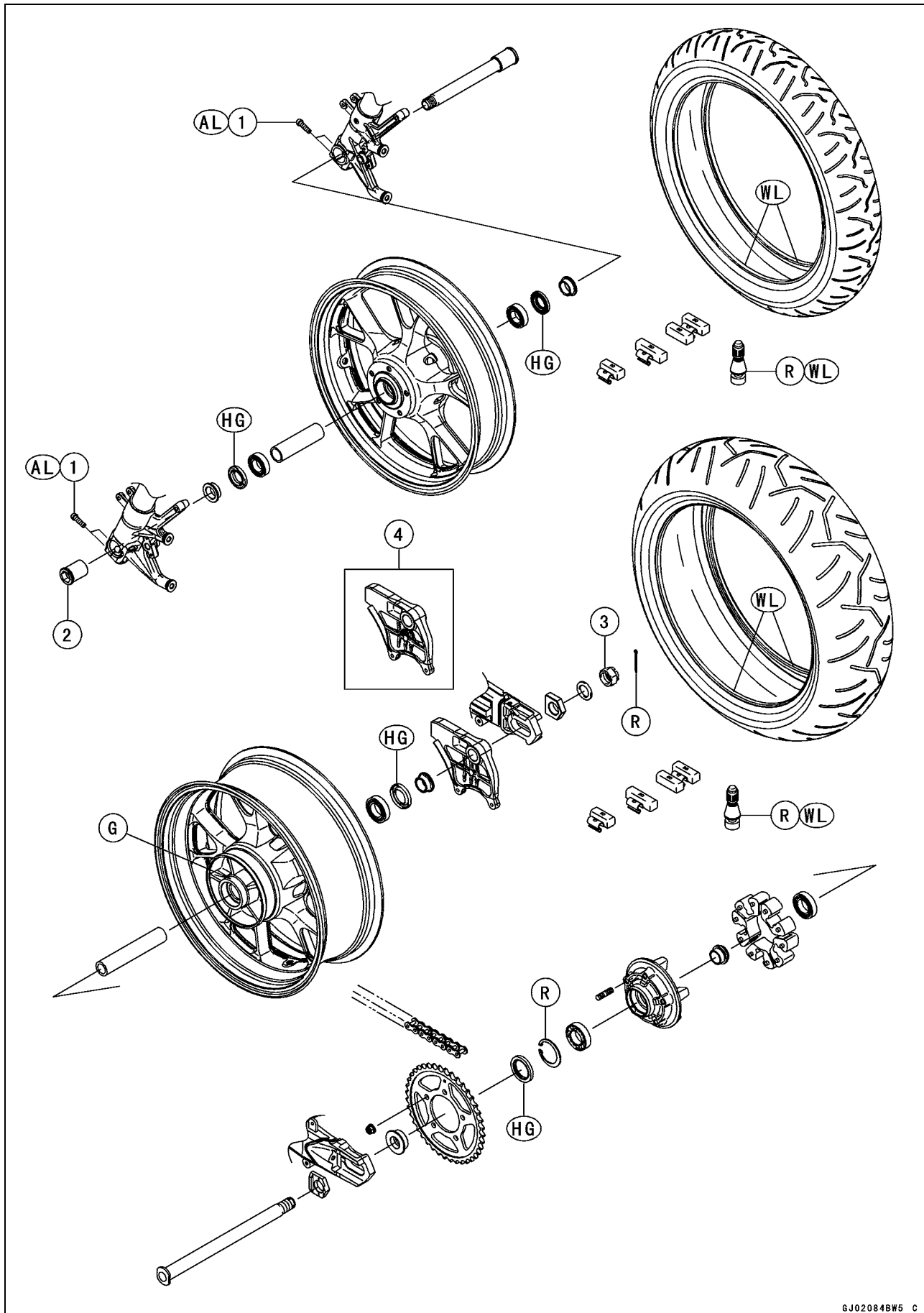

Exploded View

No.	Fastener	Torque			Remarks
		N·m	kgf·m	ft·lb	
1	Front Axle Clamp Bolts	20	2.0	15	AL
2	Front Axle Nut	127	13.0	94	
3	Rear Axle Nut	127	13.0	94	

4. Caliper Bracket (ZX1400B Models)

AL: Tighten the two clamp bolts alternately two time to ensure even tightening.

G: Apply grease.

HG: Apply high-temperature grease.

R: Replacement Parts

WL: Apply soap and water solution or rubber lubricant.

10-4 WHEELS/TIRES

Specifications

Item	Standard	Service Limit
Wheels (Rims)		
Rim Runout:		
Axial	TIR 0.5 mm (0.02 in.) or less	TIR 1.0 mm (0.04 in.)
Radial	TIR 0.8 mm (0.03 in.) or less	TIR 1.0 mm (0.04 in.)
Axle Runout/100 mm (3.94 in.)	TIR 0.03 mm (0.0012 in.) or less	TIR 0.2 mm (0.01 in.)
Wheel Balance	10 g (0.35 oz.) or less	— — —
Balance Weights	10 g (0.35 oz.), 20 g (0.71 oz.), 30 g (1.06 oz.)	— — —
Rim Size:		
Front	17 × 3.50	— — —
Rear	17 × 6.00	— — —
Tires		
Air Pressure (when Cold):		
Front	Up to 180 kg (397 lb) load: 290 kPa (2.9 kgf/cm ² , 42 psi)	— — —
Rear	Up to 180 kg (397 lb) load: 290 kPa (2.9 kgf/cm ² , 42 psi)	— — —
Tread Depth:		
Front	3.8 mm (0.15 in.)	1 mm (0.04 in.) (AT, CH, DE) 1.6 mm (0.06 in.)
Rear	4.8 mm (0.19 in.)	Up to 130 km/h (80 mph): 2 mm (0.08 in.) Over 130 km/h (80 mph): 3 mm (0.12 in.)
Standard Tires:	Make, Type	Size
Front	BRIDGESTONE, BATTLAX BT014 F RADIAL SL	120/70 ZR17 M/C (58 W)
Rear	BRIDGESTONE, BATTLAX BT014 R RADIAL L	190/50 ZR17 M/C (73 W)

WARNING

Use the same manufacturer's tires on both front and rear wheels.

Special Tools

Bearing Driver Set:
57001-1129

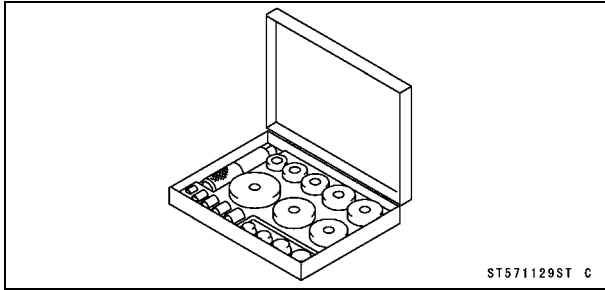

Bearing Remover Shaft, $\phi 13$:
57001-1377

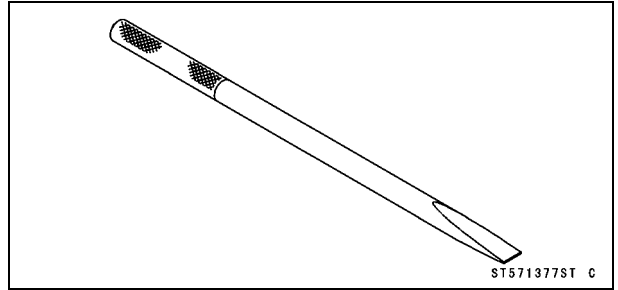

Jack:
57001-1238

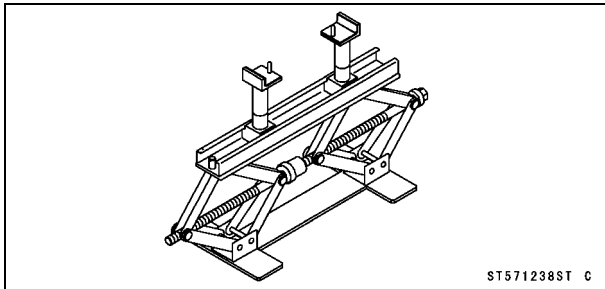

Jack Attachment:
57001-1608

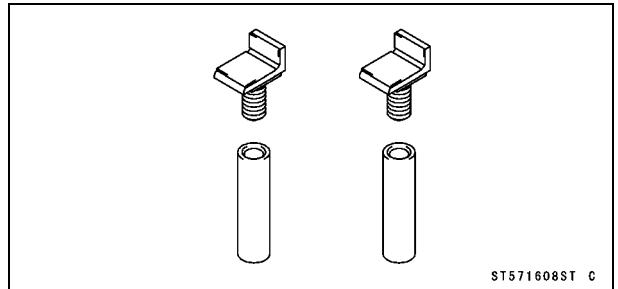

Bearing Remover Head, $\phi 25 \times \phi 28$:
57001-1346

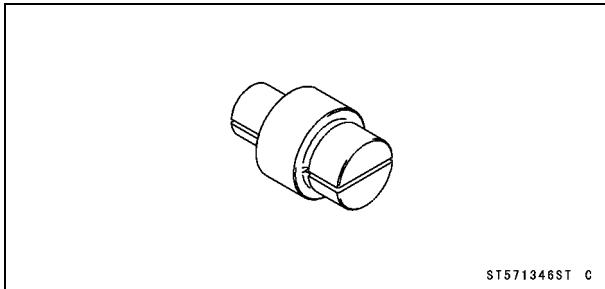

10-6 WHEELS/TIRES

Wheels (Rims)

Front Wheel Removal

- Remove:
 - Front Caliper Mounting Bolts [A]
 - Front Calipers [B]

- Loosen:
 - Axle Clamp Bolts [A] (Left Side)
 - Axle Nut [B]
 - Axle Clamp Bolts (Right Side)

- Remove the lower fairings (see Lower Fairing Removal in the Frame chapter).
- Raise the front wheel off the ground with the jack.
 - Special Tools - Jack: 57001-1238**
 - Jack Attachment: 57001-1608**
- Remove the axle nut and pull out the axle to the right and drop the front wheel out of the forks.

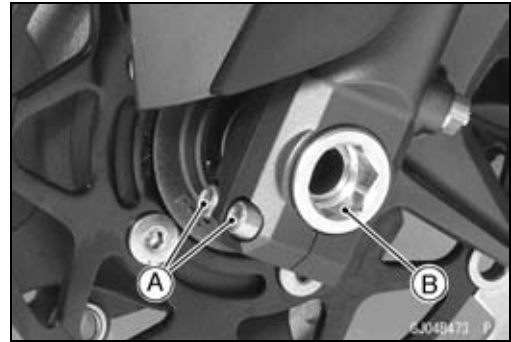
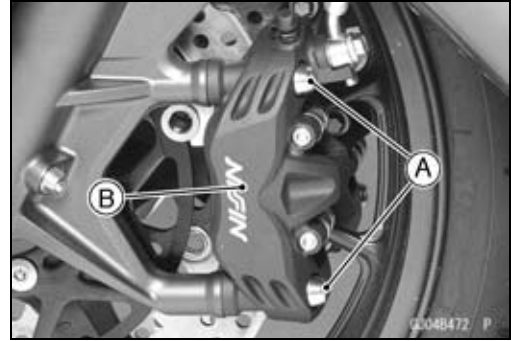

CAUTION

Do not lay the wheel down on one of the discs. This can damage or warp the disc. Place blocks under the wheel so that the disc does not touch the ground.

Front Wheel Installation

NOTE

- The direction of the wheel rotation [A] is shown by an arrow [B] on the wheel spoke.
- Check the wheel rotation mark on the front wheel and install it.

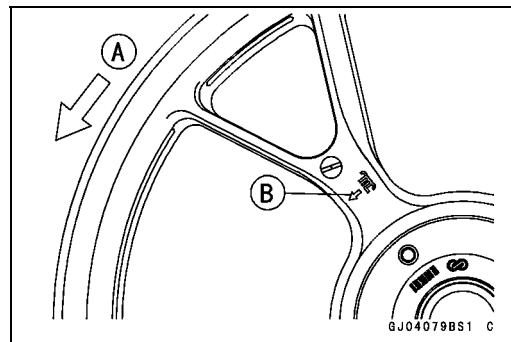

Wheels (Rims)

- Apply high-temperature grease to the grease seal lip.
- Fit the collars [A] on the both sides of the hub.
- The collars are identical.
- Insert the axle from the right side.
- Tighten the axle nut [B].
- Right Axle Clamp Bolts [C]
- Left Axle Clamp Bolts [D]
- Viewed from Rear [E]

Torque - Front Axle Nut: 127 N·m (13.0 kgf·m, 94 ft·lb)

- Before tightening the axle clamp bolts on the right front fork leg, pump the front fork up and down 4 or 5 times to all on the right front fork leg to seat on the front axle.

NOTE

○ Put a block in front of the front wheel to stop moving.

- Tighten the axle clamp bolts on the right fork leg first. Next, tighten the left axle clamp bolts.

Torque - Front Axle Clamp Bolts: 20 N·m (2.0 kgf·m, 15 ft·lb)

NOTE

○ Tighten the two clamp bolts alternately two times to ensure even tightening torque.

- Install the lower fairings (see Lower Fairing Installation in the Frame chapter).
- Install the front calipers (see Caliper Installation in the Brakes chapter).
- Check the front brake effectiveness (see Brake Operation Inspection in the Periodic Maintenance chapter).

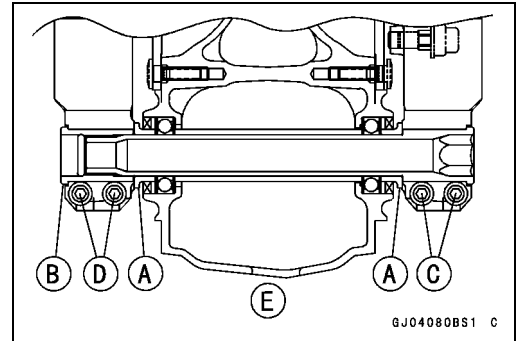

⚠ WARNING

Do not attempt to drive the motorcycle until a full brake lever is obtained by pumping the brake lever until the pads are against the disc. The brake will not function on the first application of the lever if this is not done.

Rear Wheel Removal

- Raise the rear wheel off the ground with the stand [A].

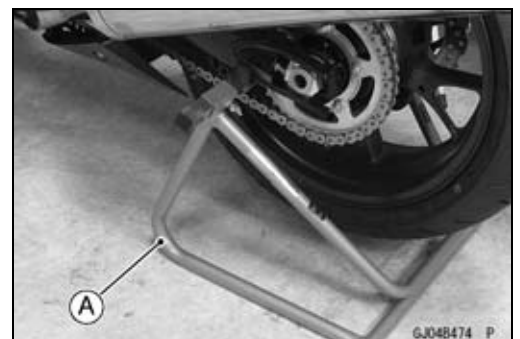

10-8 WHEELS/TIRES

Wheels (Rims)

- Remove:
 - Rear Caliper Mounting Bolts [A]
 - Rear Caliper [B]
- Remove the rear wheel rotation sensor from the caliper bracket (see Rear Wheel Rotation Sensor Removal in the Brakes chapter) (ZX1400B Models).

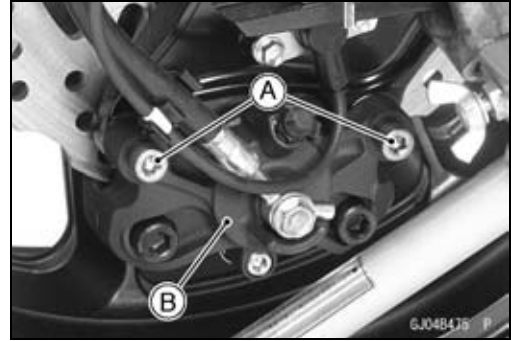

- Remove:
 - Cotter Pin [A]
 - Axle Nut [B]
 - Washer [C]
 - Axle [D] (from Left Side)

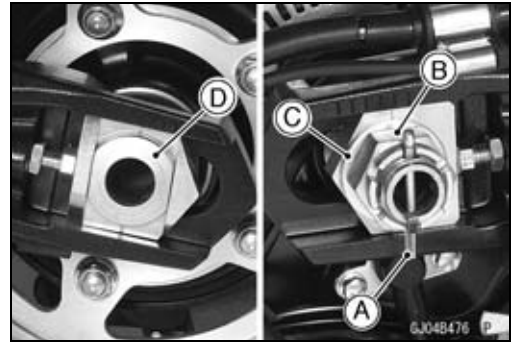

- Remove the drive chain [A] from the rear sprocket toward the left.
- Move the rear wheel back and remove it.



CAUTION

Do not lay the wheel on the ground with the disc facing down. This can damage or warp the disc. Place blocks under the wheel so that the disc does not touch the ground.

Rear Wheel Installation

- Apply high-temperature grease to the grease seal lips.
- Fit the collars on the both sides of the hub.
 - Right Side Collar [A]
 - Left Side Collar [B]

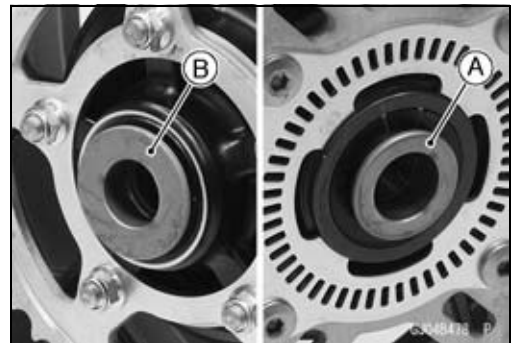

- Engage the drive chain with the rear sprocket.
- Install the caliper bracket [A] onto the swingarm stop [B].
- Insert the axle from the left side of the wheel, and tighten the axle nut.

Torque - Rear Axle Nut: 127 N·m (13.0 kgf·m, 94 ft·lb)

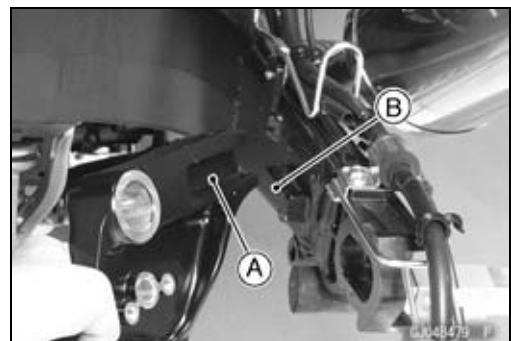

Wheels (Rims)

- Insert a new cotter pin [A].

NOTE

- When inserting the cotter pin, if the slots in the nut do not align with the cotter pin hole in the axle, tighten the nut clockwise [B] up to next alignment.
- It should be within 30°.
- Loosen once and tighten again when the slot goes past the nearest hole.

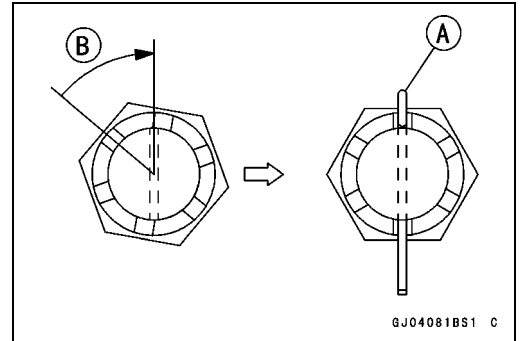

- Bend the cotter pin [A] over the nut.

⚠ WARNING

If the rear axle nut is not securely tightened or the cotter pin is not installed, an unsafe riding condition may result.

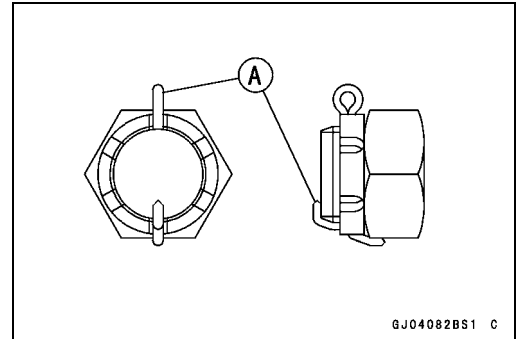

- Adjust the drive chain slack after installation (see Drive Chain Slack Inspection in the Periodic Maintenance chapter).
- Install the rear caliper (see Caliper Installation in the Brakes chapter).
- Install the rear wheel rotation sensor (see Rear Wheel Rotation Sensor Installation in the Brakes chapter) (ZX1400B Models).
- Check the rear brake effectiveness (see Brake Operation Inspection in the Periodic Maintenance chapter).

⚠ WARNING

Do not attempt to drive the motorcycle until a full brake pedal is obtained by pumping the brake pedal until the pads are against the disc. The brake will not function on the first application of the pedal if this is not done.

10-10 WHEELS/TIRES

Wheels (Rims)

Wheel Inspection

- Raise the front/rear wheel off the ground.

Special Tools - Jack: 57001-1238

Jack Attachment: 57001-1608

- Spin the wheel lightly, and check for roughness or binding.
- ★ If roughness or binding is found, replace the hub bearings (see Hub Bearing Removal/Installation).
- Inspect the wheel for small cracks, dents, bending, or warp.
- ★ If there is any damage to the wheel, replace the wheel.
- Remove the wheel, and support it with the tire by the axle.
- Measure the rim runout, axial [A] and radial [B], with a dial gauge.
- ★ If rim runout exceeds the service limit, check the hub bearings (see Hub Bearing Inspection).
- ★ If the problem is not due to the bearings, replace the wheel.

Rim Runout (with tire installed)

Standard:

Axial TIR 0.5 mm (0.02 in.) or less

Radial TIR 0.8 mm (0.03 in.) or less

Service Limit:

Axial TIR 1.0 mm (0.04 in.)

Radial TIR 1.0 mm (0.04 in.)

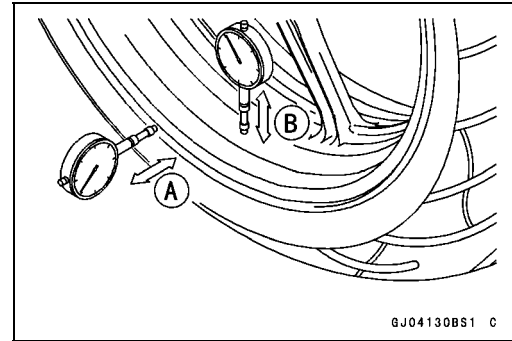

⚠ WARNING

Never attempt to repair a damaged wheel. If there is any damage besides wheel bearings, the wheel must be replaced to insure safe operational condition.

Axle Inspection

- Remove the front and rear axles (see Front/Rear Wheel Removal).
- Visually inspect the front and rear axle for damages.
- ★ If the axle is damaged or bent, replace it.
- Place the axle in V blocks that are 100 mm (3.94 in.) [A] apart, and set a dial gauge [B] on the axle at a point halfway between the blocks. Turn [C] the axle to measure the runout. The difference between the highest and lowest dial readings is the amount of runout.
- ★ If axle runout exceeds the service limit, replace the axle.

Axle Runout/100 mm (3.94 in.)

Standard: TIR 0.03 mm (0.0012 in.) or less

Service Limit: TIR 0.2 mm (0.01 in.)

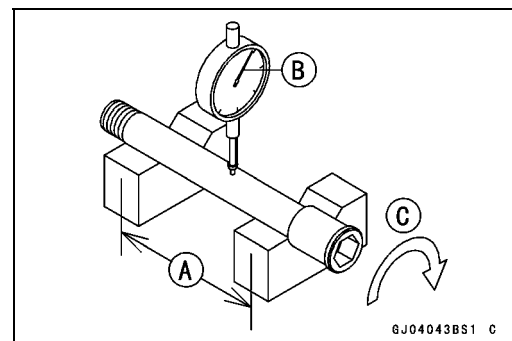

Wheels (Rims)

Balance Inspection

- Remove the front and rear wheels (see Front/Rear Wheel Removal).
- Support the wheel so that it can be spun freely.
- Spin the wheel lightly, and mark [A] the wheel at the top when the wheel stops.
- Repeat this procedure several times. If the wheel stops of its own accord in various positions, it is well balanced.
- ★ If the wheel always stops in one position, adjust the wheel balance (see Balance Adjustment).

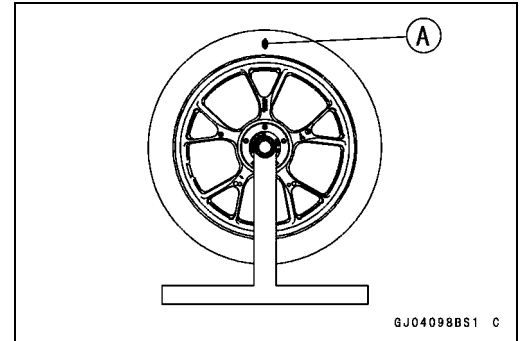

Balance Adjustment

- If the wheel always stops in one position, provisionally attach a balance weight [A] on the rim at the marking using adhesive tape.
- Rotate the wheel 1/4 turn [B], and see whether or not the wheel stops in this position. If it does, the correct balance weight is being used.
- ★ If the wheel rotates and the weight goes up, replace the weight with the next heavier size. If the wheel rotates and the weight goes down, replace the weight with the next lighter size. Repeat these steps until the wheel remains at rest after being rotated 1/4 turn.
- Rotate the wheel another 1/4 turn and then another 1/4 turn to see if the wheel is correctly balanced.
- Repeat the entire procedure as many times as necessary to achieve correct wheel balance.
- Permanently install the balance weight.

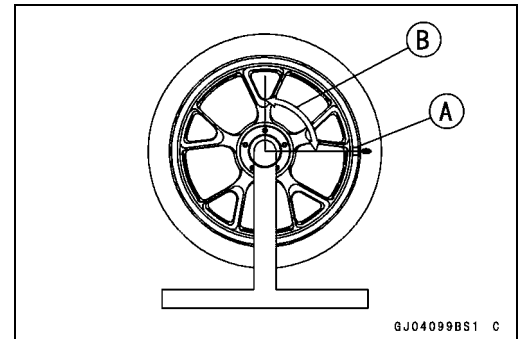

Balance Weight Removal

- Insert a regular tip screwdrivers [A] [B] between the rib [C] and weight [D] as shown.
- Pry the balance weight with two screwdrivers and remove the balance weight.
- Discard the used balance weight.

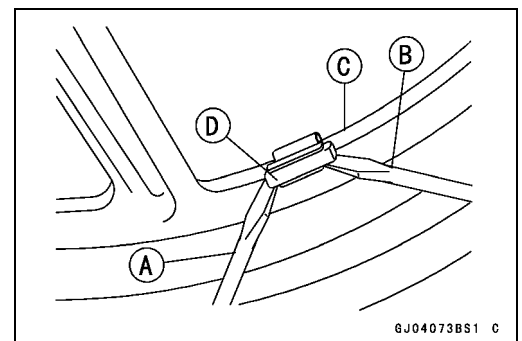

CAUTION

Do not tap the screwdrivers. The rim could be damaged.

10-12 WHEELS/TIRES

Wheels (Rims)

Balance Weight Installation

- Check if the weight portion has any play on the blade [A] and clip [B].
- ★ If it does, discard it.

⚠ WARNING

If the balance weight has any play on the rib of the rim, the blade and/or clip have been stretched. Replace the loose balance weight. Do not reuse used balance weight. Unbalanced wheels can create an unsafe riding condition.

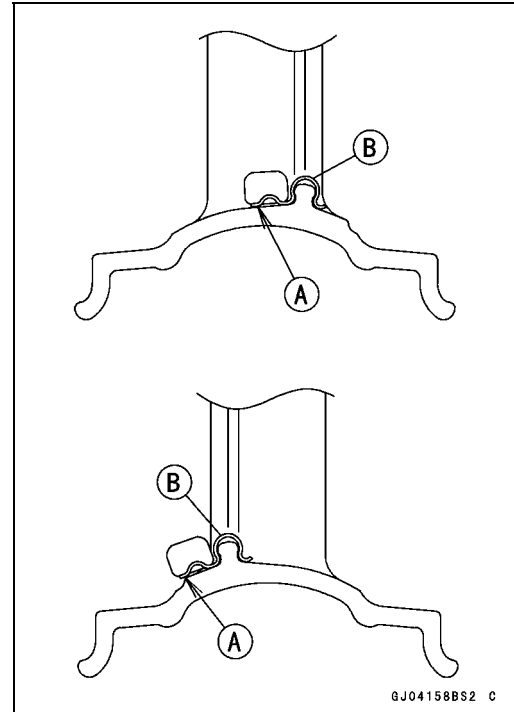

Balance Weight

Part Number	Weight
41075-0007	10 g (0.35 oz.)
41075-0008	20 g (0.71 oz.)
41075-0017	30 g (1.06 oz.)

NOTE

- Balance weights are available from Kawasaki dealers in 10, 20, and 30 grams (0.35 oz., 0.71 oz., and 1.06 oz.) sizes. An imbalance of less than 10 grams (0.35 oz.) will not usually affect running stability.
- Do not use four or more balance weight (more than 90 gram, 3.2 oz.). If the wheel requires an excess balance weight, disassemble the wheel to find the cause.

Wheels (Rims)

- Slip the balance weight [A] on to the rib [B], by pushing or lightly hammering [C] the clip [D].
- Install the balance weight at the left side of the motorcycle.
Left Side [E]
Right Side [F]

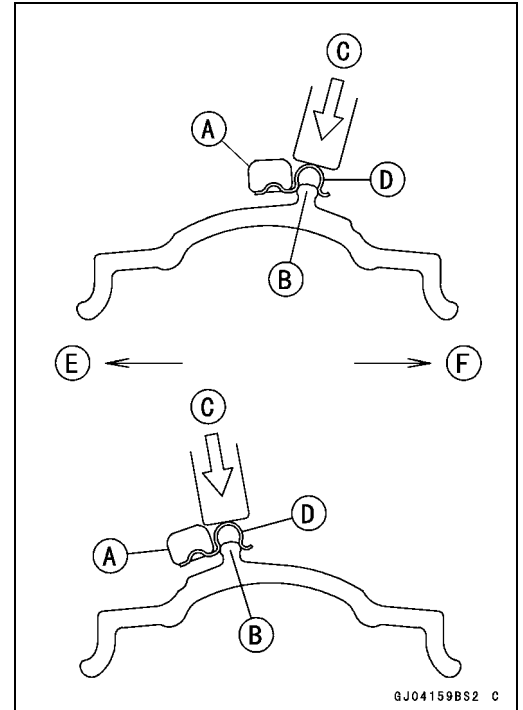

- Check that the blade [A] and clip [B] are fully seated on the rim [C] and that the clip is hooked over the rib [D].
Left Side [E]
Right Side [F]

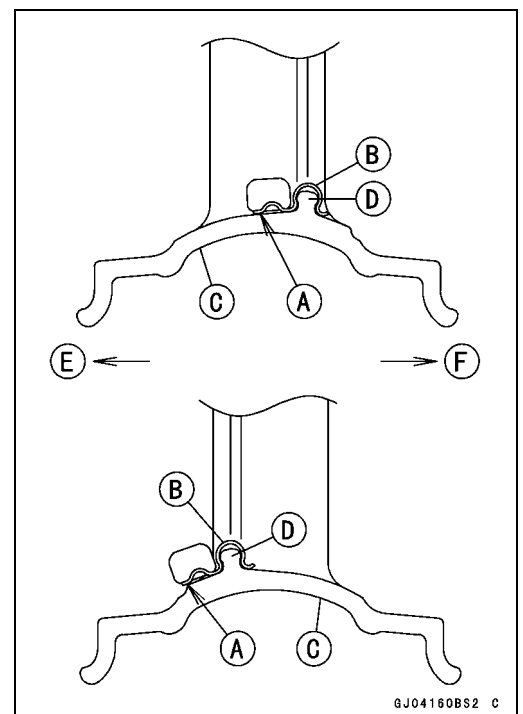

10-14 WHEELS/TIRES

Tires

Air Pressure Inspection/Adjustment

- Refer to the Air Pressure Inspection in the Periodic Maintenance chapter.

Tire Inspection

- Refer to the Wheel/Tire Damage Inspection in the Periodic Maintenance chapter.

Tire Removal

- Remove:
 - Wheel (see Front/Rear Wheel Removal)
 - Valve Core (Let out the air)
- To maintain wheel balance, mark the valve stem position on the tire with chalk so that the tire can be reinstalled in the same position.
 - Chalk Mark or Yellow Mark [A]
 - Air Valve [B]
 - Align [C]
- Lubricate the tire beads and rim flanges on both sides with a soap and water solution or rubber lubricant. This helps the tire beads slip off the rim flanges.

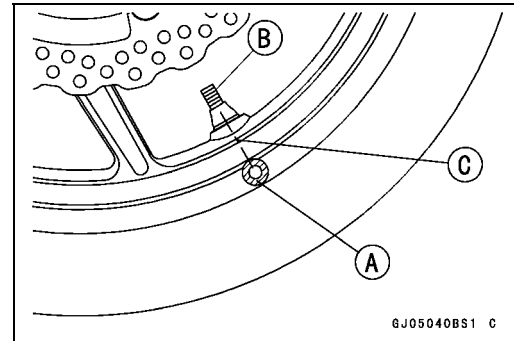

CAUTION

Never lubricate with engine oil or petroleum distillates because they will deteriorate the tire.

- Remove the tire from the rim using a suitable commercially available tire changer.

NOTE

○ *The tires cannot be removed with hand tools because they fit the rims too tightly.*

Tire Installation

⚠ WARNING

Use the same manufacturer's on both front and rear wheels.

- Inspect the rim and tire, and replace them if necessary.
- Clean the sealing surfaces of the rim and tire, and smooth the sealing surfaces of the rim with a fine emery cloth if necessary.
- Remove the air valve and discard it.

CAUTION

**Replace the air valve whenever the tire is replaced.
Do not reuse the air valve.**

Tires

- Install a new valve in the rim.
- Remove the valve cap, lubricate the stem seal [A] with a soap and water solution or rubber lubricant, and pull [B] the valve stem through the rim from the inside out until it snaps into place.

CAUTION

Do not use engine oil or petroleum distillates to lubricate the stem because they will deteriorate the rubber.

- The air valve is shown in the figure.

- Valve Cap [A]
- Valve Core [B]
- Stem Seal [C]
- Valve Stem [D]
- Valve Seat [E]
- Valve Opened [F]

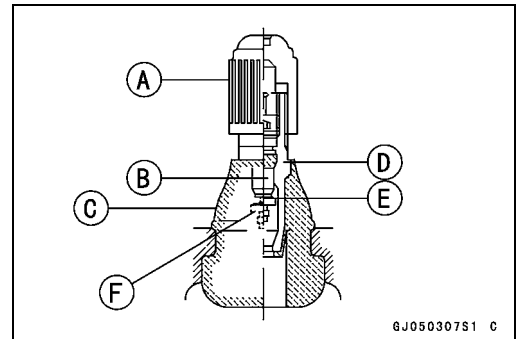
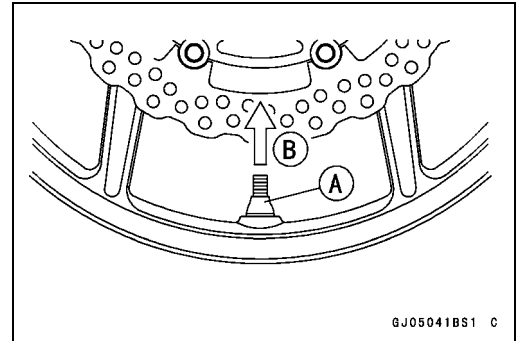

- Check the tire rotation mark on the front and rear tires and install them on the rim accordingly.

- Tire Rotation Mark [A]
- Rotating Direction [B]

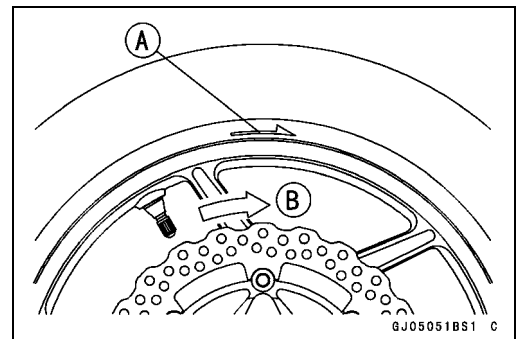

- Position the tire on the rim so that the valve [A] align with the tire balance mark [B] (the chalk mark made during removal, or the yellow paint mark on a new tire).
- Install the tire bead over the rim flange using a suitable commercially available tire changer.
- Lubricate the tire beads and rim flanges with a soap and water solution or rubber lubricant to help seat the tire beads in the sealing surfaces of the rim while inflating the tire.
- Center the rim in the tire beads, and inflate the tire with compressed air until the tire beads seat in the sealing surfaces.

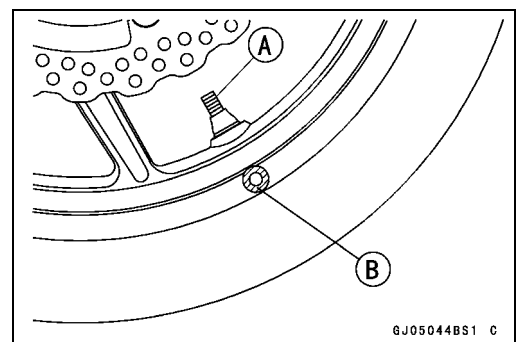

▲ WARNING

Be sure to install the valve core whenever inflating the tire, and do not inflate the tire to more than 400 kPa (4.0 kgf/cm², 57 psi). Overinflation can explode the tire with possibility of injury and loss of life.

10-16 WHEELS/TIRES

Tires

- Check to see that the rim lines [A] on both sides of the tire sidewalls are parallel with the rim flanges.
- ★ If the rim flanges and tire sidewall rim lines are not parallel, remove the valve core.
- Lubricate the rim flanges and tire beads.
- Install the valve core and inflate the tire again.
- After the tire beads seat in the rim flanges, check for air leakage.
- Inflate the tire slightly above standard inflation.
- Use a soap and water solution or submerge the tire, and check for bubbles that would indicate leakage.
- Adjust the air pressure to the specified pressure (see Air Pressure Inspection in the Periodic Maintenance chapter).
- Install the air valve cap.
- Adjust the wheel balance (see Balance Adjustment).

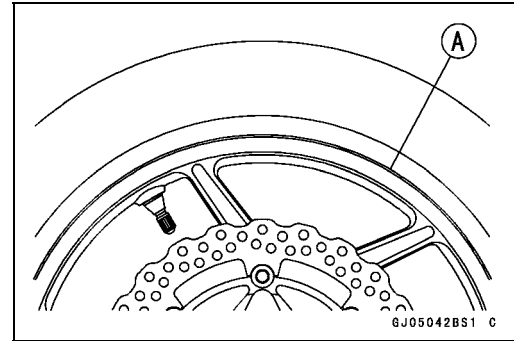

Tire Repair

Currently two types of repair for tubeless tires have come into wide use. One type is called a temporary (external) repair which can be carried out without removing the tire from the rim, and the other type is called permanent (internal) repair which requires tire removal. It is generally understood that higher running durability is obtained by permanent (internal) repairs than by temporary (external) ones. Also, permanent (internal) repairs have the advantage of permitting a thorough examination for secondary damage not visible from external inspection of the tire. For these reasons, Kawasaki does not recommend temporary (external) repair. Only appropriate permanent (internal) repairs are recommended. Repair methods may vary slightly from make to make. Follow the repair methods indicated by the manufacturer of the repair tools and materials so that safe results can be obtained.

Hub Bearing

Hub Bearing Removal

- Remove the wheel (see Front/Rear Wheel Removal), and take out the following.
 - Collars
 - Coupling (Out of rear hub)
 - Grease Seals
- Use the bearing remover to remove the hub bearing [A].

CAUTION

Do not lay the wheel on the ground with the disc facing down. This can damage or warp the disc. Place blocks under the wheel so that the disc does not touch the ground.

- Special Tools - Bearing Remover Head, $\phi 25 \times \phi 28$ [B]: 57001-1346
 Bearing Remover Shaft, $\phi 13$ [C]: 57001-1377

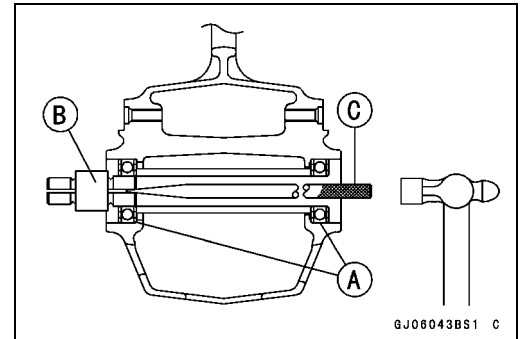

Hub Bearing Installation

- Before installing the hub bearings, blow any dirt or foreign particles out of the hub with compressed air to prevent contamination of the bearings.
- Replace the bearings with new ones.
- Install the bearings by using the bearing driver set which does not contact the bearing inner race.
- Press in each right the bearing [A] until they are bottomed.

Special Tool - Bearing Driver Set [B]: 57001-1129

- Replace the grease seals with new ones.
- Press in the grease seals [A] so that the seal surface is flush [B] with the end of the hole.
- Apply high-temperature grease to the grease seal lips.

Special Tool - Bearing Driver Set [C]: 57001-1129

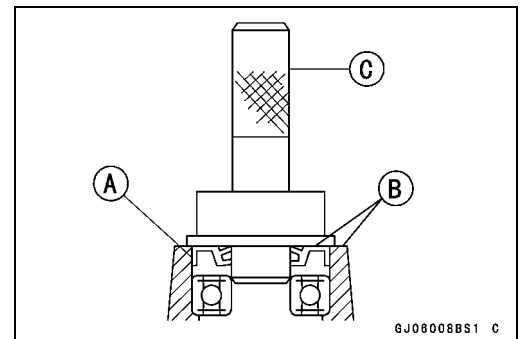
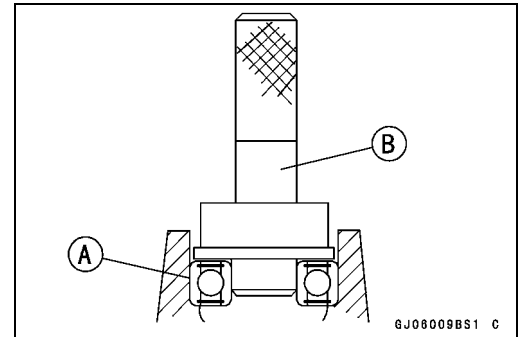

Hub Bearing Inspection

Since the hub bearings are made to extremely close tolerances, the clearance can not normally be measured.

NOTE

- Do not remove any bearings for inspection. If any bearings are removed, they will need to be replaced with new ones.
- Turn each bearing in the hub back and forth [A] while checking for plays, roughness, or binding.
- ★ If bearing play, roughness or binding is found, replace the bearing.
- Examine the bearing seal [B] for tears or leakage.
- ★ If the seal is torn or is leaking, replace the bearing.

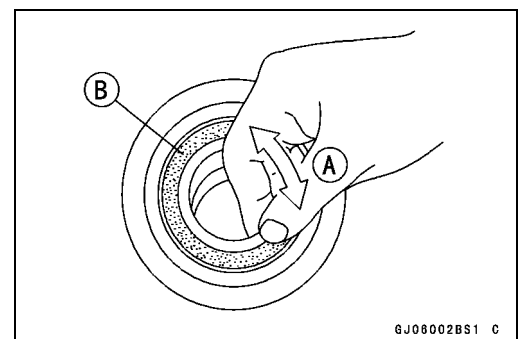

10-18 WHEELS/TIRES

Hub Bearing

Hub Bearing Lubrication

NOTE

- *Since the hub bearings are packed with grease and sealed, lubrication is not required.*

Final Drive

Table of Contents

Exploded View	11-2
Specifications	11-4
Special Tools	11-5
Drive Chain.....	11-6
Drive Chain Slack Inspection	11-6
Drive Chain Slack Adjustment	11-6
Wheel Alignment Inspection/Adjustment	11-6
Drive Chain Wear Inspection	11-6
Drive Chain Lubrication.....	11-6
Drive Chain Removal.....	11-6
Drive Chain Installation	11-6
Sprocket, Coupling	11-7
Engine Sprocket Removal	11-7
Engine Sprocket Installation	11-7
Rear Sprocket Removal.....	11-8
Rear Sprocket Installation.....	11-8
Coupling Installation.....	11-8
Coupling Bearing Removal	11-9
Coupling Bearing Installation	11-9
Coupling Bearing Inspection	11-10
Coupling Bearing Lubrication.....	11-10
Coupling Damper Inspection.....	11-10
Sprocket Wear Inspection.....	11-10
Rear Sprocket Warp Inspection	11-11

11-2 FINAL DRIVE

Exploded View

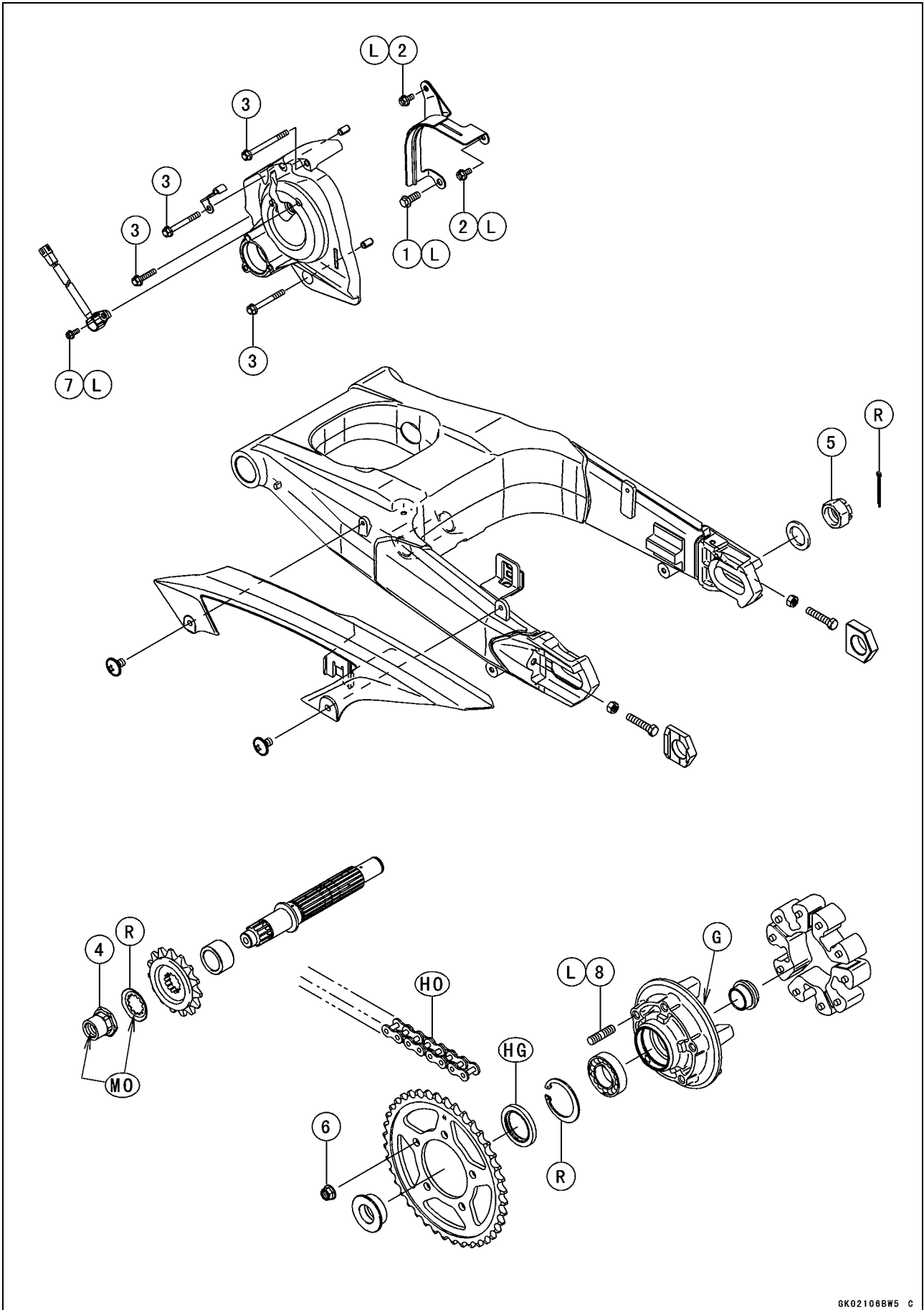

Exploded View

No.	Fastener	Torque			Remarks
		N·m	kgf·m	ft·lb	
1	Chain Guide Bolt	12	1.2	106 in·lb	L
2	Chain Guide Bolts	9.8	1.0	87 in·lb	L
3	Engine Sprocket Cover Bolts	9.8	1.0	87 in·lb	
4	Engine Sprocket Nut	125	13.0	92	MO
5	Rear Axle Nut	127	13.0	94	
6	Rear Sprocket Nuts	69	7.0	51	
7	Speed Sensor Bolt	3.9	0.40	35 in·lb	L
8	Stud Bolts	14.7	1.5	11	L

G: Apply grease.

HG: Apply high-temperature grease.

HO: Apply heavy oil.

L: Apply a non-permanent locking agent.

MO: Apply molybdenum disulfide oil solution.

(mixture of the engine oil and molybdenum disulfide grease in a weight ratio 10 : 1)

R: Replacement Parts

11-4 FINAL DRIVE

Specifications

Item	Standard	Service Limit
Drive Chain		
Drive Chain Slack	32 ~ 38 mm (1.3 ~ 1.5 in.)	---
Drive Chain Wear (20-link Length)	317.5 ~ 318.2 mm (12.50 ~ 12.53 in.)	323 mm (12.7 in.)
Standard Chain:		
Make	DAIDO	---
Type	DID50ZVM4 GC&B	---
Link	116 links	---
Sprockets		
Rear Sprocket Warp	0.4 mm (0.016 in.) or less	0.5 mm (0.020 in.)

Special Tools

Inside Circlip Pliers:
57001-143

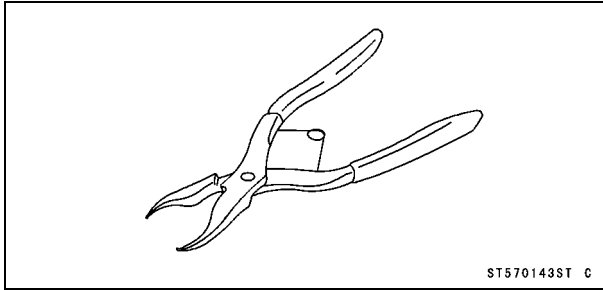

Bearing Driver Set:
57001-1129

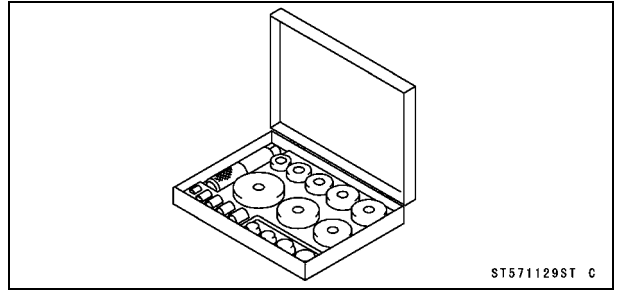

11-6 FINAL DRIVE

Drive Chain

Drive Chain Slack Inspection

- Refer to the Drive Chain Slack Inspection in the Periodic Maintenance chapter.

Drive Chain Slack Adjustment

- Refer to the Drive Chain Slack Adjustment in the Periodic Maintenance chapter.

Wheel Alignment Inspection/Adjustment

- Refer to the Wheel Alignment Inspection in the Periodic Maintenance chapter.

Drive Chain Wear Inspection

- Refer to the Drive Chain Wear Inspection in the Periodic Maintenance chapter.

Drive Chain Lubrication

- Refer to the Drive Chain Lubrication Condition Inspection in the Periodic Maintenance chapter.

Drive Chain Removal

- Remove the chain cover screws [A] and chain cover [B].
- Clear the chain cover from the swingarm.
- Remove:
 - Rear Wheel (see Rear Wheel Removal in the Wheels/Tires chapter)
 - Engine Sprocket (see Engine Sprocket Removal)
 - Swingarm (see Swingarm Removal in the Suspension chapter)
- Remove the drive chain [A] from the output shaft [B], and take it off the chassis.

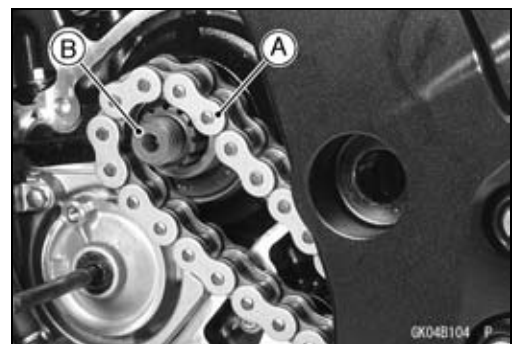
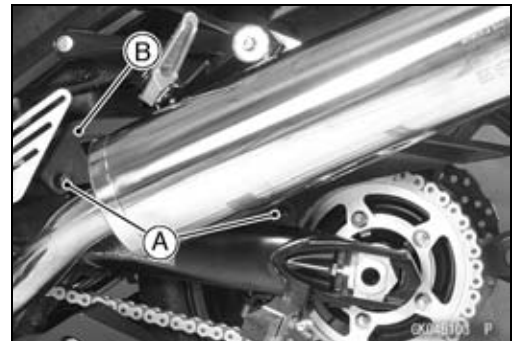

Drive Chain Installation

- Install the drive chain to the output shaft.
- Install:
 - Swingarm (see Swingarm Installation in the Suspension chapter)
 - Engine Sprocket (see Engine Sprocket Installation)
 - Rear Wheel (see Rear Wheel Installation in the Wheels/Tires chapter)
 - Chain Cover
- Adjust the drive chain slack after installing the chain (see Drive Chain Slack Adjustment in the Periodic Maintenance chapter).

Sprocket, Coupling

Engine Sprocket Removal

- Remove:
 - Left Lower Fairing (see Lower Fairing Removal in the Frame chapter)
 - Speed Sensor [A] (see Speed Sensor Removal in the Electrical System chapter)
 - Clutch Slave Cylinder [B] (see Clutch Slave Cylinder in the Clutch chapter)
 - Engine Sprocket Cover Bolts [C]
 - Engine Sprocket Cover [D]
- Flatten out the bended washer [A].
- Remove the engine sprocket nut [B].

NOTE

○When loosening the engine sprocket nut, hold the rear brake on.

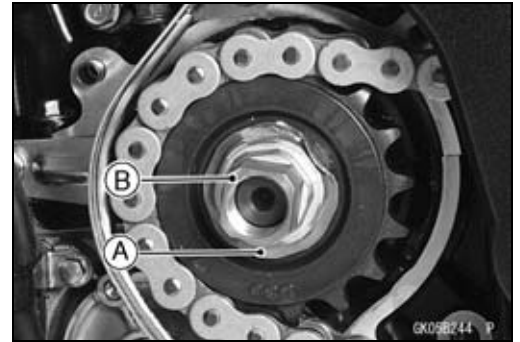
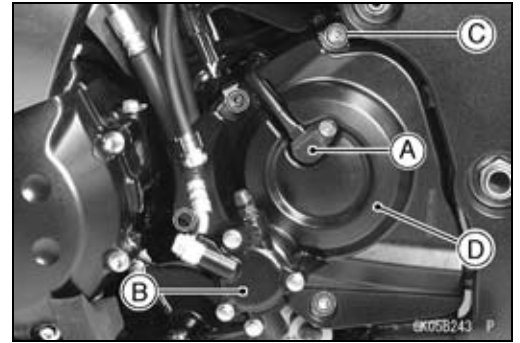

- Remove:
 - Washer [A]
 - Chain Guide Bolts [B]
 - Chain Guide [C]
- Raise the rear wheel off the ground with the stand.
- Remove the axle cotter pin, and loosen the rear axle nut.
- Loosen the both chain adjuster locknut to loosen the drive chain.
- Remove the drive chain from the rear sprocket toward the right.
- Pull the engine sprocket [D] with drive chain [E] off the output shaft [F].
- Disengage the drive chain from the engine sprocket.

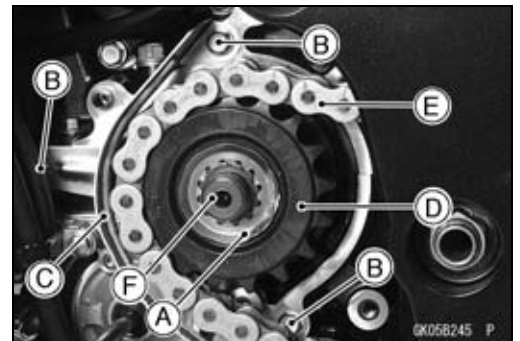

Engine Sprocket Installation

- Replace the sprocket washer and axle cotter pin.
- Install the engine sprocket onto the output shaft.
- Apply a non-permanent locking agent to the threads of the chain guide bolts.
- Install the chain guide, and tighten the bolts.
 - Torque - Chain Guide Bolt: 12 N·m (1.2 kgf·m, 106 in·lb)**
 - Chain Guide Bolts: 9.8 N·m (1.0 kgf·m, 87 in·lb)**
- Apply molybdenum disulfide oil solution to the threads of the output shaft and the seating surface of the engine sprocket nut.
- After torquing the engine sprocket nut, bend the one side of the washer [A] over the nut.



NOTE

○Tighten the nut while applying the rear brake.

Torque - Engine Sprocket Nut: 125 N·m (13.0 kgf·m, 92 ft·lb)

- Adjust the drive chain slack after installing the engine sprocket (see Drive Chain Slack Adjustment in the Periodic Maintenance chapter).

11-8 FINAL DRIVE

Sprocket, Coupling

- Install the engine sprocket cover.
- Install the clamp [A] as shown in the figure, and tighten the cover bolts.

Torque - Engine Sprocket Cover Bolts: 9.8 N·m (1.0 kgf·m, 87 in·lb)

- Bend the end of axle cotter pin surely after tightening the axle nut (see Rear Wheel Installation in the Wheels/Tires chapter).
- Install the removed parts (see appropriate chapters).

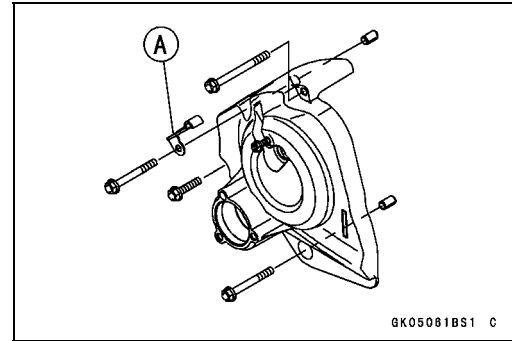

Rear Sprocket Removal

- Remove the rear wheel (see Rear Wheel Removal in the Wheels/Tires chapter).

CAUTION

Do not lay the wheel on the ground with the disc facing down. This can damage or warp the disc. Place blocks under the wheel so that the disc does not touch the ground.

- Remove the rear sprocket nuts [A].
- Remove the rear sprocket [B].

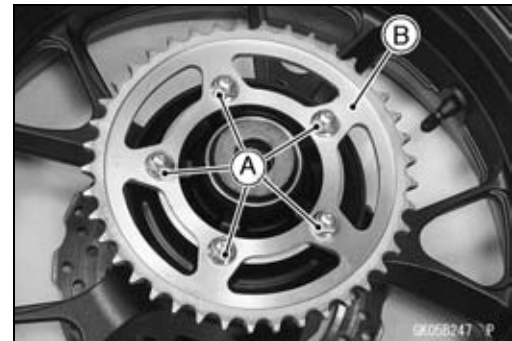

Rear Sprocket Installation

- Install the sprocket facing the tooth number marking [A] outward.
- Tighten the rear sprocket nuts.

Torque - Rear Sprocket Nuts: 69 N·m (7.0 kgf·m, 51 ft·lb)

- Install the rear wheel (see Rear Wheel Installation in the Wheels/Tires chapter).



Coupling Installation

- High-temperature grease the following.
 - Coupling Grease Seal Lips [A]
 - Coupling Internal Surface [B]

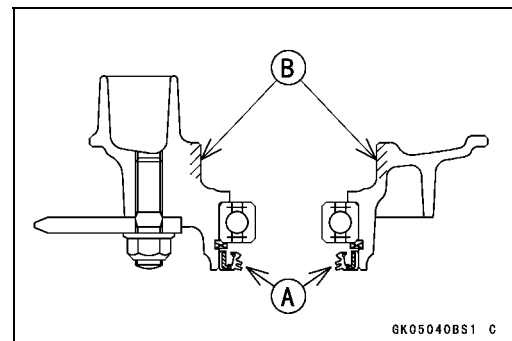

Sprocket, Coupling

- Install the collar [A].
- Install the coupling.



Coupling Bearing Removal

- Remove:
 - Coupling
 - Grease Seal
 - Circlip [A]

Special Tool - Inside Circlip Pliers: 57001-143

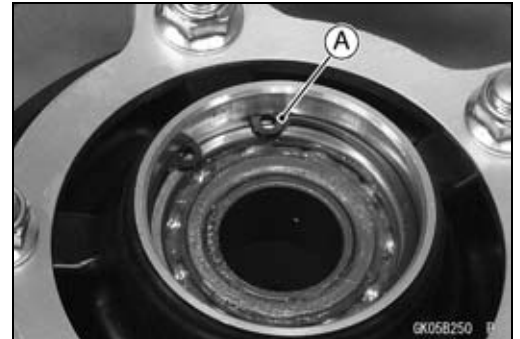

- Remove the bearing [A] by tapping from the wheel side.

Special Tool - Bearing Driver Set [B]: 57001-1129

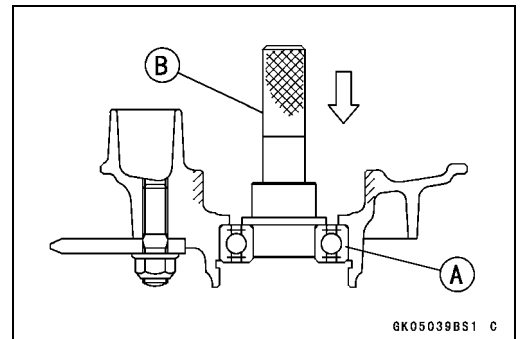

Coupling Bearing Installation

- Replace the bearing with a new one.

NOTE

○ Install the bearing so that the marked side faces out.

- Press in the bearing [A] until it is bottomed.

Special Tool - Bearing Driver Set [B]: 57001-1129

- Replace the circlip with a new one.

Special Tool - Inside Circlip Pliers: 57001-143

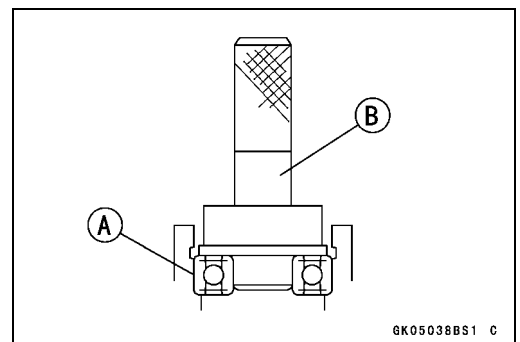

- Replace the grease seal with a new one.
- Press in the grease seal so that the seal surface is flush with the end of the hole.
- Apply high-temperature grease to the grease seal lips.

Special Tool - Bearing Driver Set: 57001-1129

11-10 FINAL DRIVE

Sprocket, Coupling

Coupling Bearing Inspection

Since the coupling bearing is made to extremely close tolerances, the clearance can not normally be measured.

NOTE

○It is not necessary to remove the coupling bearing for inspection. If the bearing is removed, it will need to be replaced with a new one.

- Turn the bearing in the coupling back and forth [A] while checking for plays, roughness or binding.
- ★ If the bearing play, roughness or binding is found, replace the bearing.
- Examine the bearing seal [B] for tears or leakage.
- ★ If the seal is torn or is leaking, replace the bearing.

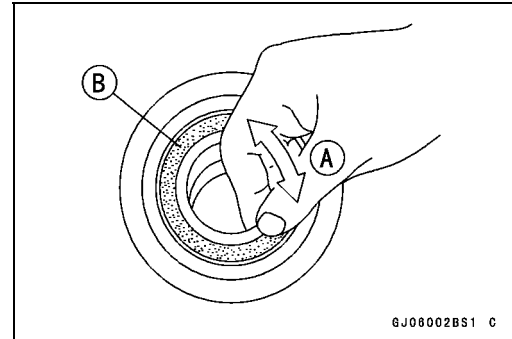

Coupling Bearing Lubrication

NOTE

○Since the coupling bearing is packed with grease and sealed, lubrication is not required.

Coupling Damper Inspection

- Remove the rear wheel coupling, and inspect the rubber dampers [A].
- Replace the damper if it appears damaged or deteriorated.

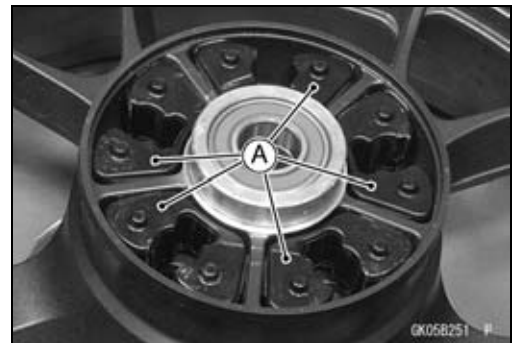

Sprocket Wear Inspection

- Visually inspect the engine and rear sprocket teeth for wear and damage.
- ★ If the teeth are worn as illustrated, replace the sprocket, and inspect the drive chain wear (see Drive Chain Wear Inspection in the Periodic Maintenance chapter).

Worn Tooth (Engine Sprocket) [A]

Worn Tooth (Rear Sprocket) [B]

Direction of Rotation [C]

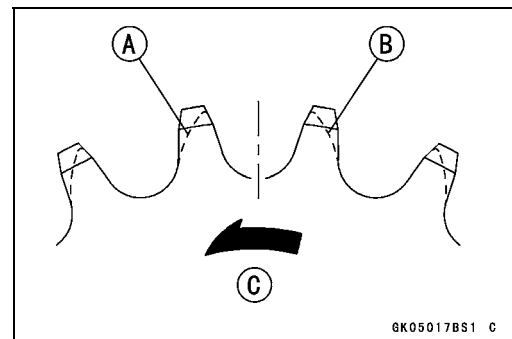

NOTE

○If a sprocket requires replacement, the chain is probably worn also. When replacing a sprocket, inspect the chain.

Sprocket, Coupling

Rear Sprocket Warp Inspection

- Raise the rear wheel off the ground with the stand so that it will turn freely.
- Set a dial gauge [A] against the rear sprocket [B] near the teeth as shown in the figure, and rotate [C] the rear wheel to measure the sprocket runout (warp). The difference between the highest and lowest dial gauge readings is the amount of runout (warp).
- ★ If the runout exceeds the service limit, replace the rear sprocket.

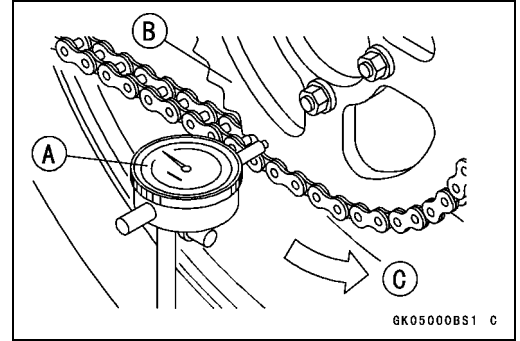

Rear Sprocket Warp

Standard:	0.4 mm (0.016 in.) or less
Service Limit:	0.5 mm (0.020 in.)

Brakes

Table of Contents

Exploded View	12-3
Specifications	12-12
Special Tools	12-13
Brake Lever, Brake Pedal.....	12-14
Brake Lever Position Adjustment.....	12-14
Brake Pedal Position Inspection	12-14
Brake Pedal Position Adjustment	12-14
Brake Pedal Removal	12-14
Brake Pedal Installation	12-15
Calipers	12-16
Front Caliper Removal.....	12-16
Rear Caliper Removal.....	12-16
Caliper Installation	12-17
Front Caliper Disassembly.....	12-17
Front Caliper Assembly.....	12-17
Rear Caliper Disassembly	12-17
Rear Caliper Assembly	12-17
Caliper Fluid Seal Damage.....	12-18
Caliper Dust Seal Damage	12-18
Caliper Piston and Cylinder Damage.....	12-19
Brake Pads.....	12-20
Front Brake Pad Removal.....	12-20
Front Brake Pad Installation.....	12-20
Rear Brake Pad Removal	12-21
Rear Brake Pad Installation	12-21
Brake Pad Wear Inspection	12-21
Master Cylinder	12-22
Front Master Cylinder Removal	12-22
Front Master Cylinder Installation	12-22
Rear Master Cylinder Removal.....	12-22
Rear Master Cylinder Installation.....	12-23
Front Master Cylinder Disassembly	12-23
Rear Master Cylinder Disassembly.....	12-23
Master Cylinder Assembly	12-23
Master Cylinder Inspection (Visual Inspection).....	12-23
Brake Disc	12-25
Brake Disc Removal	12-25
Brake Disc Installation	12-25
Brake Disc Wear	12-25
Brake Disc Warp	12-25
Brake Fluid	12-26
Brake Fluid Level Inspection.....	12-26
Brake Fluid Change	12-26
Brake Line Bleeding.....	12-26
Brake Hose.....	12-30
Brake Hose and Pipe Removal/Installation.....	12-30
Brake Hose and Pipe Inspection.....	12-30
Anti-Lock Brake System (Equipped Models).....	12-31
ABS Servicing Precautions.....	12-34
ABS Troubleshooting Outline.....	12-36

12-2 BRAKES

Inquiries to Rider.....	12-39
Self-diagnosis Outline.....	12-41
Self-diagnosis Procedures.....	12-41
Service Code Clearing Procedures.....	12-42
How to Read Service Codes.....	12-45
How to Erase Service Codes.....	12-45
ABS Indicator Light (LED) Inspection.....	12-47
ABS Indicator Light (LED) is Unlit (When the Ignition Switch turned to ON).....	12-47
ABS Indicator Light (LED) Lights (When the Motorcycle is Running, - No Service Code).....	12-48
Solenoid Valve Inspection (Service Code 13,14,17,18).....	12-48
ABS Solenoid Valve Relay Inspection (Service Code 19).....	12-48
Front, Rear Wheel Rotation Difference Abnormal (Service Code 25).....	12-50
ABS Pump Motor Relay Inspection (Service Code 35).....	12-50
Front Wheel Rotation Sensor Signal Abnormal (Service Code 42).....	12-51
Front Wheel Rotation Sensor Wiring Inspection (Service Code 43).....	12-52
Rear Wheel Rotation Sensor Signal Abnormal (Service Code 44).....	12-53
Rear Wheel Rotation Sensor Wiring Inspection (Service Code 45).....	12-54
Power Supply Voltage Abnormal (Under-Voltage) (Service Code 52).....	12-54
Power Supply Voltage Abnormal (Over-Voltage) (Service Code 53).....	12-55
ECU Inspection (Service Code 55).....	12-56
ABS Hydraulic Unit Removal.....	12-56
ABS Hydraulic Unit Installation.....	12-58
ABS Hydraulic Unit Inspection.....	12-59
Front Wheel Rotation Sensor Removal.....	12-59
Front Wheel Rotation Sensor Installation.....	12-59
Rear Wheel Rotation Sensor Removal.....	12-60
Rear Wheel Rotation Sensor Installation.....	12-60
Wheel Rotation Sensor Inspection.....	12-61
Wheel Rotation Sensor Air Gap Inspection.....	12-61
Wheel Rotation Sensor Rotor Inspection.....	12-62
ABS Solenoid Valve Relay Fuse (20 A) Removal.....	12-62
ABS Motor Relay Fuse (30 A) Removal.....	12-62
ABS ECU Fuse (10 A) Removal.....	12-62
Fuse Installation.....	12-63
Fuse Inspection.....	12-63

Exploded View

Dummy Page

12-4 BRAKES

Exploded View

ZX1400A Models

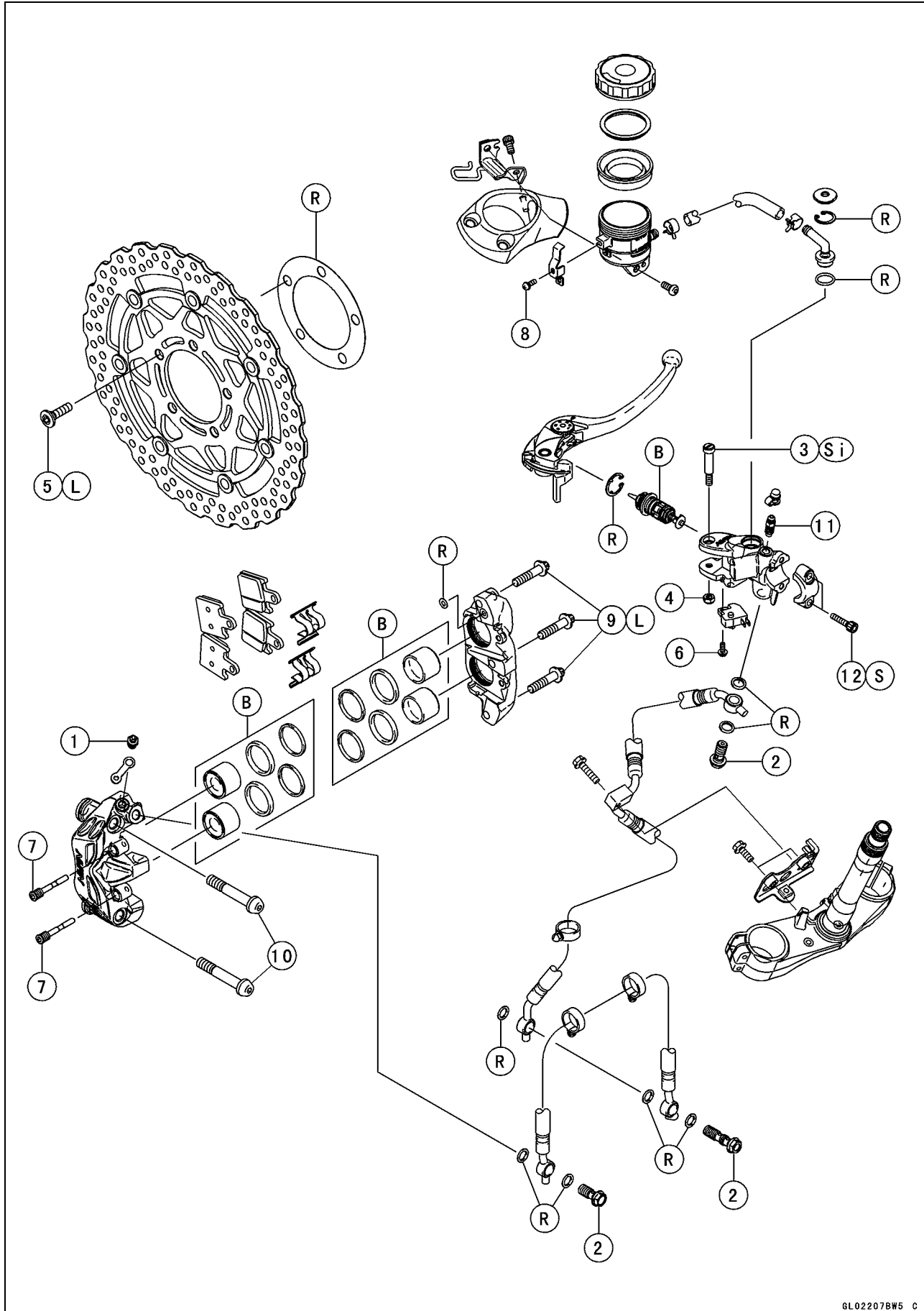

Exploded View

No.	Fastener	Torque			Remarks
		N·m	kgf·m	ft·lb	
1	Bleed Valves	7.8	0.80	69 in·lb	
2	Brake Hose Banjo Bolts	25	2.5	18	
3	Brake Lever Pivot Bolt	1.0	0.10	9 in·lb	Si
4	Brake Lever Pivot Bolt Locknut	5.9	0.60	52 in·lb	
5	Front Brake Disc Mounting Bolts	27	2.8	20	L
6	Front Brake Light Switch Screw	1.2	0.12	11 in·lb	
7	Front Brake Pad Pins	17.2	1.8	13	
8	Front Brake Reservoir Cap Stopper Screw	1.2	0.12	11 in·lb	
9	Front Caliper Assembly Bolts	27	2.8	20	L
10	Front Caliper Mounting Bolts	34	3.5	25	
11	Front Master Cylinder Bleed Valve	7.8	0.80	69 in·lb	
12	Front Master Cylinder Clamp Bolts	8.8	0.90	78 in·lb	S

B: Apply brake fluid.

L: Apply a non-permanent locking agent.

R: Replacement Parts

S: Follow the specified tightening sequence.

Si: Apply silicone grease (ex. PBC grease).

12-6 BRAKES

Exploded View

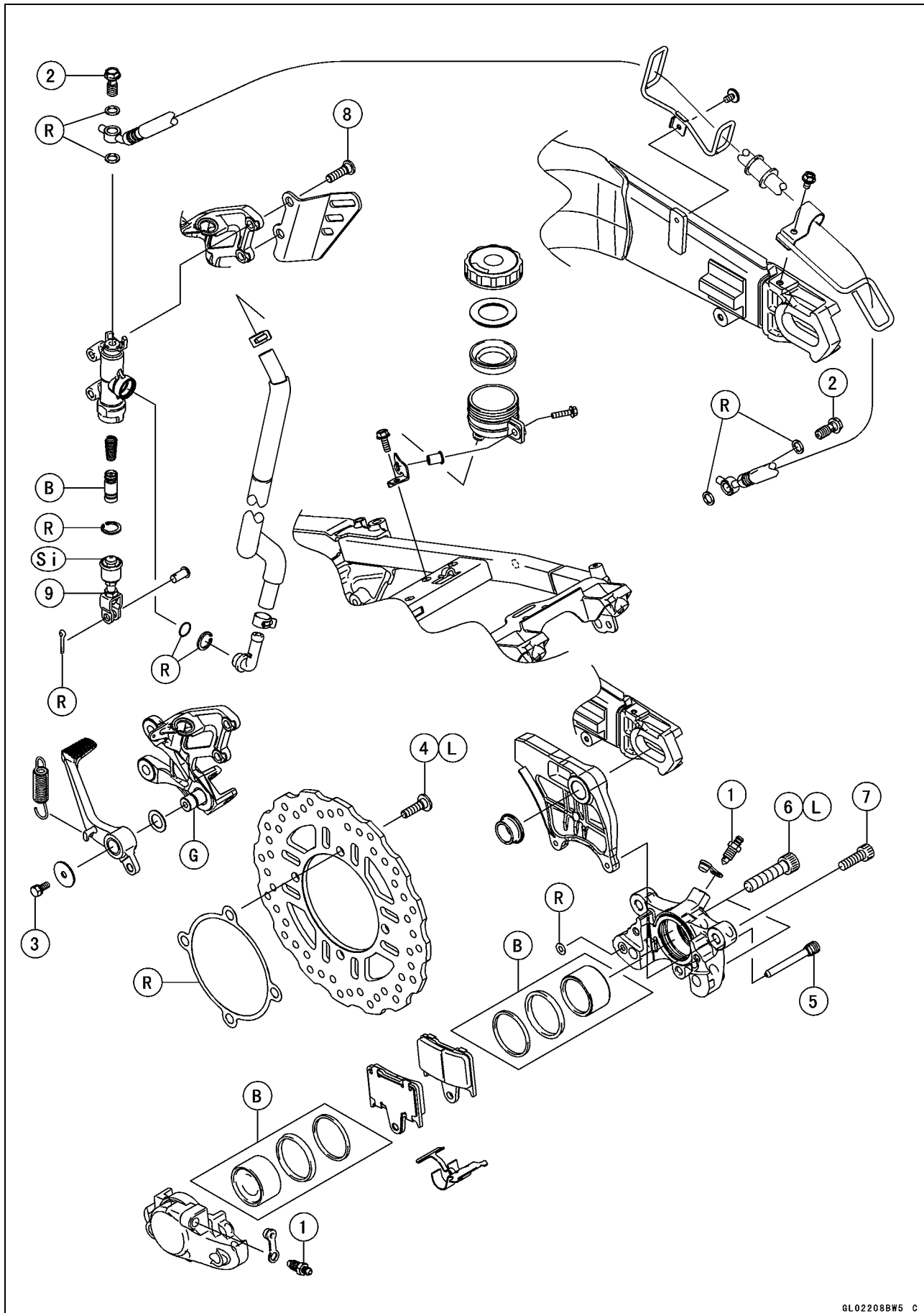

Exploded View

No.	Fastener	Torque			Remarks
		N·m	kgf·m	ft·lb	
1	Bleed Valves	7.8	0.80	69 in·lb	
2	Brake Hose Banjo Bolts	25	2.5	18	
3	Brake Pedal Bolt	8.8	0.90	78 in·lb	
4	Rear Brake Disc Mounting Bolts	27	2.5	18	L
5	Rear Brake Pad Pin	17.2	1.8	13	
6	Rear Caliper Assembly Bolts	37	3.8	27	L
7	Rear Caliper Mounting Bolts	25	2.5	18	
8	Rear Master Cylinder Mounting Bolts	25	2.5	18	
9	Rear Master Cylinder Push Rod Locknut	17.2	1.8	13	

B: Apply brake fluid.

G: Apply grease.

L: Apply a non-permanent locking agent.

R: Replacement Parts

Si: Apply silicone grease (ex. PBC grease).

12-8 BRAKES

Exploded View

ZX1400B Models

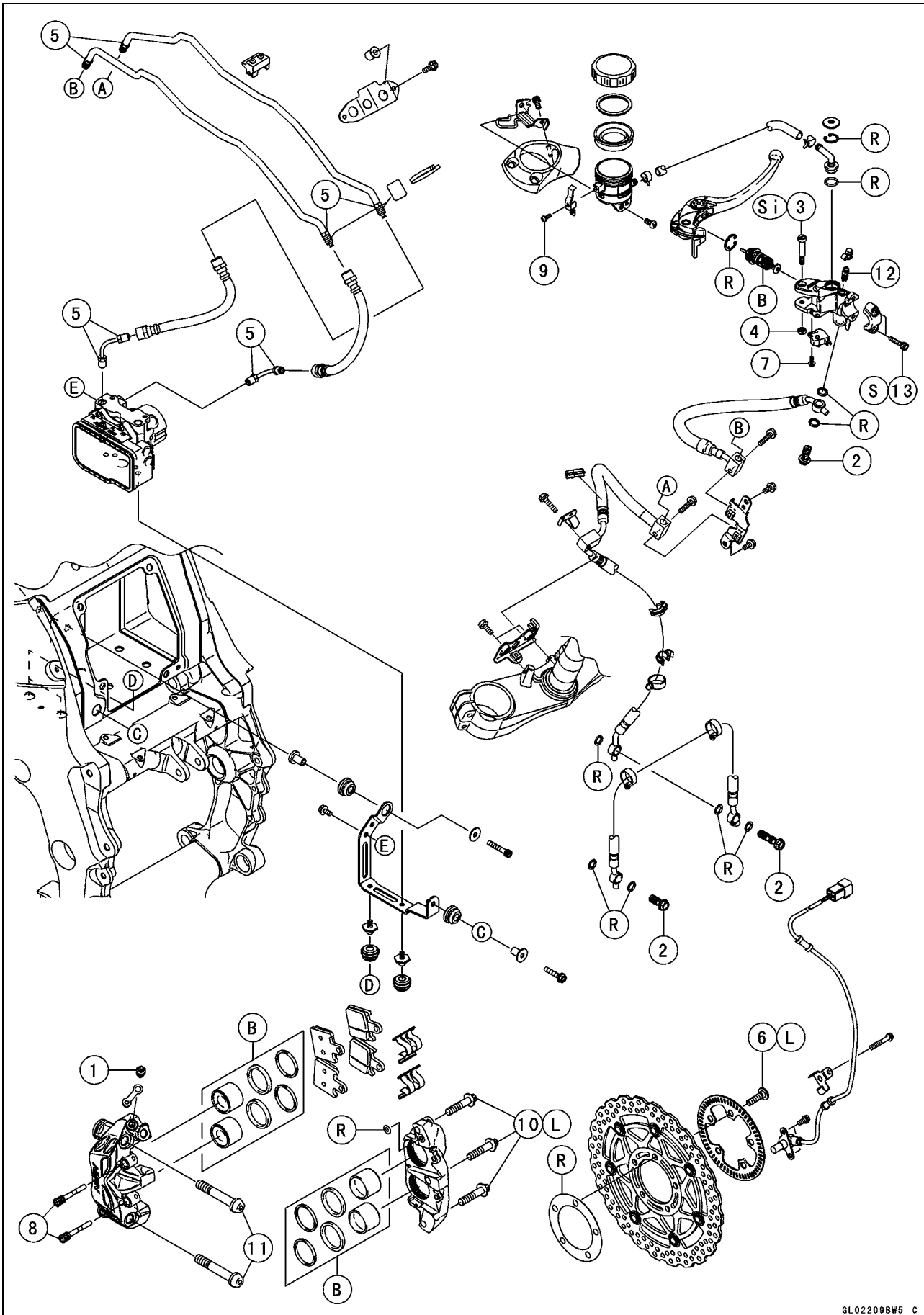

Exploded View

No.	Fastener	Torque			Remarks
		N·m	kgf·m	ft·lb	
1	Bleed Valves	7.8	0.80	69 in·lb	
2	Brake Hose Banjo Bolts	25	2.5	18	
3	Brake Lever Pivot Bolt	1.0	0.10	9 in·lb	Si
4	Brake Lever Pivot Bolt Locknut	5.9	0.60	52 in·lb	
5	Brake Pipe Joint Nuts	18	1.8	13	
6	Front Brake Disc Mounting Bolts	27	2.8	20	L
7	Front Brake Light Switch Screw	1.2	0.12	11 in·lb	
8	Front Brake Pad Pins	17.2	1.8	13	
9	Front Brake Reservoir Cap Stopper Screw	1.2	0.12	11 in·lb	
10	Front Caliper Assembly Bolts	27	2.8	20	L
11	Front Caliper Mounting Bolts	34	3.5	25	
12	Front Master Cylinder Bleed Valve	7.8	0.80	69 in·lb	
13	Front Master Cylinder Clamp Bolts	8.8	0.90	78 in·lb	S

B: Apply brake fluid.

L: Apply a non-permanent locking agent.

R: Replacement Parts

S: Follow the specified tightening sequence.

Si: Apply silicone grease (ex. PBC grease).

12-10 BRAKES

Exploded View

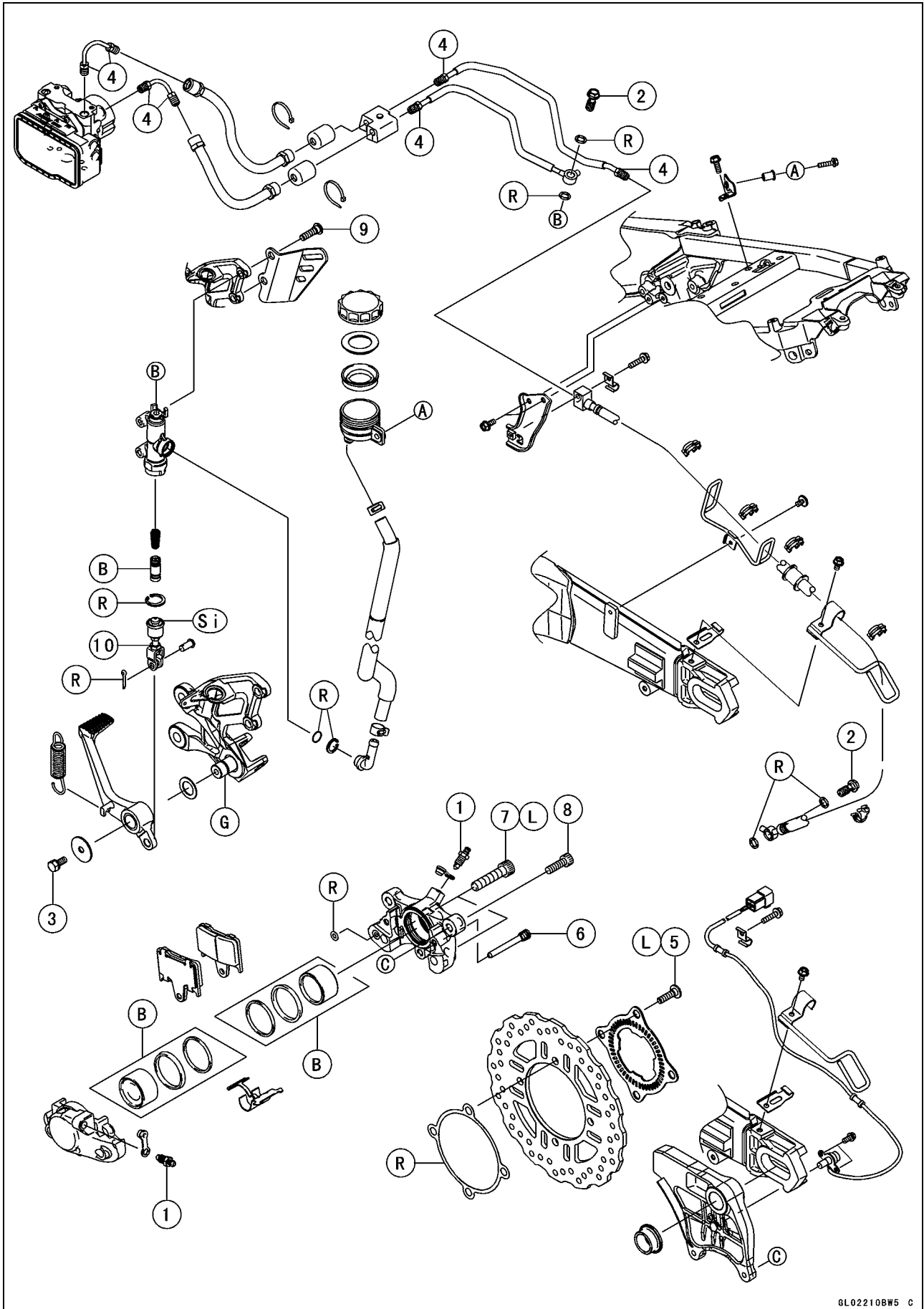

Exploded View

No.	Fastener	Torque			Remarks
		N·m	kgf·m	ft·lb	
1	Bleed Valves	7.8	0.80	69 in·lb	
2	Brake Hose Banjo Bolts	25	2.5	18	
3	Brake Pedal Bolt	8.8	0.90	78 in·lb	
4	Brake Pipe Joint Nuts	18	1.8	13	
5	Rear Brake Disc Mounting Bolts	27	2.8	20	L
6	Rear Brake Pad Pin	17.2	1.8	13	
7	Rear Caliper Assembly Bolts	37	3.8	27	L
8	Rear Caliper Mounting Bolts	25	2.5	18	
9	Rear Master Cylinder Mounting Bolts	25	2.5	18	
10	Rear Master Cylinder Push Rod Locknut	17.2	1.8	13	

B: Apply brake fluid.

G: Apply grease.

L: Apply a non-permanent locking agent.

R: Replacement Parts

Si: Apply silicone grease (ex. PBC grease).

12-12 BRAKES

Specifications

Item	Standard	Service Limit
Brake Lever, Brake Pedal		
Brake Lever Position	6-way adjustable (to suit rider)	— — —
Brake Lever Free Play	Non-adjustable	— — —
Pedal Free Play	Non-adjustable	— — —
Pedal Position	About 45 mm (1.8 in.) below footpeg top	— — —
Brake Pads		
Lining Thickness:		
Front	4.0 mm (0.16 in.)	1 mm (0.04 in.)
Rear	5.0 mm (0.20 in.)	1 mm (0.04 in.)
Brake Discs		
Thickness:		
Front	4.8 ~ 5.2 mm (0.19 ~ 0.20 in.)	4.5 mm (0.18 in.)
Rear	5.8 ~ 6.2 mm (0.23 ~ 0.24 in.)	5.5 mm (0.22 in.)
Runout	TIR 0.15 mm (0.006 in.) or less	TIR 0.3 mm (0.01 in.)
Brake Fluid		
Grade	DOT4	— — —

Special Tools

Inside Circlip Pliers:
57001-143

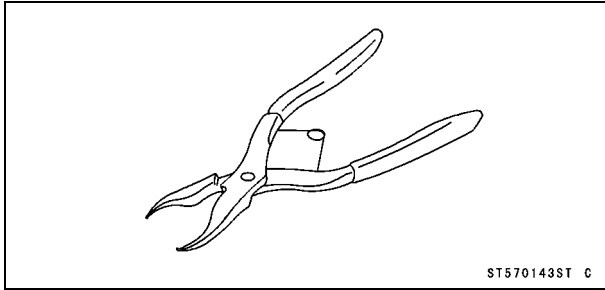

Hand Tester:
57001-1394

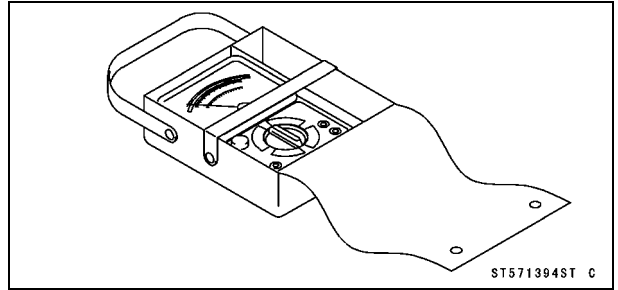

Jack:
57001-1238

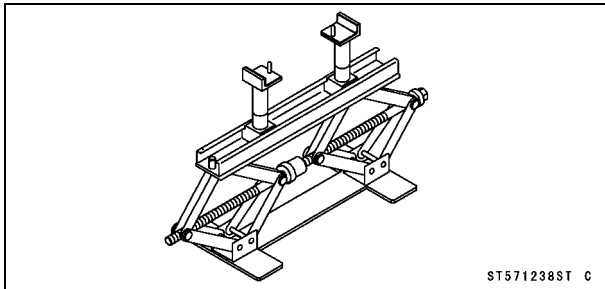

Jack Attachment:
57001-1608

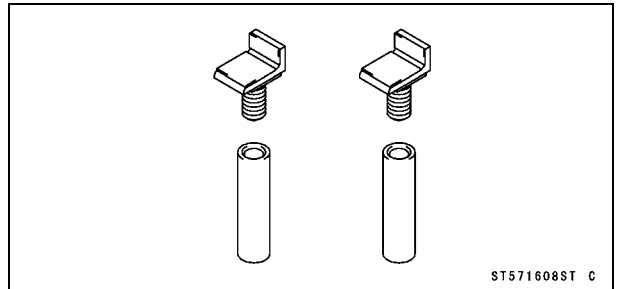

12-14 BRAKES

Brake Lever, Brake Pedal

Brake Lever Position Adjustment

The brake lever adjuster has 6 positions so that the brake lever position can be adjusted to suit the operator's hand.

- Push the lever forward and turn the adjuster [A] to align the number with the arrow mark [B] on the lever holder.
- The distance from the grip to the lever is minimum at number 6 and maximum at number 1.

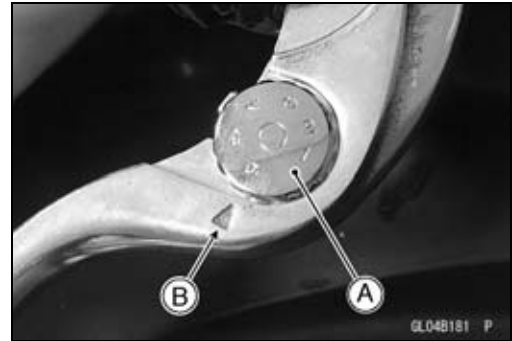

Brake Pedal Position Inspection

- Check that the brake pedal [A] is in the correct position. Footpeg [B]

Pedal Position

Standard: About 45 mm (1.8 in.) [C] below top of footpeg

- ★ If it is incorrect, adjust the brake pedal position.

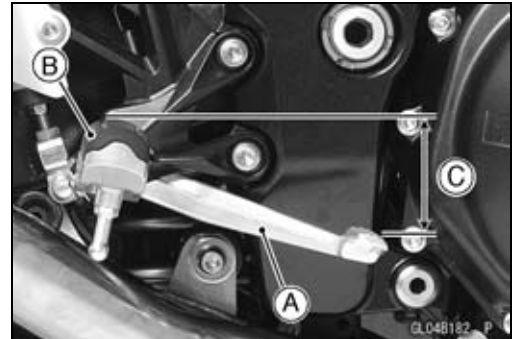

Brake Pedal Position Adjustment

NOTE

○ Usually it is not necessary to adjust the pedal position, but always adjust it when push rod locknut has been loosened.

- Loosen the locknut [A] and turn the push rod with the hex head [B] to achieve the correct pedal position.
- ★ If the length [C] shown is 80 ± 1 mm (3.1 ± 0.04 in.), the pedal position will be within the standard range.
- Tighten:

Torque - Rear Master Cylinder Push Rod Locknut: 17.2 N·m (1.8 kgf·m, 13 ft·lb)

- Check the brake light switch operation (see Brake Light Switch Operation Inspection in the Periodic Maintenance chapter).

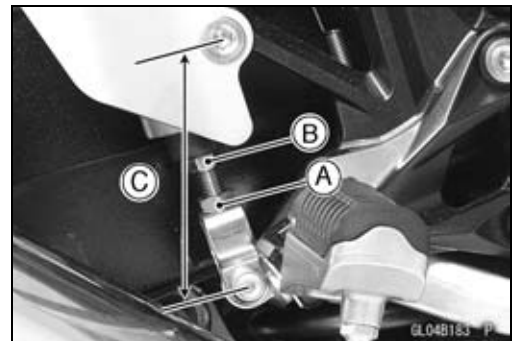

Brake Pedal Removal

- Remove:
 - Rear Master Cylinder Mounting Bolts [A]
 - Right Footpeg Bracket Bolts [B]



Brake Lever, Brake Pedal

- Remove:
 - Cotter Pin [A]
 - Joint Pin [B]
 - Rear Brake Light Switch Spring [C]
 - Return Spring [D]
- Remove the mounting bolt [E] and take out the brake pedal.

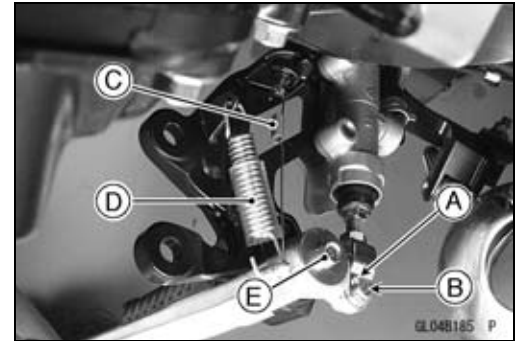

Brake Pedal Installation

- Apply grease to the pivot shaft [A] and install the washer [B].
- Install:
 - Brake Pedal [C]
 - Washer [D]
 - Brake Pedal Bolt [E]

Torque - Brake Pedal Bolt: 8.8 N·m (0.90 kgf·m, 78 in·lb)

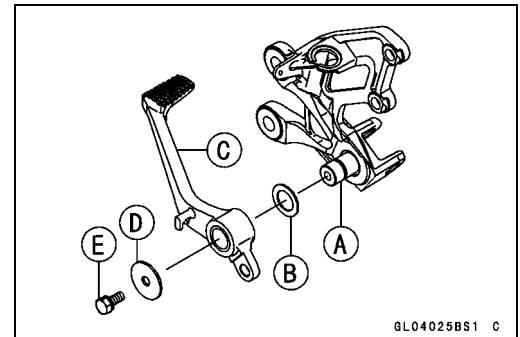

- Hook the lower end of the rear brake light switch spring [A] on the pedal hook.
- Hook the upper end of the return spring [B] on the pedal hook.

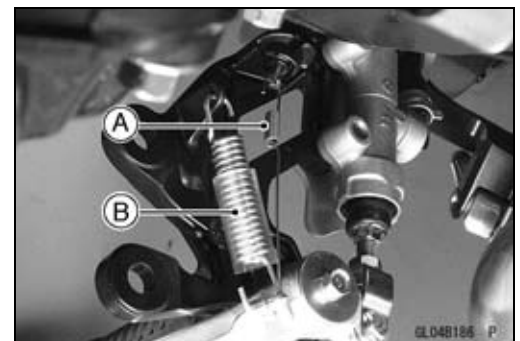

- Replace the cotter pin with a new one.
- Insert the cotter pin [A] and bend the pin ends [B].

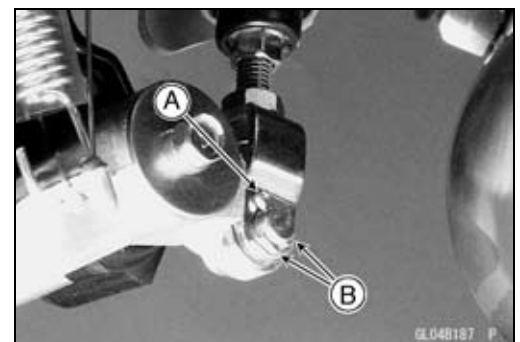

- Install the right footpeg bracket.
 - Torque - Front Footpeg Bracket Bolts: 25 N·m (2.5 kgf·m, 18 ft·lb)**
- Depress the brake pedal [A] and then align the bolts holes of the master cylinder [B].
 - Torque - Rear Master Cylinder Mounting Bolts: 25 N·m (2.5 kgf·m, 18 ft·lb)**
- Check the brake pedal position (see Brake Pedal Position Inspection).

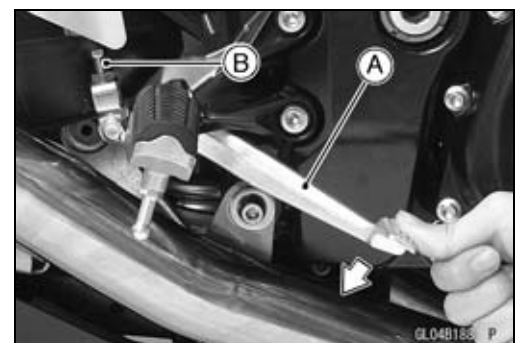

12-16 BRAKES

Calipers

Front Caliper Removal

- Loosen the banjo bolt [A] at the brake hose lower end, and tighten it loosely.
- Unscrew the caliper mounting bolts [B], and detach the caliper [C] from the disc.

CAUTION

Do not loosen the caliper assembly bolts. Take out only the caliper mounting bolts for caliper removal. Loosening the caliper assembly bolts will cause brake fluid leakage.

- Unscrew the banjo bolt and remove the brake hoses [D] from the caliper (see Brake Hose Removal/Installation).

CAUTION

Immediately wash away any brake fluid that spills.

NOTE

○If the caliper is to be disassembled after removal and if compressed air is not available, disassemble the caliper before the brake hose is removed (see Front Caliper Disassembly).

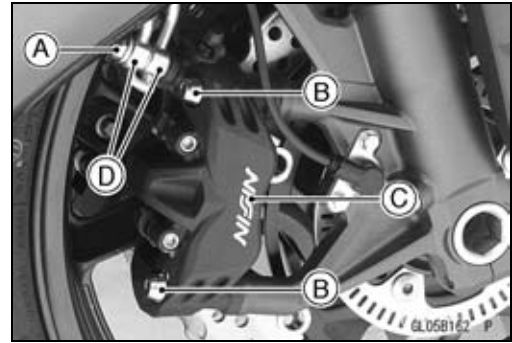

Rear Caliper Removal

- Loosen the banjo bolt [A] at the brake hose lower end, and tighten it loosely.
- Unscrew the caliper mounting bolts [B], and detach the caliper [C] from the disc.

CAUTION

Do not loosen the caliper assembly bolts. Take out only the caliper mounting bolts for caliper removal. Loosening the caliper assembly bolts will cause brake fluid leakage.

- Unscrew the banjo bolt and remove the brake hose [D] from the caliper (see Brake Hose Removal/Installation).

CAUTION

Immediately wash away any brake fluid that spills.

NOTE

○If the caliper is to be disassembled after removal and if compressed air is not available, disassemble the caliper before the brake hose is removed (see Rear Caliper Disassembly).

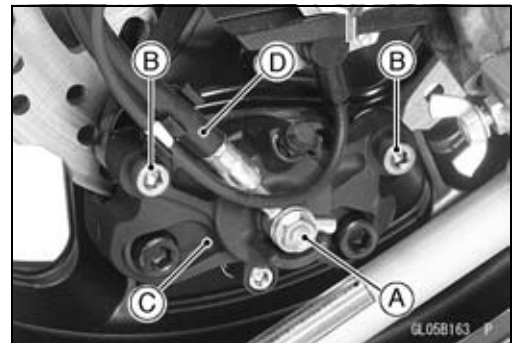

Calipers

Caliper Installation

- Install the caliper and brake hose lower end.
- Replace the washers on each side of hose fitting with new ones.
- Tighten:

Torque - Caliper Mounting Bolts

Front: 34 N·m (3.5 kgf·m, 25 ft·lb)

Rear: 25 N·m (2.5 kgf·m, 18 ft·lb)

Brake Hose Banjo Bolts: 25 N·m (2.5 kgf·m, 18 ft·lb)

- Check the fluid level in the brake reservoirs.
- Bleed the brake line (see Brake Line Bleeding).
- Check the brake for good braking power, no brake drag, and no fluid leakage.

⚠ WARNING

Do not attempt to drive the motorcycle until a full brake lever or pedal is obtained by pumping the brake lever or pedal until the pads are against the disc. The brakes will not function on the first application of the lever or pedal if this is not done.

Front Caliper Disassembly

- Refer to the Caliper Rubber Parts Replacement in the Periodic Maintenance chapter.

Front Caliper Assembly

- Refer to the Caliper Rubber Parts Replacement in the Periodic Maintenance chapter.

Rear Caliper Disassembly

- Refer to the Caliper Rubber Parts Replacement in the Periodic Maintenance chapter.

Rear Caliper Assembly

- Refer to the Caliper Rubber Parts Replacement in the Periodic Maintenance chapter.

12-18 BRAKES

Calipers

Caliper Fluid Seal Damage

The fluid seal (piston seal) [A] is placed around the piston to maintain clearance between the pad and the disc. If the seal is in a poor condition, it could lead the pad to wear excessively or the brake to drag, which may cause the temperature of the discs or the brake fluid to increase.

- Replace the fluid seal if it exhibits any of the conditions listed below.
 - Brake fluid leakage around the pad.
 - Brakes overheat.
 - Considerable difference in inner and outer pad wear.
 - Seal and piston are stuck together.
- ★ If the fluid seal is replaced, replace the dust seal [B] as well. Also, replace all seals every other time the pads are changed.

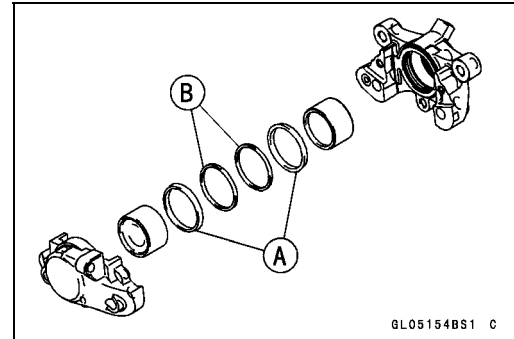
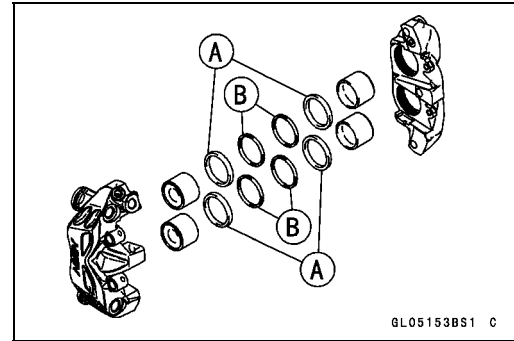

Caliper Dust Seal Damage

- Check that the dust seals [A] are not cracked, worn, swollen, or otherwise damaged.
- ★ If they show any damage, replace the dust seals with new ones.
 - Pistons [B]
 - Fluid Seals [C]

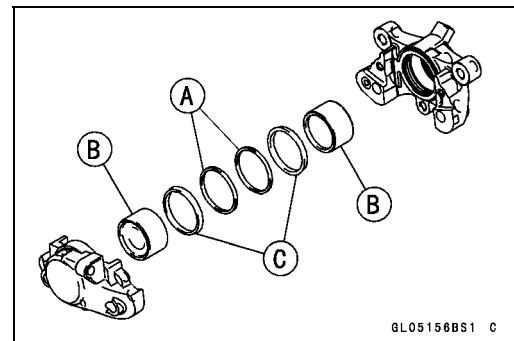
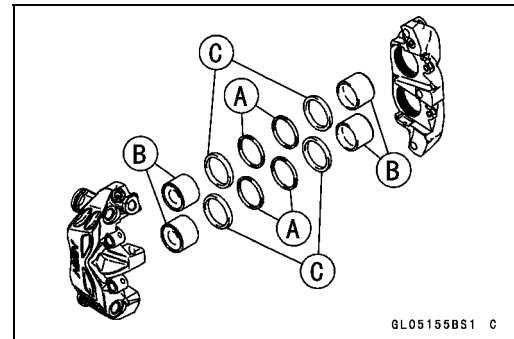

Calipers

Caliper Piston and Cylinder Damage

- Visually inspect the pistons [A] and cylinder surfaces [B].
- ★ Replace the caliper if the cylinder and piston are badly scored or rusty.

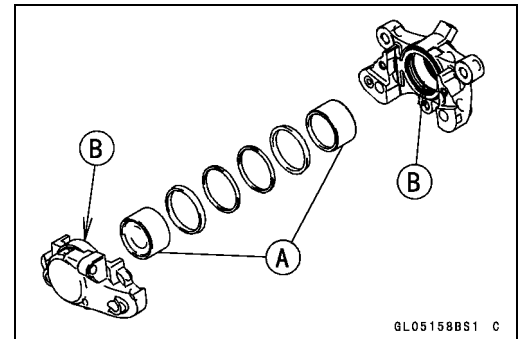
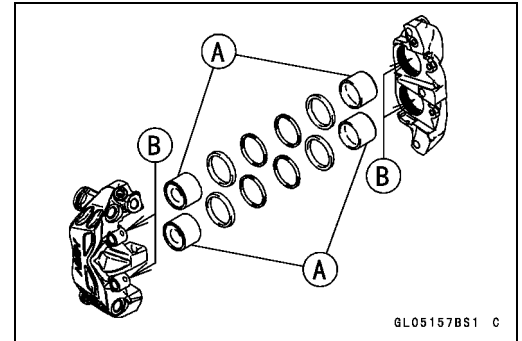

12-20 BRAKES

Brake Pads

Front Brake Pad Removal

- Loosen the pad pins [A].



- Remove:
 - Pad Pins [A]
 - Pad Springs [B]
 - Brake Pads [C]

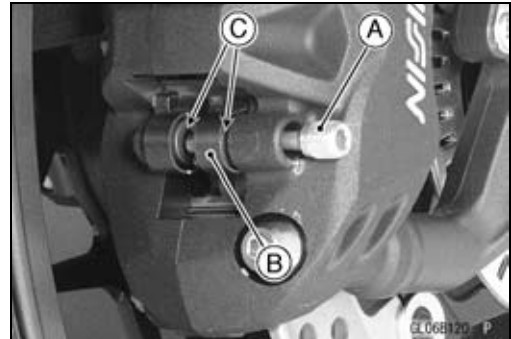

Front Brake Pad Installation

- Push the caliper pistons in by hand as far as they will go.
- Install the outside pad [A] and insert the pad pin [B] as shown in the figure.

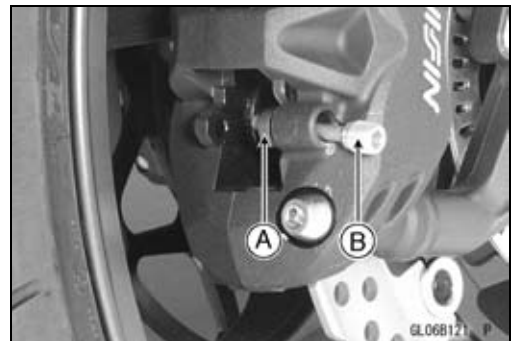

- Set:
 - Inside Pad [A]
 - Pad Spring [B]
- Pushing the pin holder [C] to hole of the pad and insert the pad pin.

Torque - Front Brake Pad Pins: 17.2 N·m (1.8 kgf·m, 13 ft·lb)

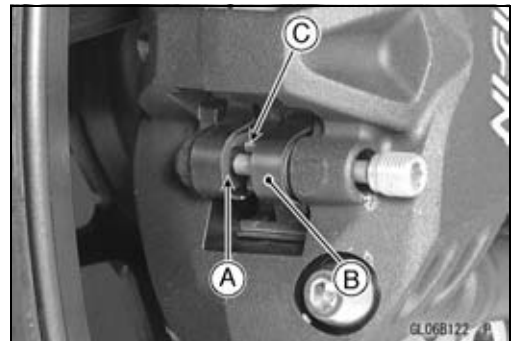

⚠ WARNING

Do not attempt to drive the motorcycle until a full brake lever is obtained by pumping the brake lever and the pads are against the disc. The brake will not function on the first application of the lever if this is not done.

Brake Pads

Rear Brake Pad Removal

- Loosen the pad pin [A].
- Unscrew the caliper mounting bolts [B].
- Remove the caliper with the hose installed.

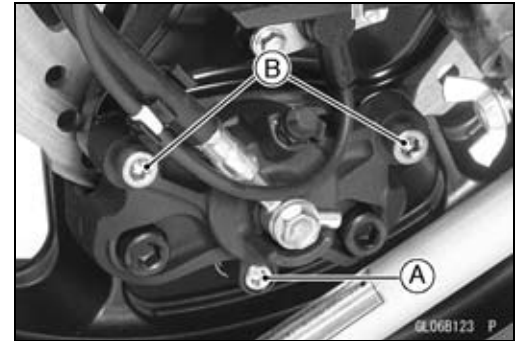

- Remove:
 - Pad Pin [A]
 - Pad Spring [B]
 - Brake Pads [C]

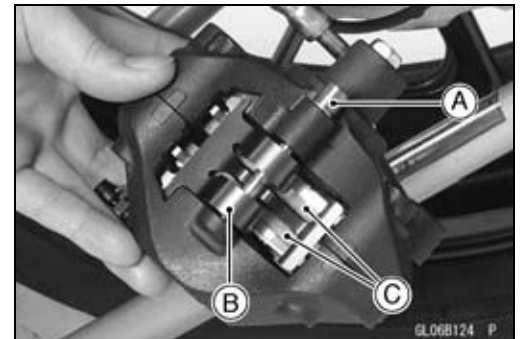

Rear Brake Pad Installation

- Push the caliper pistons in by hand as far as they will go.
- Install the outside pad [A] and insert the pad pin [B] as shown in the figure.

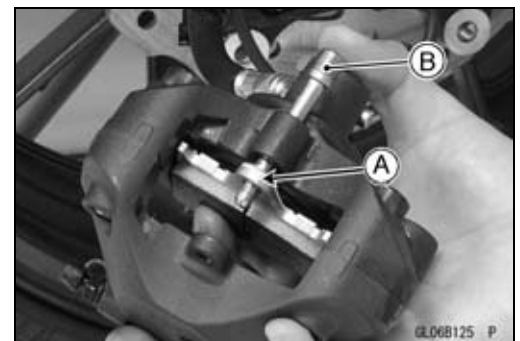

- Set:
 - Inside Pad [A]
 - Pad Spring [B]
- Pushing the pin holder [C] to hole of the pad and insert the pad pin.
- Install the caliper (see Caliper Installation).
- Tighten the pad pin.

Torque - Rear Brake Pad Pin: 17.2 N·m (1.8 kgf·m, 13 ft·lb)

⚠ WARNING

Do not attempt to drive the motorcycle until a full brake pedal is obtained by pumping the brake pedal until the pads are against the disc. The brake will not function on the first application of the pedal if this is not done.

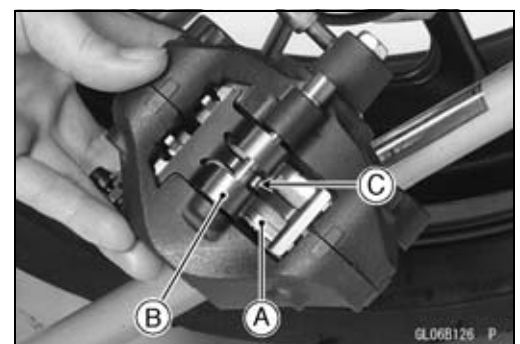

Brake Pad Wear Inspection

- Refer to the Brake Pad Wear Inspection in the Periodic Maintenance chapter.

12-22 BRAKES

Master Cylinder

Front Master Cylinder Removal

- Remove the reservoir bracket bolt [A].
- Remove the banjo bolt [B] to disconnect the brake hose from the master cylinder (see Brake Hose Removal/Installation).
- Unscrew the clamp bolts [C], and take off the master cylinder [D] as an assembly with the reservoir, brake lever, and brake switch installed.
- Disconnect the front brake light switch connector [E].

CAUTION

Immediately wash away any brake fluid that spills.

- Remove:
 - Brake Lever Pivot Bolt [A] and Nut
 - Brake Lever [B]
 - Clamp [C] (Slide Out)
 - Brake Hose [D]
 - Front Brake Light Switch [E]

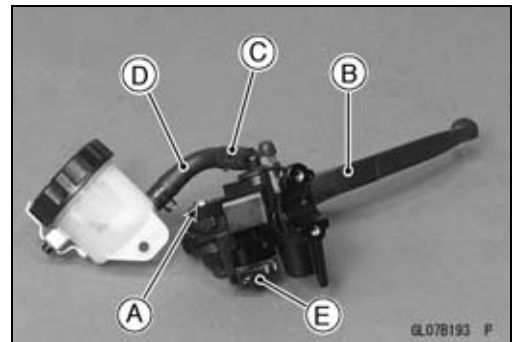
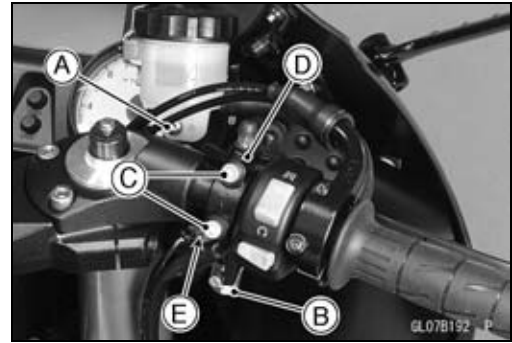

Front Master Cylinder Installation

- Set the front master cylinder to match its mating surface [A] to the punch mark [B] of the handlebar.
- The master cylinder clamp must be installed with the arrow mark [C] upward.
- Tighten the upper clamp bolt first, and then the lower clamp bolt.

Torque - Front Master Cylinder Clamp Bolts: 8.8 N·m (0.90 kgf·m, 78 in·lb)

- Replace the washers that are on each side of the hose fitting with new ones.
- Tighten:
 - Torque - Brake Hose Banjo Bolt: 25 N·m (2.5 kgf·m, 18 ft·lb)**
- Bleed the brake line (see Brake Line Bleeding).
- Check the brake for good braking power, no brake drag, and no fluid leakage.

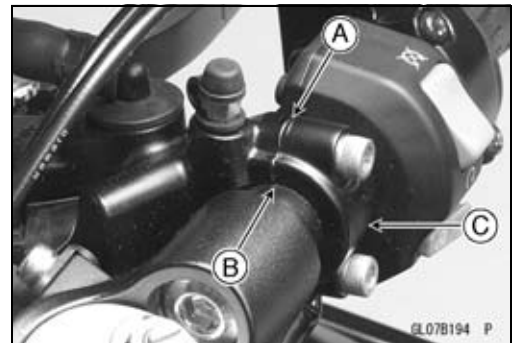

Rear Master Cylinder Removal

- Unscrew the brake hose banjo bolt [A] and brake hose [B].
- Remove:
 - Cotter Pin [C]
 - Joint Pin [D]
 - Bolts [E]
 - Foot Guard [F]
 - Rear Master Cylinder
- Slide out the clamp [G].
- Pull off the reservoir hose lower end, and drain the brake fluid into a container.

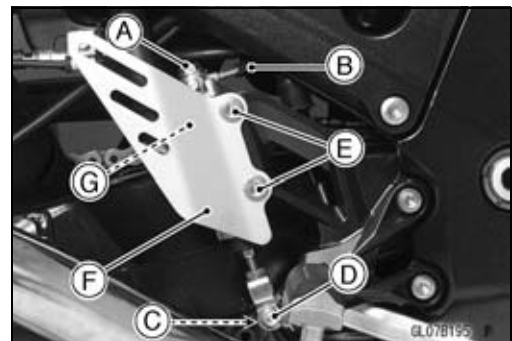

Master Cylinder

Rear Master Cylinder Installation

- Replace the cotter pin with a new one.
- Replace the washers that are on each side of hose fitting with new ones.
- Tighten:

Torque - Rear Master Cylinder Mounting Bolts: 25 N·m (2.5 kgf·m, 18 ft·lb)

Brake Hose Banjo Bolt: 25 N·m (2.5 kgf·m, 18 ft·lb)

- Bleed the brake line (see Brake Line Bleeding).
- Check the brake for good braking power, no brake drag, and no fluid leakage.

Front Master Cylinder Disassembly

- Refer to the Master Cylinder Rubber Parts Replacement in the Periodic Maintenance chapter.

Rear Master Cylinder Disassembly

- Refer to the Master Cylinder Rubber Parts Replacement in the Periodic Maintenance chapter.

Master Cylinder Assembly

- Refer to the Master Cylinder Rubber Parts Replacement in the Periodic Maintenance chapter.

Master Cylinder Inspection (Visual Inspection)

- Remove the master cylinders (see Front/Rear Master Cylinder Removal).
 - Disassemble the front and rear master cylinders (see Master Cylinder Rubber Parts Replacement in the Periodic Maintenance chapter).
 - Check that there are no scratches, rust or pitting on the inner wall [A] of each master cylinder and on the outside of each piston [B].
 - ★ If a master cylinder or piston shows any damage, replace them.
 - Inspect the primary cup [C] and secondary cup [D].
 - ★ If a cup is worn, damaged softened (rotted), or swollen, the piston assembly should be replaced to renew the cups.
 - ★ If fluid leakage is noted at the brake lever, the piston assembly should be replaced to renew the cups.
- Front Master Cylinder [J]

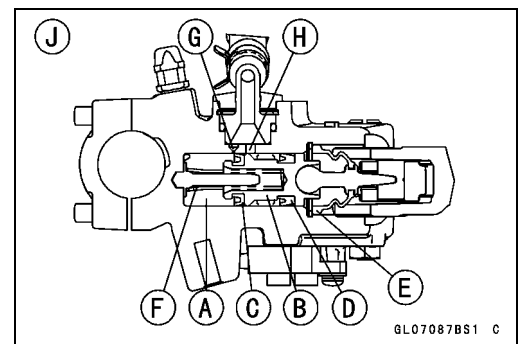

12-24 BRAKES

Master Cylinder

- Check the dust covers [E] for damage.
- ★ If they are damaged, replace them.
- Check the piston return spring [F] for any damage.
- ★ If the springs are damaged, replace them.
- Check that relief port [G] and supply port [H] are not plugged.
- ★ If the relief port becomes plugged, the brake pads will drag on the disc. Blow the ports clean with compressed air.

Rear Master Cylinder [K]

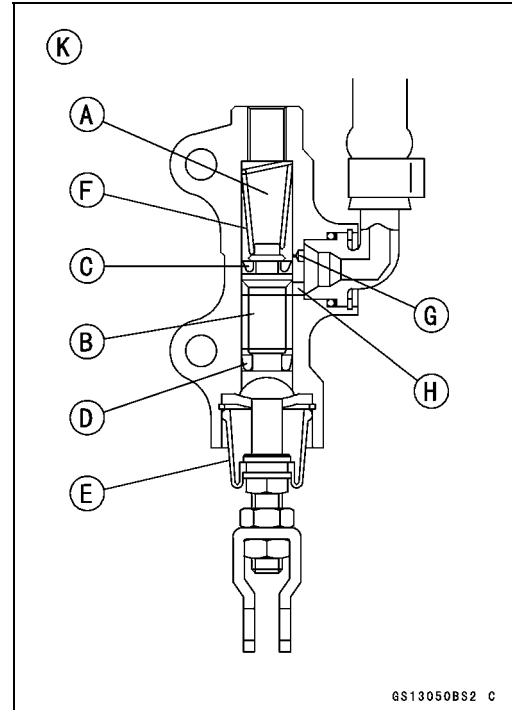

Brake Disc

Brake Disc Removal

- Remove the wheels (see Front/Rear Wheel Removal in the Wheels/Tires chapter).
- Unscrew the mounting bolts, and take off the disc.
- Remove the sensor rotor (ZX1400B Models).

Brake Disc Installation

- Install the brake disc on the wheel so that the marked side [A] faces out.
- Install the sensor rotor on the brake disc so that the marked side faces out (ZX1400B Models).
- Apply a non-permanent locking agent to the threads of the rear brake disc mounting bolts [B].
- Tighten:

Torque - Brake Disc Mounting Bolts: 27 N·m (2.8 kgf·m, 20 ft·lb)



Brake Disc Wear

- Measure the thickness of each disc [A] at the point where it has worn the most.
 - ★ If the disc has worn past the service limit, replace it.
- Measuring Area [B]

Brake Discs Thickness

Standard:

Front	4.8 ~ 5.2 mm (0.19 ~ 0.20 in.)
Rear	5.8 ~ 6.2 mm (0.23 ~ 0.24 in.)

Service Limit:

Front	4.5 mm (0.18 in.)
Rear	5.5 mm (0.22 in.)

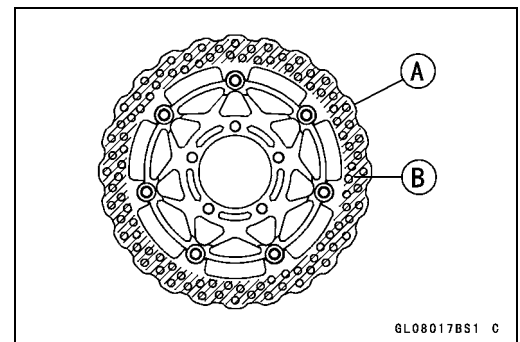

Brake Disc Warp

- Raise the front/rear wheel off the ground.

Special Tools - Jack: 57001-1238

Jack Attachment: 57001-1608

- For front disc inspection, turn the handlebar fully to one side.
- Set up a dial gauge against the disc [A] as shown and measure disc runout, while turning [B] the wheel by hand.
- ★ If runout exceeds the service limit, replace the disc.

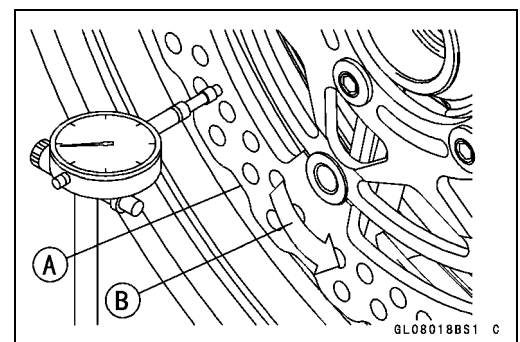

Disc Runout

Standard:	TIR 0.15 mm (0.006 in.) or less
Service Limit:	TIR 0.3 mm (0.01 in.)

12-26 BRAKES

Brake Fluid

Brake Fluid Level Inspection

- Refer to the Brake Fluid Level Inspection in the Periodic Maintenance chapter.

Brake Fluid Change

- Refer to the Brake Fluid Change in the Periodic Maintenance chapter.

Brake Line Bleeding

The brake fluid has a very low compression coefficient so that almost all the movement of the brake lever or pedal is transmitted directly to the caliper for braking action. Air, however, is easily compressed. When air enters the brake lines, brake lever or pedal movement will be partially used in compressing the air. This will make the lever or pedal feel spongy, and there will be a loss in braking power.

⚠ WARNING

Be sure to bleed the air from the brake line whenever brake lever or pedal action feels soft or spongy after the brake fluid is changed, or whenever a brake line fitting has been loosened for any reason.

NOTE

○ *The procedure to bleed the front brake line is as follows. Bleeding the rear brake line is the same as for the front brake.*

- Remove:
 - Screw [A]
 - Clamp [B]
 - Front Brake Reservoir Cap [C]
 - Diaphragm Plate
 - Diaphragm
- Fill the reservoir with fresh brake fluid to the upper level line in the reservoir.
- Slowly pump the brake lever several times until no air bubbles can be seen rising up through the fluid from the holes at the bottom of the reservoir.
- Bleed the air completely from the master cylinder by this operation.
- Remove the rubber cap from the bleed valve on the front master cylinder.
- Attach a clear plastic hose [A] to the bleed valve, and run the other end of the hose into a container.

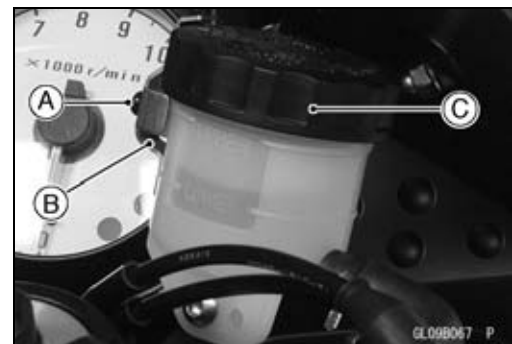

Brake Fluid

- Bleed the brake line and the master cylinder.
- Repeat this operation until no more air can be seen coming out into the plastic hose.
 1. Pump the brake lever until it becomes hard, and apply the brake and hold it [A].
 2. Quickly open and close [B] the bleed valve while holding the brake applied.
 3. Release the brake [C].

NOTE

- *The fluid level must be checked often during the bleeding operation and replenished with fresh brake fluid as necessary. If the fluid in the reservoir runs completely out any time during bleeding, the bleeding operation must be done over again from the beginning since air will have entered the line.*

- Remove the clear plastic hose.
- Tighten the bleed valve, and install the rubber cap.

Torque - Front Master Cylinder Bleed Valve: 7.8 N·m (0.80 kgf·m, 69 in·lb)

- Remove the rubber cap [A] from the bleed valve on the caliper.
- Attach a clear plastic hose [B] to the bleed valve, and run the other end of the hose into a container.

- Bleed the brake line and the caliper.
- Repeat this operation until no more air can be seen coming out into the plastic hose.
 1. Pump the brake lever until it becomes hard, and apply the brake and hold it [A].
 2. Quickly open and close [B] the bleed valve while holding the brake applied.
 3. Release the brake [C].

NOTE

- *The fluid level must be checked often during the bleeding operation and replenished with fresh brake fluid as necessary. If the fluid in the reservoir runs completely out any time during bleeding, the bleeding operation must be done over again from the beginning since air will have entered the line.*

○ *Tap the brake hose lightly from the caliper to the reservoir for more complete bleeding.*

○ *Front Brake: First bleeding the right caliper then repeat the above steps for the left caliper.*

- Remove the clear plastic hose.

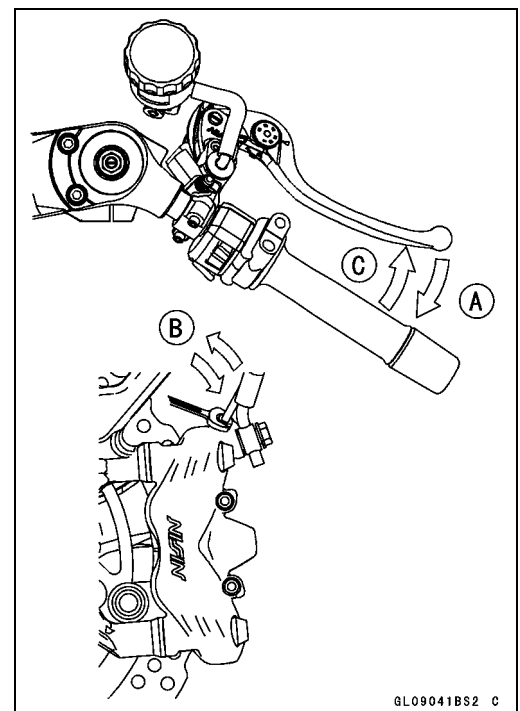
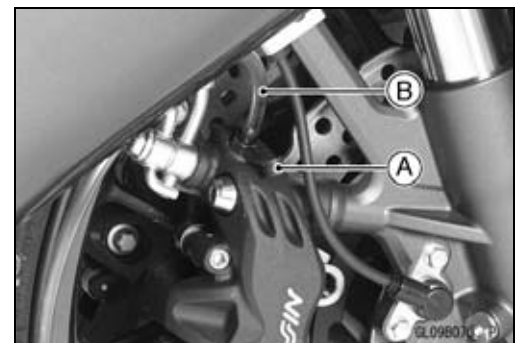
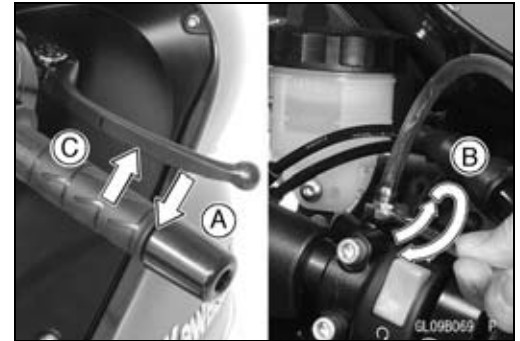

GL09041BS2 C

12-28 BRAKES

Brake Fluid

- Install:
 - Diaphragm
 - Diaphragm Plate
 - Front Brake Reservoir Cap [A]
 - Clamp [B]
 - Screw [C]

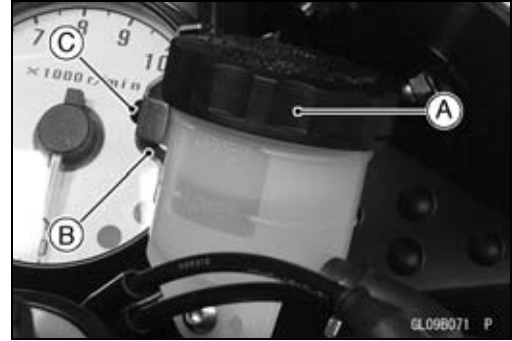

- Follow the procedure below to install the front/rear brake fluid reservoir cap correctly.
 - First, tighten the brake fluid reservoir cap [B] clockwise [C] by hand until slight resistance is felt indicating that the cap is seated on the reservoir body, then tighten the cap an additional 1/6 turn [D] while holding the brake fluid reservoir body [A].

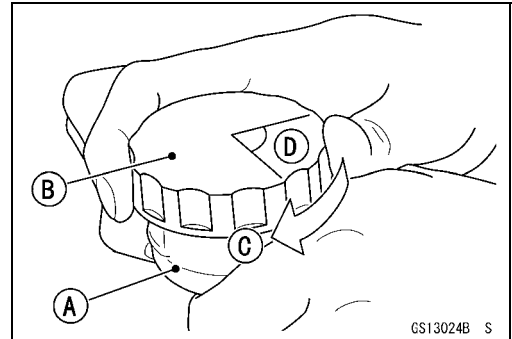

- Tighten:
 - Torque - Front Brake Reservoir Cap Stopper Screw: 1.2 N·m (0.12 kgf·m, 11 in·lb)**
- Tighten the bleed valve, and install the rubber cap.
 - Torque - Bleed Valve: 7.8 N·m (0.80 kgf·m, 69 in·lb)**
- Check the fluid level (see Brake Fluid Level Inspection in the Periodic Maintenance chapter).
- After bleeding is done, check the brake for good braking power, no brake drag, and no fluid leakage.

Brake Fluid

⚠ WARNING

When working with the disc brake, observe the precautions listed below.

1. Never reuse old brake fluid.
2. Do not use fluid from a container that has been left unsealed or that has been open for a long time.
3. Do not mix two types and brands of fluid for use in the brake. This lowers the brake fluid boiling point and could cause the brake to be ineffective. It may also cause the rubber brake parts to deteriorate.
4. Don't leave the reservoir cap off for any length of time to avoid moisture contamination of the fluid.
5. Don't change the fluid in the rain or when a strong wind is blowing.
6. Except for the disc pads and disc, use only disc brake fluid, isopropyl alcohol, or ethyl alcohol for cleaning of the brake parts. Do not use any other fluid for cleaning these parts. Gasoline, engine oil, or any other petroleum distillate will cause deterioration of the rubber parts. Oil spilled on any part will be difficult to wash off completely and will eventually deteriorate the rubber used in the disc brake.
7. When handling the disc pads or disc, be careful that no disc brake fluid or any oil gets on them. Clean off any fluid or oil that inadvertently gets on the pads or disc with a high-flash point solvent. Do not use one which will leave an oily residue. Replace the pads with new ones if they cannot be cleaned satisfactorily.
8. Brake fluid quickly ruins painted surfaces; any spilled fluid should be completely wiped up immediately.
9. If any of the brake line fittings or the bleed valve is opened at any time, the **AIR MUST BE BLED FROM THE BRAKE LINE.**

12-30 BRAKES

Brake Hose

Brake Hose and Pipe Removal/Installation

- Refer to the Brake Hose and Pipe Replacement in the Periodic Maintenance chapter.

Brake Hose and Pipe Inspection

- Refer to the Brake Hose and Pipe Damage and Installation Condition Inspection in the Periodic Maintenance chapter.

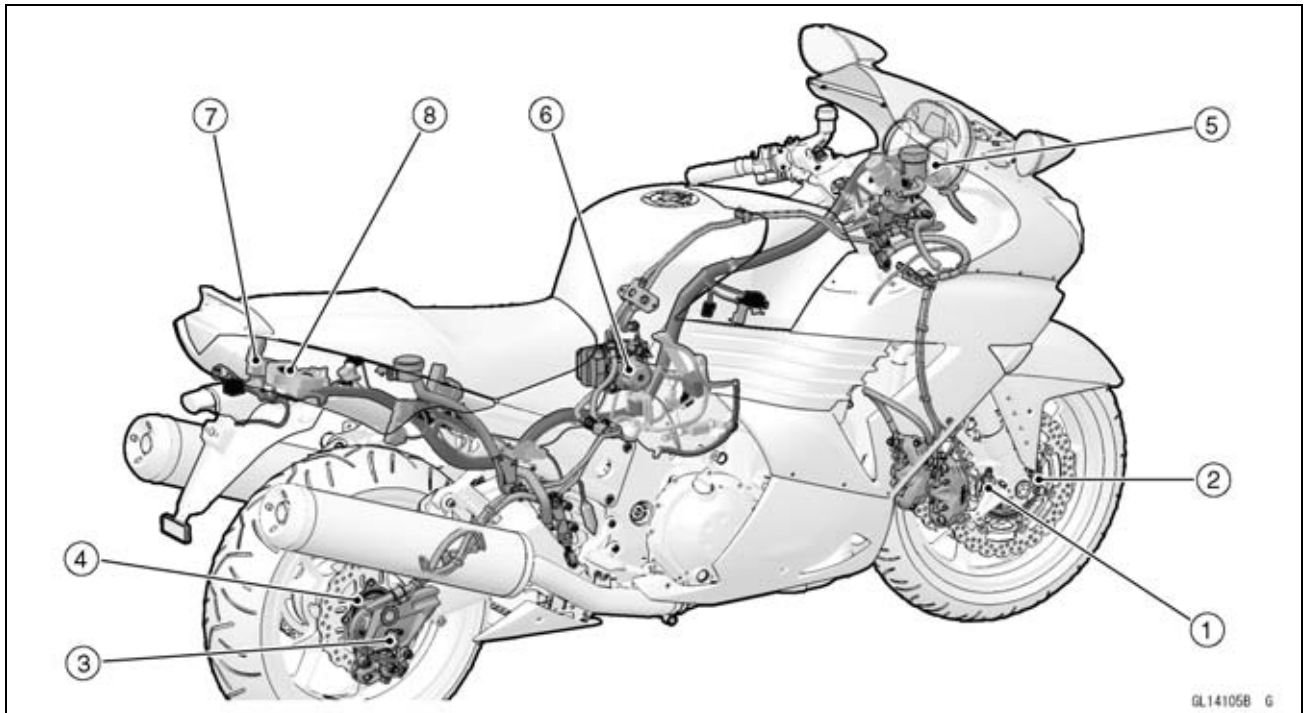
Anti-Lock Brake System (Equipped Models)**Parts Location**

1. Front Wheel Rotation Sensor
2. Front Wheel Rotation Sensor Rotor
3. Rear Wheel Rotation Sensor
4. Rear Wheel Rotation Sensor Rotor
5. ABS Indicator Light (LED)
6. ABS Hydraulic Unit
7. ABS Fuse Box
8. ABS Kawasaki Self-diagnosis System Connector

12-32 BRAKES

Anti-Lock Brake System (Equipped Models)

ABS System Wiring Diagram

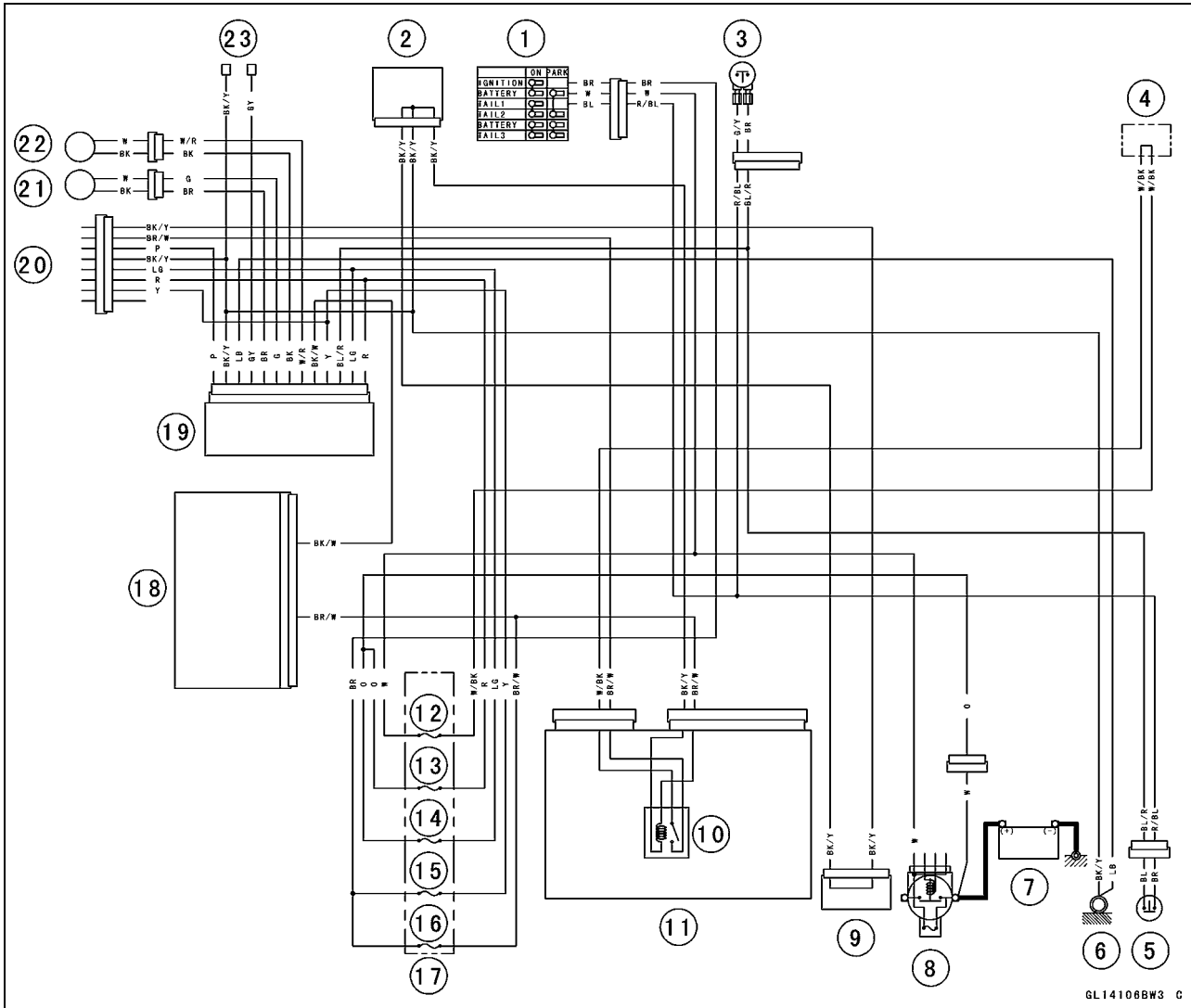

1. Ignition Switch
2. Joint Connector 1
3. Front Brake Switch
4. Water-proof Joint 1
5. Rear Brake Switch
6. Frame Ground
7. Battery 12 V 14 Ah
8. Main Fuse 30 A
9. Joint Connector 2
10. Main Relay
11. Relay Box
12. ECU Fuse 15 A
13. ABS Motor Relay Fuse 30 A
14. ABS Solenoid Valve Relay Fuse 20 A
15. ABS ECU Fuse 10 A
16. Ignition Fuse 10 A
17. Fuse Box 2
18. Meter Unit
19. ABS Hydraulic Unit
20. ABS Kawasaki Self-diagnosis System Connector
21. Front Wheel Rotation Sensor
22. Rear Wheel Rotation Sensor
23. ABS Self-diagnosis Terminal

Anti-Lock Brake System (Equipped Models)

Terminal Names

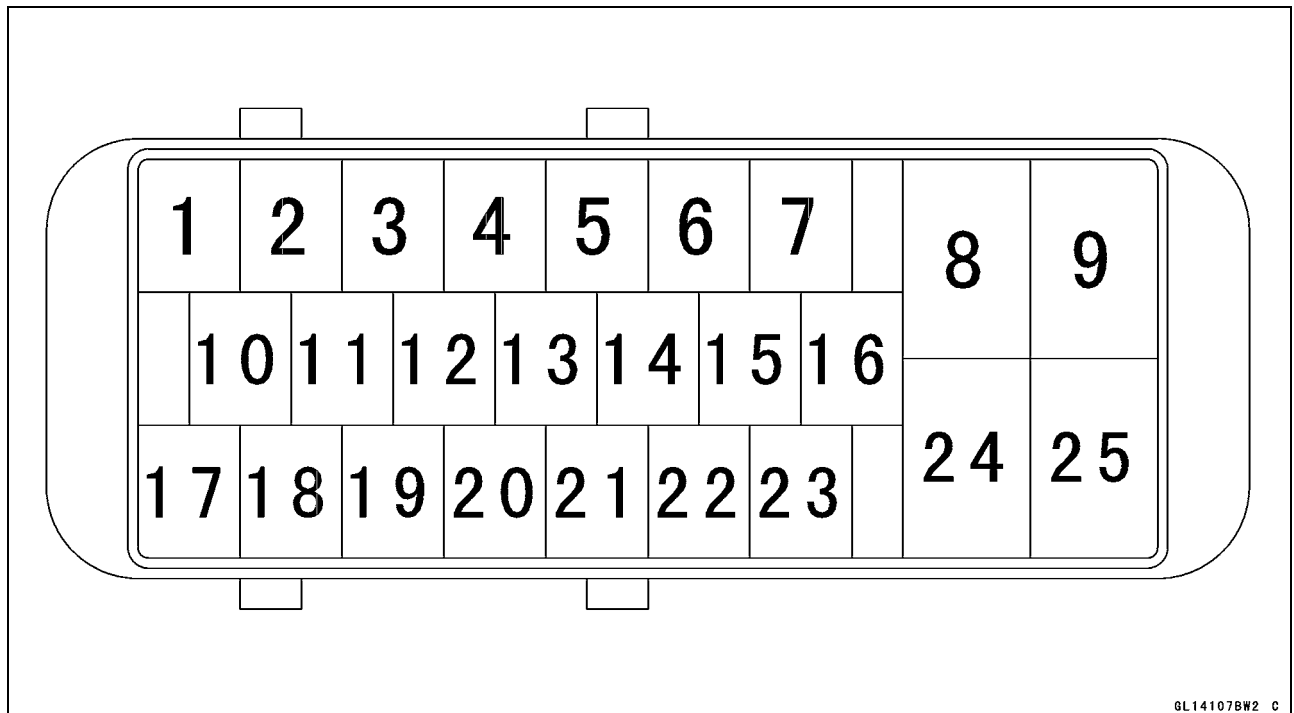

GL14107BW2 C

1. Unused
2. Power Supply to Rear Wheel Rotation Sensor
3. Front Wheel Rotation Sensor Signal
4. Front and Rear Brake Light Switch
5. Unused
6. Unused
7. Unused
8. Power Supply to ABS Solenoid Valve Relay
9. Power Supply to ABS Motor Relay
10. ABS Kawasaki Self-diagnosis System Terminal
11. Unused
12. Power Supply to Front Wheel Rotation Sensor
13. ABS Self-diagnosis Terminal
14. Unused
15. Unused
16. Power Supply
17. Unused
18. Rear Wheel Rotation Sensor Signal
19. Unused
20. Unused
21. ABS Indicator Light (LED)
22. Unused
23. Unused
24. Ground
25. Ground to Motor

12-34 BRAKES

Anti-Lock Brake System (Equipped Models)

ABS Servicing Precautions

There are a number of important precautions that should be followed servicing the ABS system.

- This ABS system is designed to be used with a 12 V sealed battery as its power source. Do not use any other battery except for a 12 V sealed battery as a power source.
- Do not reverse the battery cable connections. This will damage the ABS hydraulic unit.
- To prevent damage to the ABS parts, do not disconnect the battery cables or any other electrical connections when the ignition switch is ON or while the engine is running.
- Take care not to short the leads that are directly connected to the battery positive (+) terminal to the chassis ground.
- Do not turn the ignition switch ON while any of the ABS electrical connectors are disconnected. The ABS hydraulic unit memorizes service codes.
- Do not spray water on the electrical parts, ABS parts, connectors, leads and wiring.
- If a transceiver is installed on the motorcycle, make sure that the operation of the ABS system is not influenced by electric wave radiated from the antenna. Locate the antenna as far as possible away from the ABS hydraulic unit.
- Whenever the ABS electrical connections are to be disconnected, first turn off the ignition switch.
- The ABS parts should never be struck sharply, as with a hammer, or allowed to fall on a hard surface. Such a shock to the parts can damage them.
- The ABS parts cannot be disassembled. Even if a fault is found, do not try to disassemble and repair the ABS parts, replace it.
- The ABS has many brake lines, pipes, and leads. And the ABS cannot detect problems with the conventional braking system (brake disc wear, unevenly worn brake pad, and other mechanical faults). To prevent trouble, check the brake lines and pipes for correct routing and connection, the wiring for correct routing, and the brakes for proper braking power. Be sure to check for fluid leakage, and bleed the brake line thoroughly.

⚠ WARNING

If any of the brake line fittings, including the ABS hydraulic unit joint nuts, or the bleed valve is opened at any time, the air must be bled completely from the brake line.

CAUTION

Do not ride the motorcycle with air in the brake line, or the ABS could malfunction.

Anti-Lock Brake System (Equipped Models)

- The ABS indicator light (LED) [A] may light if the tire pressure is incorrect, a non-recommended tire is installed, or the wheel is deformed. If the indicator light lights, remedy the problem and clear the service code.

▲ WARNING

Use of non-recommended tires may cause malfunctioning of ABS and can lead to extended braking distance. The rider could have an accident as a result. Always use recommended standard tires for this motorcycle.

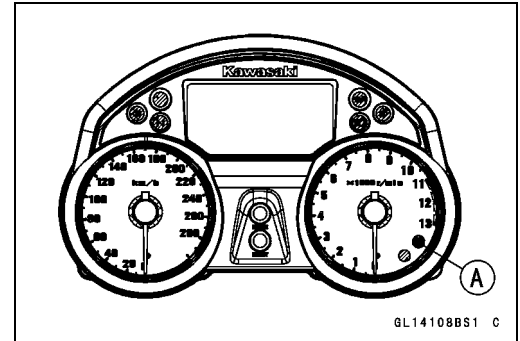

- The ABS indicator light (LED) may come on if the engine is run with the motorcycle on its stand and the transmission in gear. If the indicator light comes on, just turn the ignition switch OFF, then clear service code 42, which indicates a "Faulty front wheel rotation sensor".
- When the ABS operates, the ABS makes noise and the rider feels the reaction force on the brake lever and brake pedal. This is a normal condition. It informs the rider that the ABS is operating normally.
- Service codes detected once by the ABS hydraulic unit will be memorized in the ABS hydraulic unit. Therefore, after maintenance work is finished, be sure to erase the service codes. Do not erase the service codes during troubleshooting. Wait until all the checks and repair work are finished to prevent duplication of previous service codes and unnecessary maintenance work.
- Before delivering the motorcycle to the customer, be sure to erase any service codes which might be stored in the ABS hydraulic unit. Using the self-diagnosis feature, make sure that the ABS indicator light (LED) lights. A fully charged battery is a must for conducting reliable self-diagnosis. Test run the motorcycle at a speed of more than 20 km/h (12 mph) to see that the ABS indicator light (LED) does not come on. Finally, test run the motorcycle at a speed of more than 30 km/h (20 mph) and brake suddenly to see that the motorcycle stops without loss of steering control and the ABS operates normally (The reaction force generated is felt in the brake lever and pedal.). This completes the final inspection.
- Color Codes:

BK: Black	G: Green	P: Pink
BL: Blue	GY: Gray	PU: Purple
BR: Brown	LB: Light Blue	R: Red
CH: Chocolate	LG: Light Green	W: White
DG: Dark Green	O: Orange	Y: Yellow

12-36 BRAKES

Anti-Lock Brake System (Equipped Models)

ABS Troubleshooting Outline

When an abnormality in the system occurs, the ABS indicator light (LED) lights up to alert the rider. In addition, the nature of the fault is stored in the memory of the ABS hydraulic unit and when in the self-diagnosis mode, the service code [A] is indicated by the number of times the ABS indicator light (LED) blinks. The service codes stored in memory are not erased until the mode has been changed to the fault erase mode after the fault has been corrected. Therefore, after correcting the problem, always erase the service codes and then run the self-diagnosis program to confirm normal signal output. When, due to a malfunction, the ABS indicator light (LED) remains lit, get a thorough understanding of the background before starting the repair work. Ask the rider about the conditions [B] under which the problem occurred and try to determine the cause [C]. Do not rely solely on the ABS self-diagnosis function, use common sense; check the brakes for proper braking power, and brake fluid level, search for leaks, etc.

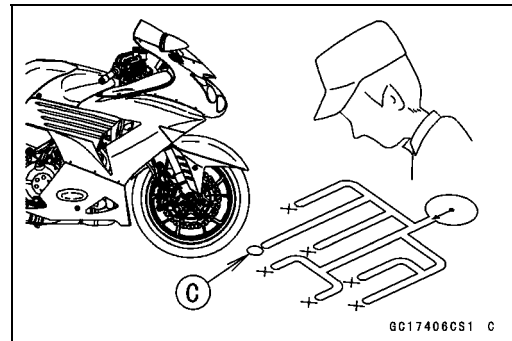
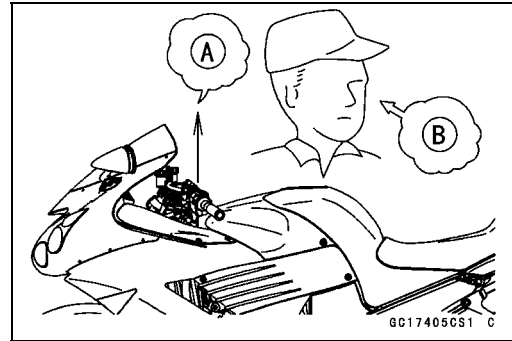

Even when the ABS is operating normally, the ABS indicator light (LED) may light up under the conditions listed below. Turn the ignition switch OFF to stop the indicator light. If the motorcycle runs without erasing the service code, the light may light up again.

- After continuous riding on a rough road.
- When the engine is started with the stand raised and the transmission engaged, and the rear wheel turns.
- When accelerating so abruptly that the front wheel leaves the ground.
- When the ABS has been subjected to strong electrical interference.
- When tire pressure is abnormal. Adjust tire pressure.
- When a tire different in size from the standard size is being used. Replace with standard size.
- When the wheel is deformed. Replace the wheel.

Much of the ABS troubleshooting work consists of confirming continuity of the wiring. The ABS parts are assembled and adjusted by the manufacturer, so there is no need to disassemble or repair them. Replace the ABS hydraulic unit.

The basic troubleshooting procedures are listed below.

- Carry out pre-diagnosis inspections as a preliminary inspection.
- Determine the fault using the self-diagnosis function.
- Check wiring and connections from the ABS hydraulic unit connector to the suspected faulty ABS part, using the hand tester.

Special Tool - Hand Tester: 57001-1394

Anti-Lock Brake System (Equipped Models)

- Visually inspect the wiring for signs of burning or fraying.
- ★ If any wiring is poor, replace the damaged wiring.
- Pull each connector [A] apart and inspect it for corrosion, dirt and damage.
- ★ If the connector is corroded or dirty, clean it carefully. If it is damaged, replace it.
- Check the wiring for continuity.
- Use the wiring diagram to find the ends of the lead which is suspected of being a problem.
- Connect the hand tester between the ends of the leads.

Special Tool - Hand Tester: 57001-1394

- Set the tester to the $\times 1 \Omega$ range, and read the tester.
- ★ If the tester does not read 0Ω , the lead is defective. Replace the main harness [B] if necessary.
- Narrow down suspicious parts and close in on the faulty ABS part by repeating the continuity tests.
- ★ If no abnormality is found in the wiring or connectors, the ABS parts are the next likely suspects. Check each part one by one.
- ★ If an abnormality is found, replace the affected ABS part.

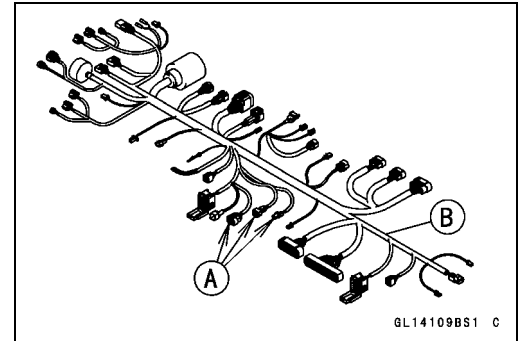

12-38 BRAKES

Anti-Lock Brake System (Equipped Models)

ABS Diagnosis Flow Chart

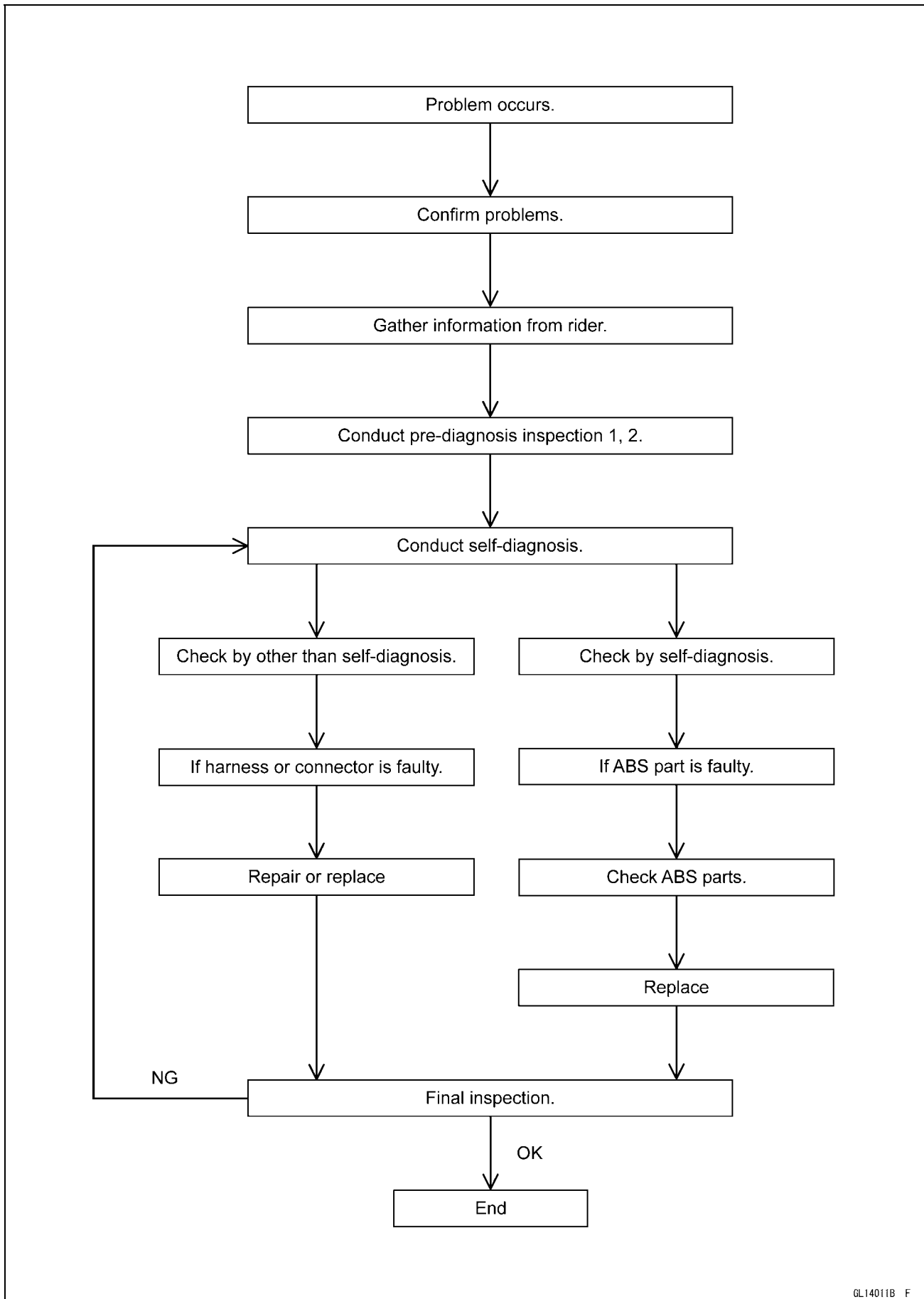

Anti-Lock Brake System (Equipped Models)

Inquiries to Rider

- Each rider reacts to problems in different ways, so it is important to confirm what kind of condition the rider is dissatisfied with.
- Try to find out exactly what problem occurs under exactly what conditions by asking the rider; knowing this information may help you reproduce the problem in the shop.
- The diagnosis sheet will help prevent you from overlooking any keys, so always use it.

Sample Diagnosis Sheet

Rider name:				Registration No. (license plate No.):			
Year of initial registration:				Model:			
Engine No.:				Frame No.:			
Date problem occurred:				Frequency:			
Weather:				Mileage:			
Phenomenon	<input type="checkbox"/> Brake lever vibration or noise	<input type="checkbox"/> Indicator light blinks	<input type="checkbox"/> Braking distance too long	<input type="checkbox"/> Abnormal brake lever movement	<input type="checkbox"/> ABS not working	<input type="checkbox"/> ABS works but indicator light doesn't light up	<input type="checkbox"/> ABS operating too frequently
	<input type="checkbox"/> Pedal vibration or noise	<input type="checkbox"/> Indicator light remains lit up		<input type="checkbox"/> Abnormal pedal movement			
Engine conditions at problem	<input type="checkbox"/> At start-up		<input type="checkbox"/> After starting		<input type="checkbox"/> At 5 000 r/min (rpm) or more		
Road conditions	<input type="checkbox"/> Slippery road (<input type="checkbox"/> snow, <input type="checkbox"/> gravel, <input type="checkbox"/> other)						
	<input type="checkbox"/> Rough surface						
	<input type="checkbox"/> Other						
Driving conditions	<input type="checkbox"/> High-speed cornering						
	<input type="checkbox"/> Driving 10 km/h (6 mph) or above						
	<input type="checkbox"/> Driving below 10 km/h (6 mph)						
	<input type="checkbox"/> When stopping						
	<input type="checkbox"/> When turning						
Brake application	<input type="checkbox"/> Gradual						
	<input type="checkbox"/> Abrupt						
Other conditions	<input type="checkbox"/> Large brake lever stroke						
	<input type="checkbox"/> Large pedal stroke						

12-40 BRAKES

Anti-Lock Brake System (Equipped Models)

Pre-Diagnosis Inspection 1

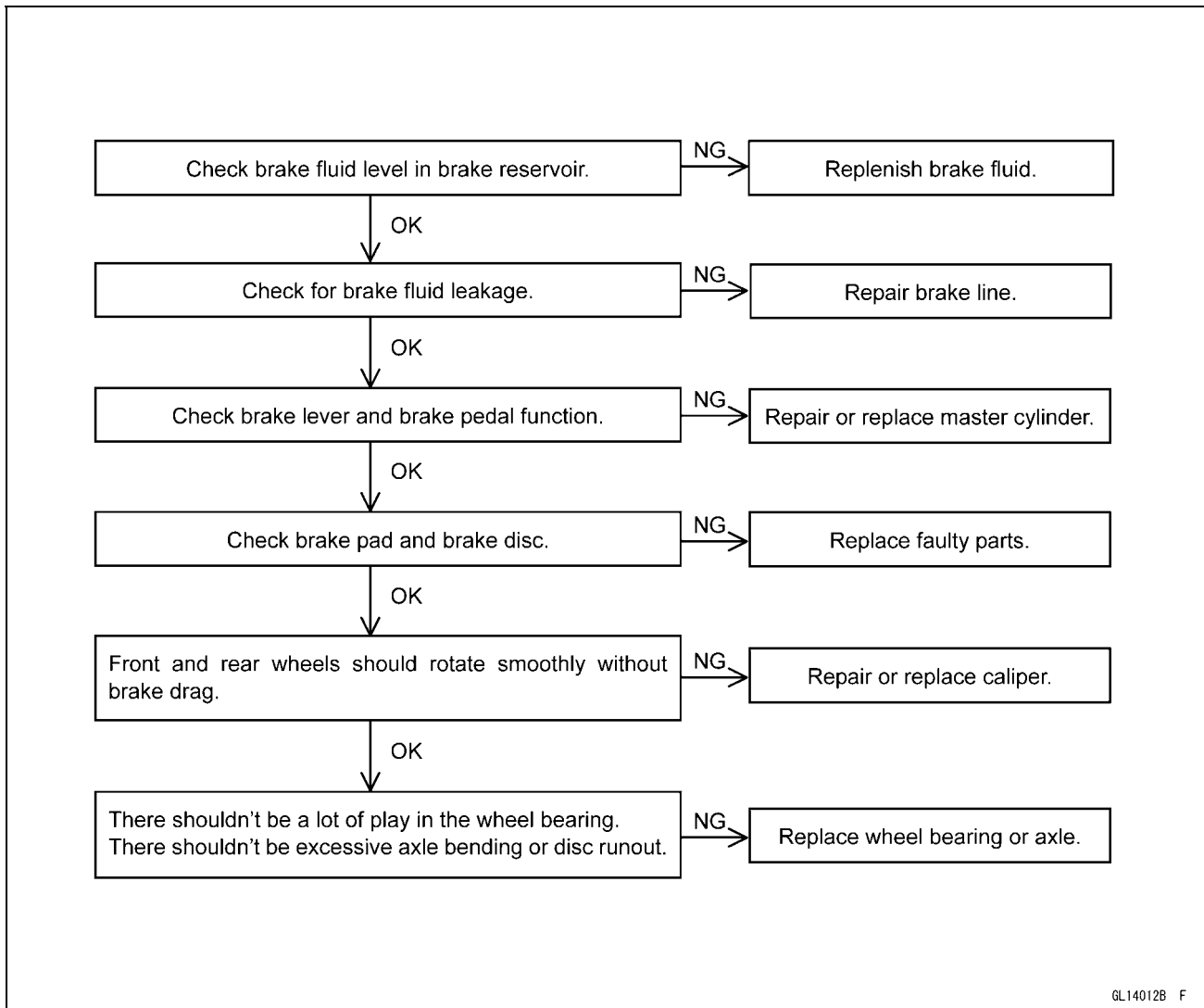

Anti-Lock Brake System (Equipped Models)

Pre-Diagnosis Inspection 2

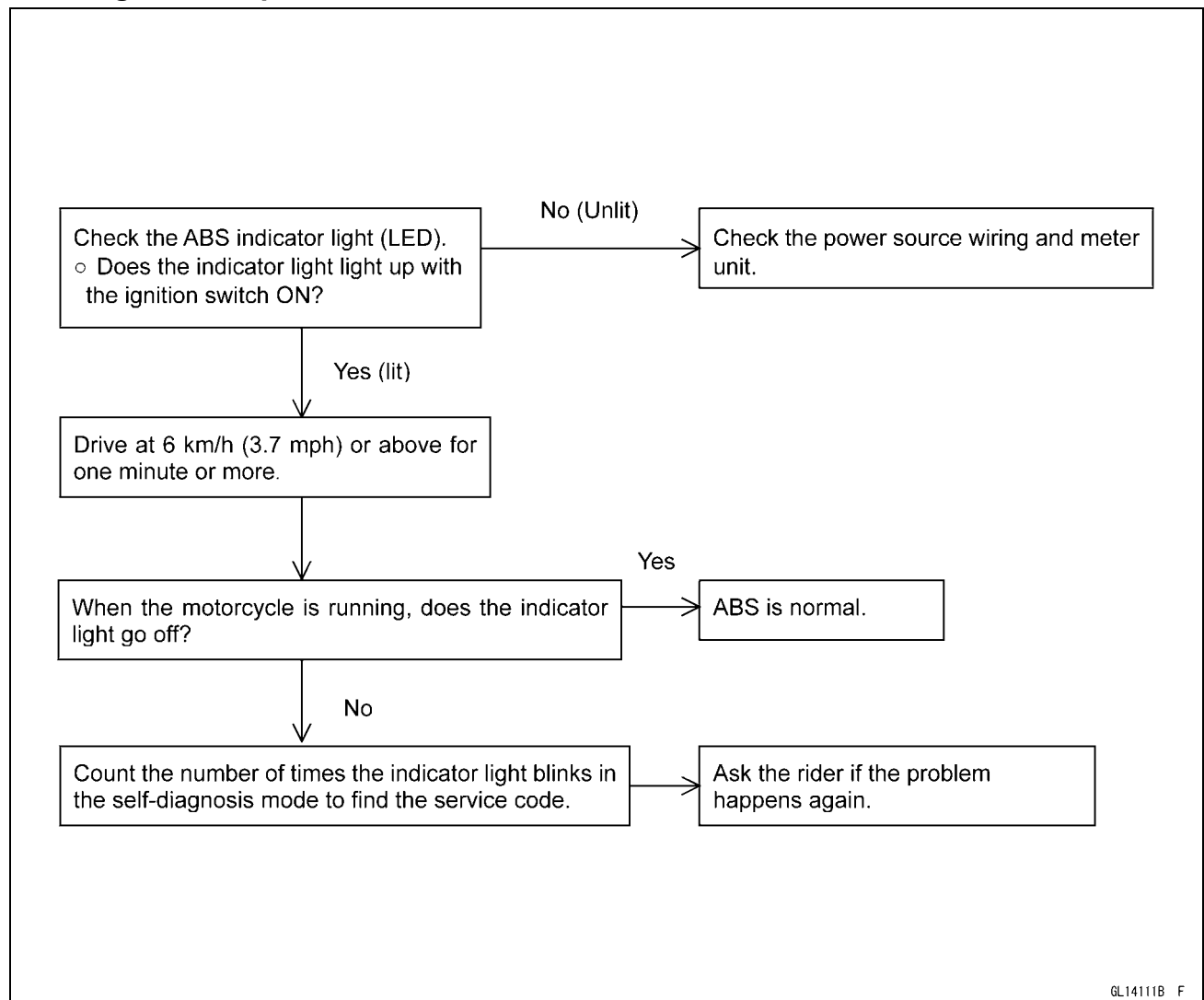

Self-diagnosis Outline

When the indicator light has blinked or come on, the ABS hydraulic unit memorizes and stores the service code for the service person to troubleshoot easily. The service code memory is powered directly by the battery and cannot be canceled by the ignition switch.

The ABS hydraulic unit can memorize up to all service codes (14 codes). Further service codes are memorized after erasing the preceding all service codes (14 codes). If there is no fault, the ABS indicator light (LED) lights, indicating that "The ABS is normal".

Self-diagnosis Procedures

○When a problem occurs with the ABS system, the ABS indicator light (LED) [A] lights.

NOTE

- Use a fully charged battery when conducting self-diagnosis. Otherwise, the light blinks very slowly or doesn't blink.
- The motorcycle is stopped.
- Keep the self-diagnosis terminal grounded during self-diagnosis, with an auxiliary lead.

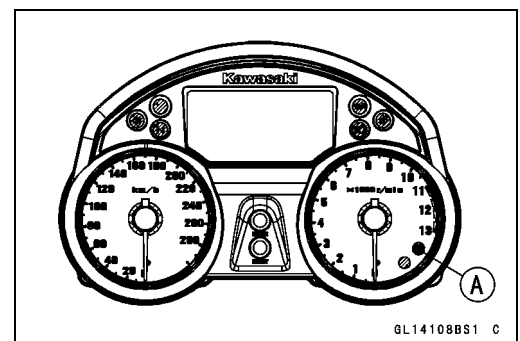

12-42 BRAKES

Anti-Lock Brake System (Equipped Models)

- Remove the seat (see Seat Removal in the Frame chapter).
- Ground the self-diagnosis terminal [A] (Gray) to the ground terminal [B] (Black/Yellow), using a lead.
- Turn on the ignition switch.
- Count the blinks of the light to read the service code.
Keep the auxiliary lead ground until you finish reading the service code.

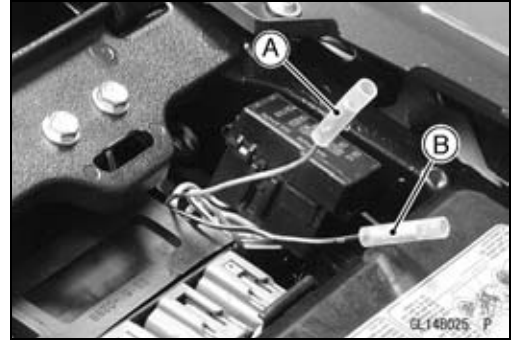

Service Code Clearing Procedures

- Start the service code erase mode with the following procedure.
- The erase mode starts when the ABS self-diagnosis terminal is disconnected from the ground terminal after starting the self-diagnosis mode.
- The service code can be erased by grounding and ungrounding (each time for at least one second) the ABS self-diagnosis terminal three times or more within about 12.5 seconds after starting the erase mode.
- The ABS indicator light (LED) remains lit during the erase mode.
- After erasing, the ABS indicator light (LED) blinks and lights.
- Once erasing is finished, enter the self-diagnosis mode again to confirm that the service codes have been erased. If the ABS has been reset and all codes have been erased, the ABS indicator light (LED) lights.

Anti-Lock Brake System (Equipped Models)

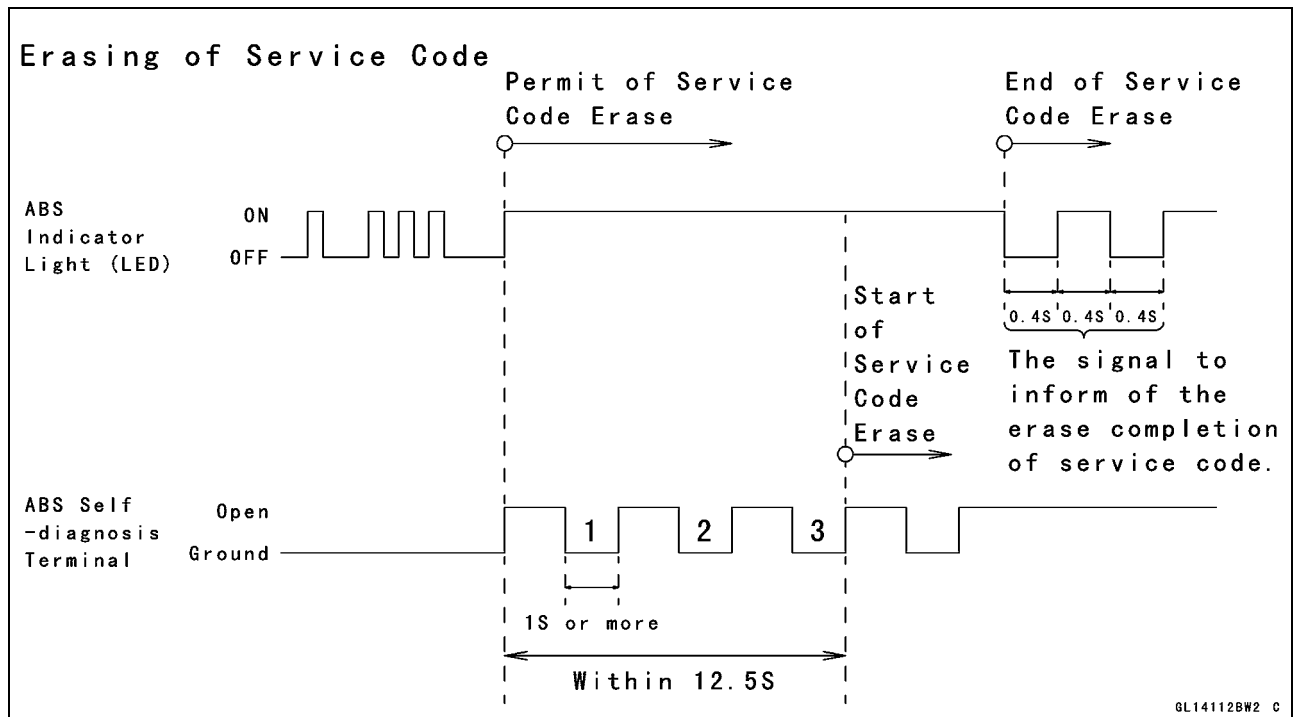

12-44 BRAKES

Anti-Lock Brake System (Equipped Models)

Self-diagnosis Flow Chart

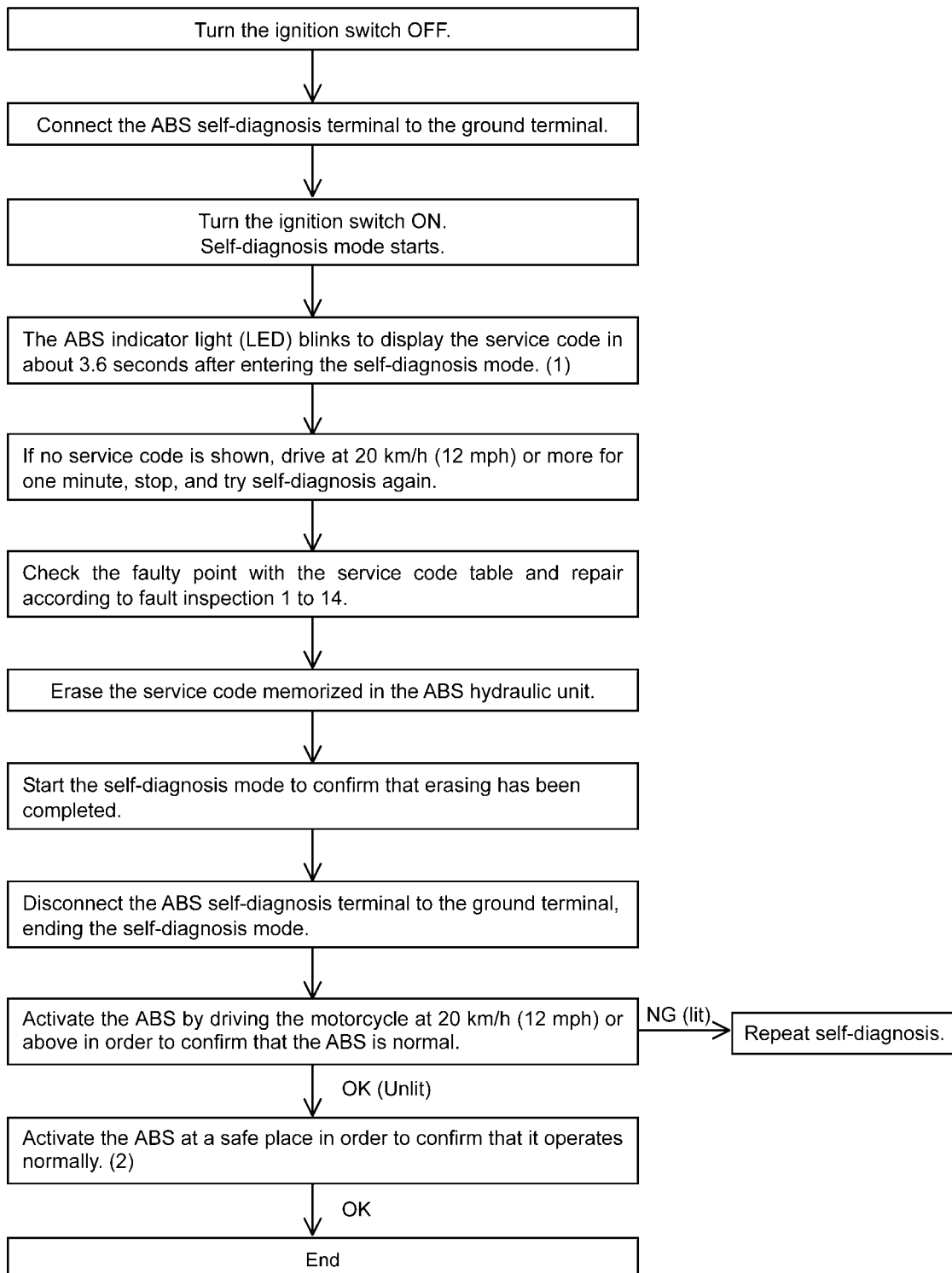

(1): The self-diagnosis mode ends following.

When the ignition switch is OFF.

When the motorcycle is driven while in the self-diagnosis mode.

When the self-diagnosis terminal disconnects.

(2): Apply brake suddenly at 30 km/h (19 mph) or more to confirm that the motorcycle stops smoothly and steady with pulsation on the brake lever and pedal.

Anti-Lock Brake System (Equipped Models)

How to Read Service Codes

- Service codes are shown by a series of long and short blinks of the ABS indicator light (LED) as shown below.
- Read 10th digit and unit digit as the ABS indicator light (LED) blinks.
- When there are a number of faults, a maximum of all service codes (14 codes) can be stored and the display will begin starting from the small number code entered.
- For the display pattern, first the smallest number code is shown, next up to all service codes (14 codes) starting with the last one stored, then the display is repeated from the smallest number code once again.

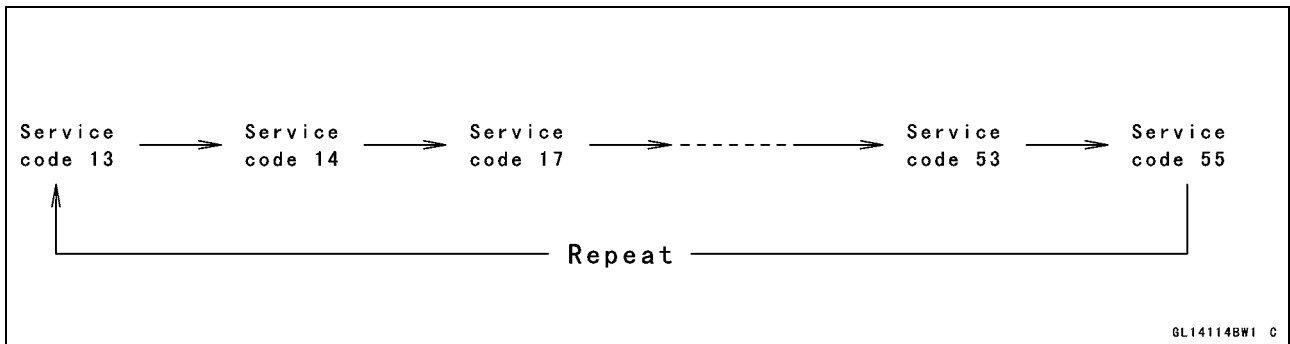

○If there is no fault, the ABS indicator light (LED) lights as shown in the figure.

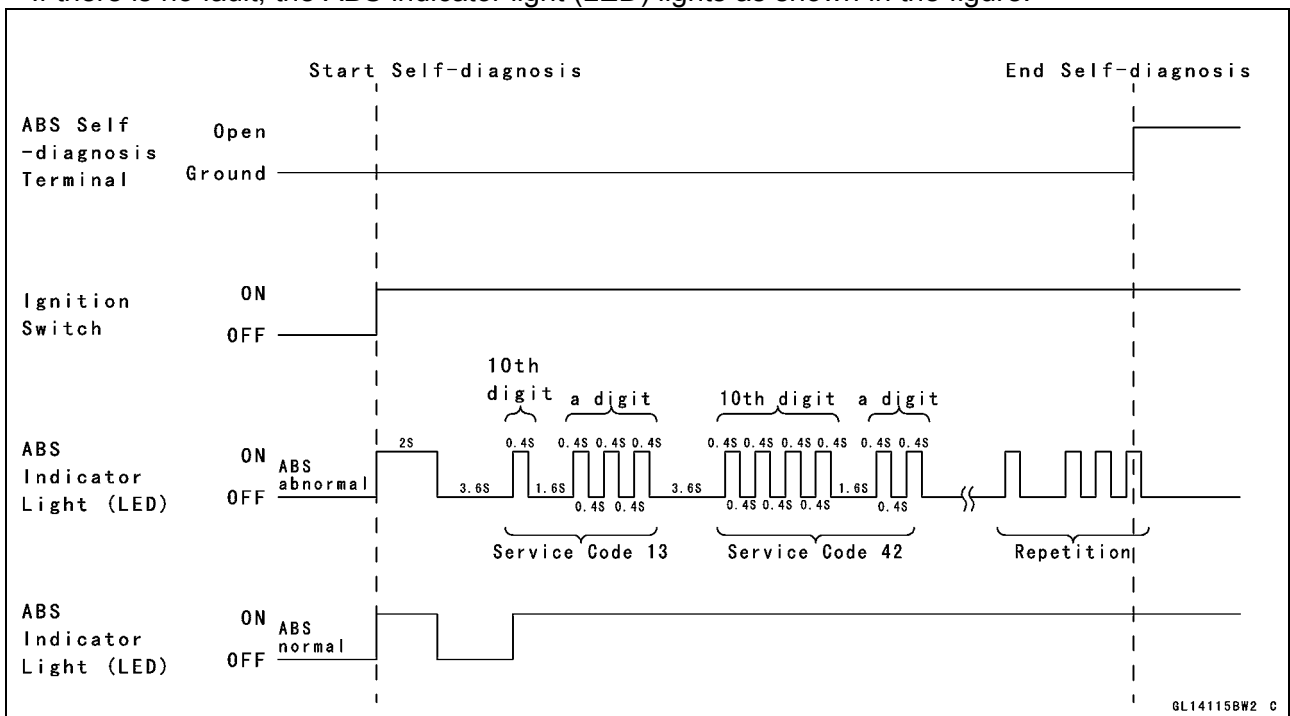







How to Erase Service Codes

- Even if the ignition switch is turned OFF, the battery or the ABS hydraulic unit are disconnected, all service codes remain in the ABS hydraulic unit.
- Refer to the Service Code Clearing Procedure for the service code erasure.

12-46 BRAKES

Anti-Lock Brake System (Equipped Models)

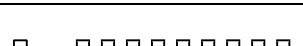
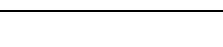
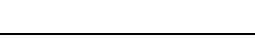
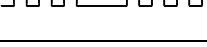
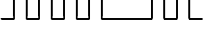
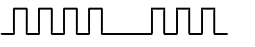
Service Code Table

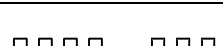
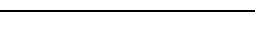
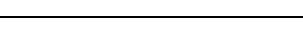
Service Code	ABS Indicator Light (LED)	Problems	Light State
13	 ON OFF	Rear inlet solenoid valve trouble (shorted or open, stuck valve (ON))	ON
14		Rear outlet solenoid valve trouble (shorted or open, stuck valve (ON))	ON
17		Front inlet solenoid valve trouble (shorted or open, stuck valve (ON))	ON
18		Front outlet solenoid valve trouble (shorted or open, stuck valve (ON))	ON
19		ABS solenoid valve relay trouble (wiring shorted or open, stuck relay (ON or OFF))	ON
25		Front, rear tire abnormal (substandard tire, deformation wheel, sensor rotor teeth number wrong)	ON
35		ABS motor relay trouble (wiring shorted, open or lock, stuck relay (ON or OFF))	ON
42		Front wheel rotation sensor signal abnormal (sensor or rotor missing, too large clearance, rotor tooth worn or missing)	ON
43		Front wheel rotation sensor wiring abnormal (wiring shorted or open)	ON
44		Rear wheel rotation sensor signal abnormal (sensor or rotor missing, too large clearance, rotor tooth worn or missing)	ON
45		Rear wheel rotation sensor wiring abnormal (wiring shorted or open)	ON
52		Power supply voltage abnormal (under-voltage)	ON
53		Power supply voltage abnormal (over-voltage)	ON
55		ECU trouble (ECU operation abnormal)	ON

Anti-Lock Brake System (Equipped Models)

ABS Indicator Light (LED) Inspection

- Turn the ignition switch ON.
- ★ If the ABS indicator light (LED) [A] lights, it is normal.
- ★ If the ABS indicator light (LED) does not light, go to step "ABS Indicator Light (LED) is Unlit (When the Ignition Switch turned to ON)".

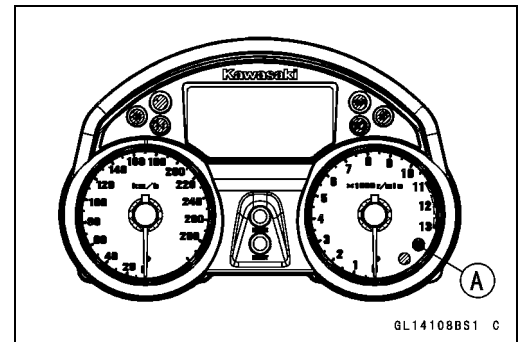

- Turn the ignition switch OFF.
- ★ If the ABS indicator light (LED) [A] does not light, it is normal.
- ★ If the ABS indicator light (LED) lights, go to step "ABS Indicator Light (LED) Lights (When the Motorcycle is Running, - No Service Code)".

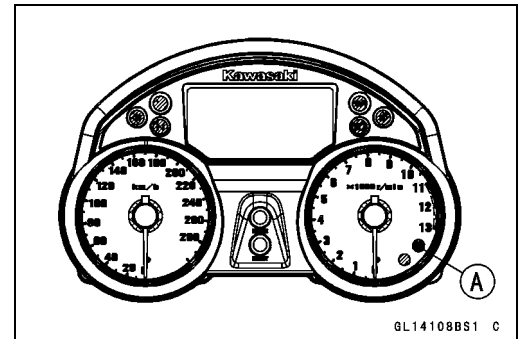

ABS Indicator Light (LED) is Unlit (When the Ignition Switch turned to ON)

- Do the 1st step test.
- Check the terminal voltage between the black/white lead terminal of the meter connector [A] and ground.

Special Tool - Hand Tester: 57001-1394

- Turn the ignition switch ON.

Terminal Voltage

Standard: About 10 V

- ★ If the terminal voltage is not within the specification, 2nd step.
- ★ If the terminal voltage correct, replace the meter assembly.
- Do the 2nd step test.
- Disconnect the meter connector.
- Check for continuity between the black/white lead terminal of the main harness side connector [A] and ground.
- ★ If there is the continuity in the lead, replace or repair the main harness.
- ★ If there is not the continuity in the lead, 3rd step.

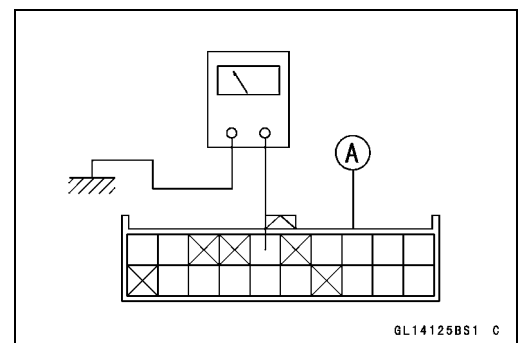
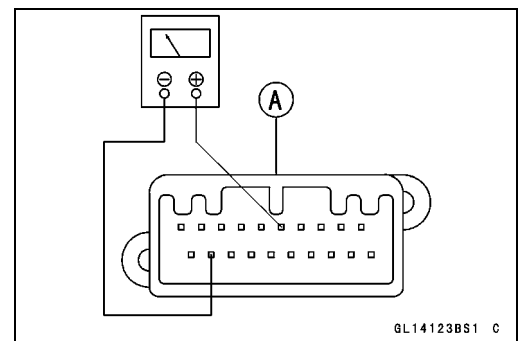

12-48 BRAKES

Anti-Lock Brake System (Equipped Models)

- Do the 3rd step test.
- Disconnect the ABS hydraulic unit connector.
- Check for continuity between the black/white lead terminal of the main harness side connector [A] and black/white lead terminal of the main harness side connector [B].
- ★ If there is the continuity in the lead, replace the ABS hydraulic unit.
- ★ If there is not the continuity in the lead, replace or repair the main harness.

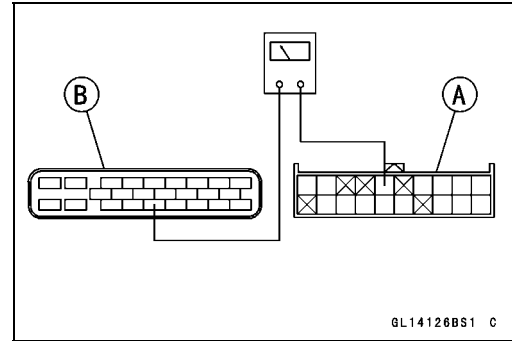

ABS Indicator Light (LED) Lights (When the Motorcycle is Running, - No Service Code)

- Do the 1st step test.
- Disconnect the ABS hydraulic unit connector and meter connector.
- Check for continuity between the black/white lead terminal of the main harness side connector [A] and black/white lead terminals of the main harness side connector [A].

Special Tool - Hand Tester: 57001-1394

- ★ If there is the continuity in the lead, replace the ABS hydraulic unit.
- ★ If there is not the continuity in the lead, replace or repair the main harness.

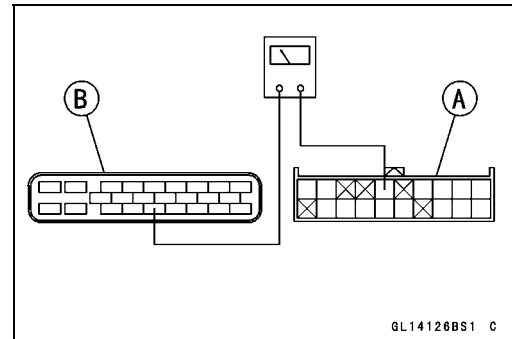

Solenoid Valve Inspection (Service Code 13,14,17,18)

- Do the 1st step test.
- Recheck the service code indication; erase the service code, perform the pre-diagnosis inspection 1 and 2, and retrieve the service code.
- ★ If the ABS indicator light (LED) [A] lit, faulty solenoid valve in the ABS hydraulic unit. Replace the ABS hydraulic unit.
- ★ If the ABS indicator light (LED) unlit, ABS system is normal (service code is not stored; temporary failure.).

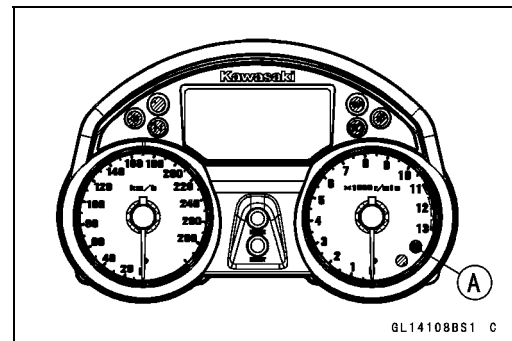

ABS Solenoid Valve Relay Inspection (Service Code 19)

- Do the 1st step test.
- Check the ABS solenoid valve relay fuse (20 A) [A].
- ★ If the fuse blown, 2nd step.
- ★ If the fuse correct, 4th step.



Anti-Lock Brake System (Equipped Models)

- Do the 2nd step test.
- Disconnect the ABS hydraulic unit connector [A].
- Check for continuity between the light green and black/yellow lead terminals of the ABS hydraulic unit connector.
- ★ If there is the continuity in the lead, replace the ABS hydraulic unit.
- ★ If there is not the continuity in the lead, 3rd step.

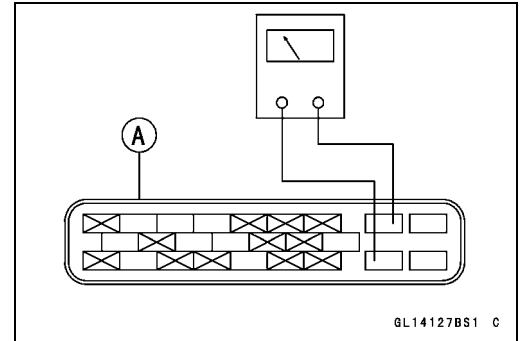

- Do the 3rd step test.
- Check for continuity between the light green lead terminal of the main harness side connector [A] and light green lead terminal of the fuse box [B].
- ★ If there is the continuity in the lead, replace the fuse.
- ★ If there is not the continuity in the lead, replace or repair the main harness.

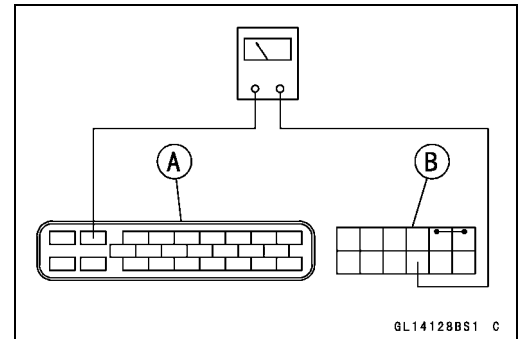

- Do the 4th step test.
- Check the battery terminal voltage between the light green lead terminal of the fuse box [A] and ground.

Special Tool - Hand Tester 57001-1394

Battery Terminal Voltage

Standard: Battery Voltage

- ★ If the battery terminal voltage is not within the specification, 5th step.
- ★ If the battery terminal voltage correct, 6th step.

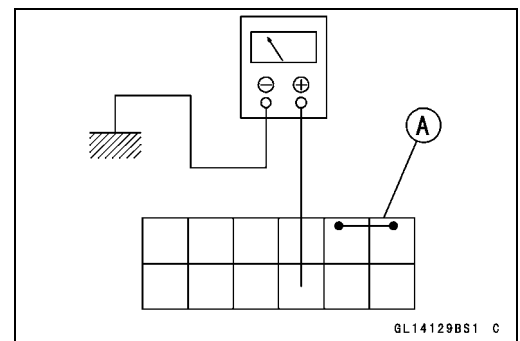

- Do the 5th step test.
- Check for continuity between the positive cable [A] of the battery and light green lead terminal of the main harness side connector [B].
- ★ If there is the continuity in the lead, 4th step.
- ★ If there is not the continuity in the lead, replace or repair the main harness.

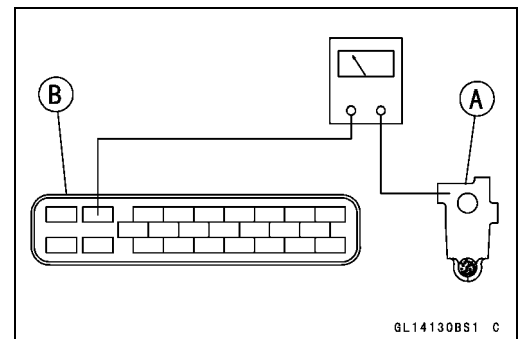

- Do the 6th step test.
- Recheck the service code indication; erase the service code, perform the pre-diagnosis inspection 1 and 2, and retrieve the service code.
- ★ If the ABS indicator light (LED) [A] lit, faulty ABS solenoid valve relay in the ABS hydraulic unit. Replace the ABS hydraulic unit.
- ★ If the ABS indicator light (LED) unlit, ABS system is normal (service code is not stored; temporary failure.).

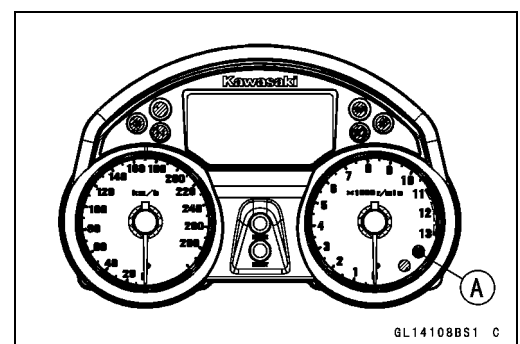

12-50 BRAKES

Anti-Lock Brake System (Equipped Models)

Front, Rear Wheel Rotation Difference Abnormal (Service Code 25)

- Do the 1st step test.
- Check the following and correct the faulty part.
 - Incorrect the tire pressure.
 - Tires not recommended for the motorcycle were installed (incorrect tire size).
 - Deformation of the wheel or tire.
 - Sensor rotor for missing teeth and clogging with foreign matter.
- ★ If the all parts correct, 2nd step.
- Do the 2nd step test.
- Recheck the service code indication; erase the service code, perform the pre-diagnosis inspection 1 and 2, and retrieve the service code.
- ★ If the ABS indicator light (LED) [A] lit, faulty ECU in the ABS hydraulic unit. Replace the ABS hydraulic unit.
- ★ If the ABS indicator light (LED) unlit, ABS system is normal (service code is not stored; temporary failure.).

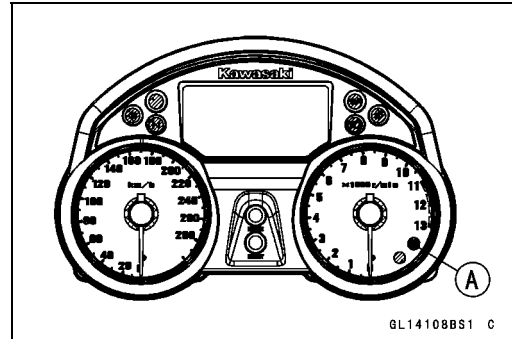

ABS Pump Motor Relay Inspection (Service Code 35)

- Do the 1st step test.
- Check the ABS pump motor relay fuse (30 A) [A].
- ★ If the fuse blown, 2nd step.
- ★ If the fuse correct, 4th step.
- Do the 2nd step test.
- Disconnect the ABS hydraulic unit connector.
- Check for continuity between the red and light blue lead terminals of the ABS hydraulic unit connector [A].
- ★ If there is the continuity in the lead, replace the ABS hydraulic unit.
- ★ If there is not the continuity in the lead, 3rd step.
- Do the 3rd step test.
- Check for continuity between the red lead terminal of the main harness side connector [A] and red lead terminal of the fuse box [B].
- ★ If there is the continuity in the lead, replace the fuse.
- ★ If there is not the continuity in the lead, replace or repair the main harness.

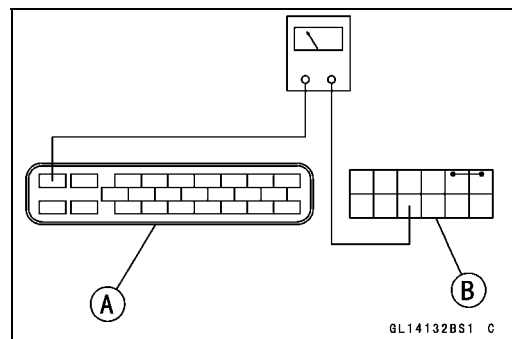
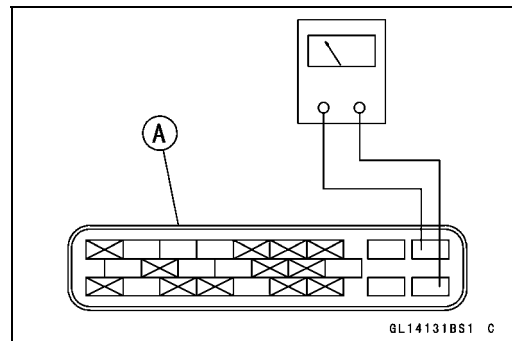
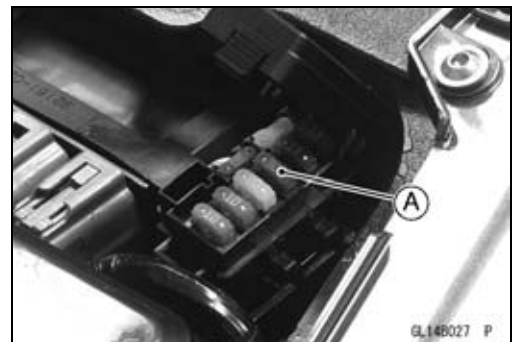

Anti-Lock Brake System (Equipped Models)

- Do the 4th step test.
- Check the battery terminal voltage between the red lead terminal of the fuse box [A] and ground.

Special Tool - Hand Tester: 57001-1394

Battery Terminal Voltage

Standard: Battery Voltage

- ★ If the battery terminal voltage is not within the specification, 5th step.
- ★ If the battery terminal voltage correct, 6th step.

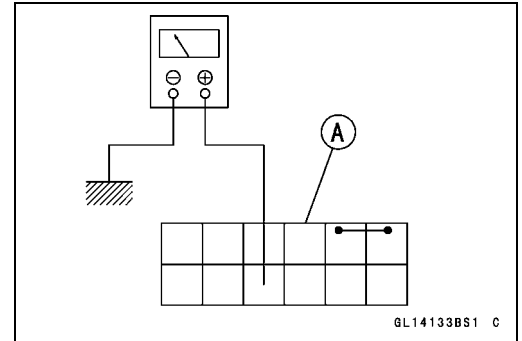

- Do the 5th step test.
- Check for continuity between the positive cable [A] of the battery and red lead terminal of the main harness side connector [B].
- ★ If there is the continuity in the lead, 4th step.
- ★ If there is not the continuity in the lead, replace or repair the main harness.

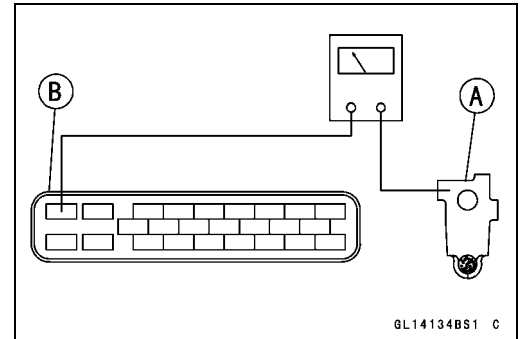

- Do the 6th step test.
- Recheck the service code indication; erase the service code, perform the pre-diagnosis inspection 1 and 2, and retrieve the service code.
- ★ If the ABS indicator light (LED) [A] lit, faulty ABS pump motor relay in the ABS hydraulic unit. Replace the ABS hydraulic unit.
- ★ If the ABS indicator light (LED) unlit, ABS system is normal (service code is not stored; temporary failure.).

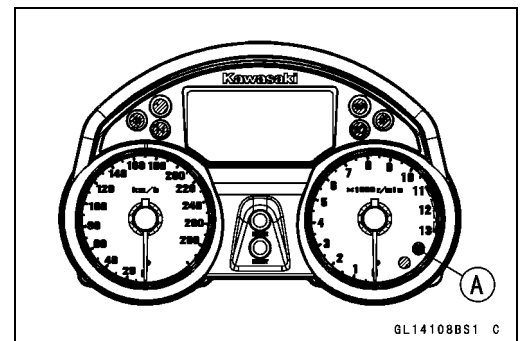

Front Wheel Rotation Sensor Signal Abnormal (Service Code 42)

- Do the 1st step test.
- Measure the air gap between the front wheel rotation sensor and sensor rotor.
Thickness Gauge [A]

Air Gap

Standard: 0.7 ~ 0.9 mm (0.028 ~ 0.035 in.)

- ★ If the measurement is over standard, check each part for deformation and looseness and correct accordingly. Recheck the air gap.
- ★ If the measurement is correct, 2nd step.



12-52 BRAKES

Anti-Lock Brake System (Equipped Models)

- Do the 2nd step test.
 - Check that there is iron or other magnetic deposits between the sensor [A] and sensor rotor [B], and the sensor rotor slots for obstructions.
 - Check the installation condition of the sensor for looseness.
 - Check the sensor and sensor rotor tip for deformation or damage (e.g., chipped sensor rotor teeth).
 - ★ If the sensor and sensor rotor in bad condition, remove the any deposits. Install the properly or replace faulty part.
 - ★ If the all correct, 3rd step.
-
- Do the 3rd step test.
 - Recheck the service code indication; erase the service code, perform the pre-diagnosis inspection 1 and 2, and retrieve the service code.
 - ★ If the ABS indicator light (LED) [A] lit, faulty ECU in the ABS hydraulic unit. Replace the ABS hydraulic unit.
 - ★ If the ABS indicator light (LED) unlit, ABS system is normal (service code is not stored; temporary failure.).

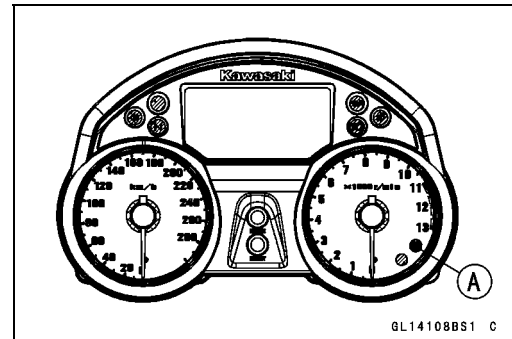
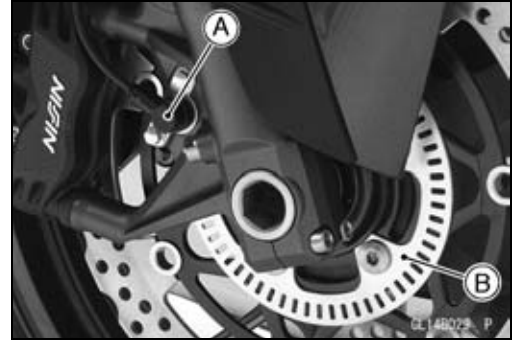

Front Wheel Rotation Sensor Wiring Inspection (Service Code 43)

- Do the 1st step test.
 - Disconnect the ABS hydraulic unit connector and front wheel rotation sensor connector.
 - Short the brown and green lead terminals of the main harness side connector [A] with a jumper lead, and check for continuity between the brown and green lead terminals of the main harness side connector [B].
 - ★ If there is the continuity in the lead, 2nd step.
 - ★ If there is not the continuity in the lead, replace or repair the main harness.
-
- Do the 2nd step test.
 - Check for continuity between the black lead terminal of the sensor connector [A] and ground, and white lead terminal of the sensor connector and ground.
 - ★ If there is the continuity in the lead, replace the front wheel rotation sensor.
 - ★ If there is not the continuity in the lead, 3rd step.

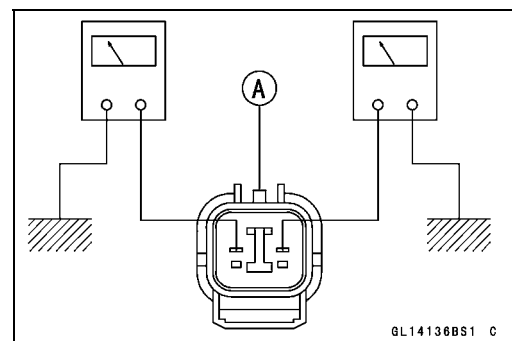
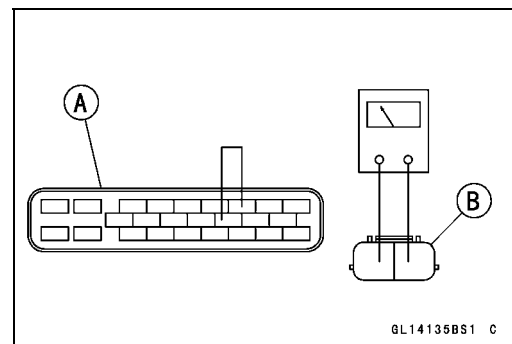

Anti-Lock Brake System (Equipped Models)

- Do the 3rd step test.
- Recheck the service code indication; erase the service code, perform the pre-diagnosis inspection 1 and 2, and retrieve the service code.
- ★ If the ABS indicator light (LED) [A] lit, faulty ECU in the ABS hydraulic unit. Replace the ABS hydraulic unit.
- ★ If the ABS indicator light (LED) unlit, ABS system is normal (service code is not stored; temporary failure.).

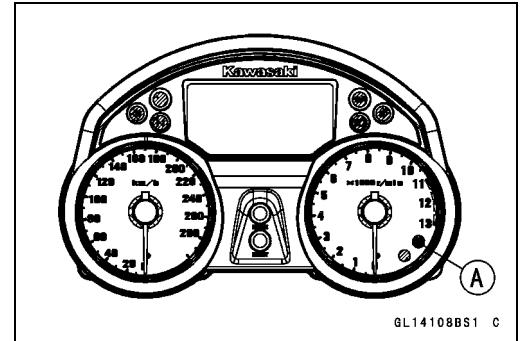

Rear Wheel Rotation Sensor Signal Abnormal (Service Code 44)

- Do the 1st step test.
- Measure the air gap between the rear wheel rotation sensor and sensor rotor.
Thickness Gauge [A]

Air Gap

Standard: 0.7 ~ 0.9 mm (0.028 ~ 0.035 in.)

- ★ If the measurement is over standard, check each part for deformation and looseness and correct accordingly. Recheck the air gap.
- ★ If the measurement is correct, 2nd step.



- Do the 2nd step test.
- Check that there is iron or other magnetic deposits between the sensor [A] and sensor rotor [B], and the sensor rotor slots for obstructions.
- Check the installation condition of the sensor for looseness.
- Check the sensor and sensor rotor tip for deformation or damage (e.g., chipped sensor rotor teeth).
- ★ If the sensor and sensor rotor in bad condition, remove the any deposits. Install the properly or replace faulty part.
- ★ If the all correct, 3rd step.

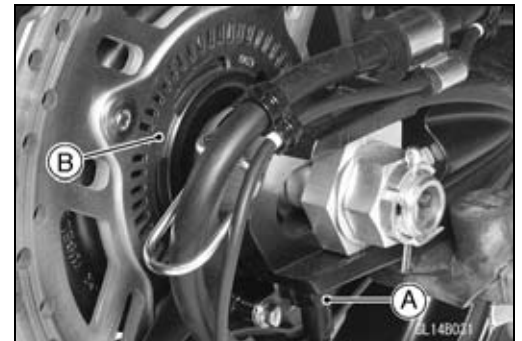

- Do the 3rd step test.
- Recheck the service code indication; erase the service code, perform the pre-diagnosis inspection 1 and 2, and retrieve the service code.
- ★ If the ABS indicator light (LED) [A] lit, faulty ECU in the ABS hydraulic unit. Replace the ABS hydraulic unit.
- ★ If the ABS indicator light (LED) unlit, ABS system is normal (service code is not stored; temporary failure.).

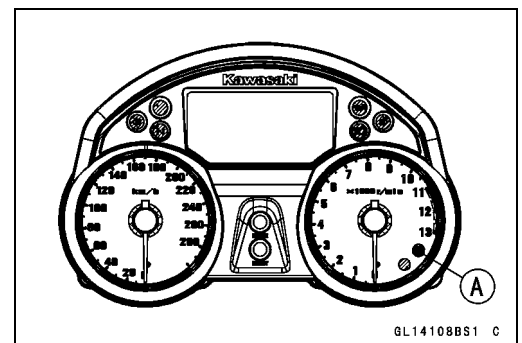

12-54 BRAKES

Anti-Lock Brake System (Equipped Models)

Rear Wheel Rotation Sensor Wiring Inspection (Service Code 45)

- Do the 1st step test.
- Disconnect the ABS hydraulic unit connector and rear wheel rotation sensor connector.
- Short the black and white/red lead terminals of the main harness side connector [A] with a jumper lead, and check for continuity between the black and white/red lead terminals of the main harness side connector [B].
- ★ If there is the continuity in the lead, 2nd step.
- ★ If there is not the continuity in the lead, replace or repair the main harness.

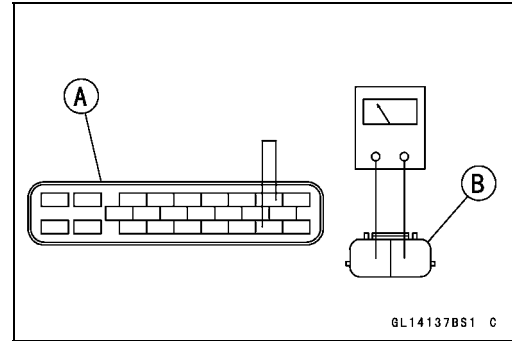

- Do the 2nd step test.
- Check for continuity between the black lead terminal of the sensor connector [A] and ground, and white lead terminal of the sensor connector and ground.
- ★ If there is the continuity in the lead, replace the rear wheel rotation sensor.
- ★ If there is not the continuity in the lead, 3rd step.

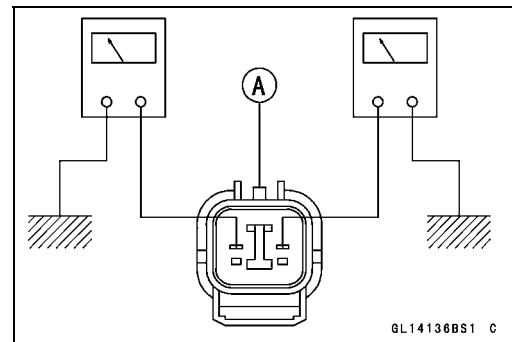

- Do the 3rd step test.
- Recheck the service code indication; erase the service code, perform the pre-diagnosis inspection 1 and 2, and retrieve the service code.
- ★ If the ABS indicator light (LED) [A] lit, faulty ECU in the ABS hydraulic unit. Replace the ABS hydraulic unit.
- ★ If the ABS indicator light (LED) unlit, ABS system is normal (service code is not stored; temporary failure.).

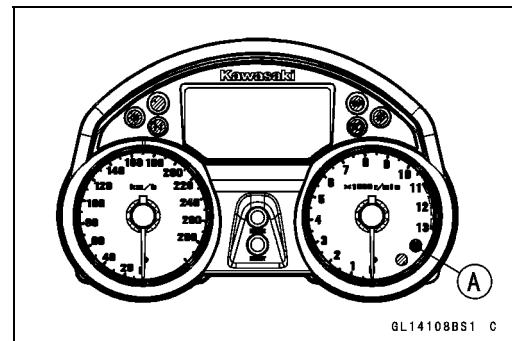

Power Supply Voltage Abnormal (Under-Voltage) (Service Code 52)

- Do the 1st step test.
- Disconnect the ignition switch connector and ABS hydraulic unit connector.
- Check for continuity between the brown lead terminal of the main harness side connector [A] and yellow lead terminal of the main harness side connector [B].
- ★ If there is the continuity in the lead, 2nd step.
- ★ If there is not the continuity in the lead, inspect the ABS ECU fuse (10 A) (see Fuse Inspection in the Electrical System chapter) and replace or repair the main harness.

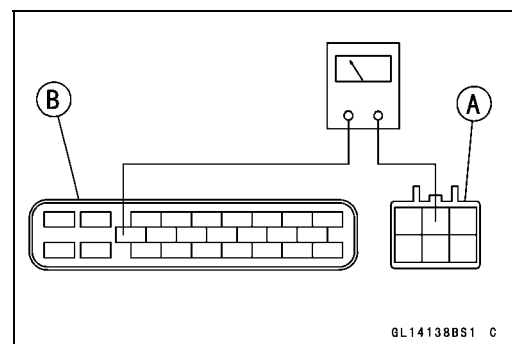

Anti-Lock Brake System (Equipped Models)

- Do the 2nd step test.
- Connect the ignition switch connector and ABS hydraulic unit connector.
- Check the battery terminal voltage, connect the hand tester to the brown terminal of ignition switch connector [A] and ground.

Special Tool - Hand Tester: 57001-1394

- Turn the ignition switch ON.

Battery Terminal Voltage

Standard: 10 V or more

- ★ If the battery terminal voltage is not within the specification, 3rd step.
- ★ If the battery terminal voltage correct, 4th step.

- Do the 3rd step test.

- Inspect the following parts.

Battery (see Charging Condition Inspection in the Electrical System chapter)

Ignition Switch (see Switch Inspection in the Electrical System chapter)

Main Harness (see Wiring Inspection in the Electrical System chapter)

Main Fuse 30 A (see Fuse Inspection in the Electrical System chapter)

- Do the 4th step test.

- Recheck the service code indication; erase the service code, perform the pre-diagnosis inspection 1 and 2, and retrieve the service code.

★ If the ABS indicator light (LED) [A] lit, faulty ECU in the ABS hydraulic unit. Replace the ABS hydraulic unit.

★ If the ABS indicator light (LED) unlit, ABS system is normal (service code is not stored; temporary failure.).

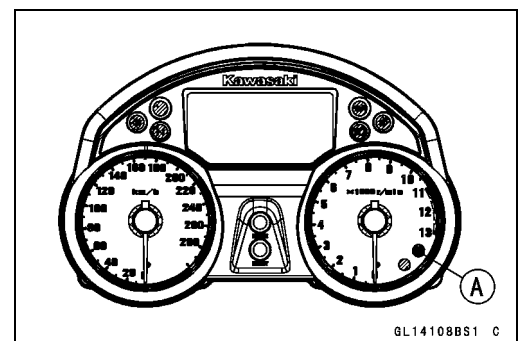
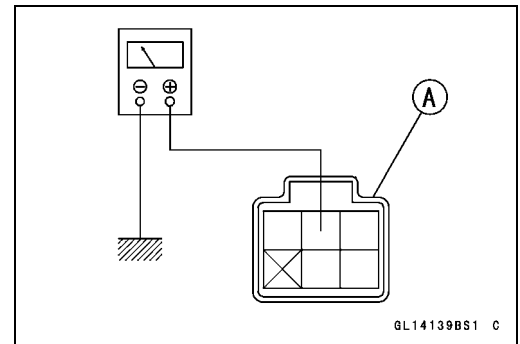

Power Supply Voltage Abnormal (Over-Voltage) (Service Code 53)

- Do the 1st step test.
- Disconnect the ignition switch connector and ABS hydraulic unit connector.
- Check for continuity between the brown lead terminal of the main harness side connector [A] and yellow lead terminal of the main harness side connector [B].

★ If there is the continuity in the lead, 2nd step.

★ If there is not the continuity in the lead, inspect the ABS ECU fuse (10 A) (see Fuse Inspection in the Electrical System chapter) and replace or repair the main harness.

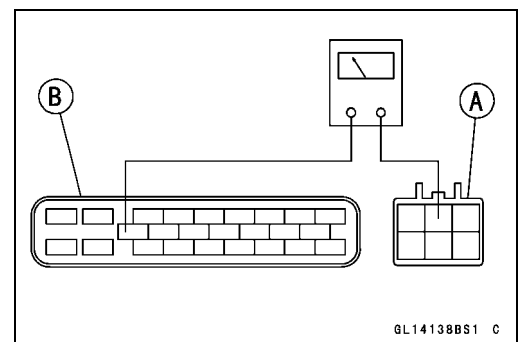

12-56 BRAKES

Anti-Lock Brake System (Equipped Models)

- Do the 2nd step test.
- Connect the ignition switch connector and ABS hydraulic unit connector.
- Check the battery terminal voltage, connect the hand tester to the brown terminal of ignition switch connector [A] and ground.

Special Tool - Hand Tester: 57001-1394

- Turn the ignition switch ON.

Battery Terminal Voltage

Standard: 16 V or less

- ★ If the battery terminal voltage is not within the specification, 3rd step.
- ★ If the battery terminal voltage correct, 4th step.

- Do the 3rd step test.
- Check the battery condition and regulator/rectifier (see Charging Condition Inspection, Regulator/Rectifier Inspection in the Electrical System chapter).

- Do the 4th step test.
- Recheck the service code indication; erase the service code, perform the pre-diagnosis inspection 1 and 2, and retrieve the service code.
- ★ If the ABS indicator light (LED) [A] lit, faulty ECU in the ABS hydraulic unit. Replace the ABS hydraulic unit.
- ★ If the ABS indicator light (LED) unlit, ABS system is normal (service code is not stored; temporary failure.).

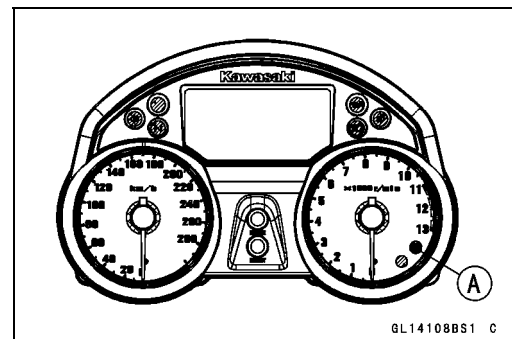
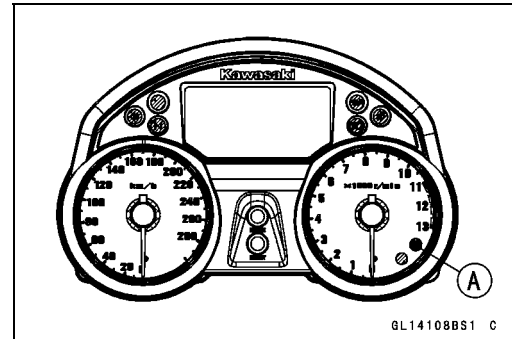
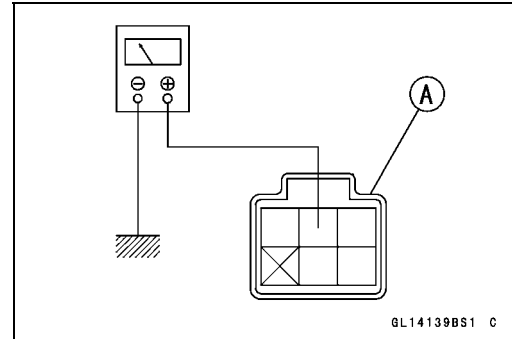

ECU Inspection (Service Code 55)

- Do the 1st step test.
- Recheck the service code indication; erase the service code, perform the pre-diagnosis inspection 1 and 2, and retrieve the service code.
- ★ If the ABS indicator light (LED) [A] lit, faulty ECU in the ABS hydraulic unit. Replace the ABS hydraulic unit.
- ★ If the ABS indicator light (LED) unlit, ABS system is normal (service code is not stored; temporary failure.).

ABS Hydraulic Unit Removal

CAUTION

The ABS hydraulic unit [A] has been adjusted and set with precision at the factory. Therefore, it should be handled carefully, never struck sharply, as with a hammer, or allowed to fall on a hard surface.

Be careful not to get water or mud on the ABS hydraulic unit.

- Drain the brake fluid from the front and rear brake lines.
- Drain the brake fluid through the bleed valve by pumping the brake lever and pedal.

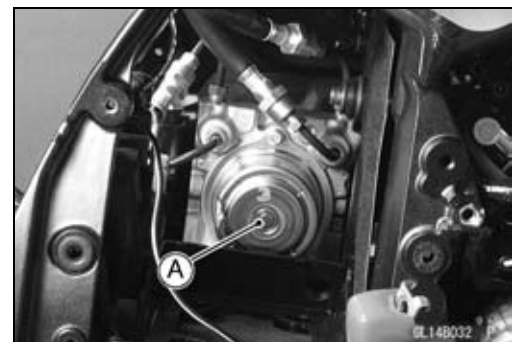

Anti-Lock Brake System (Equipped Models)

- Remove:
 - Fuel Tank (see Fuel Tank Removal in the Fuel System (DFI) chapter)
 - Battery (see Battery Removal in the Electrical System chapter)
 - Bolts [A]
 - Cover [B]
- Clean the ABS hydraulic unit.

CAUTION

Clean all fittings on the ABS hydraulic unit and the rear master cylinder because dirt around the banjo bolts could contaminate the brake fluid in the line during removal/installation.

Spread out a shop towel around the ABS hydraulic unit before removing the brake line so that brake fluid does not leak on the parts.

- Remove the brake pipe joint nuts [A] [B] [C] [D].
- Tape the brake line opening to prevent brake fluid leakage or contamination by foreign matter.

CAUTION

Brake fluid quickly ruins painted plastic surfaces; any spilled fluid should be completely washed away immediately.

- Disconnect the connector [A].
- Unlock the joint lock [B] as shown in the figure.

- Remove the bolts [A].
- Remove the ABS hydraulic unit with bracket.

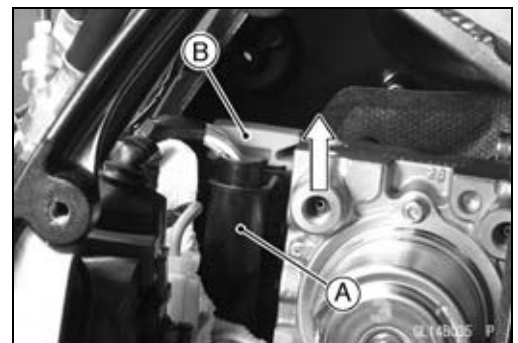
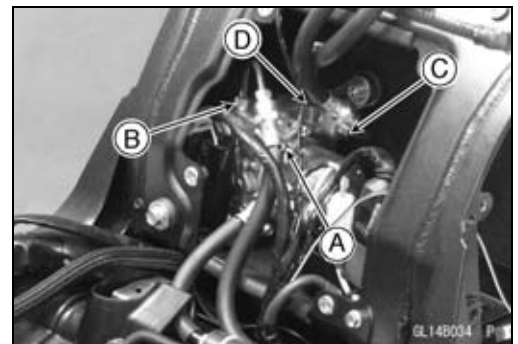
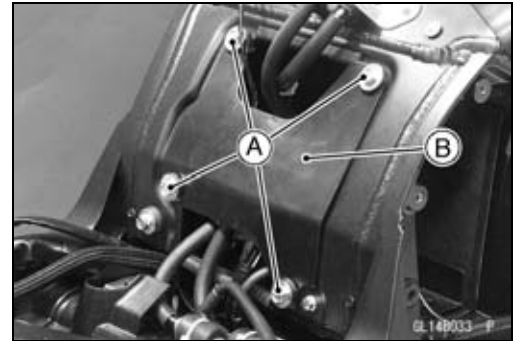

12-58 BRAKES

Anti-Lock Brake System (Equipped Models)

- Remove the bolts [A] and bracket [B].

CAUTION

The ABS hydraulic unit has been adjusted and set with precision at the factory. Do not try to disassemble and repair the ABS hydraulic unit.

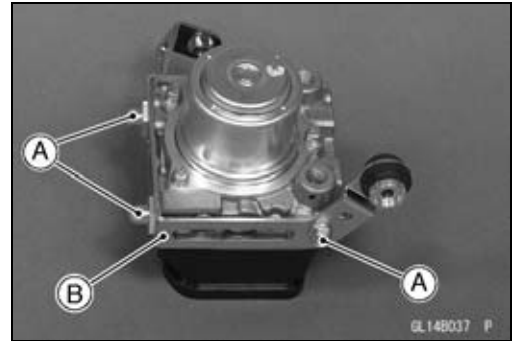

ABS Hydraulic Unit Installation

- Install the ABS hydraulic unit to the bracket.

CAUTION

Brake fluid quickly ruins painted plastic surfaces; any spilled fluid should be completely washed away immediately.

- Insert the bolts [A] into the grommets [B].
- Route the lead correctly, and connector [A] securely.
- Lock the joint lock [B] as shown in the figure.

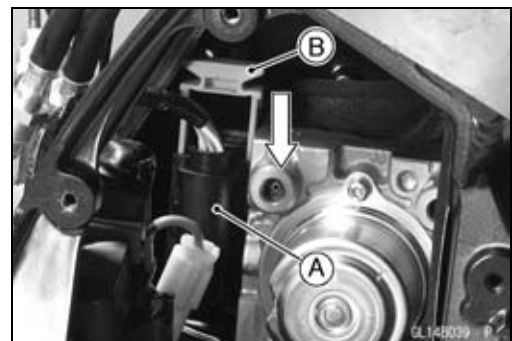
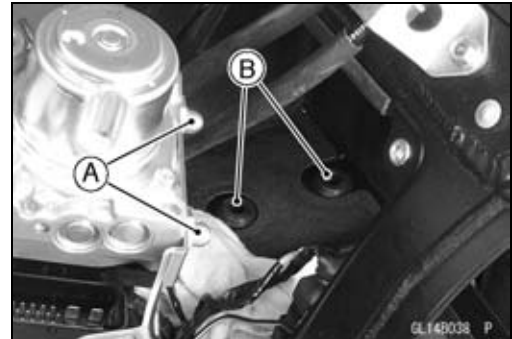

- Install the brake pipes correctly as shown in the figure.
 - 48° [A]
 - 71° [B]
 - 30° [C]
 - 38.5° [D]
- Tighten the joint nuts.
Torque - Brake Pipe Joint Nuts: 18 N·m (1.8 kgf·m, 13 ft·lb)
- Bleed the brake line (see Brake Line Bleeding).
- Check the brake for good braking power, no brake drag, and no fluid leakage.
- Install the removed parts (see appropriate chapters).

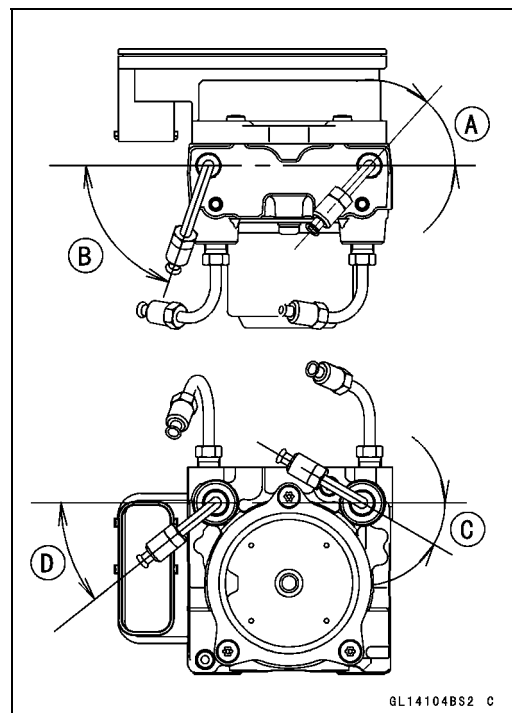

Anti-Lock Brake System (Equipped Models)

ABS Hydraulic Unit Inspection

- Remove the ABS hydraulic unit (see ABS Hydraulic Unit Removal).
- Visually inspect the ABS hydraulic unit.
- ★ Replace the ABS hydraulic unit if any of them are cracked, or otherwise damaged.

- Visually inspect the connector terminals [A].
- ★ Replace the ABS hydraulic unit or main harness if either of the terminals are cracked, bent, or otherwise damaged.
- ★ If the ABS hydraulic unit connector is clogged with mud or dust, blow it off with compressed air.



Front Wheel Rotation Sensor Removal

CAUTION

The wheel rotation sensor should be handled carefully, never struck sharply, as with a hammer, or allowed to fall on a hard surface since the wheel rotation sensor is precision made. Be careful not to get water or mud on the wheel rotation sensor. Do not try to disassemble or repair the wheel rotation sensor.

- Remove:
 - Left Middle Fairing (see Middle Fairing Removal in the Frame chapter)
 - Connector [A] (Disconnect)
 - Clamps [B]

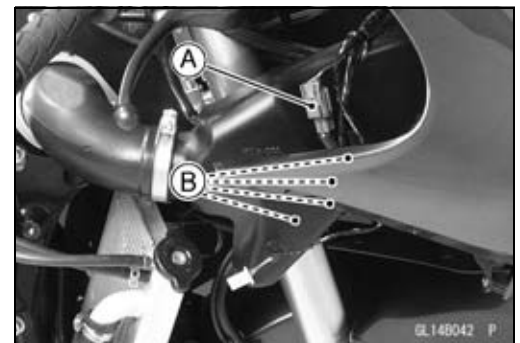

- Remove:
 - Bolts [A]
 - Bracket Bolt [B]
 - Clamps [C]
 - Front Wheel Rotation Sensor [D]

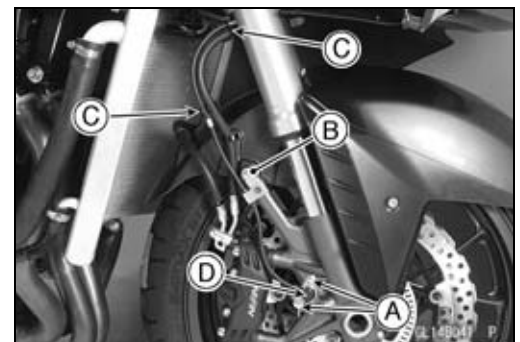

Front Wheel Rotation Sensor Installation

- Installation is the reverse of removal.
- Route the lead correctly (see Cable, Wire, and Hose Routing section in the Appendix chapter).

12-60 BRAKES

Anti-Lock Brake System (Equipped Models)

Rear Wheel Rotation Sensor Removal

CAUTION

The wheel rotation sensor should be handled carefully, never struck sharply, as with a hammer, or allowed to fall on a hard surface since the wheel rotation sensor is precision made. Be careful not to get water or mud on the wheel rotation sensor. Do not try to disassemble or repair the wheel rotation sensor.

- Remove:
 - Fuel Tank (see Fuel Tank Removal in the Fuel System (DFI) chapter)
 - Connector [A] (Disconnect)
- Clear the connector from the bracket.

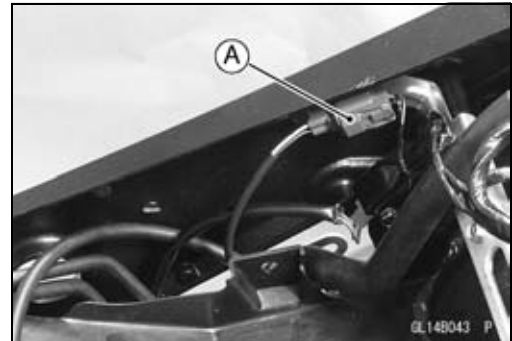

- Remove:
 - Bracket Bolts [A]
 - Clamps [B]
 - Bolts [C]
 - Rear Wheel Rotation Sensor [D]

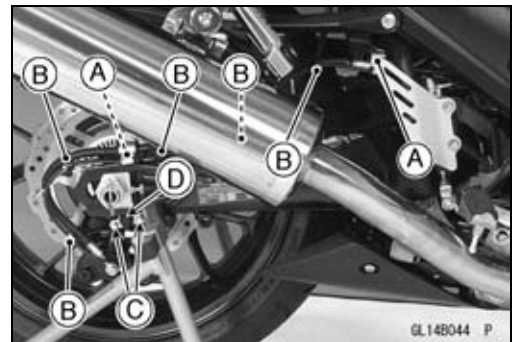

Rear Wheel Rotation Sensor Installation

- Installation is the reverse of removal.
- Route the lead correctly (see Cable, Wire, and Hose Routing section in the Appendix chapter).

Anti-Lock Brake System (Equipped Models)

Wheel Rotation Sensor Inspection

- Remove the front wheel rotation sensor [A] from the front fork.
- Remove the rear wheel rotation sensor [B] from the caliper bracket.
- Visually inspect the wheel rotation sensors.
- ★ Replace the wheel rotation sensor if it is cracked, bent, or otherwise damaged.



Wheel Rotation Sensor Air Gap Inspection

- Raise the front/rear wheel off the ground (see Front/Rear Wheel Removal in the Wheels/Tires chapter).
- Measure the air gap between the sensor and sensor rotor at several points by turning the wheel slowly.
Thickness Gauge [A]

Air Gap

Standard:

Front	0.7 ~ 0.9 mm (0.028 ~ 0.035 in.)
Rear	0.7 ~ 0.9 mm (0.028 ~ 0.035 in.)

NOTE

○ The sensor air gap cannot be adjusted.

- ★ If the air gap is not within the specification, inspect the hub bearing (see Hub Bearing Inspection in the Wheels/Tires chapter), sensor installation condition and sensor (see Wheel Rotation Sensor Inspection).

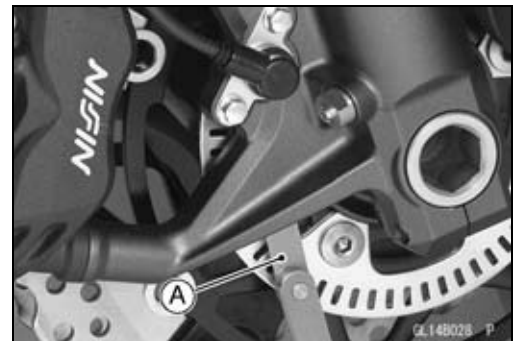

12-62 BRAKES

Anti-Lock Brake System (Equipped Models)

Wheel Rotation Sensor Rotor Inspection

- Remove:
 - Wheels (see Front/Rear Wheel Removal in the Wheels/Tires chapter)
 - Brake Disc Mounting Bolts [A]
 - Sensor Rotor [B]

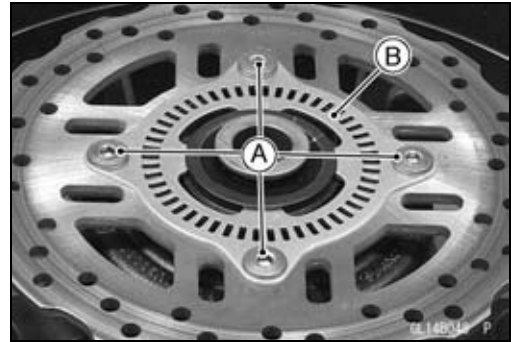
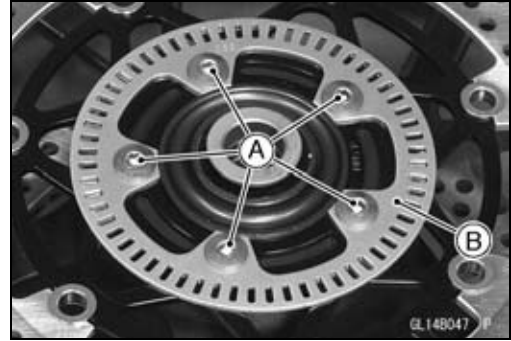

- Visually inspect the wheel rotation sensor rotor.
- ★ If the rotor is deformed or damaged (chipped teeth [A]), replace the sensor rotor with a new one.
- ★ If there is iron or other magnetic deposits [B], remove the deposits.

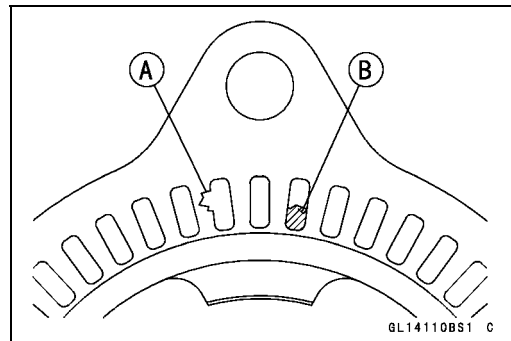
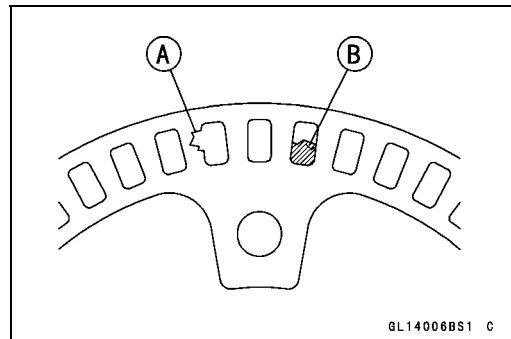

ABS Solenoid Valve Relay Fuse (20 A) Removal

- Refer to the Fuse Box Fuse Removal in the Electrical System chapter.

ABS Motor Relay Fuse (30 A) Removal

- Refer to the Fuse Box Fuse Removal in the Electrical System chapter.

ABS ECU Fuse (10 A) Removal

- Refer to the Fuse Box Fuse Removal in the Electrical System chapter.

Anti-Lock Brake System (Equipped Models)

Fuse Installation

- If a fuse fails during operation, inspect the electrical system to determine the cause, and then replace it with a new fuse of proper amperage (see Fuse Installation in the Electrical System chapter).

Fuse Inspection

- Remove the fuses (see ABS Solenoid Valve Relay Fuse (20 A) /ABS Motor Relay Fuse (30 A) Removal).
- Refer to the Fuse Inspection in the Electrical System chapter.

Suspension

Table of Contents

Exploded View	13-2
Specifications	13-6
Special Tools	13-7
Front Fork	13-9
Rebound Damping Force Adjustment	13-9
Compression Damping Force Adjustment	13-9
Spring Preload Adjustment	13-10
Front Fork Removal (Each Fork Leg)	13-10
Front Fork Installation	13-11
Front Fork Oil Change	13-11
Front Fork Disassembly	13-16
Front Fork Assembly	13-16
Inner Tube Inspection	13-17
Dust Seal Inspection	13-18
Spring Tension	13-18
Rear Shock Absorber	13-19
Rebound Damping Force Adjustment	13-19
Compression Damping Force Adjustment	13-19
Spring Preload Adjustment	13-19
Rear Shock Absorber Removal	13-20
Rear Shock Absorber Installation	13-21
Rear Shock Absorber Inspection	13-21
Rear Shock Absorber Scrapping	13-22
Swingarm	13-23
Swingarm Removal	13-23
Swingarm Installation	13-24
Swingarm Bearing Removal	13-25
Swingarm Bearing Installation	13-25
Swingarm Bearing, Sleeve Inspection	13-26
Chain Guide Inspection	13-27
Tie-Rod, Rocker Arm	13-28
Tie-Rod Removal	13-28
Tie-Rod Installation	13-28
Rocker Arm Removal	13-28
Rocker Arm Installation	13-29
Tie-Rod and Rocker Arm Bearing Removal	13-29
Tie-Rod and Rocker Arm Bearing Installation	13-29
Rocker Arm/Tie-Rod Bearing, Sleeve Inspection	13-31
Rocker Arm/Tie-Rod Bearing Lubrication	13-31

13-2 SUSPENSION

Exploded View

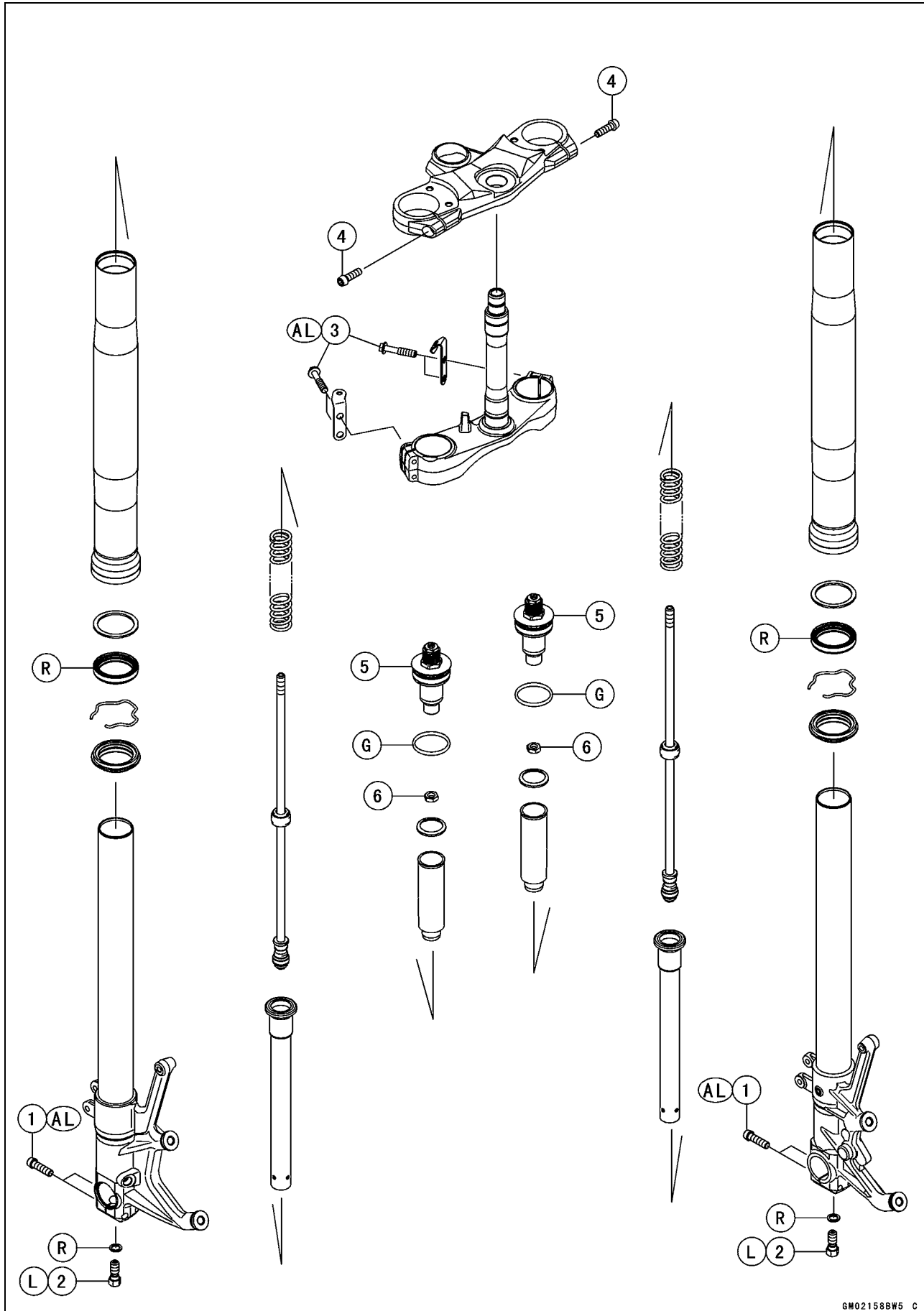

Exploded View

No.	Fastener	Torque			Remarks
		N·m	kgf·m	ft·lb	
1	Front Axle Clamp Bolts	20	2.0	15	AL
2	Front Fork Bottom Allen Bolts	23	2.3	17	L
3	Front Fork Clamp Bolts (Lower)	30	3.1	22	AL
4	Front Fork Clamp Bolts (Upper)	20	2.0	15	
5	Front Fork Top Plugs	22	2.2	16	
6	Piston Rod Nuts	28	2.9	21	

AL: Tighten the two clamp bolts alternately two times to ensure even tightening torque.

G: Apply grease.

L: Apply a non-permanent locking agent.

R: Replacement Parts

Exploded View

No.	Fastener	Torque			Remarks
		N·m	kgf·m	ft·lb	
1	Rear Shock Absorber Nut (Lower)	34	3.5	25	
2	Rear Shock Absorber Nut (Upper)	34	3.5	25	
3	Swingarm Pivot Adjusting Collar	20	2.0	15	
4	Swingarm Pivot Adjusting Collar Locknut	98	10.0	72	
5	Swingarm Pivot Shaft Nut	108	11.0	80	
6	Tie-Rod Nuts	59	6.0	44	
7	Uni-Trak Rocker Arm Nut	34	3.5	25	

G: Apply grease.

R: Replacement Parts

13-6 SUSPENSION

Specifications

Item	Standard
Front Fork (Per One Unit)	
Fork Inner Tube Diameter	φ43 mm (1.7 in.)
Air Pressure	Atmospheric pressure (non-adjustable)
Rebound Damper Setting	5th click from the 1st click of the fully clockwise position (Usable range: 0 ↔ 11 clicks)
Compression Damper Setting	10th click from the 1st click of the fully clockwise position (Usable range: 0 ↔ 13 clicks)
Fork Spring Preload Setting	Adjuster protrusion is 15 mm (0.59 in.) (Usable range: 4 ~ 19 mm) (0.16 ~ 0.75 in.)
Fork Oil: Viscosity Amount	KAYABA 01 (KHL15-10) or equivalent SAE 5W Approx. 480 mL (16.2 US oz.) (when changing oil) 563 ±4 mL (19.0 ±0.14 US oz.) (after disassembly and completely dry)
Fork Oil Level	88 ±2 mm (3.46 ±0.08 in.) (fully compressed, without fork spring, below from inner tube top)
Fork Spring Free Length	257 mm (10.12 in.) (Service Limit: 252 mm (9.92 in.))
Rear Shock Absorber	
Rebound Damper Set	1 2/4 turns out from the fully clockwise position (Usable range: 0 ↔ 2 2/4 turns out)
Compression Damper Set	2 1/4 turns out from the fully clockwise position (Usable range: 0 ↔ 4 turns out)
Spring Preload Setting Position: Standard Usable Range	Spring length: 175.5 mm (6.9 in.) Spring length: 175.5 ~ 191.5 mm (6.909 ~ 7.539 in.) (weaker to stronger)
Gas Pressure	1 080 kPa (11.0 kgf/cm ² , 156 psi, non-adjustable)

Special Tools

Inside Circlip Pliers:
57001-143

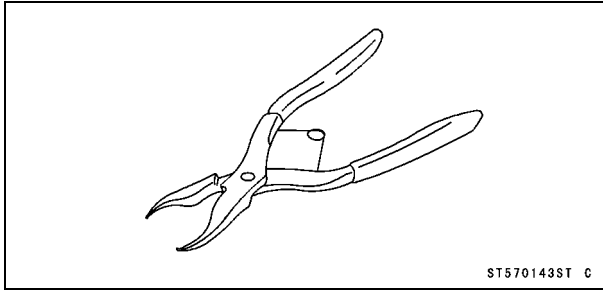

Fork Piston Rod Puller, M12 × 1.25:
57001-1289

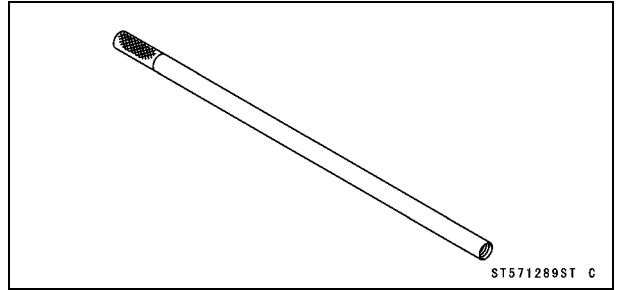

Oil Seal & Bearing Remover:
57001-1058

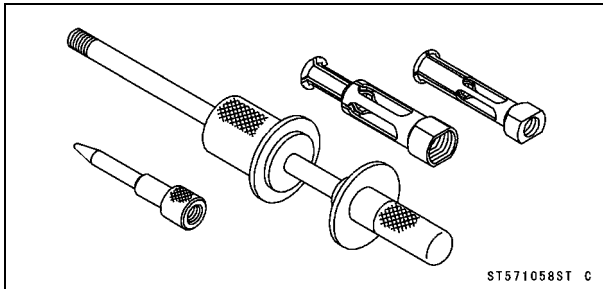

Fork Oil Level Gauge:
57001-1290

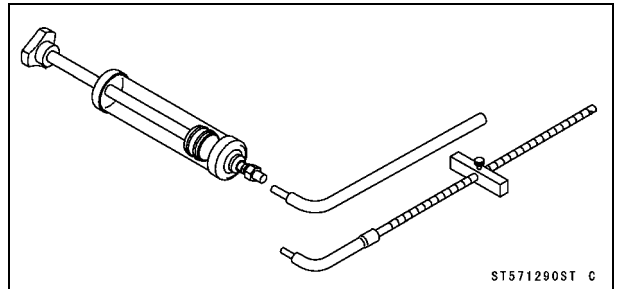

Bearing Driver Set:
57001-1129

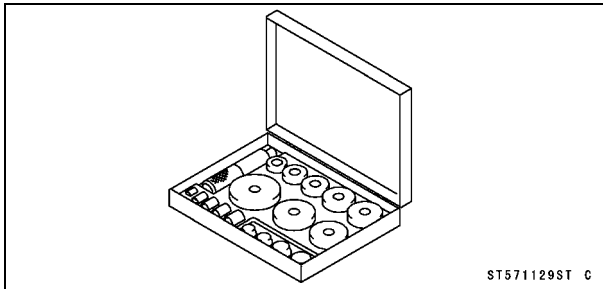

Bearing Remover Head, $\phi 20 \times \phi 22$:
57001-1293

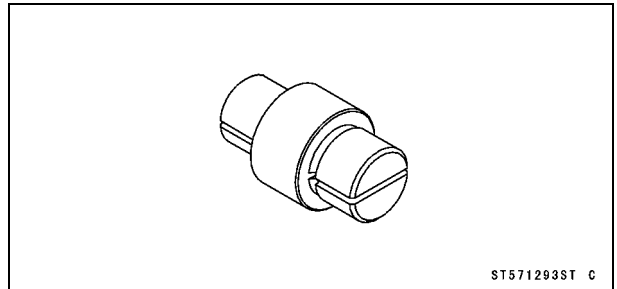

Jack:
57001-1238

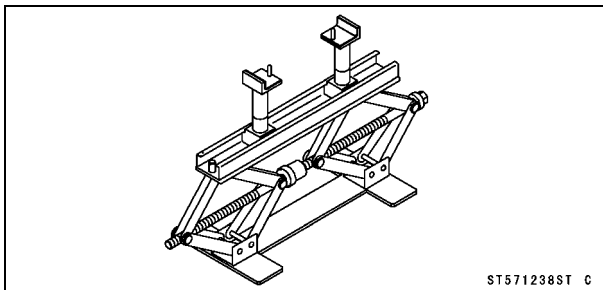

Bearing Remover Shaft, $\phi 13$:
57001-1377

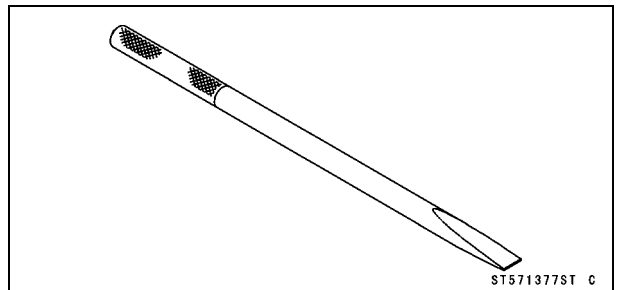

Fork Cylinder Holder:
57001-1287

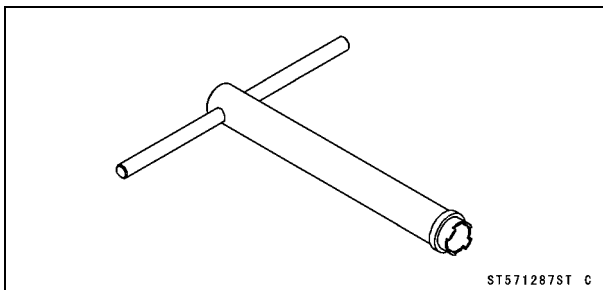

Hook Wrench T=3.2 R37:
57001-1522

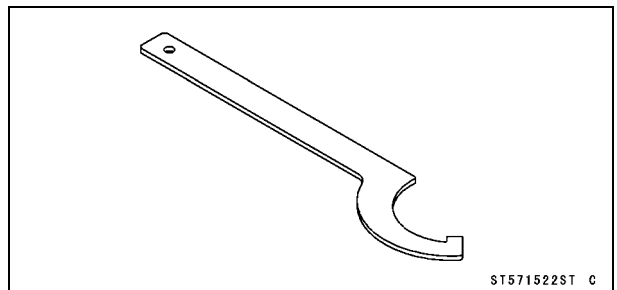

13-8 SUSPENSION

Special Tools

Fork Oil Seal Driver, $\phi 43$:
57001-1530

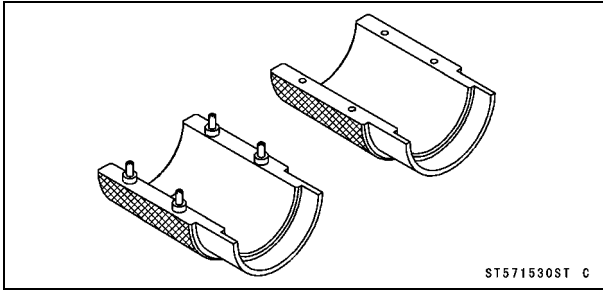

Needle Bearing Driver, $\phi 17/\phi 18$:
57001-1609

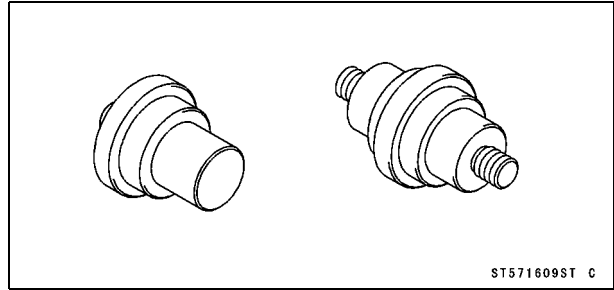

Fork Spring Compressor:
57001-1540

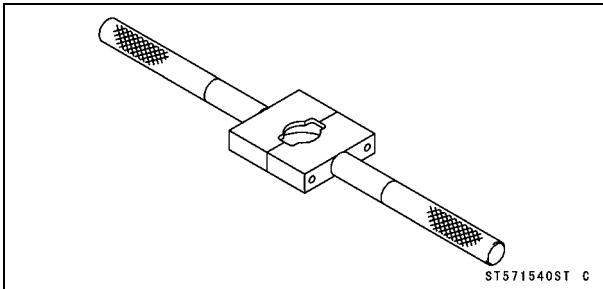

Stem Bearing Driver, $\phi 28$:
57001-1610

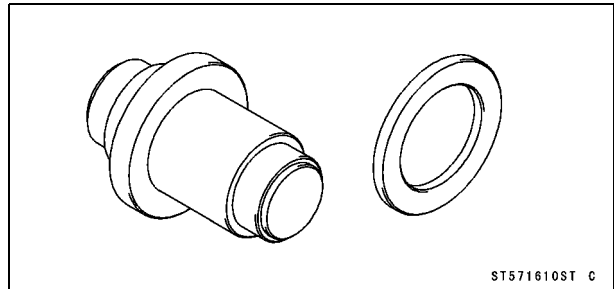

Fork Spring Compressor:
57001-1587

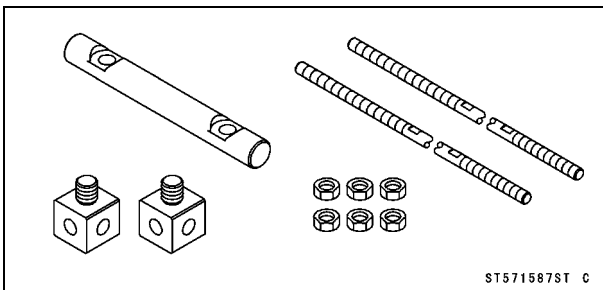

Spacer, $\phi 18$:
57001-1636

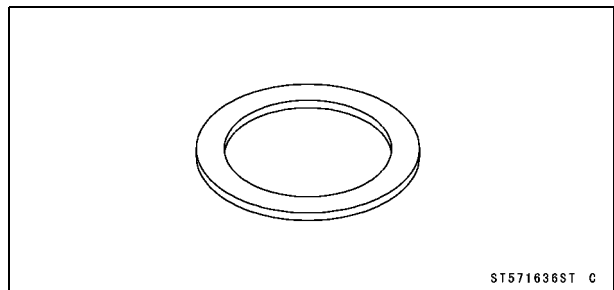

Swingarm Pivot Nut Wrench:
57001-1597

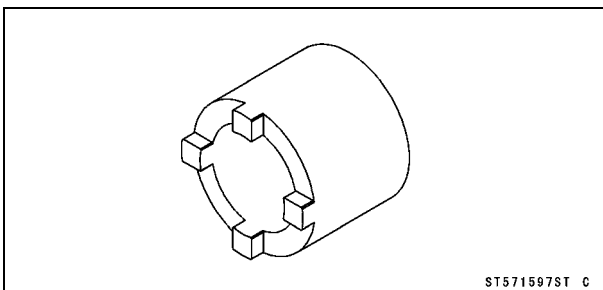

Spacer $\phi 28$:
57001-1663

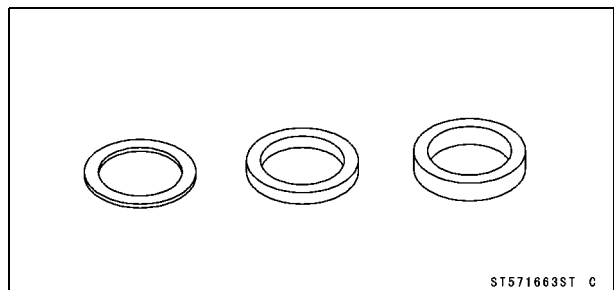

Jack Attachment:
57001-1608

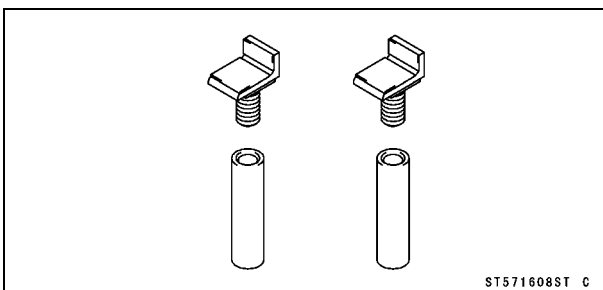

Needle Bearing Driver, $\phi 20$ & Spacer, $\phi 28$:
57001-1678

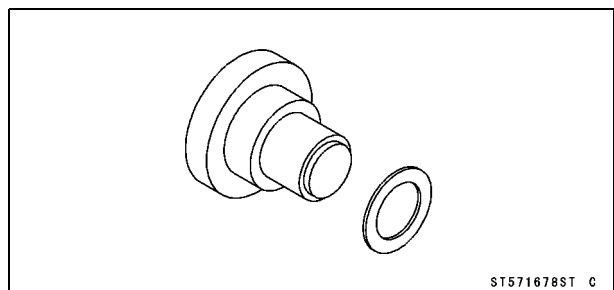

Front Fork

Rebound Damping Force Adjustment

- To adjust the rebound damping force, turn the rebound damping adjuster [A] until you feel a click.
- The standard adjuster setting for the average-build rider of 68 kg (150 lb) with no passenger and no accessories is the **5th click** from the 1st click of the fully clockwise position.

⚠ WARNING

If both adjusters are not adjusted equally, handling may be impaired and a hazardous condition may result.

- The damping force can be left soft for average riding. But it should be adjusted harder for high speed riding or riding with a passenger. If the damping feels too soft or too stiff, adjust it in accordance with the following table.

Rebound Damping Force Adjustment

Adjuster Position	Damping Force	Setting	Load	Road	Speed
11	Weak	Soft	Light	Good	Low
↑	↑	↑	↑	↑	↑
↓	↓	↓	↓	↓	↓
0	Strong	Hard	Heavy	Bad	High

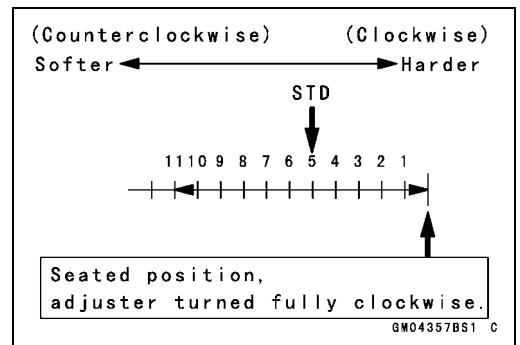
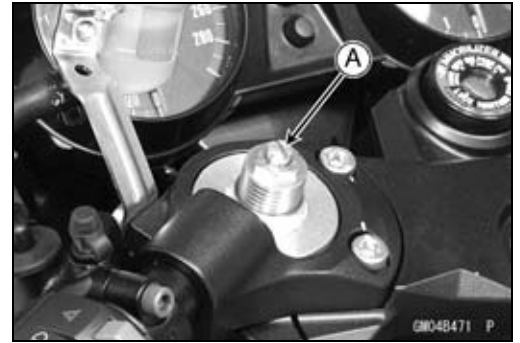

Compression Damping Force Adjustment

- To adjust the compression damping force, turn the compression damping adjuster [A] until you feel a click.
- The standard adjuster setting for the average-build rider of 68 kg (150 lb) with no passenger and no accessories is the **10th click** from the 1st click of the fully clockwise position.

⚠ WARNING

If both adjusters are not adjusted equally, handling may be impaired and a hazardous condition may result.

- The damping force can be left soft for average riding. But it should be adjusted harder for high speed riding or riding with a passenger. If the damping feels too soft or too stiff, adjust it in accordance with the following table.

Compression Damping Force Adjustment

Adjuster Position	Damping Force	Setting	Load	Road	Speed
13	Weak	Soft	Light	Good	Low
↑	↑	↑	↑	↑	↑
↓	↓	↓	↓	↓	↓
0	Strong	Hard	Heavy	Bad	High

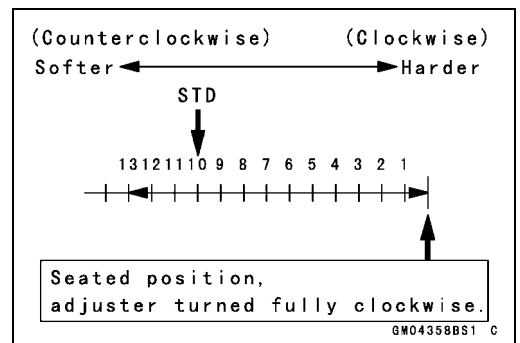

13-10 SUSPENSION

Front Fork

Spring Preload Adjustment

- Turn the spring preload adjuster [A] to change spring preload setting.
- The standard adjuster setting for the average-build rider of 68 kg (150 lb) with no passenger and no accessories is the 15 mm (0.59 in.) [B] from top as shown in the figure.

Adjuster Protrusion (from top)

- Standard: 15 mm (0.59 in.)
- Usable Range: 4 ~ 19 mm (0.16 ~ 0.75 in.)

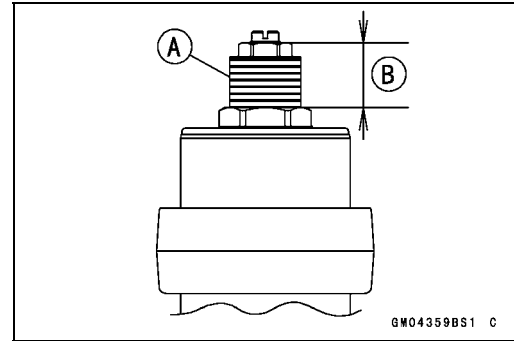

⚠ WARNING

If both adjusters are not adjusted equally, handling may be impaired and a hazardous condition may result.

- The spring preload can be left soft for average riding. But it should be adjusted harder for high speed riding or riding with a passenger. If the spring action feels too soft or too stiff, adjust it in accordance with the following table.

Spring Action

Adjuster Position	Damping Force	Setting	Load	Road	Speed
19 mm	Weak	Soft	Light	Good	Low
↑	↑	↑	↑	↑	↑
↓	↓	↓	↓	↓	↓
4 mm	Strong	Hard	Heavy	Bad	High

Front Fork Removal (Each Fork Leg)

- Remove:
 - Middle Fairings (see Middle Fairing Removal in the Frame chapter)
 - Inner Covers (see Inner Cover Removal in the Frame chapter)
 - Front Wheel (see Front Wheel Removal in the Wheels/Tires chapter)
 - Front Fender (see Front Fender Removal in the Frame chapter)
- ★ Loosen the upper fork clamp bolt [A] and fork top plug [B] beforehand if the fork leg is to be disassembled.

NOTE

○ Loosen the top plug after loosening the upper fork clamp bolt.

- Loosen the upper fork clamp bolt and lower fork clamp bolts [C].
- With a twisting motion, work the fork leg down and out.

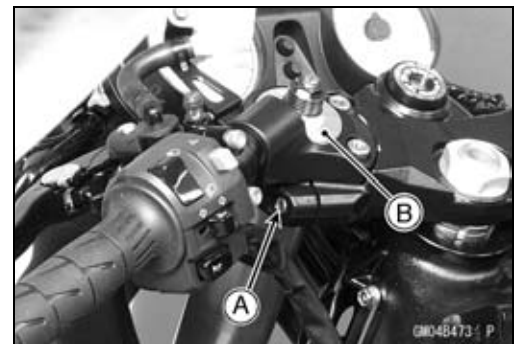

Front Fork

Front Fork Installation

- Install the fork so that the top end [A] of the outer tube as shown in the figure.
21.5 mm (0.85 in.) [B]
- Tighten the lower fork clamp bolts and fork top plug.
Torque - Front Fork Clamp Bolts (Lower): 30 N·m (3.1 kgf·m, 22 ft·lb)
Front Fork Top Plug: 22 N·m (2.2 kgf·m, 16 ft·lb)
- Tighten the upper fork clamp bolt.
Torque - Front Fork Clamp Bolt (Upper): 20 N·m (2.0 kgf·m, 15 ft·lb)

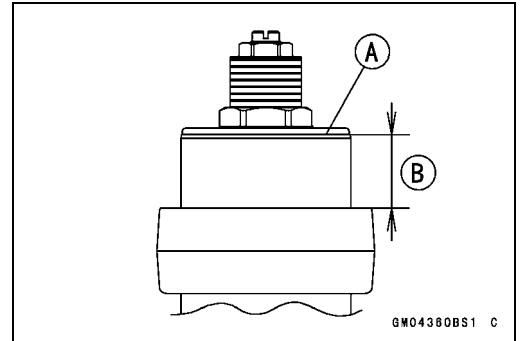

NOTE

- Tighten the two clamp bolts alternately two times to ensure even tightening torque.
- Tighten the top plug before tightening the upper fork clamp bolt.
- Install the removed parts (see appropriate chapters).
- Adjust the spring preload and the damping force.

Front Fork Oil Change

- Remove the front fork (see Front Fork Removal).
- Hold the inner tube lower end in a vise.
- Unscrew the top plug [A] out of the outer tube.



- Install the clamps [A] as shown in the figure.

NOTE

○ Set the clamps so that the cutout [B] of the upper side does not touch the tongue shape of stopper, pull up the outer tube [C] to hold it by the clamps, and then tighten the two bolts [D]. The outer tube is used as a guide.

Special Tools - Fork Spring Compressor: 57001-1540
Fork Spring Compressor: 57001-1587

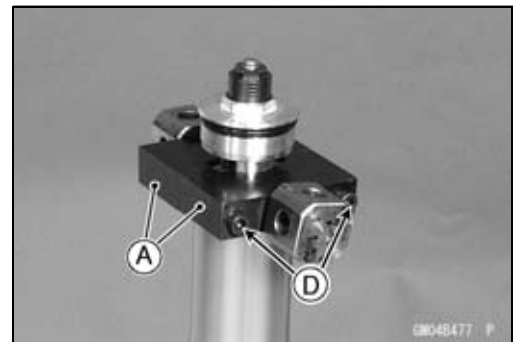

13-12 SUSPENSION

Front Fork

- Insert the holder bar [A] into the axle hole of the front fork [B].

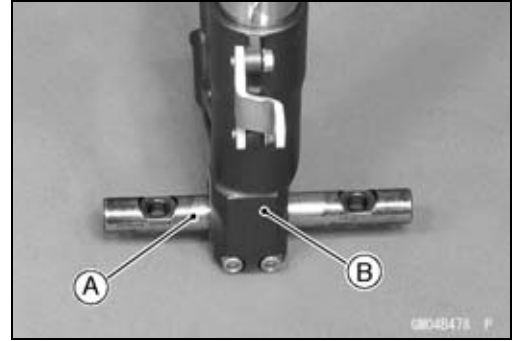

- Insert the compression shaft and install the nut.
- Insert the lower end of the compression shaft [A] into the hole [B] of the holder bar.



- Screw the adjust nut [A] onto the compression shaft as shown in the figure.
- Screw the locknut [B].
About 20 mm (0.79 in.) [C]
- Set the other side compression shaft same process.

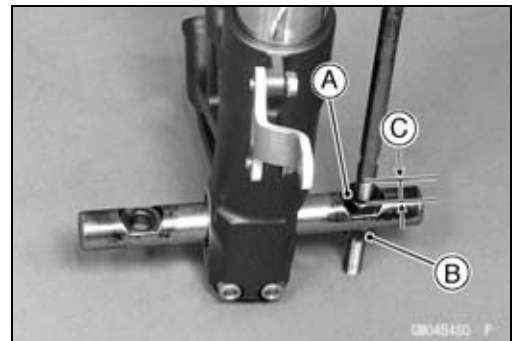

- Set the holder bar [A] and compression shafts [B].

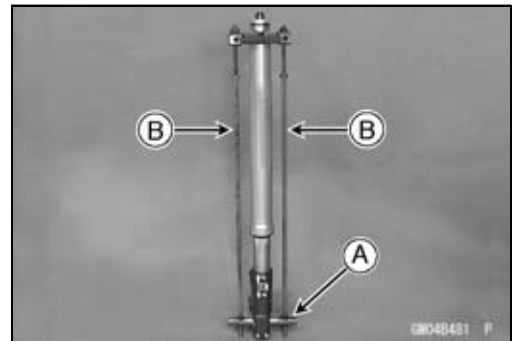

- Screw in nuts [A] come out the piston rod nut.

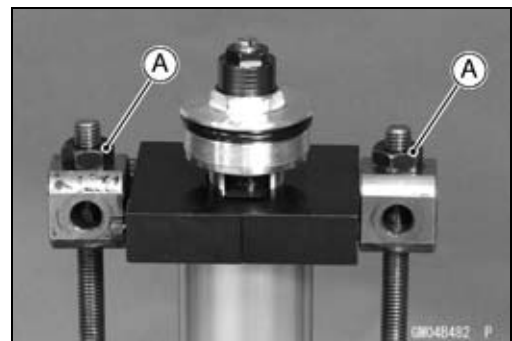

Front Fork

- Holding the piston rod nut with a wrench [A], remove the top plug [B] from the piston rod.

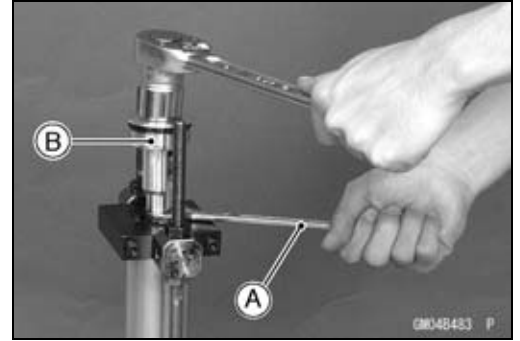

- Remove:
 Washer [A]
 Collar [B]
 Rebound Damping Adjuster Rod [C]
 Fork Spring [D]

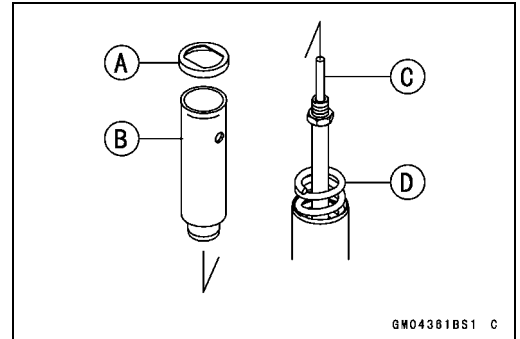

- Drain the fork oil into a suitable container.
- Pump the piston rod [A] up and down at least ten times to expel the oil from the fork.

**Special Tool - Fork Piston Rod Puller, M12 × 1.25 [B]:
57001-1289**

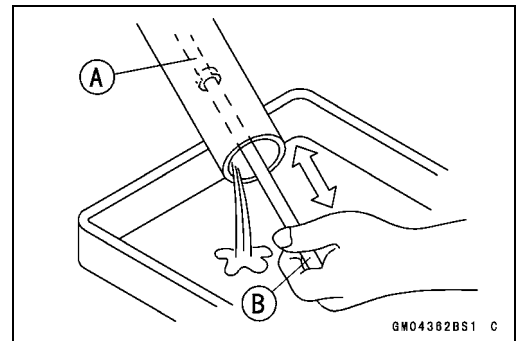

- Hold the fork tube upright, press the inner tube [A] and the piston rod all the way down.
- Pour in the type and amount of fork oil specified.

Fork Oil
 Viscosity: **KAYABA 01 (KHL15-10) or equivalent SAE 5W**

Amount (per side):
 When changing oil: **Approx. 480 mL (16.2 US oz.)**
 After disassembly and completely dry:
563 ±4 mL (19.0 ±0.14 US oz.)

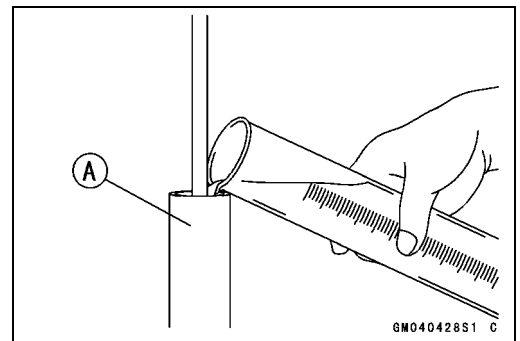

13-14 SUSPENSION

Front Fork

- ★ If necessary, measure the oil level as follows.
- Hold the inner tube vertically in a vise.
- Pump the inner tube several times to expel air bubbles.
- Using the piston rod puller [A], move the piston rod [B] up and down more than ten times in order to expel all the air from the fork oil.

Special Tool - Fork Piston Rod Puller, M12 × 1.25: 57001-1289

- Remove the piston rod puller.
- Wait until the oil level settles.
- With the fork fully compressed and the piston rod fully pushed in, insert a tape measure or rod into the inner tube, and measure the distance from the top of the inner tube to the oil.

Oil Level (fully compressed, without spring)

Standard: 88 ±2 mm (3.46 ±0.08 in.)

(from the top of the inner tube)

NOTE

- Fork oil level may also be measured using the fork oil level gauge.

Special Tool - Fork Oil Level Gauge [A]: 57001-1290

- With the fork fully compressed and without fork spring, insert the gauge tube into the inner tube [B] and position the stopper across the top end [C] of the inner tube.
- Set the gauge stopper [D] so that its lower side shows the oil level distance specified [E].
- Pull the handle slowly to pump out the excess oil until the oil no longer comes out.
- ★ If no oil is pumped out, there is insufficient oil in the inner tube. Pour in enough oil, then pump out the excess oil as shown above.

- Screw the fork piston rod puller onto the end of the piston rod.

Special Tool - Fork Piston Rod Puller, M12 × 1.25: 57001-1289

- Pull the puller up above the outer tube top.
- Install the fork spring [A] with the smaller end facing [B] upward.
- Install:
 - Collar
 - Washer

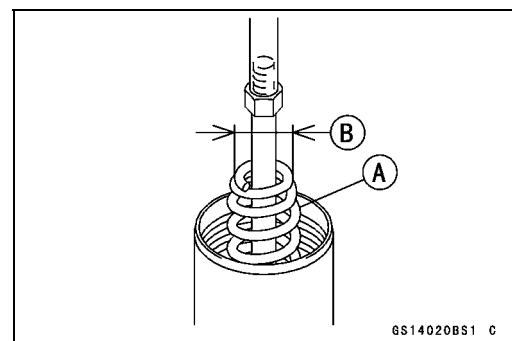
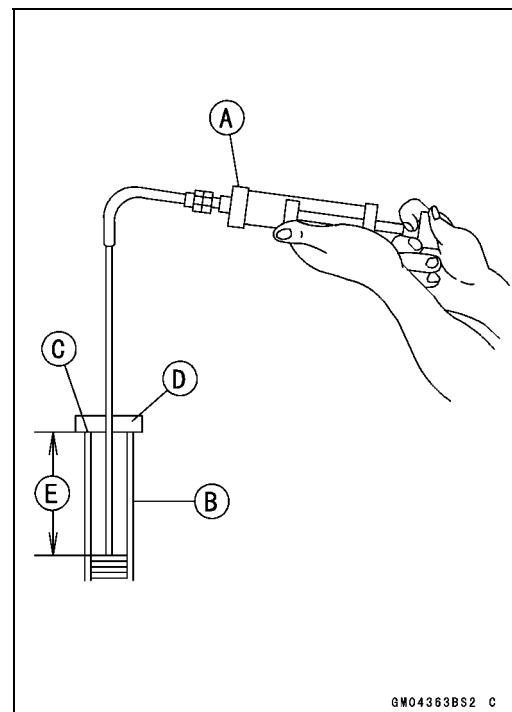
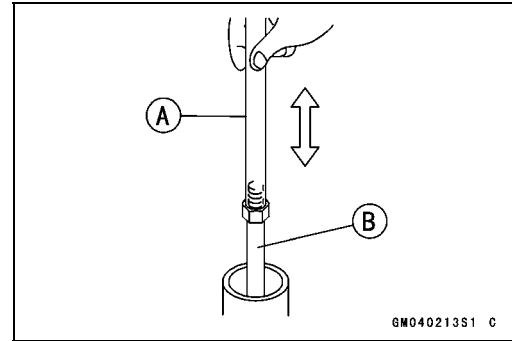

Front Fork

- Screw the rod nut [A] onto the piston rod [B] as shown in the figure.
11 mm (0.43 in.) [C]

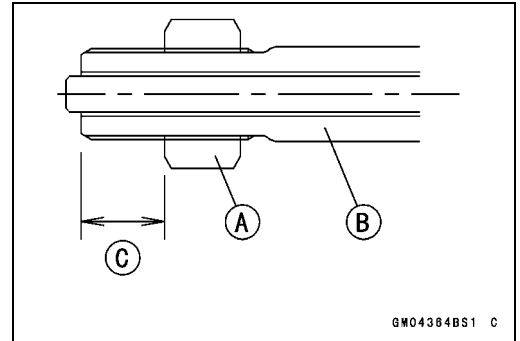

- Check the distance between the bottom end [A] of the top plug and rebound damping adjuster [B] with a pair of vernier caliper.
13 mm (0.51 in.) [C]

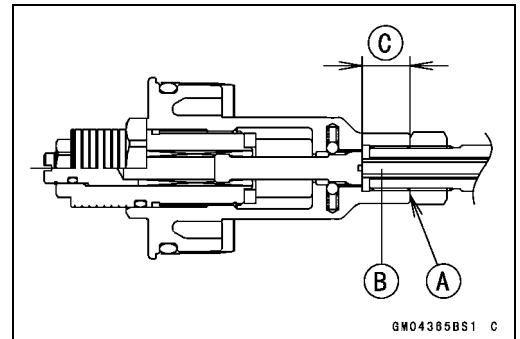

- Set the fork spring compressor on the washer using the outer tube as a guide.
Special Tools - Fork Spring Compressor: 57001-1540
Fork Spring Compressor: 57001-1587

NOTE

○Set the clamps so that the cutout of the upper side does not fit the hole of washer, pull up the outer tube to hold it by the clamps, and then tighten the two bolts. The outer tube is used as a guide.

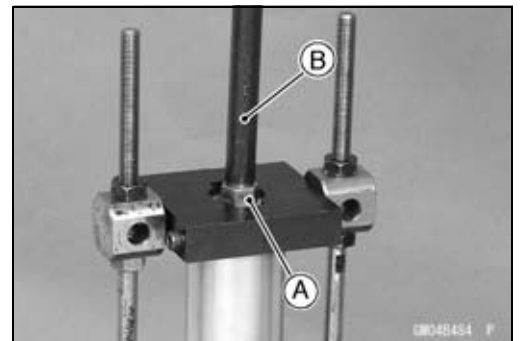

- Hold the piston rod nut [A].
- Remove the piston rod puller [B].
- Install the rebound damping adjuster rod.
- Screw in the top plug [A] stopped onto the piston rod.
- Check the O-ring [B] on the top plug and replace it with a new one if damaged.
- Holding the top plug with a wrench, tighten the piston rod nut [C] against the top plug.
Torque - Piston Rod Nut: 28 N·m (2.9 kgf·m, 21 ft·lb)
- While holding up the washer with the clamps, loosen the fork spring compressor nuts.
- Remove the fork spring compressor.

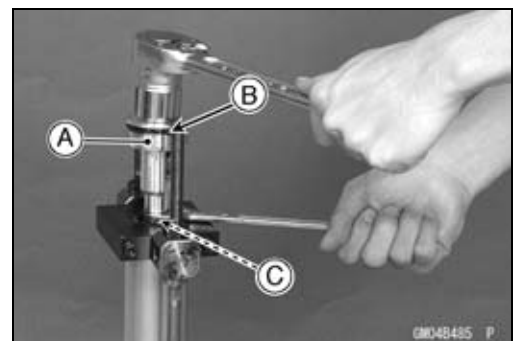

13-16 SUSPENSION

Front Fork

- Raise the outer tube and screw the top plug into it and install it to the steering stem.
- Screw in the spring preload adjuster [A] of the top plug so that the distance between the adjuster top and the top plug surface is 15 mm (0.59 in.) [B].
- Turn in the rebound damping adjuster until the fully tightened position and turn backward the 5th click.
- Install the front fork (see Front Fork Installation).

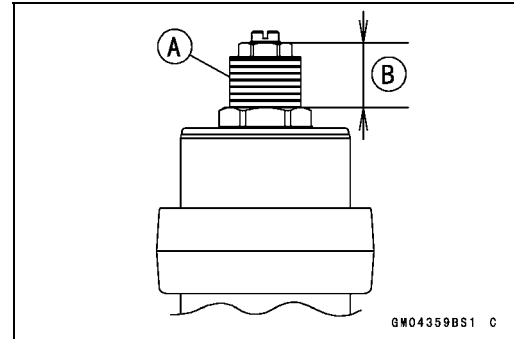

Front Fork Disassembly

- Remove the front fork (see Front Fork Removal).
- Drain the fork oil (see Front Fork Oil Change).
- Hold the front fork in a vise [A].
- Stop the cylinder [B] from turning by using the fork cylinder holder [C].

Special Tool - Fork Cylinder Holder: 57001-1287

- Unscrew the Allen bolt [D], then take the bolt and gasket out of the bottom of the inner tube.

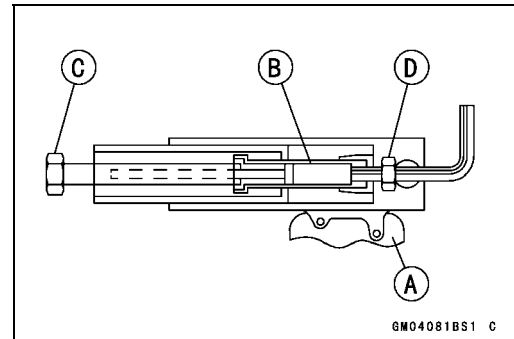

- Take the cylinder unit [A].
- Do not disassemble the cylinder unit.

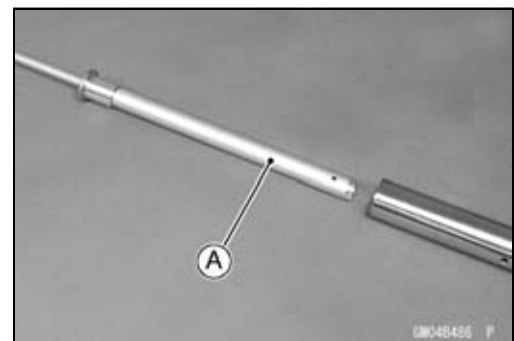

- Separate the outer tube from the inner tube.
- Pull out the dust seal.
- Remove the retaining ring [A] from the outer tube.
- Remove the oil seal [B] and washer [C].

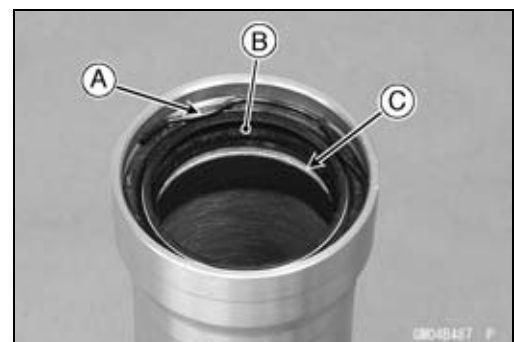

Front Fork Assembly

- Replace the following parts with a new one.
 - Oil Seal
 - Bottom Allen Bolt Gasket
- Insert the cylinder unit [A] into the inner tube [B].
- Stop the cylinder from turning by using the fork cylinder holder.

Special Tool - Fork Cylinder Holder: 57001-1287

- Apply a non-permanent locking agent to the thread of the Allen bolt, and tighten it.

Torque - Front Fork Bottom Allen Bolt: 23 N·m (2.3 kgf·m, 17 ft·lb)

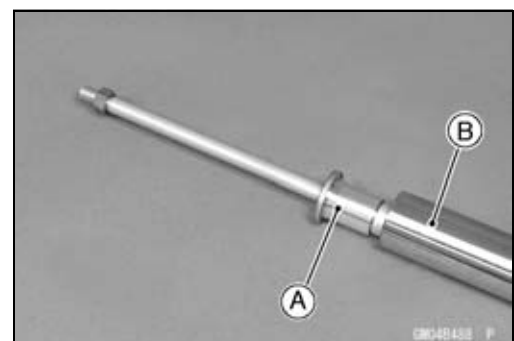

Front Fork

- Install the following parts into the inner tube [A].
 - Dust Seal [B]
 - Retaining Ring [C]
 - Oil Seal [D]
 - Washer [E]

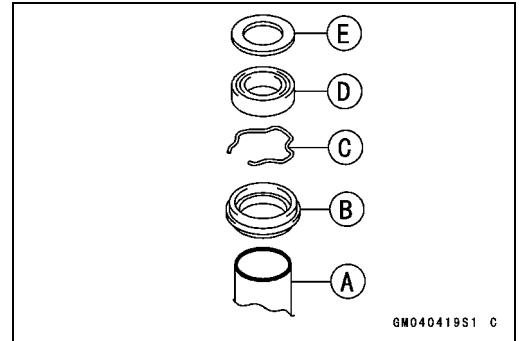

- Insert the inner tube to the outer tube.
- After installing the washer, install the oil seal [A] by using the fork oil seal driver [B].

Special Tool - Fork Oil Seal Driver, ϕ 43: 57001-1530

- Install the retaining ring and dust seal into the outer tube.
- Pour in the specified type of oil (see Front Fork Oil Change).

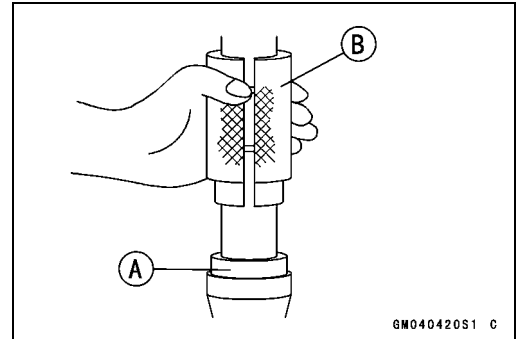

Inner Tube Inspection

- Visually inspect the inner tube [A], and repair any damage.
- Nicks or rust damage can sometimes be repaired by using a wet-stone to remove sharp edges or raised areas which cause seal damage.
- ★ If the damage is not repairable, replace the inner tube. Since damage to the inner tube damages the oil seal, replace the oil seal whenever the inner tube is repaired or replaced.

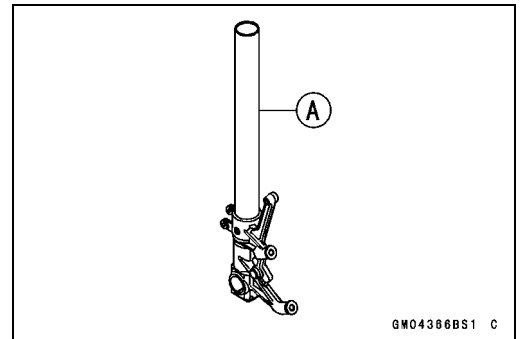

CAUTION

If the inner tube is badly bent or creased, replace it. Excessive bending, followed by subsequent straightening, can weaken the inner tube.

- Temporarily assemble the inner and outer tubes, and pump them back and forth manually to check for smooth operation.
- If you feel binding or catching, the inner and outer tubes must be replaced.

⚠ WARNING

A straightened inner or outer fork tube may fall in use, possibly causing an accident. Replace a badly bent or damaged inner or outer tube and inspect the other tube carefully before reusing it.

13-18 SUSPENSION

Front Fork

Dust Seal Inspection

- Inspect the dust seal [A] for any signs of deterioration or damage.
- ★ Replace it if necessary.

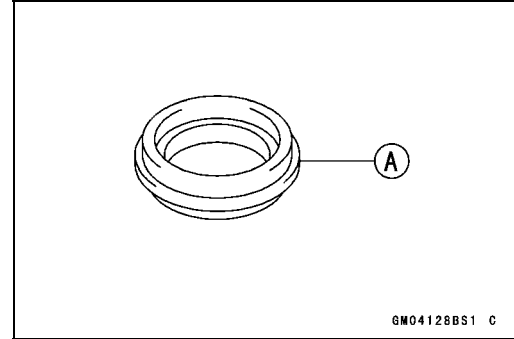

Spring Tension

- Since a spring becomes shorter as it weakens, check its free length [A] to determine its condition.
- ★ If the spring of either fork leg is shorter than the service limit, it must be replaced. If the length of a replacement spring and that of the remaining spring vary greatly, the remaining spring should also be replaced in order to keep the fork legs balanced for motorcycle stability.

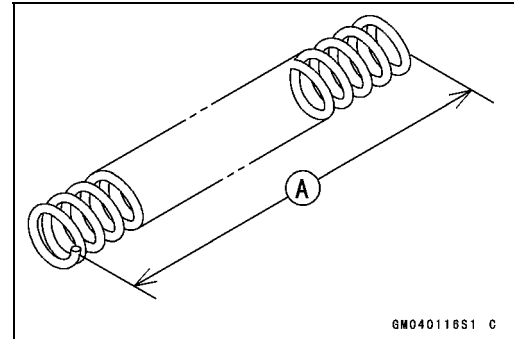

Spring Free Length

Standard: 257 mm (10.12 in.)

Service Limit: 252 mm (9.92 in.)

Rear Shock Absorber

Rebound Damping Force Adjustment

- To adjust the rebound damping force, turn the lower damping adjuster [A] to the desired position, until you feel a click.
- The standard adjuster setting for an average-build rider of 68 kg (150 lb) with no passenger and no accessories is the **1 2/4 turns out** from the fully clockwise position.

Rebound Damping Force Adjustment

Adjuster Position	Damping Force	Setting	Load	Road	Speed
2 2/4 Turns Out	Weak	Soft	Light	Good	Low
↑	↑	↑	↑	↑	↑
↓	↓	↓	↓	↓	↓
0	Strong	Hard	Heavy	Bad	High

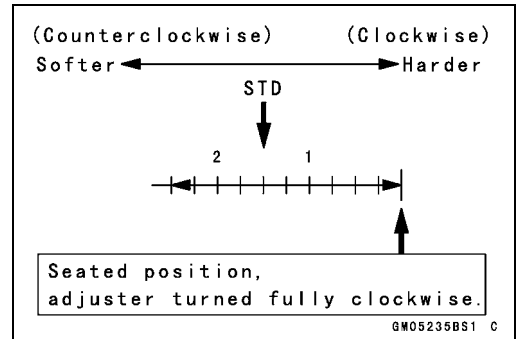
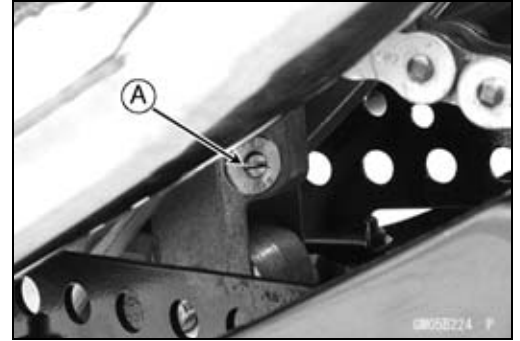

Compression Damping Force Adjustment

- To adjust the compression damping force, turn the upper damping adjuster [A] to the desired position until you feel a click.
- The standard adjuster setting for the average-build rider of 68 kg (150 lb) with no passenger and no accessories is the **2 1/4 turns out** from the fully clockwise position.

Rebound Damping Force Adjustment

Adjuster Position	Damping Force	Setting	Load	Road	Speed
4 Turns Out	Weak	Soft	Light	Good	Low
↑	↑	↑	↑	↑	↑
↓	↓	↓	↓	↓	↓
0	Strong	Hard	Heavy	Bad	High

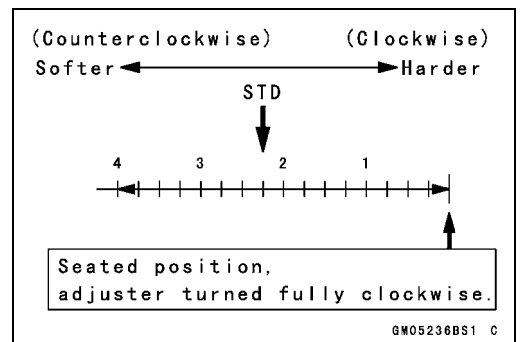

Spring Preload Adjustment

- Remove the rear shock absorber from the frame (see Rear Shock Absorber Removal).
- Loosen the locknut and turn out the adjusting nut to free the spring.

Special Tool - Hook Wrench T=3.2 R37: 57001-1522

13-20 SUSPENSION

Rear Shock Absorber

- To adjust the spring preload, turn in the adjusting nut [A] to the desired position and tighten the locknut [B].
Spring Length [C]

Spring Preload Setting

Standard: Spring length 175.5 mm (6.9 in.)
Usable Range: Spring length 175.5 ~ 191.5 mm (6.909 ~ 7.539 in.)

- The standard adjusting nut setting for an average-build rider of 68 kg (150 lb) with no passenger and no accessories is 175.5 mm (6.9 in.) spring length.

- Remove the chain cover [A] (see Drive Chain Removal in the Final Drive chapter).
- Remove the bolts [B] and left foot guard [C] for turning the hook wrench easily.

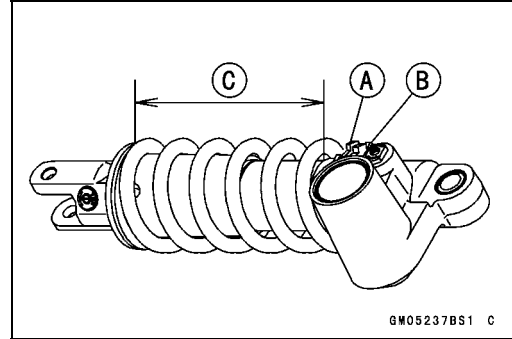

- To adjust the spring preload, turn in the adjusting nut to the desired position and tighten the locknut by using hook wrenches [A] with the rear shock absorber attached the frame.

Special Tool - Hook Wrench T=3.2 R37: 57001-1522

★ If the spring action feels too soft or too stiff, adjust it.

Spring Adjustment

Adjuster Position	Damping Force	Setting	Load	Road	Speed
191.5 mm (7.539 in.)	Weak	Soft	Light	Good	Low
↑	↑	↑	↑	↑	↑
↓	↓	↓	↓	↓	↓
175.5 mm (6.909 in.)	Strong	Hard	Heavy	Bad	High

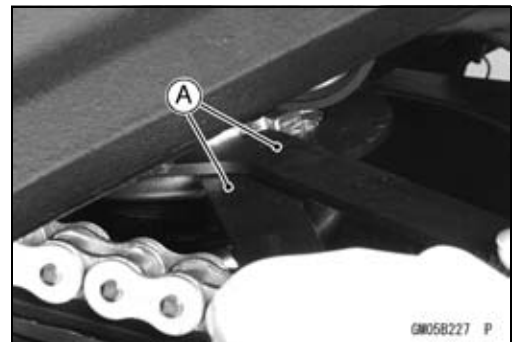
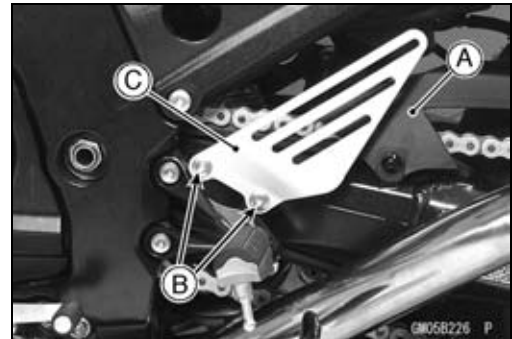

Rear Shock Absorber Removal

- Remove:
 - Rear Fairing (see Rear Fairing Removal in the Frame chapter)
 - Bolts [A] (Both Sides)
 - Bracket [B]
 - Lower Fairings (see Lower Fairings Removal in the Frame chapter).
- Raise the rear wheel off the ground with the jack.

Special Tools - Jack: 57001-1238

Jack Attachment: 57001-1608

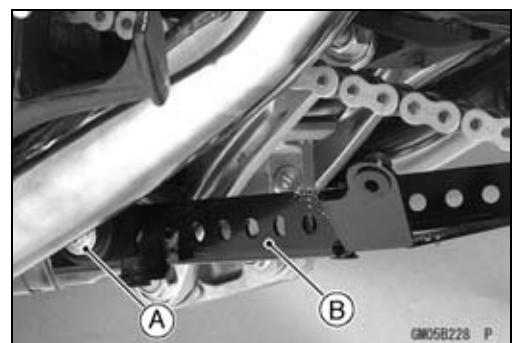

Rear Shock Absorber

- Squeeze the brake lever slowly and it with a band [A].

⚠ WARNING

Be sure to hold the front brake when removing the shock absorber, or the motorcycle may fall over. It could cause an accident and injury.

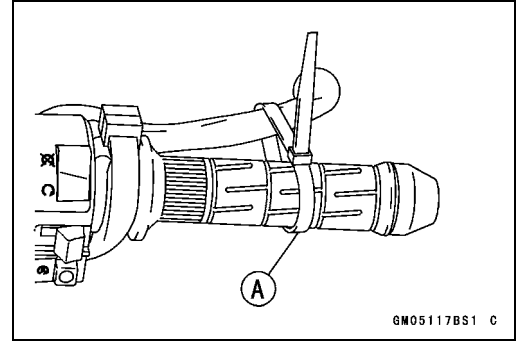

- Remove:
Lower Shock Absorber Nut and Bolt [A]
Upper Tie-Rod Nut and Bolt [B]

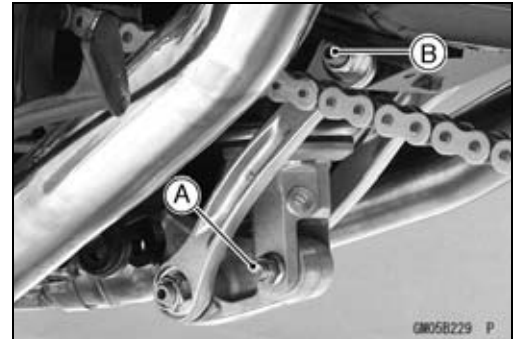

- Remove the upper shock absorber nut and bolt [A]
- Remove the shock absorber downward.



Rear Shock Absorber Installation

- Tighten:
Torque - Rear Shock Absorber Nuts: 34 N·m (3.5 kgf·m, 25 ft·lb)
Tie-Rod Nuts: 59 N·m (6.0 kgf·m, 44 ft·lb)

Rear Shock Absorber Inspection

- Remove the rear shock absorber (see Rear Shock Absorber Removal).
- Visually inspect the following items.
Smooth Stroke
Oil Leakage
Crack or Dent
- ★ If there is any damage to the rear shock absorber, replace it.
- Visually inspect the rubber bushing.
- ★ If it show any signs of damage, replace it.

13-22 SUSPENSION

Rear Shock Absorber

Rear Shock Absorber Scrapping

⚠ WARNING

Since the reservoir tank of the rear shock absorber contains nitrogen gas, do not incinerate the reservoir tank without first releasing the gas or it may explode.

- Remove the rear shock absorber (see Rear Shock Absorber Removal).
- Drill the hole [A] of the reservoir tank using about 2 mm (0.08 in.) drillbit.

⚠ WARNING

Since the high pressure gas is dangerous, do not point the drill toward your face or body.

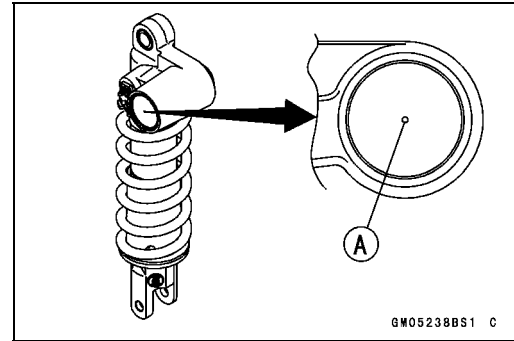

Swingarm

Swingarm Removal

- Remove:
 - Chain Cover (see Drive Chain Removal in the Final Drive chapter)
 - Rear Wheel (see Rear Wheel Removal in the Wheels/Tires chapter)
 - Bolts [A]
 - Brackets [B]

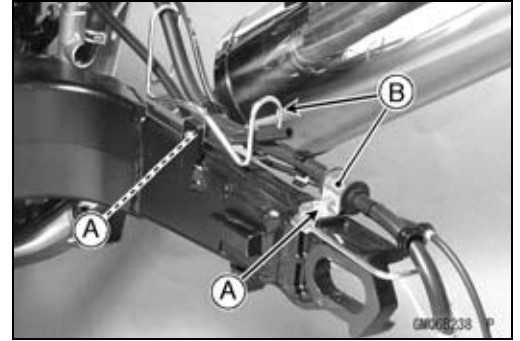

- Remove:
 - Upper Tie-Rod Nut and Bolt [A]
 - Rear Shock Absorber [B] (see Rear Shock Absorber Removal)

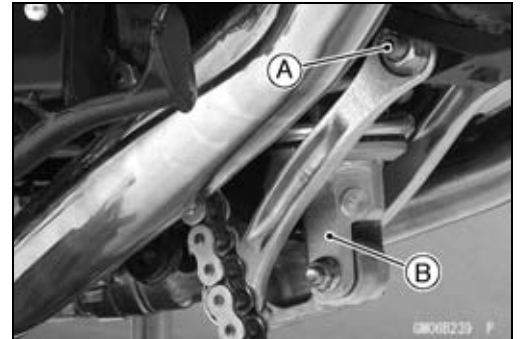

- Unscrew the swingarm pivot shaft locknut [A].

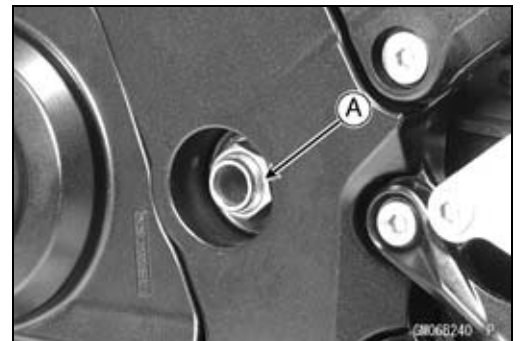

- Unscrew the swingarm pivot collar locknut [A] using the nut wrench [B].

Special Tool - Swingarm Pivot Nut Wrench: 57001-1597

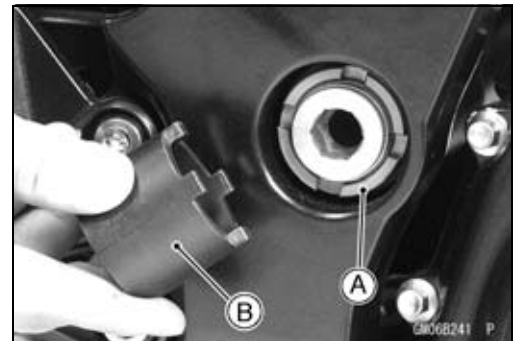

- Unscrew the swingarm pivot shaft [A] few times.
- Turn out the swingarm pivot adjusting collar [B].
- Pull out the pivot shaft right side of the motorcycle and remove the swingarm.

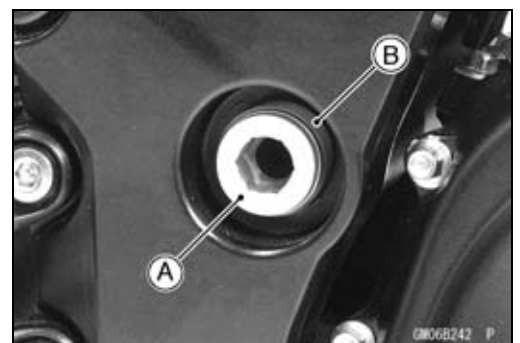

13-24 SUSPENSION

Swingarm

Swingarm Installation

- Apply plenty of grease to the lip of the oil seals [A].
- Install the collar.



- Place the adjusting collar [A] the frame [B] as shown in the figure.
11 mm (0.43 in.) [C]

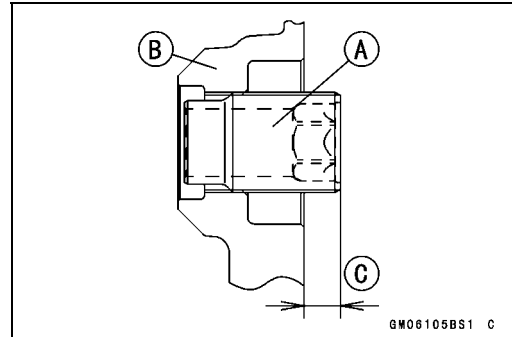

- Insert the pivot shaft [A] into the frame from the right side.
- Tighten the pivot shaft so that the clearance between the adjusting collar [B] and the ball bearing [C] come to 0 mm (0 in.).

Torque - Swingarm Pivot Adjusting Collar: 20 N·m (2.0 kgf·m, 15 ft·lb)

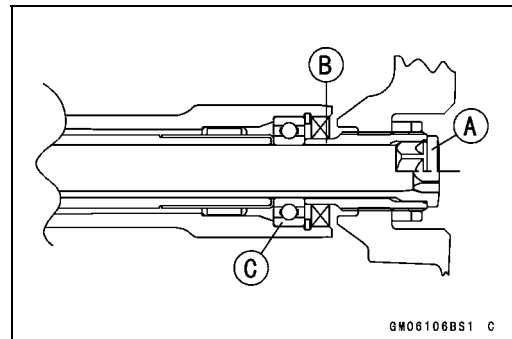

- Tighten the adjusting collar locknut [A] with the swingarm pivot nut wrench [B].

Special Tool - Swingarm Pivot Nut Wrench: 57001-1597

Torque - Swingarm Pivot Adjusting Collar Locknut: 98 N·m (10.0 kgf·m, 72 ft·lb)

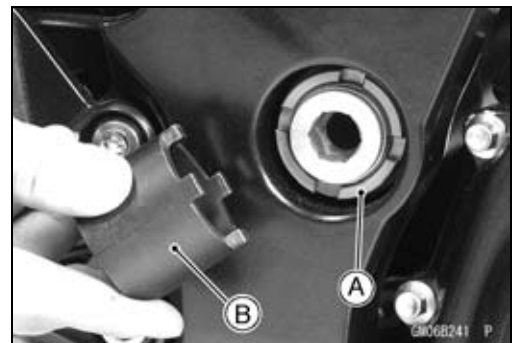

- Tighten the pivot shaft nut [A].
Torque - Swingarm Pivot Shaft Nut: 108 N·m (11.0 kgf·m, 80 ft·lb)
- Install the removed parts (see appropriate chapters).

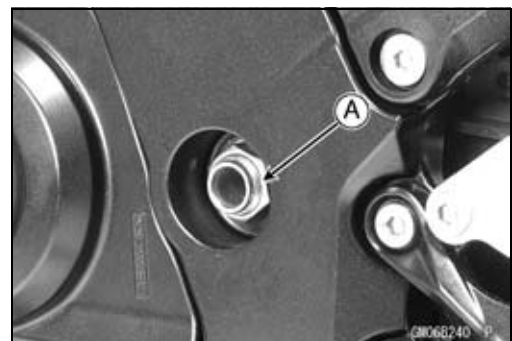

Swingarm

Swingarm Bearing Removal

- Remove:
 - Swingarm (see Swingarm Removal)
 - Collar [A]
 - Oil Seals [B]
 - Sleeve [C]
 - Circlip [D] (Right Side)

Special Tool - Inside Circlip Pliers: 57001-143

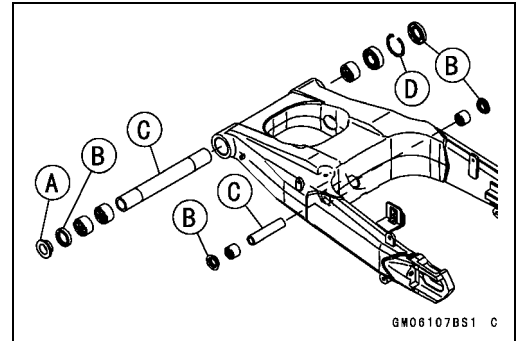

- Remove the ball bearing and needle bearings.

Special Tool - Oil Seal & Bearing Remover [A]: 57001-1058

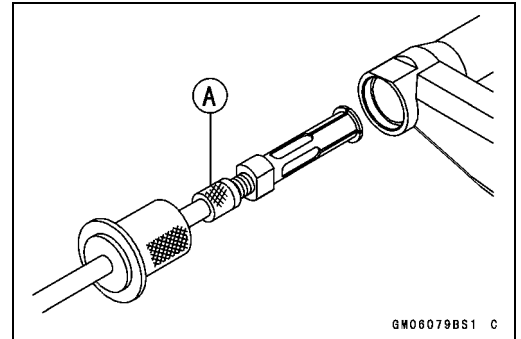

Swingarm Bearing Installation

- Replace the ball and needle bearings [A] with new ones.
- Install the ball and needle bearings so that the manufacturer's marks face out.

Special Tools - Bearing Driver Set: 57001-1129
Needle Bearing Driver, $\phi 28$ [B]: 57001-1610
Spacer $\phi 28$: 57001-1663

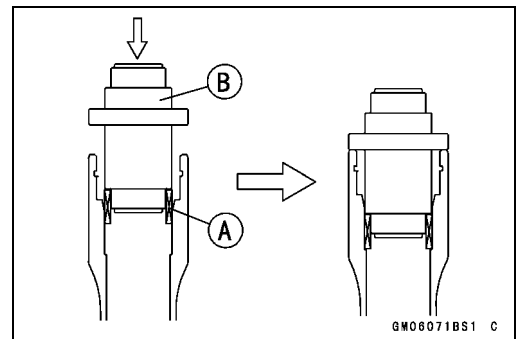

13-26 SUSPENSION

Swingarm

- Install the needle bearings [A], ball bearing [B] and oil seals [C] position as shown in the figure.

Circlip [D]

32 mm (1.26 in.) [E]

17 mm (0.67 in.) [F]

27.5 mm (1.08 in.) [G]

9.5 mm (0.37 in.) [H]

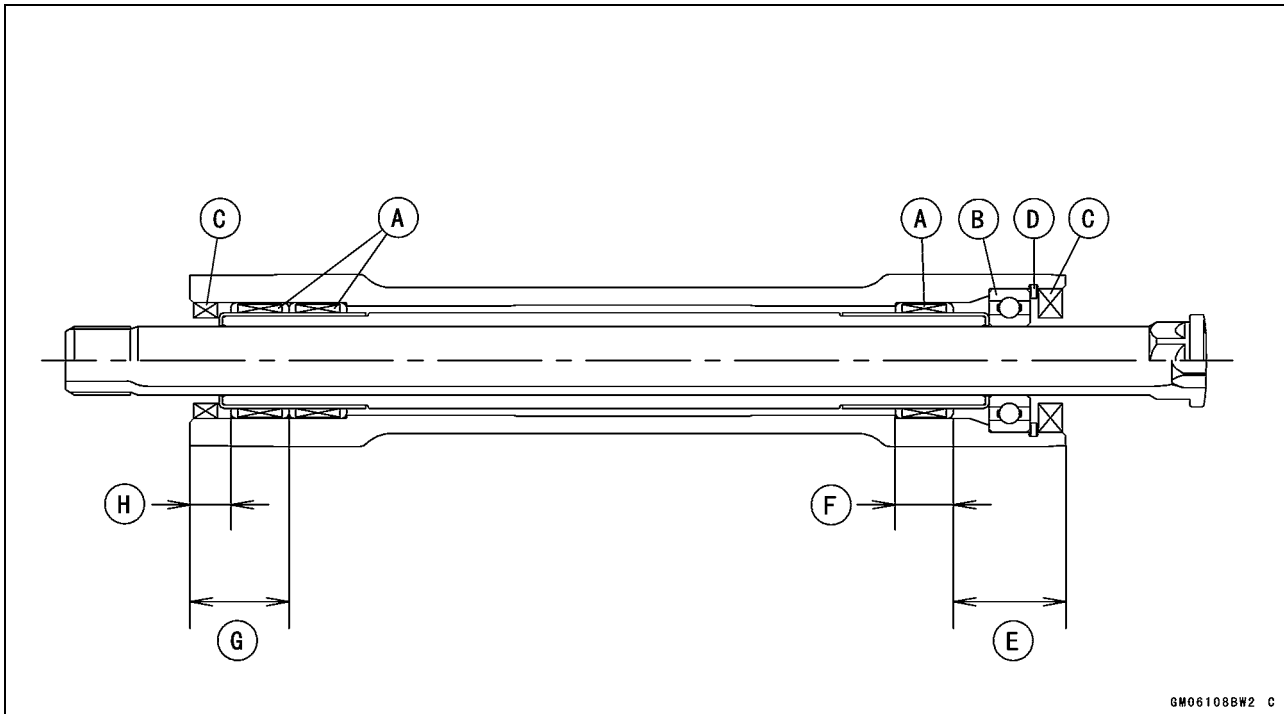

Swingarm Bearing, Sleeve Inspection

CAUTION

Do not remove the bearings for inspection. Removal may damage them.

- Inspect the needle bearings [A] and ball bearing installed in the swingarm.
- The rollers and ball in a bearing normally wear very little, and wear is difficult to measure. Instead of measuring, visually inspect the bearing for abrasion, discoloration, or other damage.
- ★ If the needle bearing and sleeve [B] show any signs of abnormal wear, discoloration, or damage, replace them as a set.

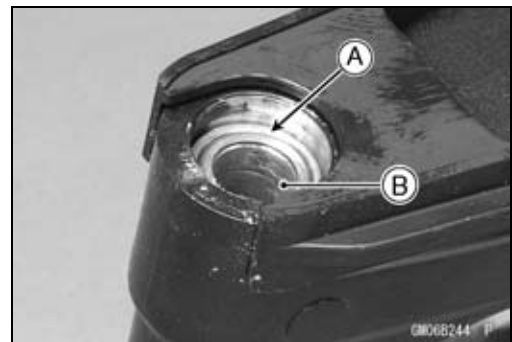

Swingarm

- Turn the bearing in the swingarm back and forth [A] while checking for plays, roughness, or binding.
- ★ If bearing play, roughness, or binding is found, replace the bearing.
- Examine the bearing seal [B] for tears or leakage.
- ★ If the seal is torn or is leaking, replace the bearing.



Chain Guide Inspection

- Refer to the Chain Guide Wear Inspection in the Periodic Maintenance chapter.

13-28 SUSPENSION

Tie-Rod, Rocker Arm

Tie-Rod Removal

- Squeeze the brake lever slowly and hold it with a band [A].

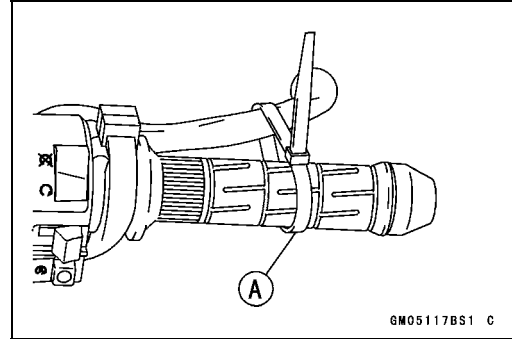

- Remove:
 - Lower Fairings (see Lower Fairing Removal in the Frame chapter)
 - Rear Fairing (see Rear Fairing Removal in the Frame chapter)
 - Bracket (see Rear Shock Absorber Removal)
- Raise the rear wheel off the ground with the jack.

Special Tools - Jack: 57001-1238

Jack Attachment: 57001-1608

- Remove:
 - Upper Tie-Rod Nut and Bolt [A]
 - Lower Tie-Rod Nut and Bolt [B]
 - Tie-Rods [C]

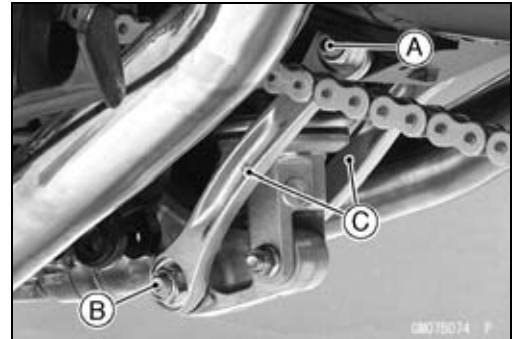

Tie-Rod Installation

- Apply grease to the inside of the grease seals.
- Install each tie-rod so that the arrow faces [A] forward.
- Tighten:

Torque - Tie-Rod Nuts: 59 N·m (6.0 kgf·m, 44 ft·lb)

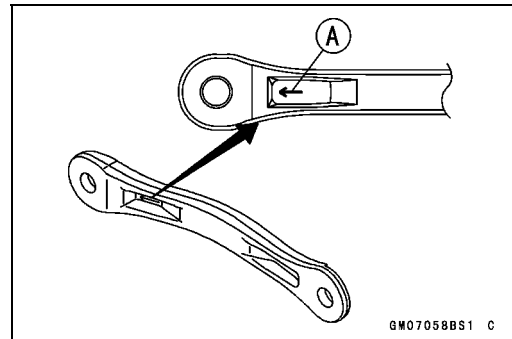

Rocker Arm Removal

- Squeeze the brake lever slowly and hold it with a band.
- Remove:
 - Lower Fairings (see Lower Fairing Removal in the Frame chapter)
 - Rear Fairing (see Rear Fairing Removal in the Frame chapter)
 - Bracket (see Rear Shock Absorber Removal)
 - Muffler Bodies (see Muffler Body Removal in the Engine Top End chapter)
- Raise the rear wheel off the ground with the jack.

Special Tools - Jack: 57001-1238

Jack Attachment: 57001-1608

- Remove:
 - Lower Rear Shock Absorber Nut and Bolt [A]
 - Lower Tie-Rod Nut and Bolt [B]
 - Rocker Arm Nut and Bolt [C]
 - Rocker Arm [D]

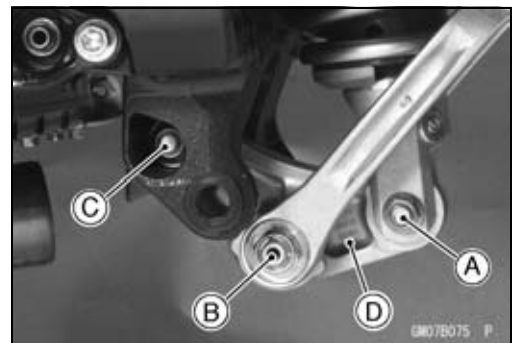

Tie-Rod, Rocker Arm

Rocker Arm Installation

- Apply grease to the inside of the grease seals.
- Tighten:
 - Torque - Uni-Trak Rocker Arm Nut: 34 N·m (3.5 kgf·m, 25 ft·lb)
 - Tie-Rod Nuts: 59 N·m (6.0 kgf·m, 44 ft·lb)
 - Rear Shock Absorber Nut (Lower): 34 N·m (3.5 kgf·m, 25 ft·lb)

Tie-Rod and Rocker Arm Bearing Removal

- Remove:
 - Tie-Rods (see Tie-Rod Removal)
 - Rocker Arm (see Rocker Arm Removal)
 - Sleeves [A]
 - Oil Seals [B]
 - Swingarm [C] (see Swingarm Removal)
 - Remove the needle bearings [D], using the bearing remover head and bearing remover shaft.
- Special Tools - Bearing Remover Head, $\phi 20 \times \phi 22$: 57001-1293**
Bearing Remover Shaft, $\phi 13$: 57001-1377

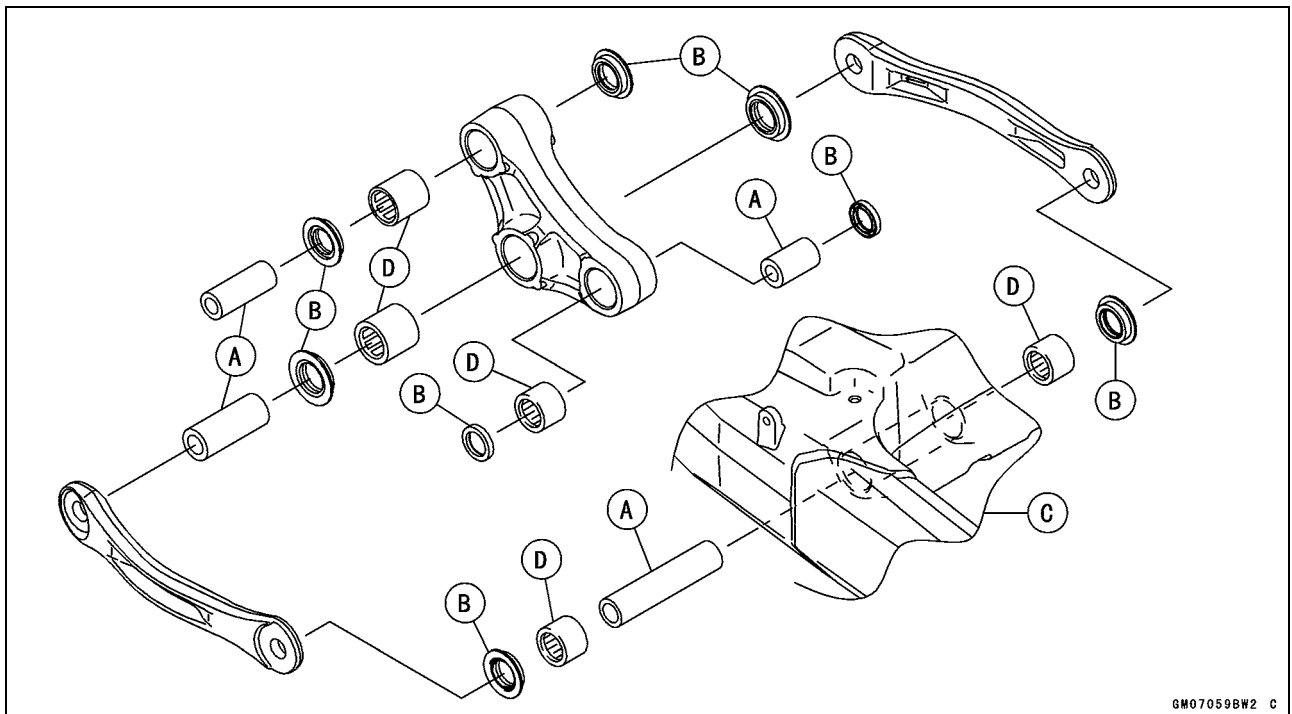

GM07059BW2 C

Tie-Rod and Rocker Arm Bearing Installation

- Replace the needle bearing and oil seals with new ones.
- Apply plenty of grease to the lips of the oil seals.
- Install the needle bearings and oil seals position as shown in the figure.

13-30 SUSPENSION

Tie-Rod, Rocker Arm

- Screw the needle bearing driver [A] into the driver holder [B].
- Insert the needle bearing driver into the needle bearing [C] and press the needle bearing into the housing until the driver contacts the end surface of the housing.
Bearing Pressing Depth: 5.5 mm (0.22 in.) [D]
5.0 mm (0.20 in.) [E]

NOTE

- For a bearing of inner diameter $\phi 18$, select the pressing side of the needle bearing driver according to its pressing depth.

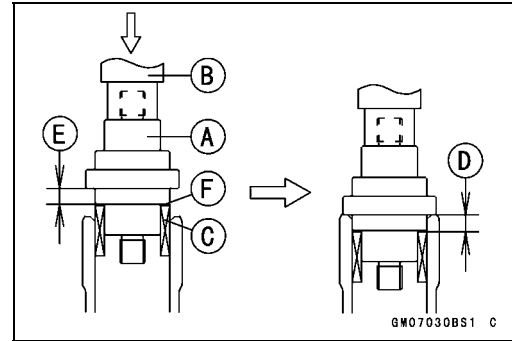

Special Tools - Bearing Driver Set: 57001-1129

Needle Bearing Driver, $\phi 17/\phi 18$: 57001-1609

Spacer, $\phi 18$ [F]: 57001-1636

Needle Bearing Driver, $\phi 20$ & Spacer, $\phi 28$: 57001-1678

NOTE

- Install the needle bearings so that the marked side faces in.

Needle Bearing [A]

Oil Seals [B]

Front [C]

Right Side [D]

Left Side [E]

Rear Shock Absorber [F]

Tie-Rods [G]

Rocker Arm [H]

7.5 mm (0.30 in.) [I]

10 mm (0.39 in.) [J]

5.5 mm (0.22 in.) [K]

5.0 mm (0.20 in.) [L]

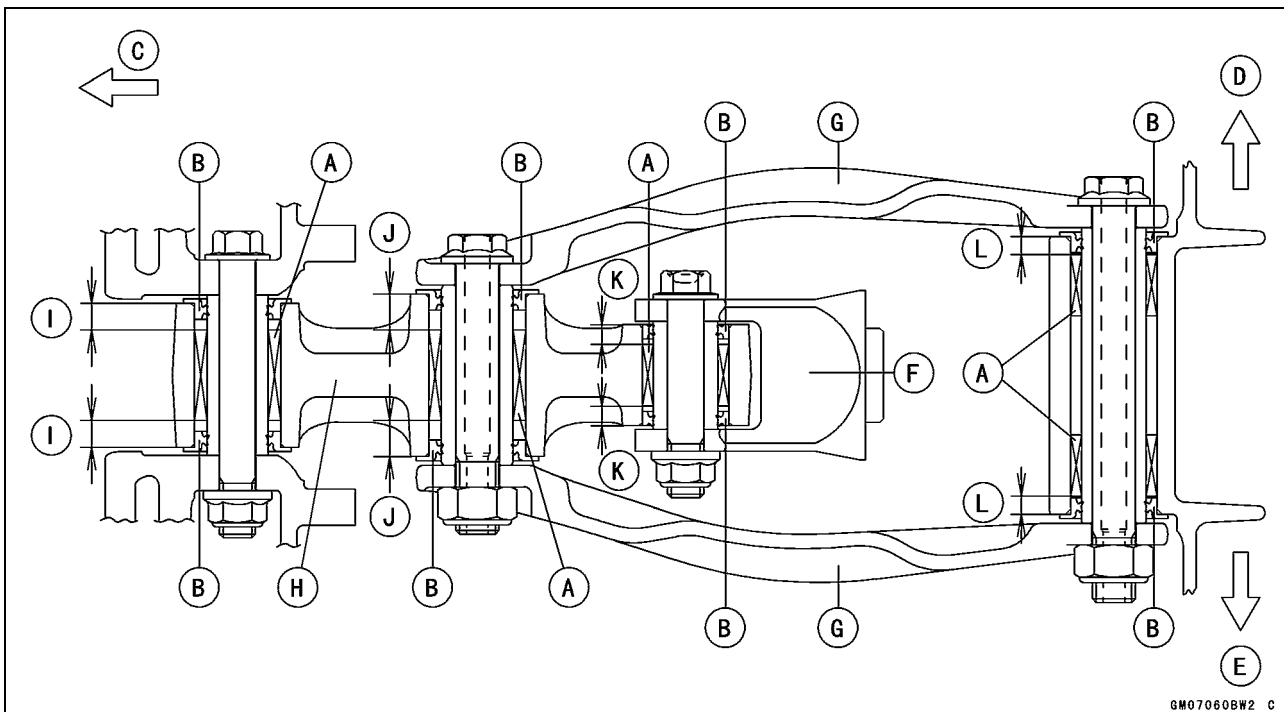

Tie-Rod, Rocker Arm**Rocker Arm/Tie-Rod Bearing, Sleeve Inspection****CAUTION**

Do not remove the bearings for inspection. Removal may damage them.

- Visually inspect the locker arm, or tie-rod sleeves [A] and needle bearings [B].
- The rollers in a needle bearing normally wear very little, and wear is difficult to measure. Instead of measuring, inspect the bearing for abrasion, color change, or other damage.
- ★ If there is any doubt as to the condition of any of the needle bearings or sleeve, replace the sleeve and needle bearings as a set.

Rocker Arm/Tie-Rod Bearing Lubrication**NOTE**

○ Since the bearings are packed with grease, lubrication is not required.

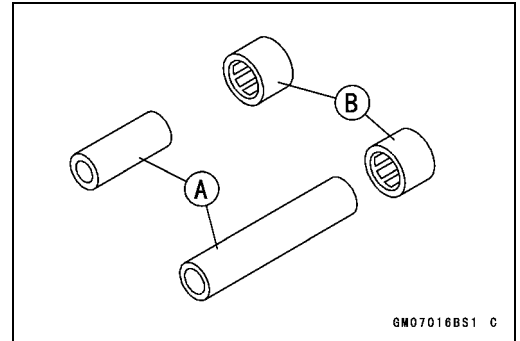

Steering

Table of Contents

- Exploded View 14-2
- Special Tools 14-4
- Steering 14-5
 - Steering Inspection 14-5
 - Steering Adjustment..... 14-5
- Steering Stem..... 14-6
 - Stem, Stem Bearing Removal..... 14-6
 - Stem, Stem Bearing Installation..... 14-7
 - Steering Stem Bearing Lubrication 14-9
 - Steering Stem Warp..... 14-9
 - Stem Cap Deterioration, Damage..... 14-9
- Handlebar 14-10
 - Handlebar Removal 14-10
 - Handlebar Installation 14-10

14-2 STEERING

Exploded View

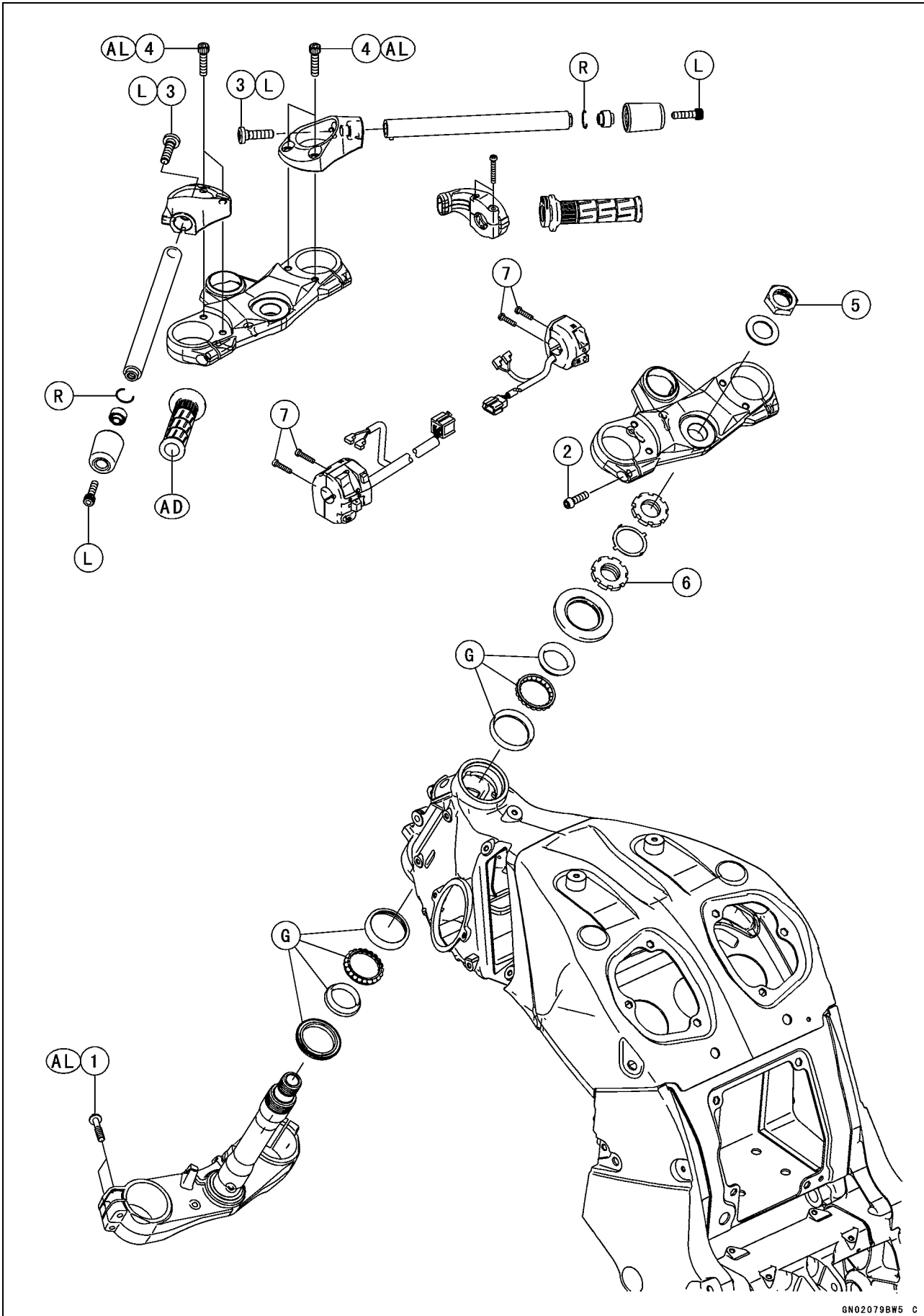

Exploded View

No.	Fastener	Torque			Remarks
		N·m	kgf·m	ft·lb	
1	Front Fork Clamp Bolts (Lower)	30	3.1	22	AL
2	Front Fork Clamp Bolts (Upper)	20	2.0	15	
3	Handlebar Bolts	34	3.5	25	L
4	Handlebar Holder Bolts	25	2.5	18	AL
5	Steering Stem Head Nut	78	8.0	58	
6	Steering Stem Nut	23	2.3	17	
7	Switch Housing Screws	3.5	0.36	31 in·lb	

AD: Apply adhesive.

AL: Tighten the two clamp bolts alternately two times to ensure even tightening torque.

G: Apply grease.

L: Apply a non-permanent locking agent.

R: Replacement Parts

14-4 STEERING

Special Tools

Head Pipe Outer Race Press Shaft:
57001-1075

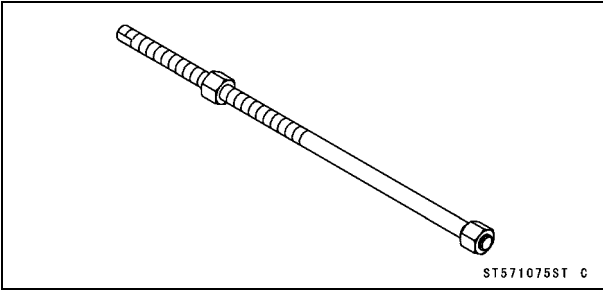

Steering Stem Bearing Driver, $\phi 42.5$:
57001-1344

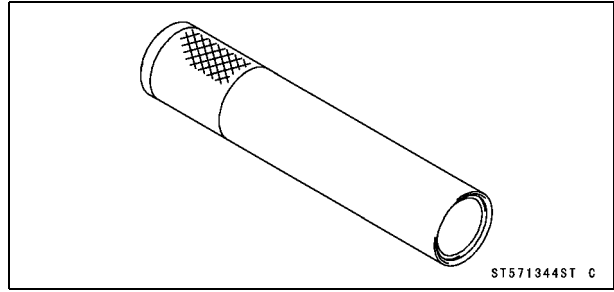

Steering Stem Nut Wrench:
57001-1100

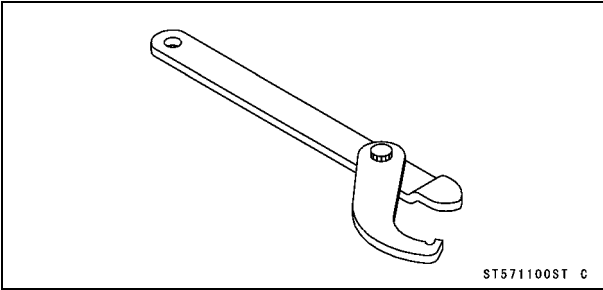

Steering Stem Bearing Driver Adapter, $\phi 41.5$:
57001-1345

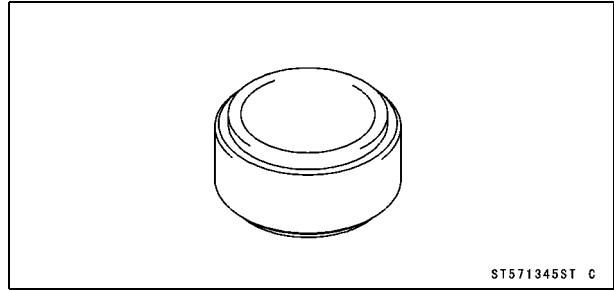

Bearing Driver Set:
57001-1129

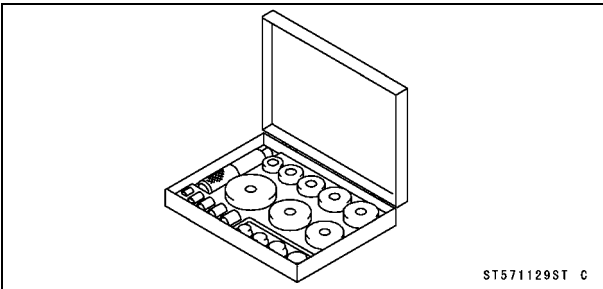

Head Pipe Outer Race Driver, $\phi 55$:
57001-1446

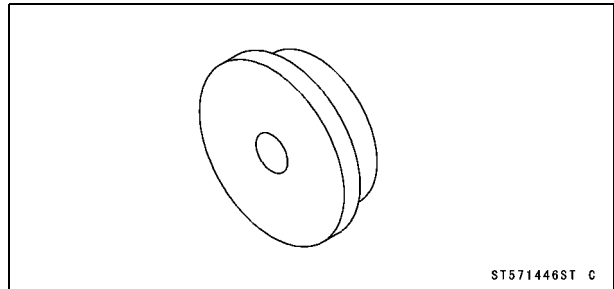

Steering

Steering Inspection

- Refer to the Steering Play Inspection in the Periodic Maintenance chapter.

Steering Adjustment

- Refer to the Steering Play Adjustment in the Periodic Maintenance chapter.

14-6 STEERING

Steering Stem

Stem, Stem Bearing Removal

- Remove:
 - Upper Fairing (see Upper Fairing Removal in the Frame chapter)
 - Front Wheel (see Front Wheel Removal in the Wheels/Tires chapter)
 - Handlebars (see Handlebar Removal)
 - Front Forks (see Front Fork Removal in the Suspension chapter)
 - Bracket Bolts [A]
 - Cover Bolts [B] and Cover [C]
- Remove:
 - Steering Stem Head Nut [A] and Washer [B]
 - Steering Stem Head [C]

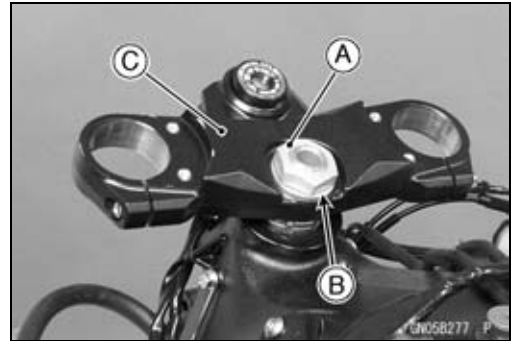
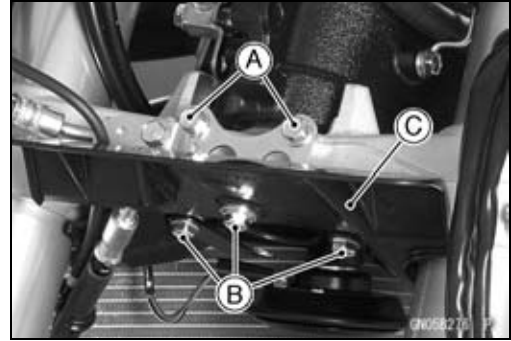

- Bend the claws [A] of lock washer straighten.
- Remove the steering stem locknut [B].
 - Special Tool - Steering Stem Nut Wrench: 57001-1100**
- Remove the lock washer.

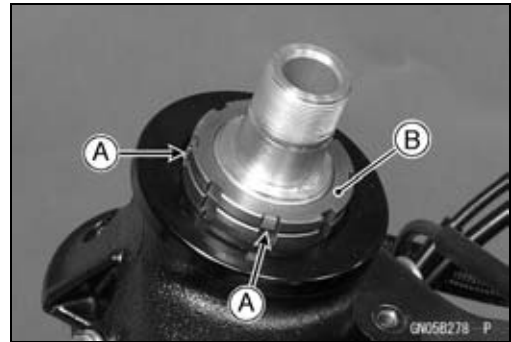

- Pushing up the stem base, and remove the steering stem nut [A] with stem cap [B].
 - Special Tool - Steering Stem Nut Wrench [C]: 57001-1100**
- Remove:
 - Steering Stem [D]
 - Upper Ball Bearing Inner Race and Ball Bearing

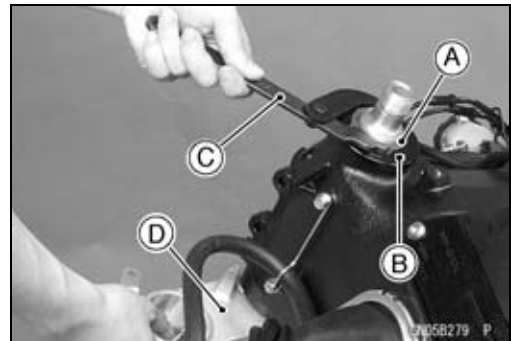

- To remove the ball bearing outer races [A] pressed into the head pipe [B], insert a bar [C] into the recesses [D] of head pipe, and applying it to both recess alternately hammer it to drive the race out.

NOTE

If either steering stem bearing is damaged, it is recommended that both the upper and lower bearings (including outer races) should be replaced with new ones.

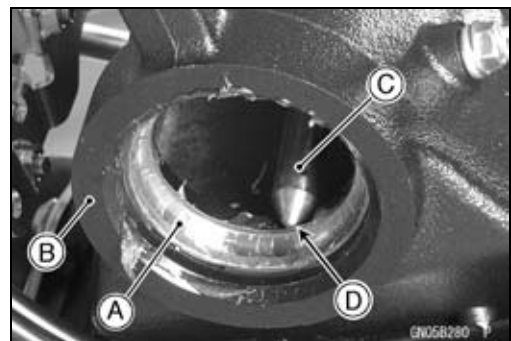

Steering Stem

- Remove the lower ball bearing inner race (with its oil seal) [A] which is pressed onto the steering stem with a suitable commercially available chisel [B].

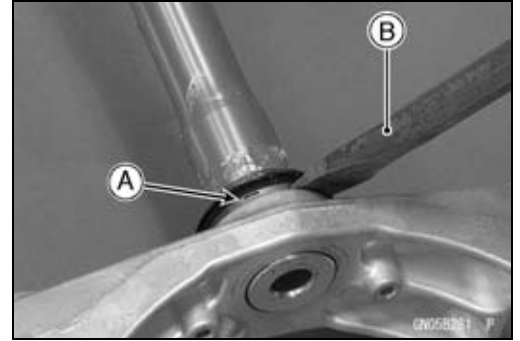

Stem, Stem Bearing Installation

- Replace the bearing outer races with new ones.
- Drive them into the head pipe at the same time.

Special Tools - Head Pipe Outer Race Press Shaft [A]:
57001-1075

Bearing Driver Set: 57001-1129

Head Pipe Outer Race Driver, $\phi 55$ [B]: 57001-1446

- Apply grease to the outer races.
- Replace the bearing inner races and oil seal with new ones.
- Apply grease to the oil seal.
- Install the oil seal [A] on the steering stem, and drive the lower ball bearing inner race [B] applied the grease onto the stem.

Special Tools - Steering Stem Bearing Driver, $\phi 42.5$ [C]:
57001-1344

Steering Stem Bearing Driver Adapter, $\phi 41.5$ [D]: 57001-1345

- Install the lower ball bearing [A] onto the stem.
- Grease the following.
 - Inner and Outer Races
 - Lower and Upper Ball Bearings
- The lower and upper ball bearings are identical.

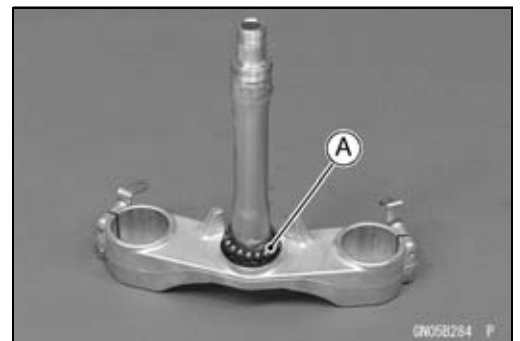
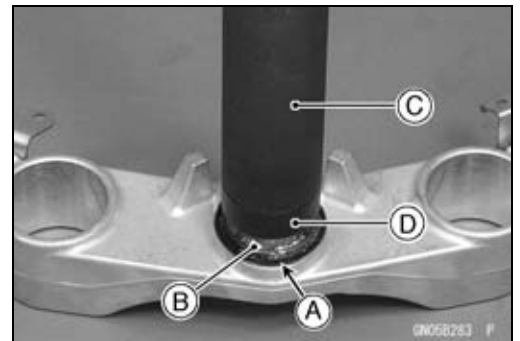
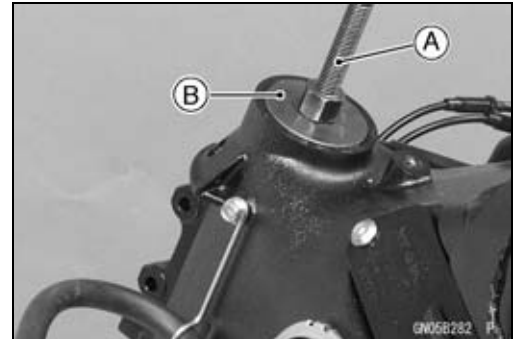

- Install the stem [A] through the head pipe and install the ball bearing [B] and inner race [C] on it.
- Install:
 - Stem Cap [D]
 - Steering Stem Nut [E]

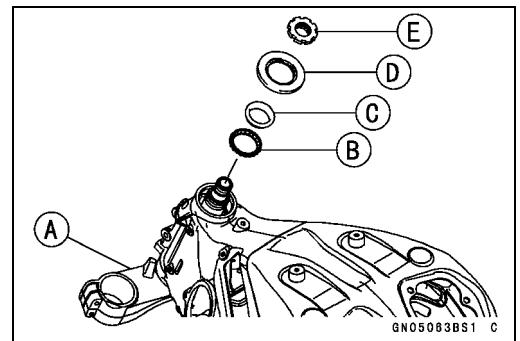

14-8 STEERING

Steering Stem

- Settle the bearings in place as follows.
- Tighten the steering stem nut with **55 N·m (5.6 kgf·m, 41 ft·lb)** of torque first, and loosen it a fraction of a turn until it turns lightly. Afterward tighten it again with specified torque using a steering stem nut wrench [A].

Special Tool - Steering Stem Nut Wrench: 57001-1100

Torque - Steering Stem Nut: 23 N·m (2.3 kgf·m, 17 ft·lb)

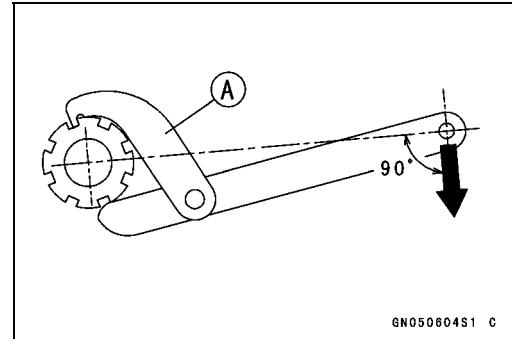

- Install the lock washer so that claw [A] of washer fit the notch [B] of steering stem locknut [C].

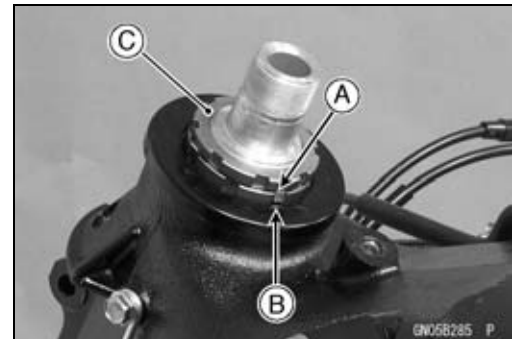

- First tighten the steering stem locknut by hand until the resistance is felt fully, then tighten the steering stem lock nut so that align the claw [A] of stem lock nut to the notch [B] of stem nut by hand.
- Check that there is no play and the steering stem turns smoothly without rattles. If not, the steering stem bearing may be damaged.
- Bend the claw of lock washer to steering stem nut notch.

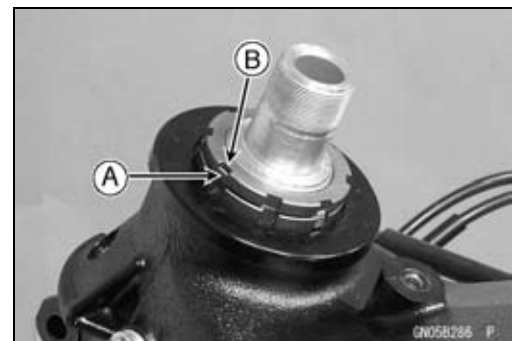

- Install the stem head [A] to the steering stem [B].
- Install the washer, and temporary tighten the stem head nut [C].
- Install the front forks (see Front Fork Installation in the Suspension chapter).

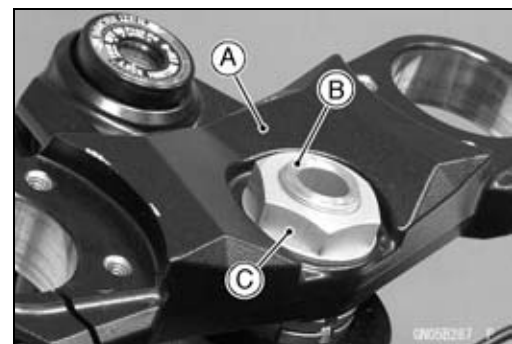

Steering Stem

NOTE

- Tighten the upper front fork clamp bolts [A] first, next the stem head nut [B], last the lower front fork clamp bolts [C].
- Tighten the two lower fork clamp bolts alternately two times to ensure even tightening torque.

Torque - Front Fork Clamp Bolts (Upper): 20 N·m (2.0 kgf·m, 15 ft·lb)

Steering Stem Head Nut: 78 N·m (8.0 kgf·m, 58 ft·lb)

Front Fork Clamp Bolts (Lower): 30 N·m (3.1 kgf·m, 22 ft·lb)

⚠ WARNING

Do not impede the handlebar turning by routing the cables, harnesses and hoses improperly (see Cable, Wire, and Hose Routing section in the Appendix chapter).

- Install the removed parts (see appropriate chapters).

Steering Stem Bearing Lubrication

- Refer to the Steering Stem Bearing Lubrication in the Periodic Maintenance chapter.

Steering Stem Warp

- Whenever the steering stem is removed, or if the steering can not be adjusted for smooth action, check the steering stem for straightness.
- ★ If the steering stem [A] is bent, replace the steering stem.

Stem Cap Deterioration, Damage

- ★ Replace the stem cap if its oil seal [A] shows damage.

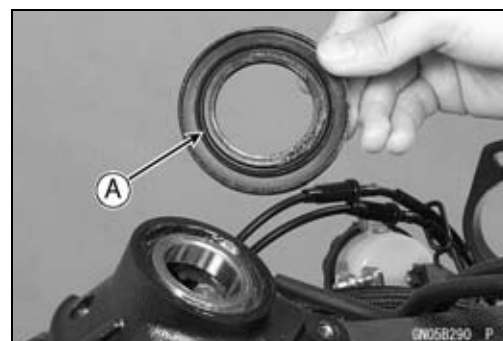
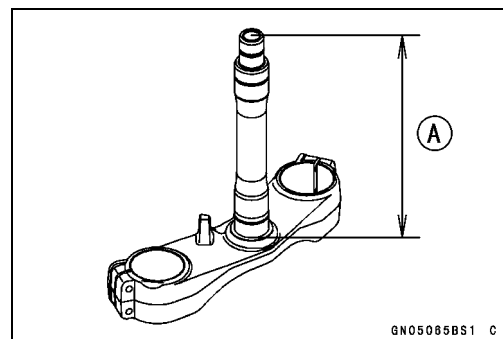
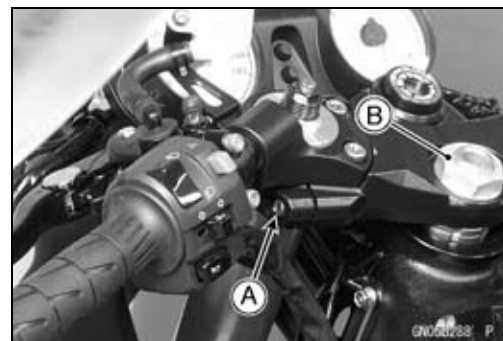

14-10 STEERING

Handlebar

Handlebar Removal

- Remove:
 - Clutch Lever Clamp Bolts [A]
 - Clutch Lever Assembly [B]
 - Left Switch Housing [C]
 - Handlebar Weight [D]

- Remove:
 - Front Master Cylinder [A] (see Front Master Cylinder Removal in the Brakes chapter)
 - Right Switch Housing [B]
 - Throttle Case [C]
 - Handlebar Weight [D]
 - Throttle Grip [E]

- Unscrew the handlebar holder bolts [A].
- Remove each handlebar holder [B] with handlebar [C].

- Hold the handlebar in a vise, and unscrew the handlebar bolt [A].
- Remove the handlebar.
- Remove the left handlebar grip.

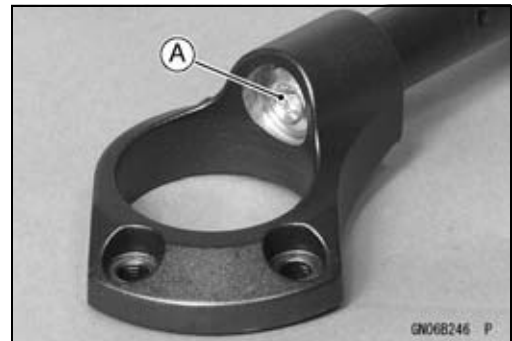
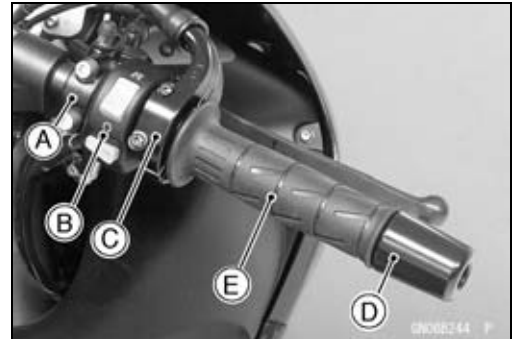
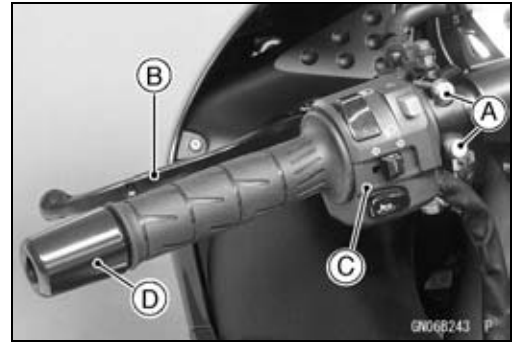

Handlebar Installation

- Apply adhesive cement to the inside of the left handlebar grip.
- Fit the pin [A] of the handlebar to the recess [B] of the handlebar holder.
- Apply a non-permanent locking agent to the threads of the handlebar bolts.
- Tighten:
 - Torque - Handlebar Bolts: 34 N·m (3.5 kgf·m, 25 ft·lb)**

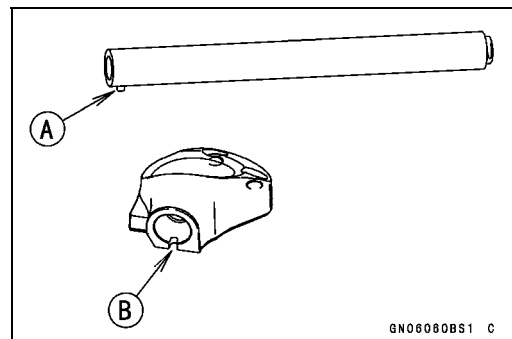

Handlebar

- Install the handlebar holder with handlebar on the steering stem head.
- Tighten the handlebar holder bolts.

NOTE

- Tighten the handlebar holder bolt [A] first, next the handlebar holder bolt [B].
- Tighten the two handlebar holder bolts alternately two times to ensure even tightening torque.

Torque - Handlebar Holder Bolts: 25 N·m (2.5 kgf·m, 18 ft·lb)

- Install the front master cylinder (see Front Master Cylinder Installation in the Brakes chapter).
- Install:
 - Throttle Grip
 - Throttle Cable Tips [A]
 - Throttle Cases [B]
- Fit the projection into a small hole in the handlebar.
- Apply a non-permanent locking agent to the threads of the handlebar weight bolts, and tighten them.

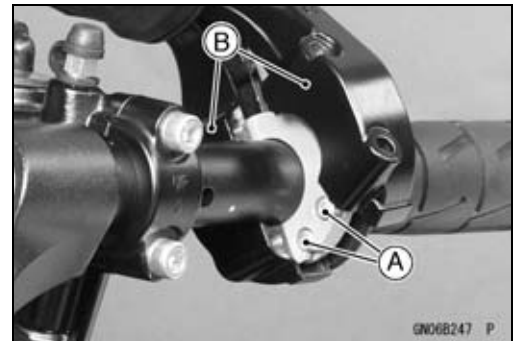
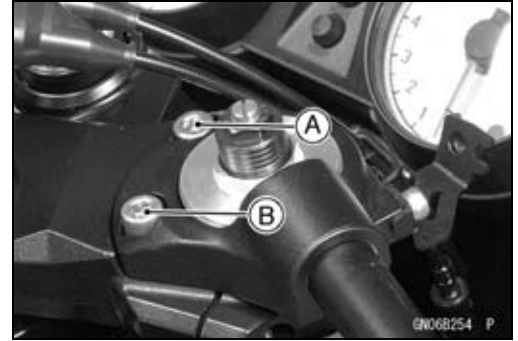

- Install the left and right switch housings.
 - Fit the projection [A] into a small hole [B] in the handlebar.
- Torque - Switch Housing Screws: 3.5 N·m (0.36 kgf·m, 31 in·lb)**
- Install the clutch lever (see Clutch Lever Installation in the Clutch chapter).

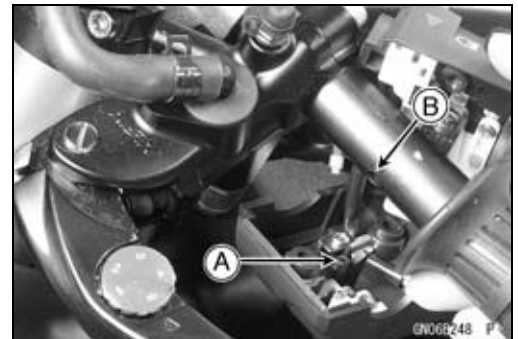

Frame

Table of Contents

Exploded View	15-2
Seat	15-10
Seat Removal	15-10
Seat Installation	15-10
Fairings	15-11
Lower Fairing Removal	15-11
Lower Fairing Installation	15-11
Fairing Cover Removal	15-11
Middle Fairing Removal	15-11
Middle Fairing Installation	15-12
Windshield Removal	15-12
Windshield Installation	15-13
Upper Fairing Removal	15-13
Upper Fairing Disassembly	15-13
Upper Fairing Assembly	15-13
Upper Fairing Installation	15-14
Inner Cover Removal	15-14
Inner Cover Installation	15-14
Upper Inner Fairing Removal	15-14
Upper Inner Fairing Installation	15-15
Upper Fairing Bracket Removal	15-15
Upper Fairing Bracket Installation	15-15
Inner Fairing Removal	15-15
Inner Fairing Installation	15-15
Rear Fairing Removal	15-15
Rear Fairing Installation	15-15
Seat Cover	15-16
Seat Cover Removal	15-16
Seat Cover Installation	15-16
Fenders	15-18
Front Fender Removal	15-18
Front Fender Installation	15-18
Flap and Rear Fender Removal	15-18
Flap and Rear Fender Installation	15-19
Frame	15-20
Rear Frame Removal	15-20
Rear Frame Installation	15-20
Frame Inspection	15-20
Center Stand, Sidestand	15-21
Center Stand Removal (Equipped Models)	15-21
Center Stand Installation (Equipped Models)	15-21
Sidestand Removal	15-21
Sidestand Installation	15-21

15-2 FRAME

Exploded View

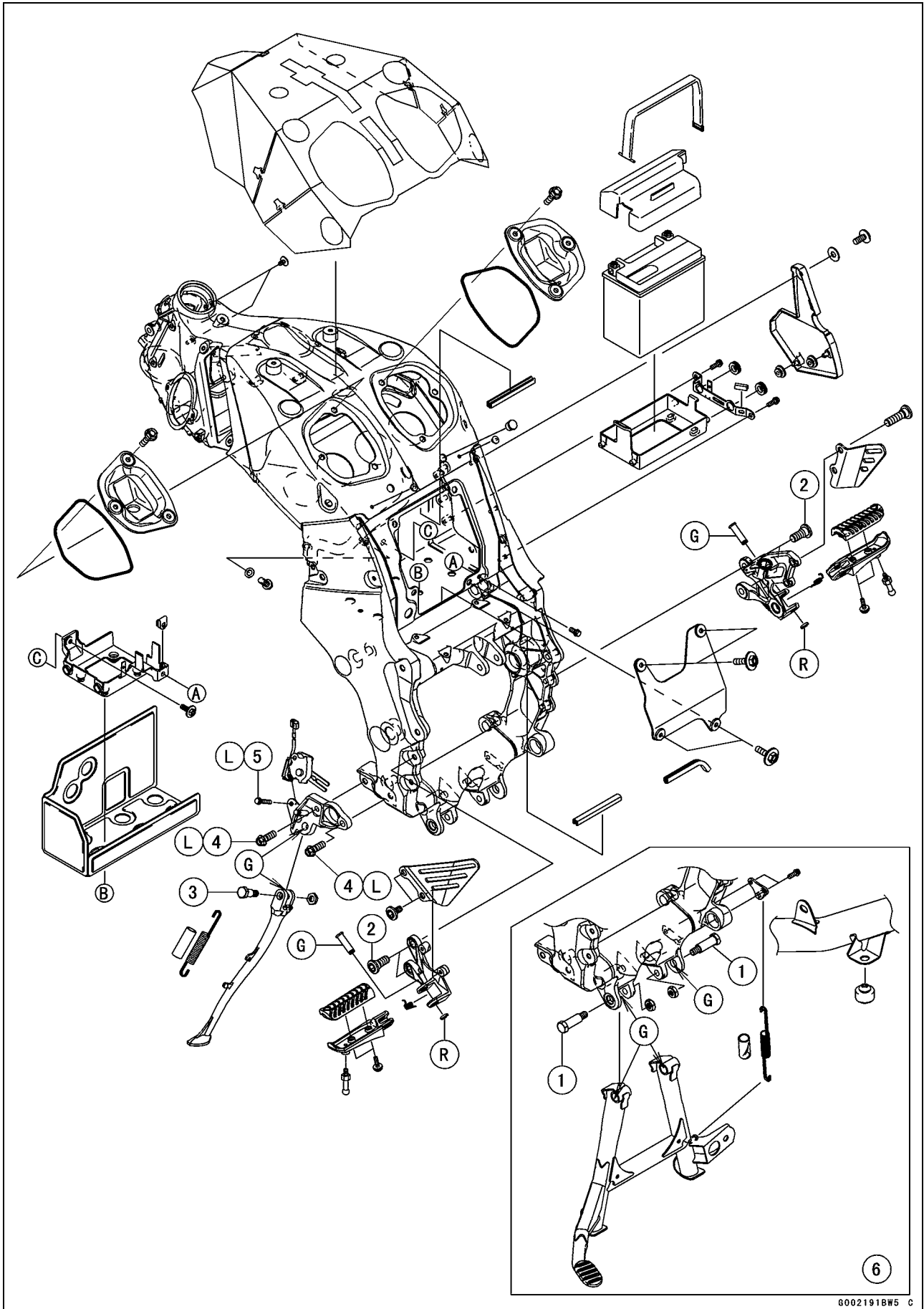

Exploded View

No.	Fastener	Torque			Remarks
		N·m	kgf·m	ft·lb	
1	Center Stand Bolts	44	4.5	32	
2	Front Footpeg Bracket Bolts	25	2.5	18	
3	Sidestand Bolt	44	4.5	32	
4	Sidestand Bracket Bolts	49	5.0	36	L
5	Sidestand Switch Bolt	8.8	0.90	78 in·lb	L

6. Center Stand (Equipped Models)

G: Apply grease.

L: Apply a non-permanent locking agent.

R: Replacement Parts

15-4 FRAME

Exploded View

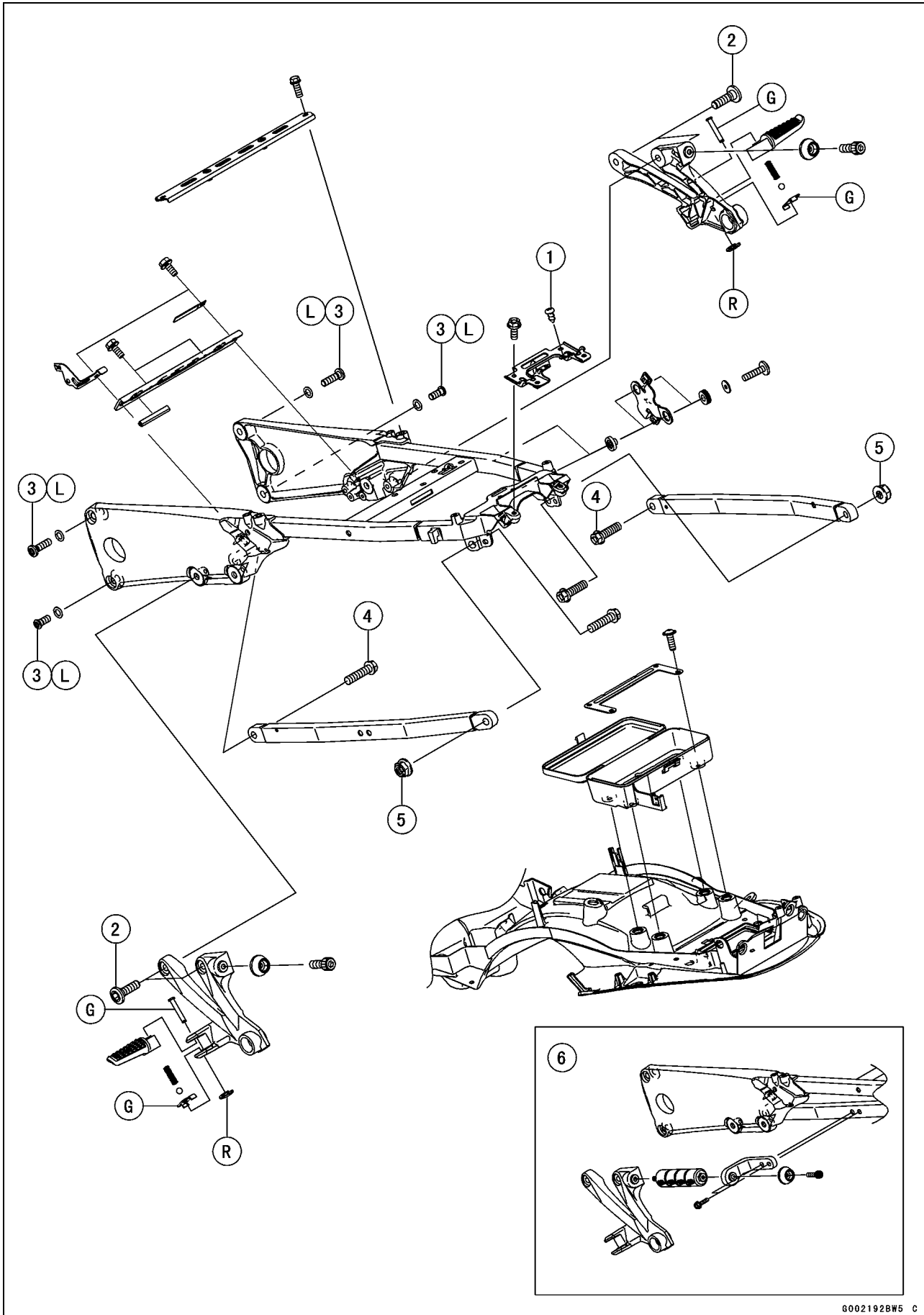

Exploded View

No.	Fastener	Torque			Remarks
		N·m	kgf·m	ft·lb	
1	Rear Fender Mounting Screws	1.2	0.12	11 in·lb	
2	Rear Footpeg Bracket Bolts	25	2.5	18	
3	Rear Frame Bolts	44	4.5	32	L
4	Rear Frame Pipe Bolts	44	4.5	32	
5	Rear Frame Pipe Nuts	44	4.5	32	

6. Center Stand Grip (Equipped Models)

G: Apply grease.

L: Apply a non-permanent locking agent.

R: Replacement Parts

15-6 FRAME

Exploded View

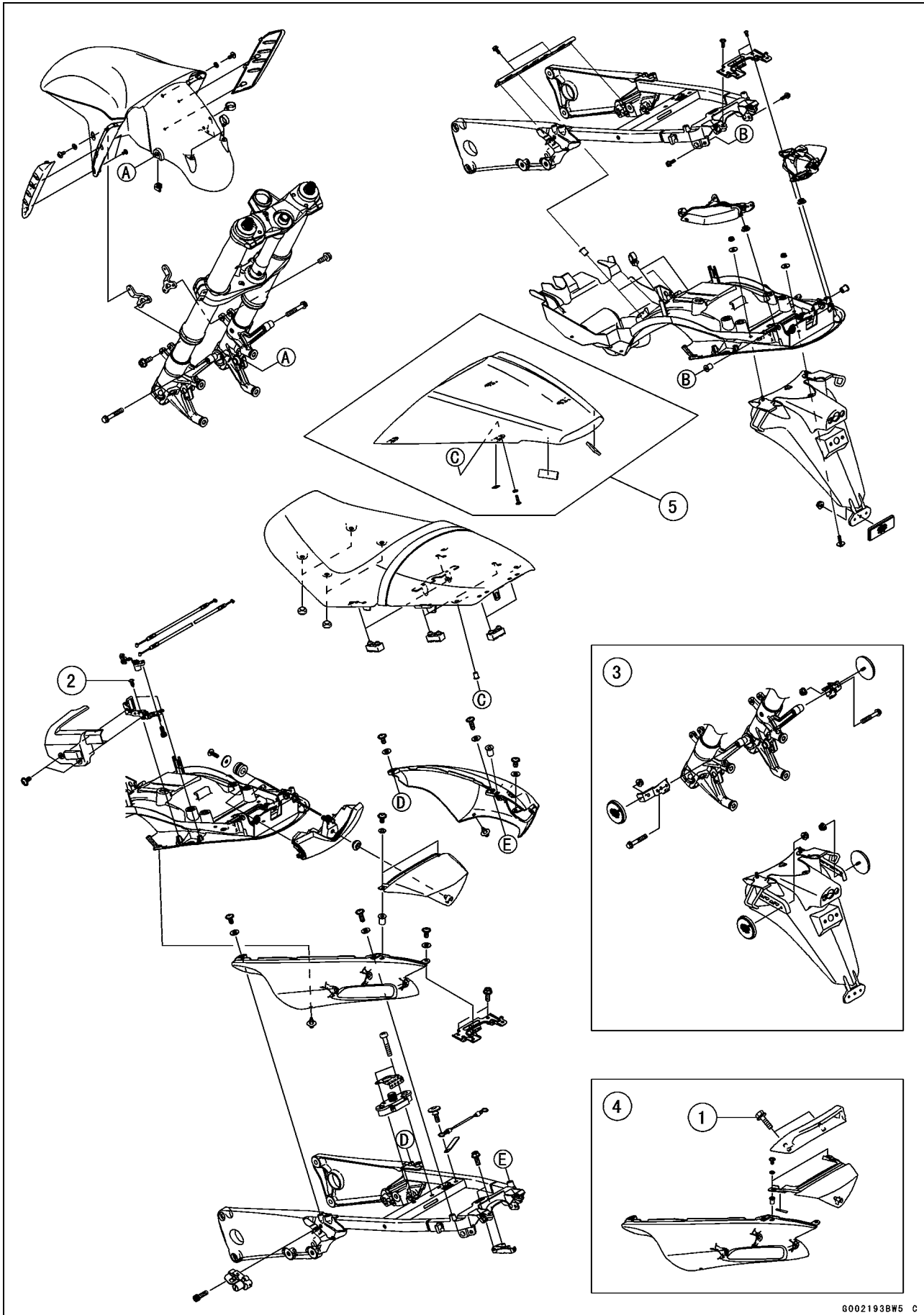

Exploded View

No.	Fastener	Torque			Remarks
		N·m	kgf·m	ft·lb	
1	Grab Rail Mounting Bolts	25	2.5	18	
2	Seat Lock Bracket Screws	1.2	0.12	11 in·lb	

3. Reflector (United States and Canada Models)

4. Grab Rail (Equipped Models)

5. Seat Cover (Equipped Models)

15-8 FRAME

Exploded View

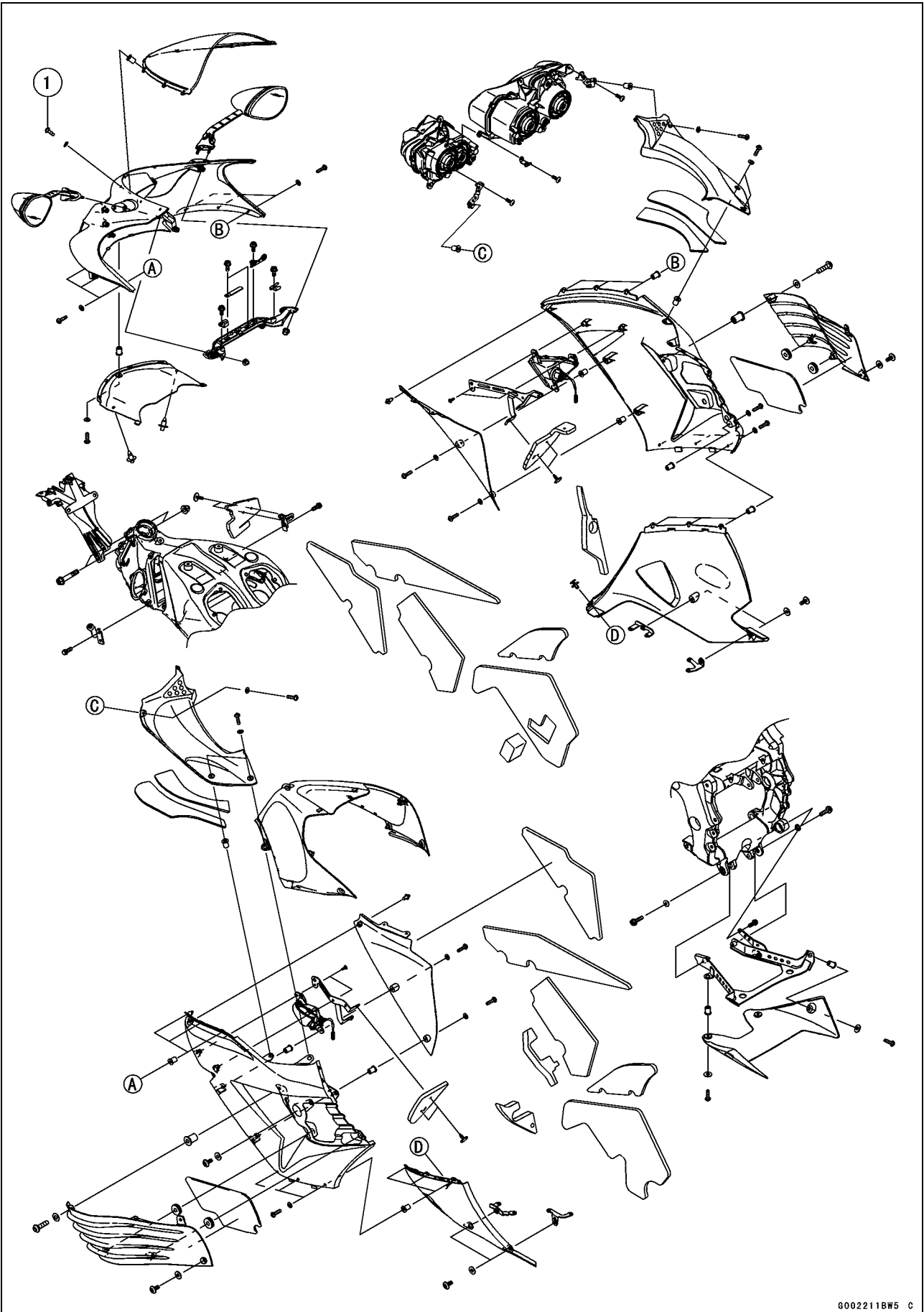

Exploded View

No.	Fastener	Torque			Remarks
		N·m	kgf·m	ft·lb	
1	Windshield Mounting Bolts	0.42	0.043	3.7 in·lb	

15-10 FRAME

Seat

Seat Removal

- Insert the ignition switch key [A] into the seat lock, turning the key counterclockwise, pulling up on the rear of the seat [B], and pulling the seat backward.



- For seat cover equipped models; note the following.
- Remove:
 - Bolts [A]
 - Seat Cover [B]

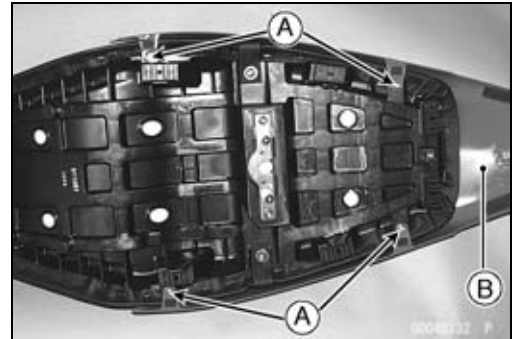

Seat Installation

- Insert the brackets [A] of the fuel tank into the slots [B] of the seat.

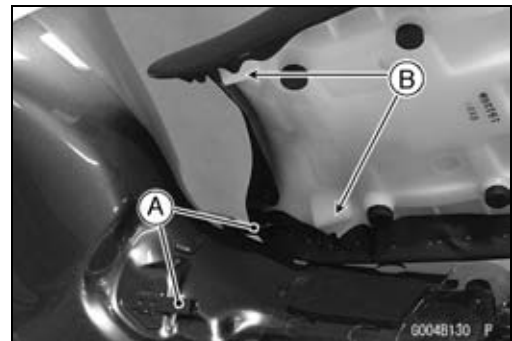

- Insert the projections [A] of the seat into the slots [B] of the frame, and insert the seat hook [C] into the slot [D] of the frame.
- Push down the rear part of the seat until the lock clicks.

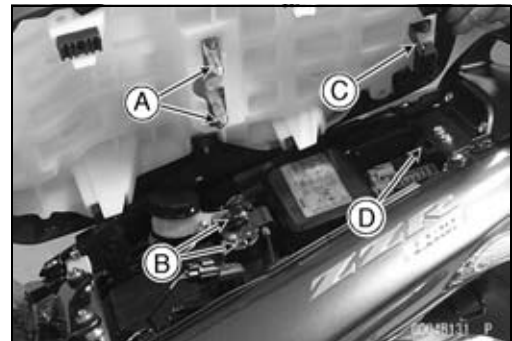

Fairings

Lower Fairing Removal

- Pull up the core by the thin blade driver.
- Remove the quick rivet [A].
- Remove the bolts [B] with washers.
- Clear the hook portions from the slots.
- Separate the left lower fairing from the right lower fairing.

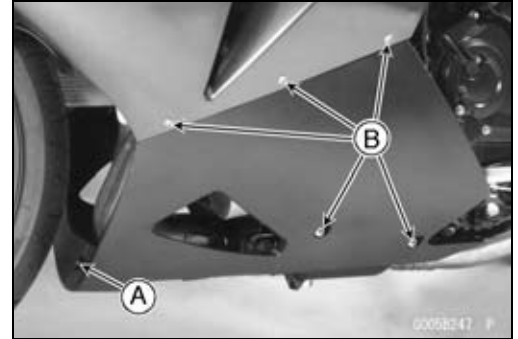

Lower Fairing Installation

- Insert the hook portions [A] into the slots [B].
- Tighten the bolts with washers.
- Set the quick rivet and push the core.

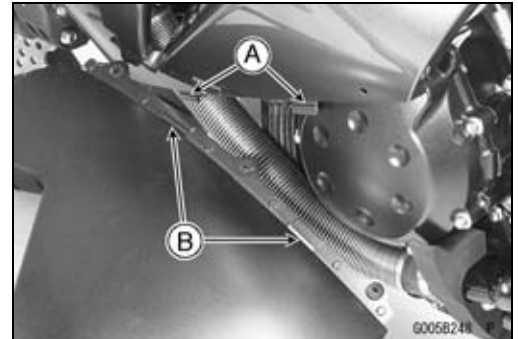

Fairing Cover Removal

- Remove the bolts [A].
- Pull out the fairing cover [B], and clear the stoppers.

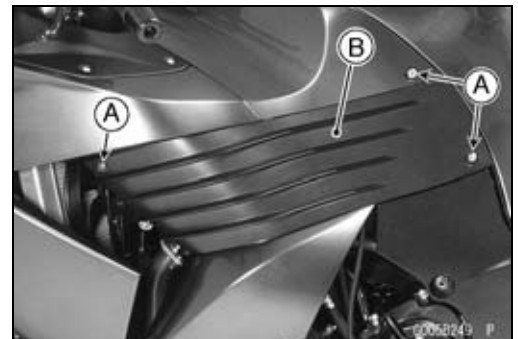

- Insert the projections [A] into the holes [B].
- Tighten the bolts.



Middle Fairing Removal

- Remove:
 - Lower Fairings (see Lower Fairing Removal)
 - Fairing Covers (see Fairing Cover Removal)
 - Inner Covers (see Inner Cover Removal)
 - Fuel Tank Cover (see Fuel Tank Removal in the Fuel System (DFI) chapter)
- Push the central pin, and then remove the quick rivets [A].



15-12 FRAME

Fairings

- Remove:
 - Bolts [A] with Washers
 - Turn Signal Lead Connector
- Remove each middle fairing.
- Clear the hook [B] from the bracket.

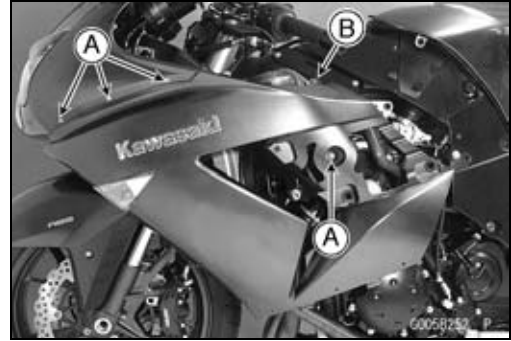

- Remove:
 - Inner Fairing (see Inner Fairing Removal)
 - Screws
 - Bracket
 - Turn Signal Light

Middle Fairing Installation

- Install the turn signal light to the middle fairing, and tighten the screws.
- Install the inner fairing (see Inner Fairing Installation).
- Connect the turn signal lead connector.
- Hang the hook of the middle fairing to the bracket.
- Install the washers and bolts.
- Install the quick rivets.
- Install the removed parts (see appropriate chapters).

Windshield Removal

- Remove:
 - Bolts [A] with Washers
 - Windshield [B]

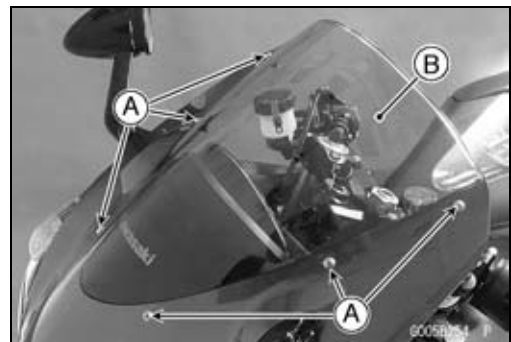

Fairings

Windshield Installation

- Put the front tongue [A] into the hollow [B].
- Tighten:
Torque - Windshield Mounting Bolts: 0.42 N·m (0.043 kgf·m, 3.7 in·lb)

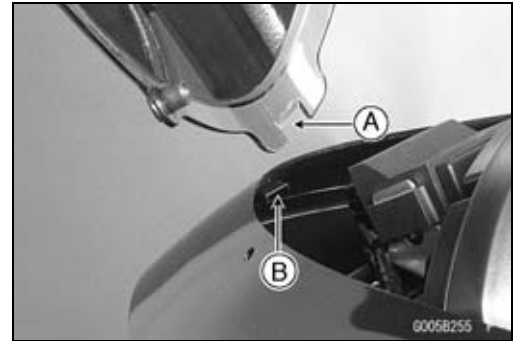

Upper Fairing Removal

- Remove:
 Lower Fairings (see Lower Fairing Removal)
 Fairing Covers (see Fairing Cover Removal)
 Inner Covers (see Inner Cover Removal)
 Middle Fairings (see Middle Fairing Removal)
 Windshield (see Windshield Removal)
 Vehicle-down Sensor Lead Connector
 Immobilizer Amplifier Lead Connector (Equipped Models)
- Unscrew the bracket screws [A].
- Disconnect:
 Headlight Lead Connectors [A] (Both Sides)
 City Light Lead Connectors [B] (Both Sides)

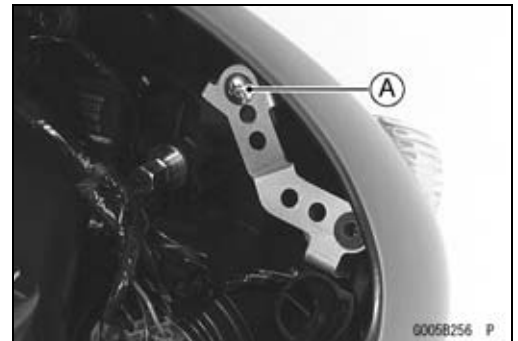

- Remove the bolts [A].
- Pull out the upper fairing forward.

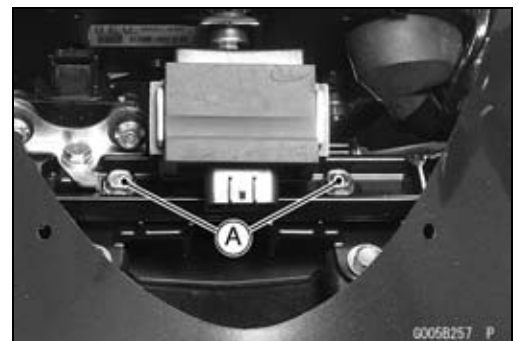

Upper Fairing Disassembly

- Remove:
 Upper Fairing (see Upper Fairing Removal)
 Upper Inner Fairing (see Upper Inner Fairing Removal)
 Headlights [A] (see Headlight Removal in the Electrical System chapter)
 Nuts [B] and Rear View Mirrors (Both Sides)

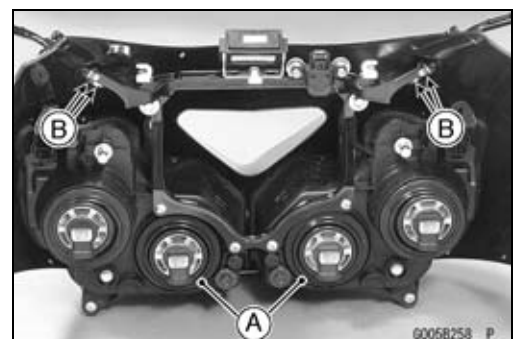

Upper Fairing Assembly

- Installation is the reverse of removal.

15-14 FRAME

Fairings

Upper Fairing Installation

- Installation is the reverse of removal.

Inner Cover Removal

- Remove the bolts [A].
- Remove the inner cover [B].
- Pull the inner cover backward, and clear the hooks.

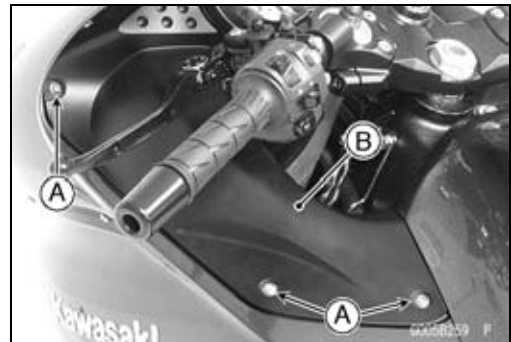

Inner Cover Installation

- Insert the hooks [A] into the slots [B].
- Tighten the bolts.

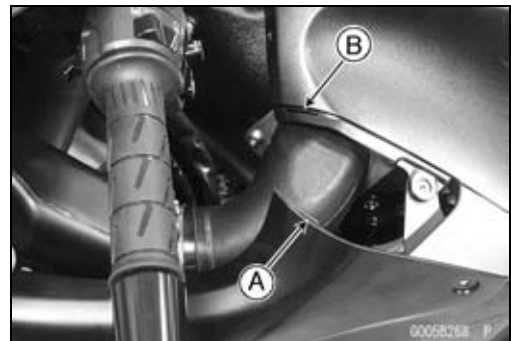
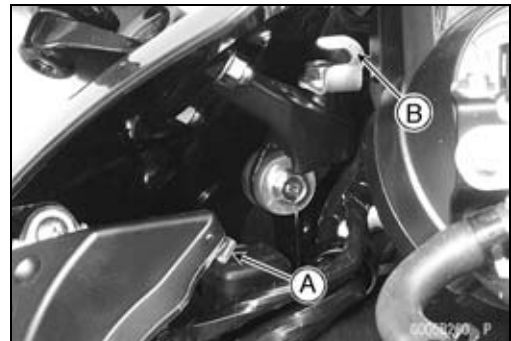

Upper Inner Fairing Removal

- Remove:
 - Upper Fairing (see Upper Fairing Removal)
 - Bolt [A]
 - Upper Inner Fairing [B]
- Slide out the upper inner fairing backward.

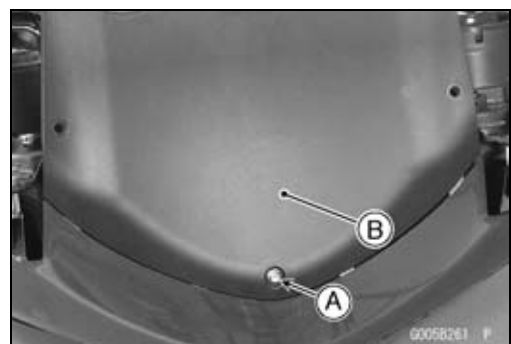

Fairings

Upper Inner Fairing Installation

- Insert the slots [A] of the upper inner fairing into the hooks [B] of the upper fairing.
- Tighten the bolt.

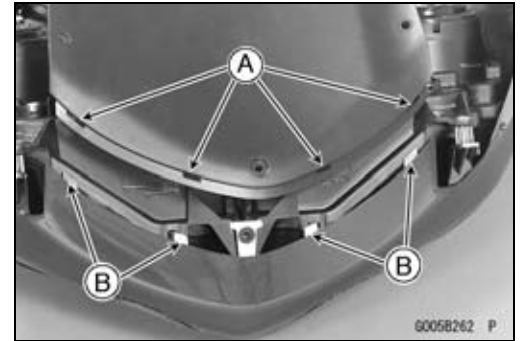

Upper Fairing Bracket Removal

- Remove:
 - Upper Fairing (see Upper Fairing Removal)
 - Front and Middle Inlet Ducts (see Front and Middle Inlet Duct Removal in the Fuel System (DFI) chapter)
 - Rear Inlet Ducts (see Rear Inlet Duct Removal in the Fuel System (DFI) chapter)
 - Meter Unit (see Meter Unit Removal in the Electrical System chapter)
 - Headlight Relays [A]
 - Bolts [B]
 - Upper Fairing Bracket [C]

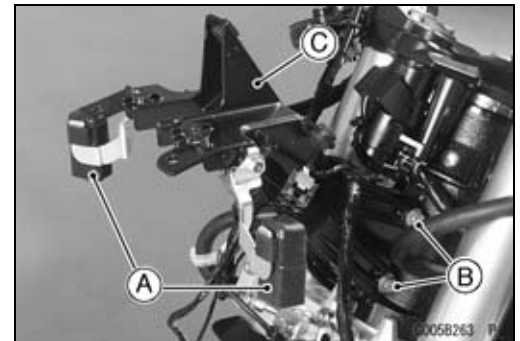

Upper Fairing Bracket Installation

- Installation is the reverse of removal.

Inner Fairing Removal

- Remove:
 - Middle Fairings (see Middle Fairing Removal)
 - Quick Rivet [A]
 - Bolts [B]
 - Inner Fairing [C]

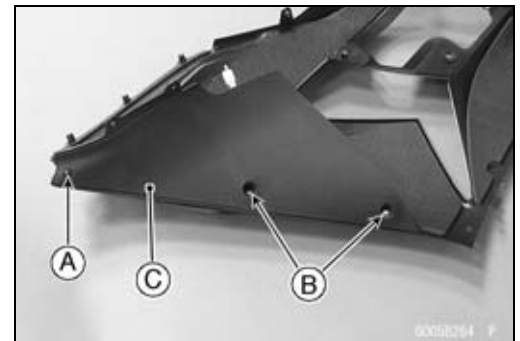

Inner Fairing Installation

- Installation is the reverse of removal.

Rear Fairing Removal

- Remove:
 - Bolts [A]
 - Rear Fairing [B]

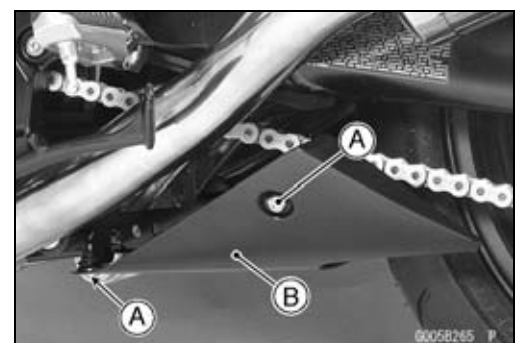

Rear Fairing Installation

- Installation is the reverse of removal.

15-16 FRAME

Seat Cover

Seat Cover Removal

- Remove:
 - Seat (see Seat Removal)
 - Bolts [A]
 - Screws [B]
 - Grab Rail [C] (Equipped Models)
 - Center Seat Cover [D]

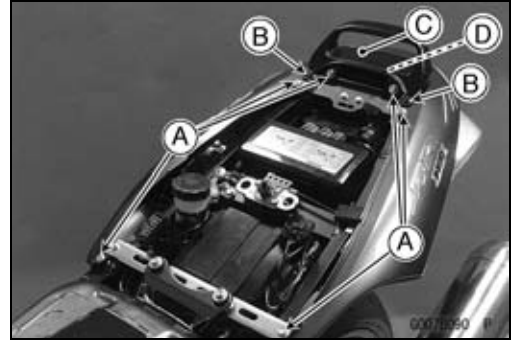

- Remove the quick rivets [A].

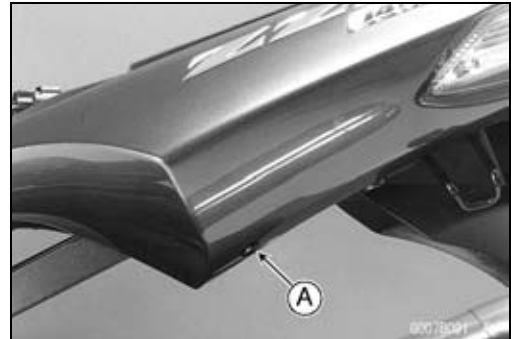

- Remove the bolts [A].
- Clear the side seat covers [B] from the rear fender.
- Disconnect the turn signal lead connectors, and remove each side seat cover.

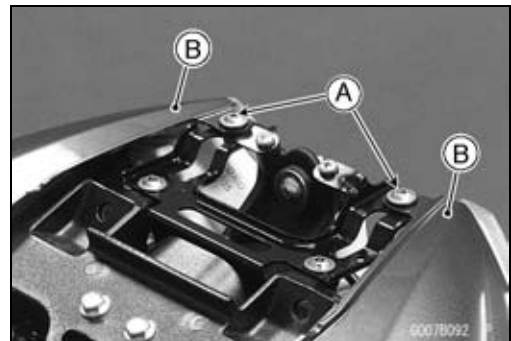

- Remove:
 - Screws [A]
 - Turn Signal Light [B]

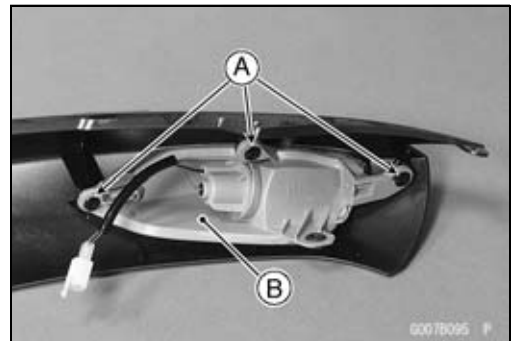

Seat Cover Installation

- Connect the turn signal lead connector.
- Insert the hole [A] to the projection [B].
- Install the bolts and quick rivets.

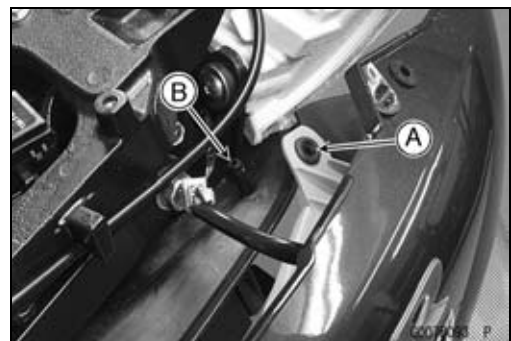

Seat Cover

- Insert the projection [A] into the hole [B].
- Tighten the screws.
- Install the grab rail (equipped models).
- Tighten:

Torque - Grab Rail Mounting Bolts: 25 N·m (2.5 kgf·m, 18 ft·lb)

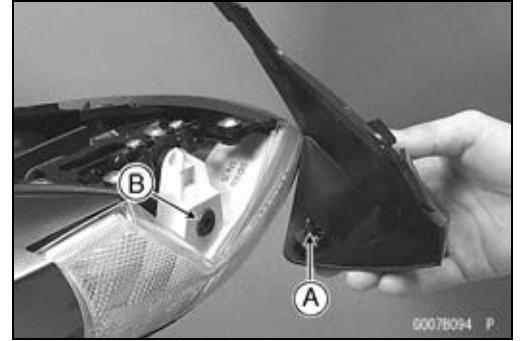

15-18 FRAME

Fenders

Front Fender Removal

- Remove:
 - Brake Hose Clamps [A] (Both Sides)
 - Bolts [B] with Washer (Both Sides)
 - Bracket [C] (ZX1400B Models)
- Remove the front fender assy [D].

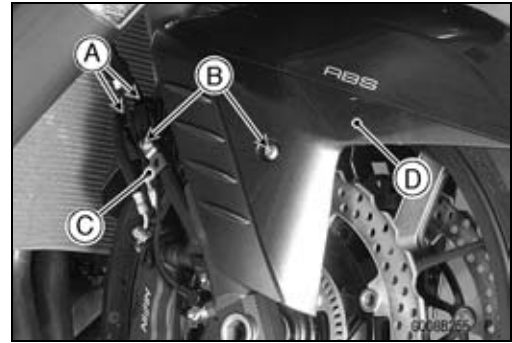

- Remove the screws [A].
- Separate the front fender covers [B] and front fender [C].

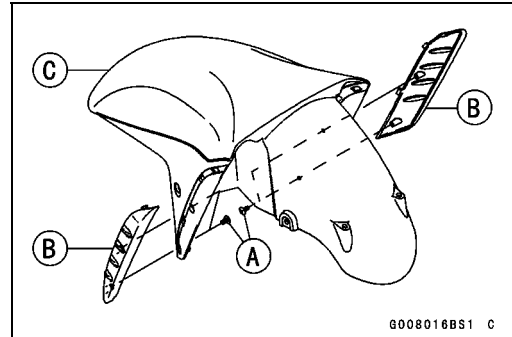

Front Fender Installation

- Install the front fender covers to the front fender.
- Insert the hooks [A] of the front fender cover into the slots [B] of the front fender.

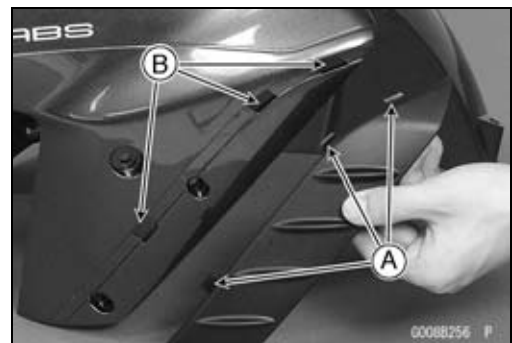

- Install the front fender assy to the front fork.
- Install the brake hose clamps to the front fender holes.

Flap and Rear Fender Removal

- Remove:
 - Seat (see Seat Removal)
 - Seat Covers (see Seat Cover Removal)
 - Fuel Tank (see Fuel Tank Removal in the Fuel System (DFI) chapter)
 - Tool Kit Case [A] (see ECU Removal in the Fuel System (DFI) chapter)
 - Relay Box [B] (see Relay Box Removal in the Electrical System chapter)
 - ECU (see ECU Removal in the Fuel System (DFI) chapter)
 - Rear Wheel (see Rear Wheel Removal in the Wheels/Tires chapter)
 - Fuse Box [C]
 - Bolts [D] and Cover [E]
 - Seat Lock
 - Bolts [F]
 - Screws [G]

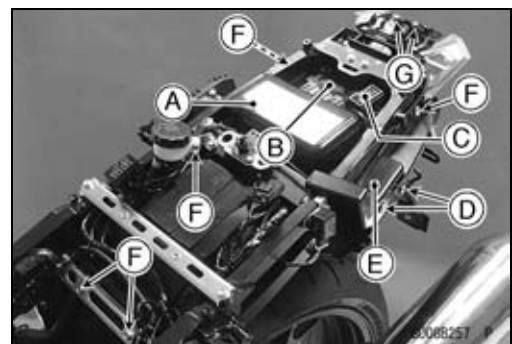

Fenders

- Remove:
 - Nuts [A]
 - License Light Connector (Disconnect)
 - Flap (with License Light)
 - Tail/Brake Light (LED) (see Tail/Brake Light (LED) Removal in the Electrical System chapter)
- Pull out the rear fender [B] backward and downward.

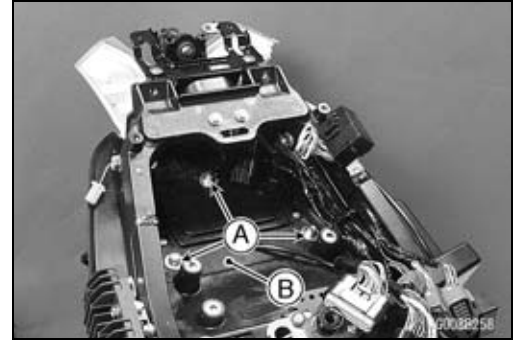

Flap and Rear Fender Installation

- Hang the hook [A] of the rear fender to the slot [B] of the rear frame.
- Tighten:
 - Torque - Rear Fender Mounting Screws: 1.2 N·m (0.12 kgf·m, 11 in·lb)**
- Install the removed parts (see appropriate chapters).
- Run the harness correctly (see Cable, Wire, and Hose Routing section in the Appendix chapter).

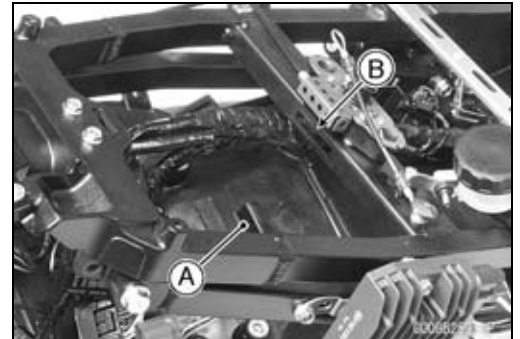

15-20 FRAME

Frame

Rear Frame Removal

- Remove:
 - Rear Fender (see Rear Fender Removal)
 - Regulator/Rectifier [A] (see Regulator/Rectifier Inspection in the Electrical System chapter)
 - Tail/Brake Light (see Tail/Brake Light Removal in the Electrical System chapter)
 - Bolts [B] (Both Sides)
 - Rear Footpeg Bracket Bolts [C] and Brackets (Both Sides)
 - Frame Bolts [D]

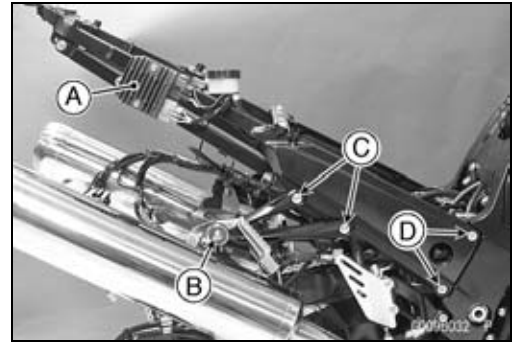

Rear Frame Installation

- Apply a non-permanent locking agent to the thread of the rear frame bolt, and tighten them.
 - Torque - Rear Frame Bolts: 44 N·m (4.5 kgf·m, 32 ft·lb)
 - Rear Footpeg Bracket Bolts: 25 N·m (2.5 kgf·m, 18 ft·lb)
- Install the removed parts (see appropriate chapters).

Frame Inspection

- Visually inspect the frame [A] for cracks, dents, bending, or warp.
- ★ If there is any damage to the frame, replace it.

⚠ WARNING

A repaired frame may fail in use, possibly causing an accident. If the frame is bent, dented, cracked, or warped, replace it.

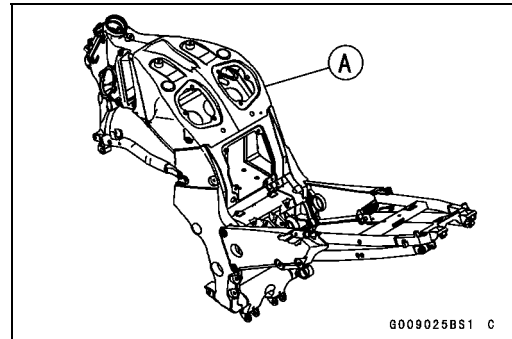

G009025BS1 C

Center Stand, Sidestand

Center Stand Removal (Equipped Models)

- Remove:
 - Muffler Bodies (see Muffler Body Removal in the Engine Top End chapter)
 - Spring [A]
 - Bolts [B]
 - Bolts [C] and Nuts
 - Center Stand [D]

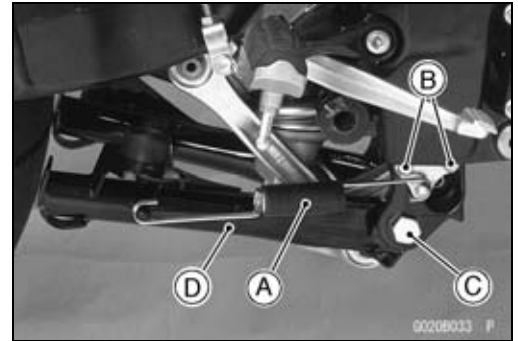

Center Stand Installation (Equipped Models)

- Apply grease to the sliding area [A] of the center stand [B].
- Tighten the bolts [C] and lock them with the nuts.
 - Torque - Center Stand Bolts: 44 N·m (4.5 kgf·m, 32 ft·lb)**
- Hook the spring [D] so that face the long spring end upward.
- Install the spring hook direction as shown in the figure.

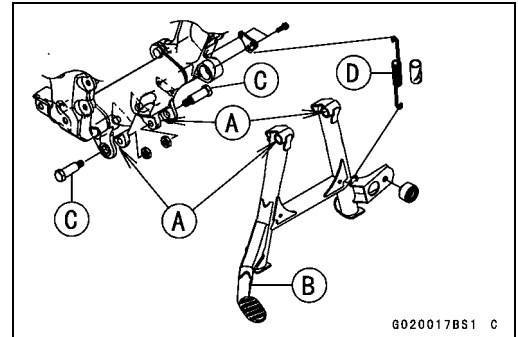

Sidestand Removal

- Raise the rear wheel off the ground with the stand.
- Remove:
 - Sidestand Switch Bolt [A]
 - Spring [B]
 - Sidestand Bolt [C]
 - Sidestand [D]
 - Sidestand Bracket Bolts [E]

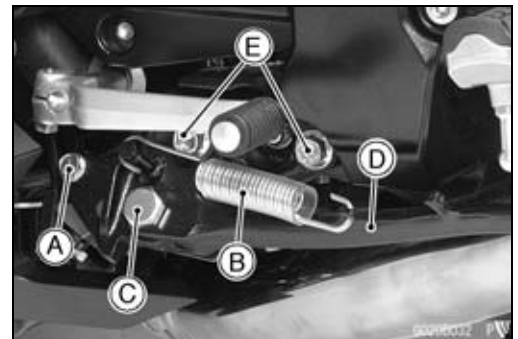

Sidestand Installation

- Apply grease to the sliding area [A] of the sidestand [B].
- Tighten the bolt and lock them with the nut.
 - Torque - Sidestand Bracket Bolts [C]: 49 N·m (5.0 kgf·m, 36 ft·lb)**
 - Sidestand Bolt [D]: 44 N·m (4.5 kgf·m, 32 ft·lb)**
- Hook the spring [E] so that face the long spring end upward.
- Install the spring hook direction as shown in the figure.
- Install the sidestand switch.
- Apply a non-permanent locking agent to the thread of the switch bolt, and tighten it.
 - Torque - Sidestand Switch Bolt [F]: 8.8 N·m (0.90 kgf·m, 78 in·lb)**

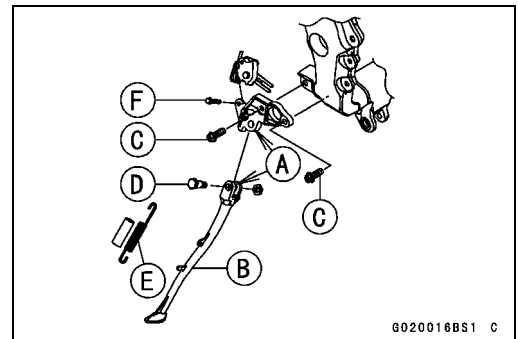

Electrical System

Table of Contents

Exploded View.....	16-4
Parts Location.....	16-10
Wiring Diagram (United States, Canada, New Zealand and Colombia).....	16-12
Wiring Diagram (Other than United States, Canada, New Zealand and Colombia).....	16-14
Wiring Diagram (ZX1400B Models).....	16-16
Specifications	16-18
Special Tools and Sealant	16-19
Precautions.....	16-21
Electrical Wiring.....	16-22
Wiring Inspection	16-22
Battery	16-23
Battery Removal	16-23
Battery Installation	16-24
Battery Activation.....	16-24
Precautions	16-27
Interchange.....	16-27
Charging Condition Inspection.....	16-27
Refreshing Charge.....	16-28
Charging System.....	16-29
Alternator Cover Removal.....	16-29
Alternator Cover Installation.....	16-29
Stator Coil Removal	16-29
Stator Coil Installation	16-30
Alternator Rotor Removal	16-30
Alternator Rotor Installation	16-30
Alternator Inspection	16-31
Regulator/Rectifier Inspection.....	16-33
Charging Voltage Inspection	16-34
Ignition System.....	16-36
Crankshaft Sensor Removal.....	16-37
Crankshaft Sensor Installation	16-38
Crankshaft Sensor Inspection.....	16-38
Crankshaft Sensor Peak Voltage Inspection.....	16-38
Stick Coil (Ignition Coil together with Spark Plug Cap) Removal.....	16-39
Stick Coil (Ignition Coil together with Spark Plug Cap) Installation.....	16-39
Stick Coil (Ignition Coil together with Spark Plug Cap) Inspection.....	16-40
Stick Coil Primary Peak Voltage	16-40
Spark Plug Removal	16-41
Spark Plug Installation	16-41
Spark Plug Condition Inspection.....	16-41
Camshaft Position Sensor Removal	16-42
Camshaft Position Sensor Installation	16-42
Camshaft Position Sensor Inspection.....	16-42
Camshaft Position Sensor Peak Voltage Inspection.....	16-43
Interlock Operation Inspection	16-43
IC Igniter Inspection.....	16-44
Electric Starter System.....	16-46
Starter Motor Removal.....	16-46
Starter Motor Installation.....	16-46
Starter Motor Disassembly.....	16-47

16-2 ELECTRICAL SYSTEM

Starter Motor Assembly	16-47
Brush Inspection	16-48
Commutator Cleaning and Inspection.....	16-49
Armature Inspection.....	16-49
Brush Lead Inspection	16-49
Right-hand End Cover Assembly Inspection	16-50
Starter Relay Inspection.....	16-50
Lighting System.....	16-52
Headlight Beam Horizontal Vertical Adjustment	16-52
Headlight Beam Vertical Adjustment.....	16-52
Headlight Bulb Replacement	16-52
City Light Bulb Replacement.....	16-53
Headlight Removal/Installation	16-53
Headlight Relay Inspection	16-54
Tail/Brake Light (LED) Removal.....	16-54
Tail/Brake Light (LED) Installation.....	16-55
License Plate Light Bulb Replacement	16-55
Turn Signal Light Bulb Replacement	16-56
Turn Signal Relay Inspection	16-58
Air Switching Valve	16-60
Air Switching Valve Operation Test.....	16-60
Air Switching Valve Unit Test	16-60
Radiator Fan System.....	16-61
Fan Motor Inspection	16-61
Meter, Gauge, Indicator Unit.....	16-62
Meter Unit Removal	16-62
Meter Unit Installation	16-62
Meter Unit Disassembly	16-63
Meter Unit Inspection	16-63
Immobilizer System (Equipped Models).....	16-80
Operational Cautions	16-80
Key Registration.....	16-80
Immobilizer System Parts Replacement.....	16-96
ECU (Electric Control Unit) Replacement (for Immobilizer Models)	16-97
Immobilizer System Inspection	16-98
Switches and Sensors.....	16-100
Brake Light Timing Inspection.....	16-100
Brake Light Timing Adjustment	16-100
Switch Inspection	16-100
Water Temperature Sensor Inspection	16-101
Speed Sensor Removal	16-101
Speed Sensor Installation	16-101
Speed Sensor Inspection.....	16-102
Fuel Level Sensor Inspection.....	16-102
Fuel Reserve Switch Inspection.....	16-103
Gear Position Switch Removal	16-104
Gear Position Switch Installation	16-105
Gear Position Switch Inspection	16-105
Relay Box.....	16-106
Relay Box Removal	16-106
Relay Circuit Inspection	16-106
Diode Circuit Inspection	16-107
Fuse.....	16-109
30 A Main Fuse Removal.....	16-109
Fuse Box Fuse Removal.....	16-109
15 A ECU Fuse Removal.....	16-110
Fuse Installation.....	16-110

Fuse Inspection.....	16-111
----------------------	--------

16-4 ELECTRICAL SYSTEM

Exploded View

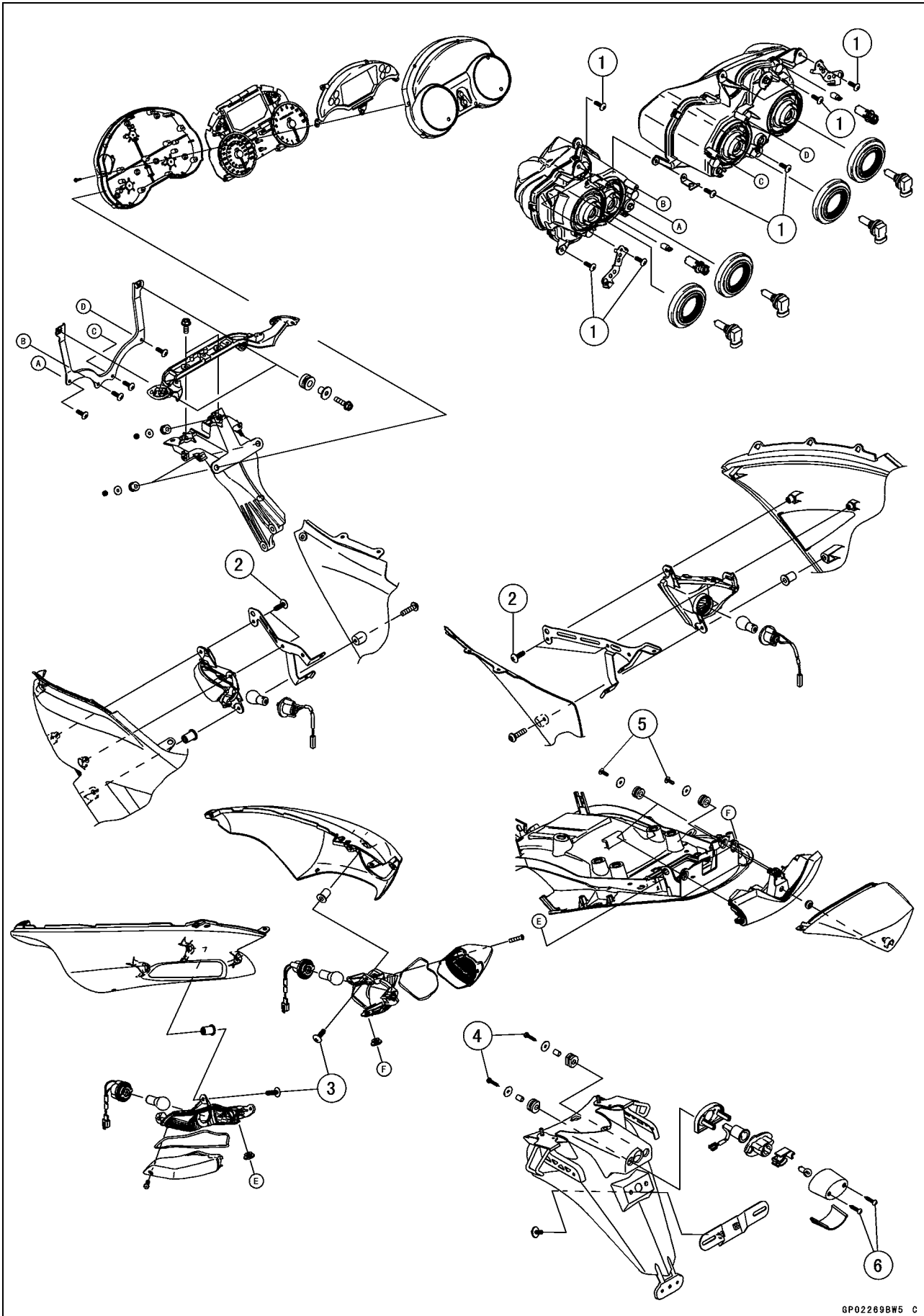

Exploded View

No.	Fastener	Torque			Remarks
		N·m	kgf·m	ft·lb	
1	Headlight Mounting Screws	1.2	0.12	11 in·lb	
2	Front Turn Signal Light Mounting Screws	1.2	0.12	11 in·lb	
3	Rear Turn Signal Light Mounting Screws	1.2	0.12	11 in·lb	
4	License Plate Light Mounting Screws	1.2	0.12	11 in·lb	
5	Tail/Brake Light Mounting Screws	1.2	0.12	11 in·lb	
6	License Plate Light Cover Mounting Screws	0.9	0.09	8 in·lb	

16-6 ELECTRICAL SYSTEM

Exploded View

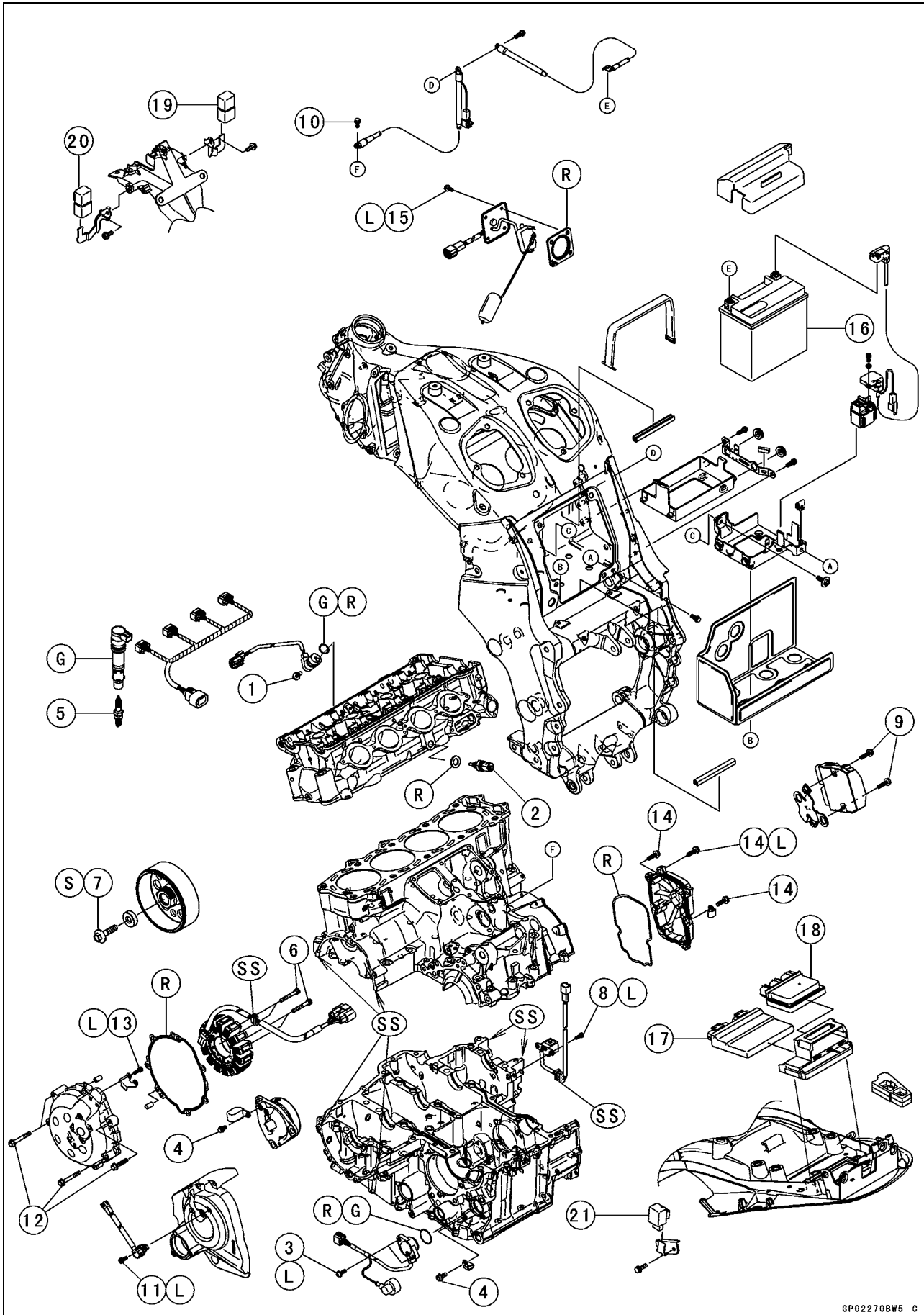

Exploded View

No.	Fastener	Torque			Remarks
		N·m	kgf·m	ft·lb	
1	Camshaft Position Sensor Bolt	9.8	1.0	87 in·lb	
2	Water Temperature Sensor	25	2.5	18	
3	Gear Position Switch Screws	2.9	0.30	26 in·lb	L
4	Gear Position Switch Lead Clamp Bolts	9.8	1.0	87 in·lb	
5	Spark Plugs	13	1.3	115 in·lb	
6	Stator Coil Bolts	12	1.2	106 in·lb	
7	Alternator Rotor Bolt (First)	69	7.0	51	S
	Alternator Rotor Bolt (Final)	110	11.2	81	S
8	Crankshaft Sensor Bolts	5.9	0.60	52 in·lb	L
9	Regulator/Rectifier Bolts	9.8	1.0	87 in·lb	
10	Engine Ground Terminal Bolt	9.8	1.0	87 in·lb	
11	Speed Sensor Bolt	3.9	0.40	35 in·lb	L
12	Alternator Cover Bolts	9.8	1.0	87 in·lb	
13	Alternator Lead Holding Plate Bolts	8.3	0.85	73 in·lb	L
14	Crankshaft Sensor Cover Bolts	9.8	1.0	87 in·lb	L (1)
15	Fuel Level Sensor Bolts	6.9	0.70	61 in·lb	L

16. Battery

17. ECU

18. Relay Box

19. Headlight Relay (Low)

20. Headlight Relay (Hi)

21. Turn Signal Relay

G: Apply grease.

L: Apply a non-permanent locking agent.

R: Replacement Parts

S: Follow the specified tighten sequence.

SS: Apply silicone sealant.

16-8 ELECTRICAL SYSTEM

Exploded View

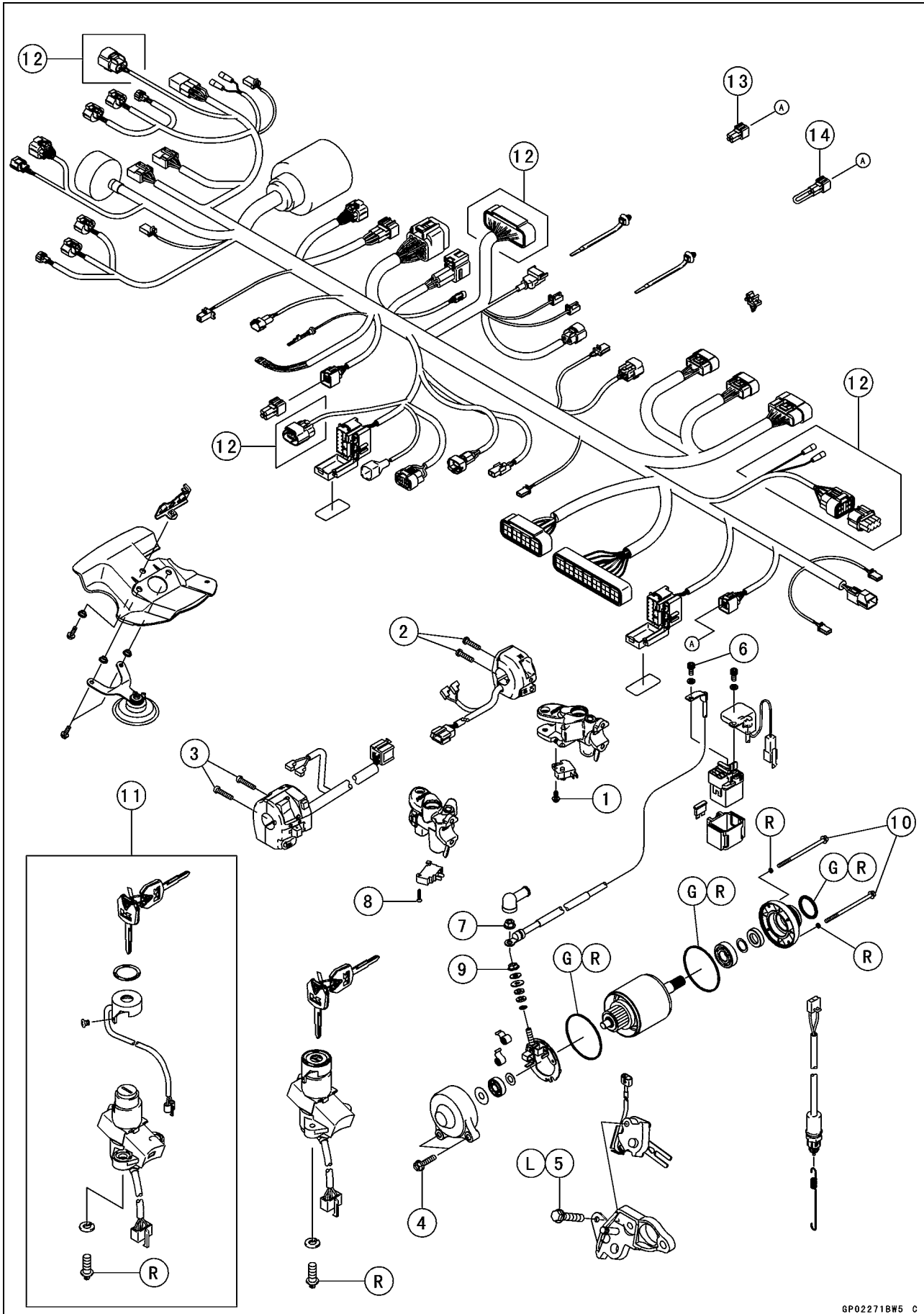

Exploded View

No.	Fastener	Torque			Remarks
		N·m	kgf·m	ft·lb	
1	Front Brake Light Switch Screw	1.2	0.12	11 in·lb	
2	Right Switch Housing Screws	3.5	0.36	31 in·lb	
3	Left Switch Housing Screws	3.5	0.36	31 in·lb	
4	Starter Motor Mounting Bolts	9.8	1.0	87 in·lb	
5	Sidestand Switch Bolt	8.8	0.90	78 in·lb	L
6	Starter Motor Cable Mounting Bolt	3.9	0.40	35 in·lb	
7	Starter Motor Cable Terminal Nut	5.9	0.60	52 in·lb	
8	Starter Lockout Switch Screw	0.7	0.07	6 in·lb	
9	Starter Motor Terminal Locknut	6.9	0.70	61 in·lb	
10	Starter Motor Through Bolts	3.4	0.35	30 in·lb	

- 11. Immobilizer Models
 - 12. ZX1400B Models
 - 13. Other than France and Malaysia Models
 - 14. France and Malaysia Models
- G: Apply grease.
 L: Apply a non-permanent locking agent.
 R: Replacement Parts

16-10 ELECTRICAL SYSTEM

Parts Location

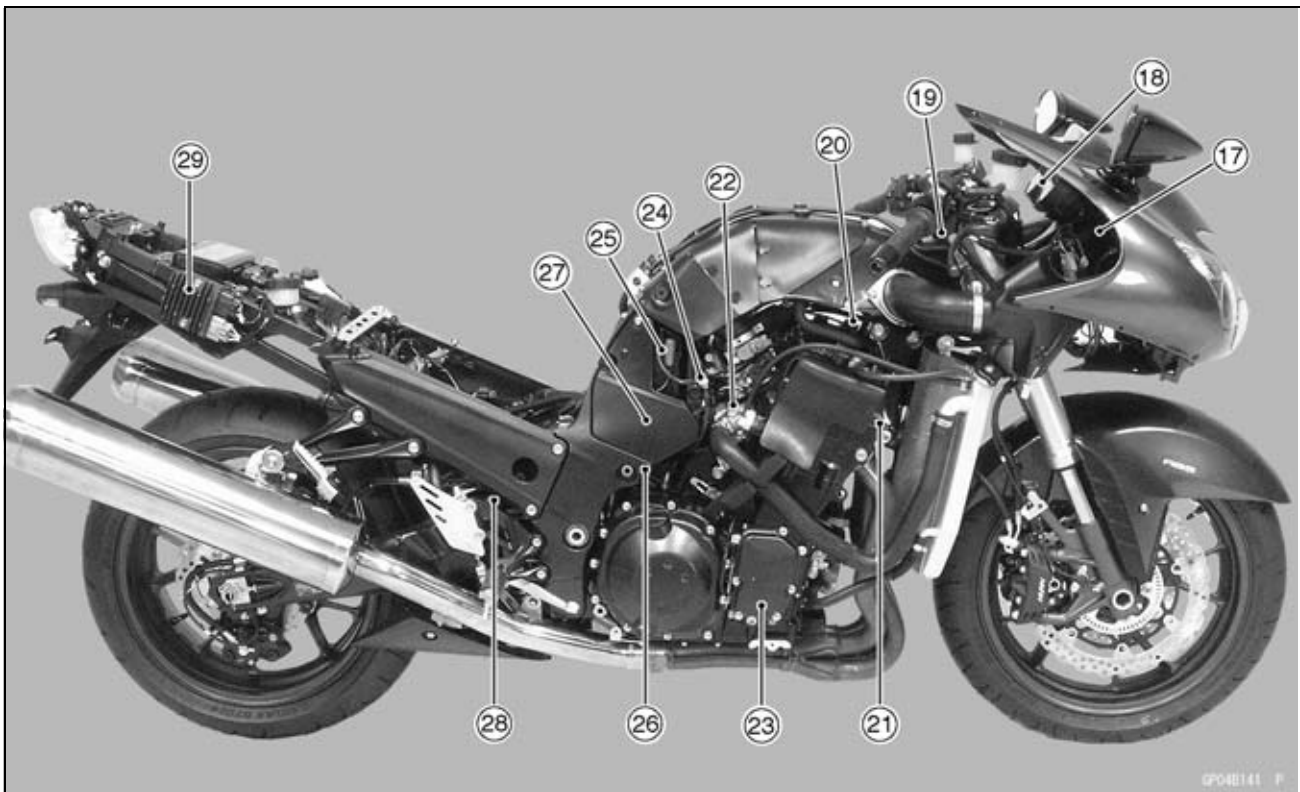
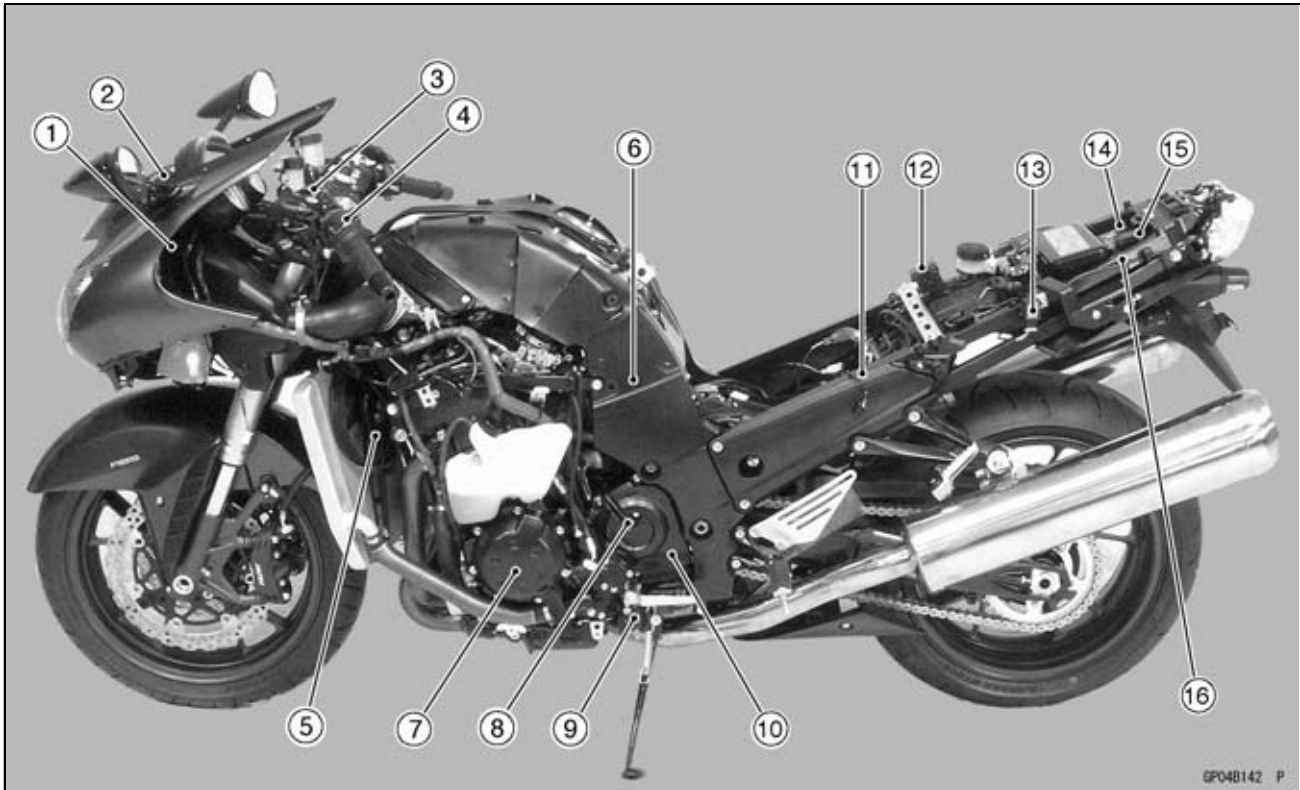

Parts Location

1. Headlight Relay (High)
2. Immobilizer Amplifier (Immobilizer Models)
3. Ignition Switch with Immobilizer Antenna (Immobilizer Models)
4. Starter Lockout Switch
5. Fan Motor
6. Starter Relay with Main Fuse 30 A
7. Alternator
8. Speed Sensor
9. Sidestand Switch
10. Gear Position Switch
11. Frame Ground 1
12. Fuse Box 1
13. Turn Signal Relay
14. Relay Box
15. Fuse Box 2 with ECU Fuse 15 A
16. ECU (Electric Control Unit)
17. Headlight Relay (Low)
18. Meter Unit
19. Front Brake Light Switch
20. Air Switching Valve
21. Camshaft Position Sensor
22. Water Temperature Sensor
23. Crankshaft Sensor
24. Frame Ground 2
25. Battery 12 V 14 Ah
26. Engine Ground
27. Starter Motor
28. Rear Brake Light Switch
29. Regulator/Rectifier

16-12 ELECTRICAL SYSTEM

Wiring Diagram (United States, Canada, New Zealand and Colombia)

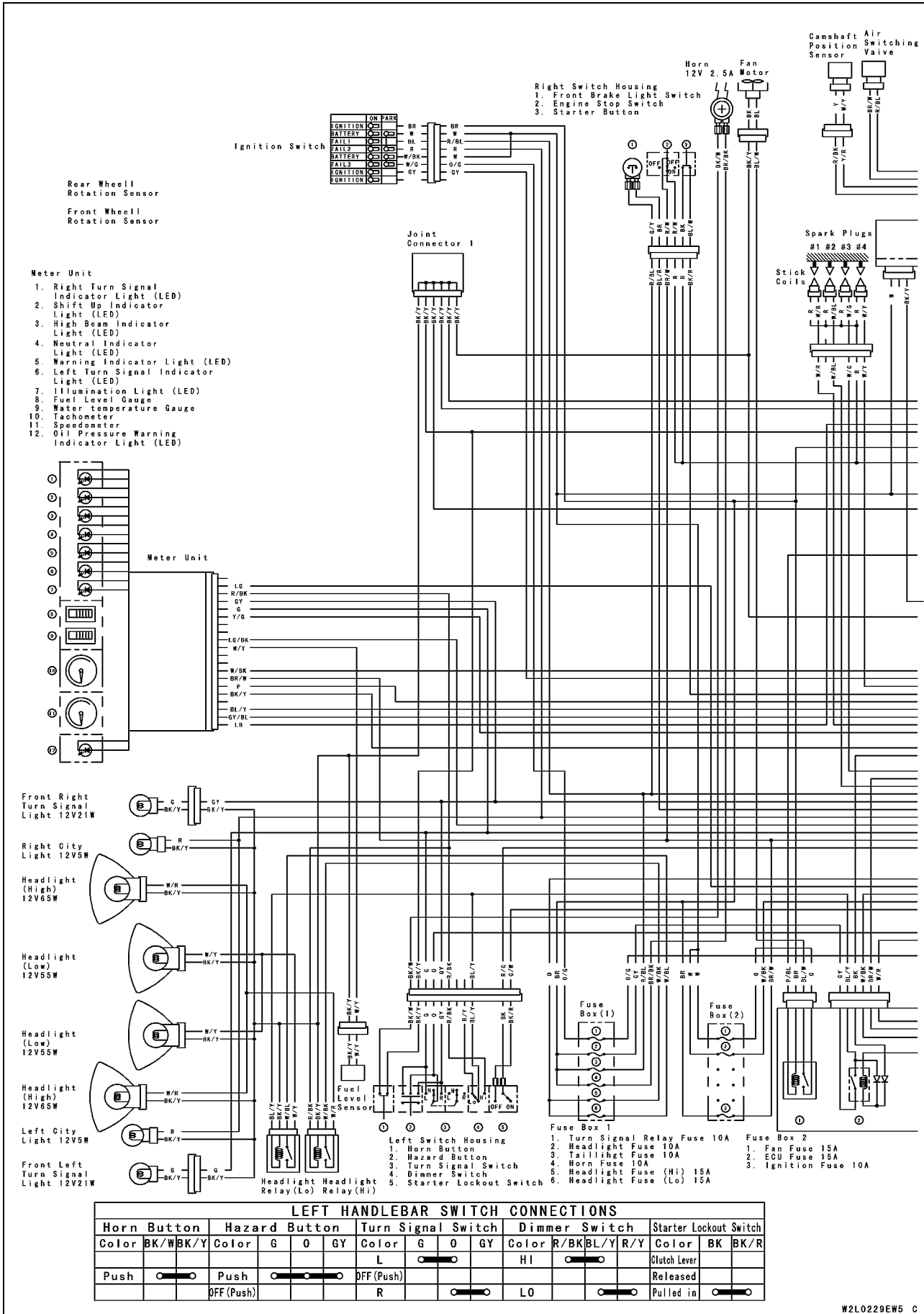

Wiring Diagram (United States, Canada, New Zealand and Colombia)

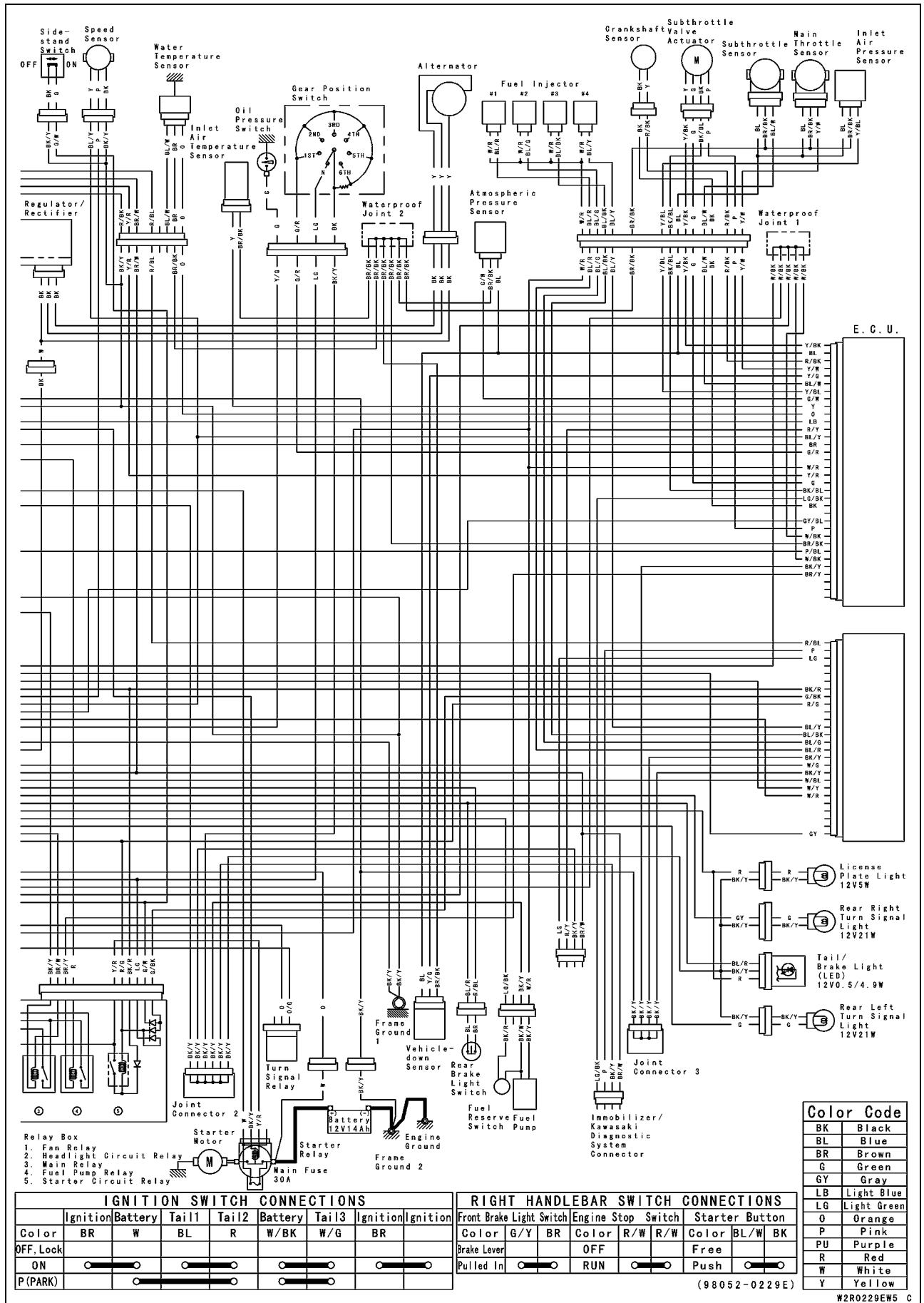

16-14 ELECTRICAL SYSTEM

Wiring Diagram (Other than United States, Canada, New Zealand and Colombia)

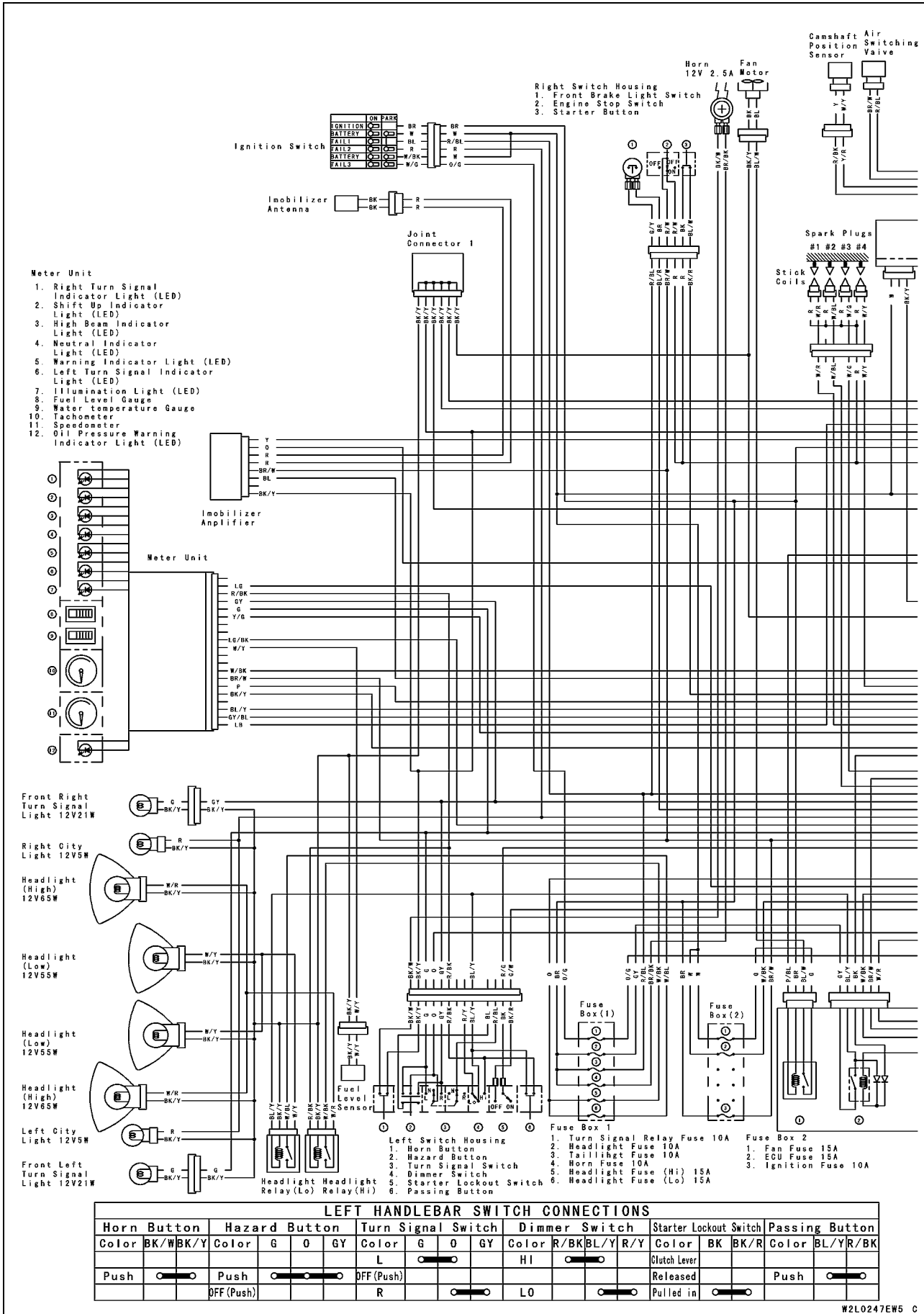

ELECTRICAL SYSTEM 16-15

Wiring Diagram (Other than United States, Canada, New Zealand and Colombia)

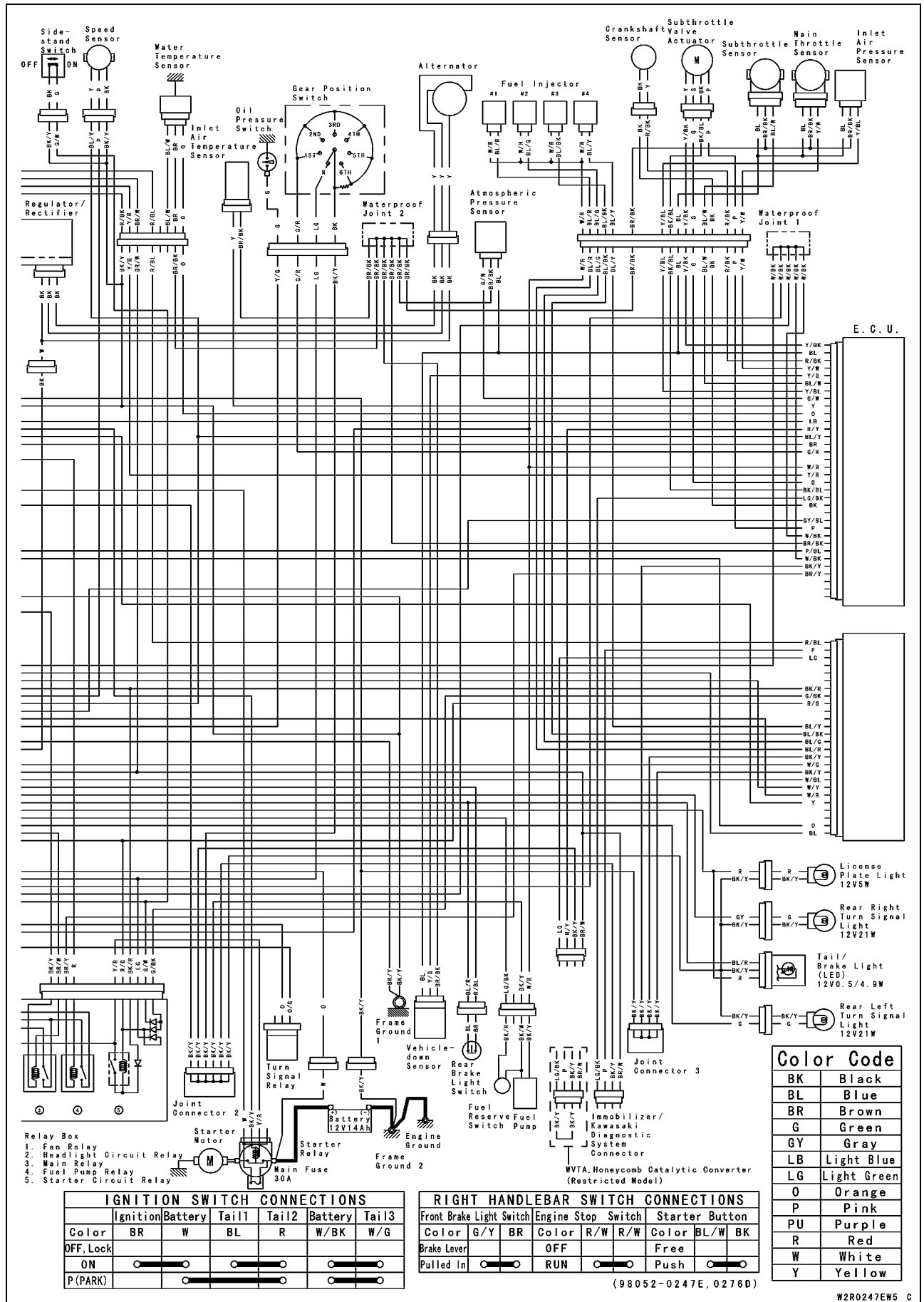

16-16 ELECTRICAL SYSTEM

Wiring Diagram (ZX1400B Models)

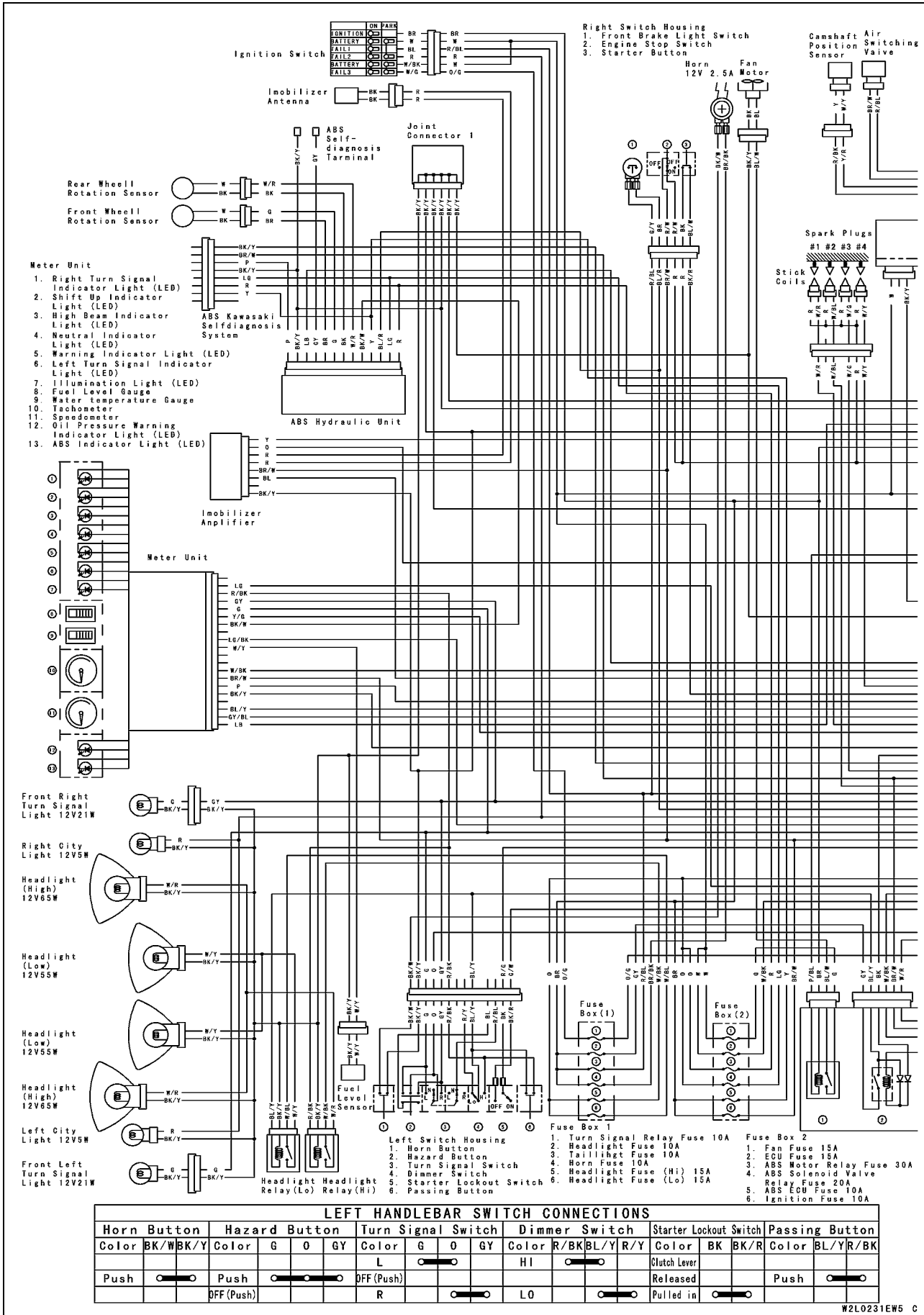

Wiring Diagram (ZX1400B Models)

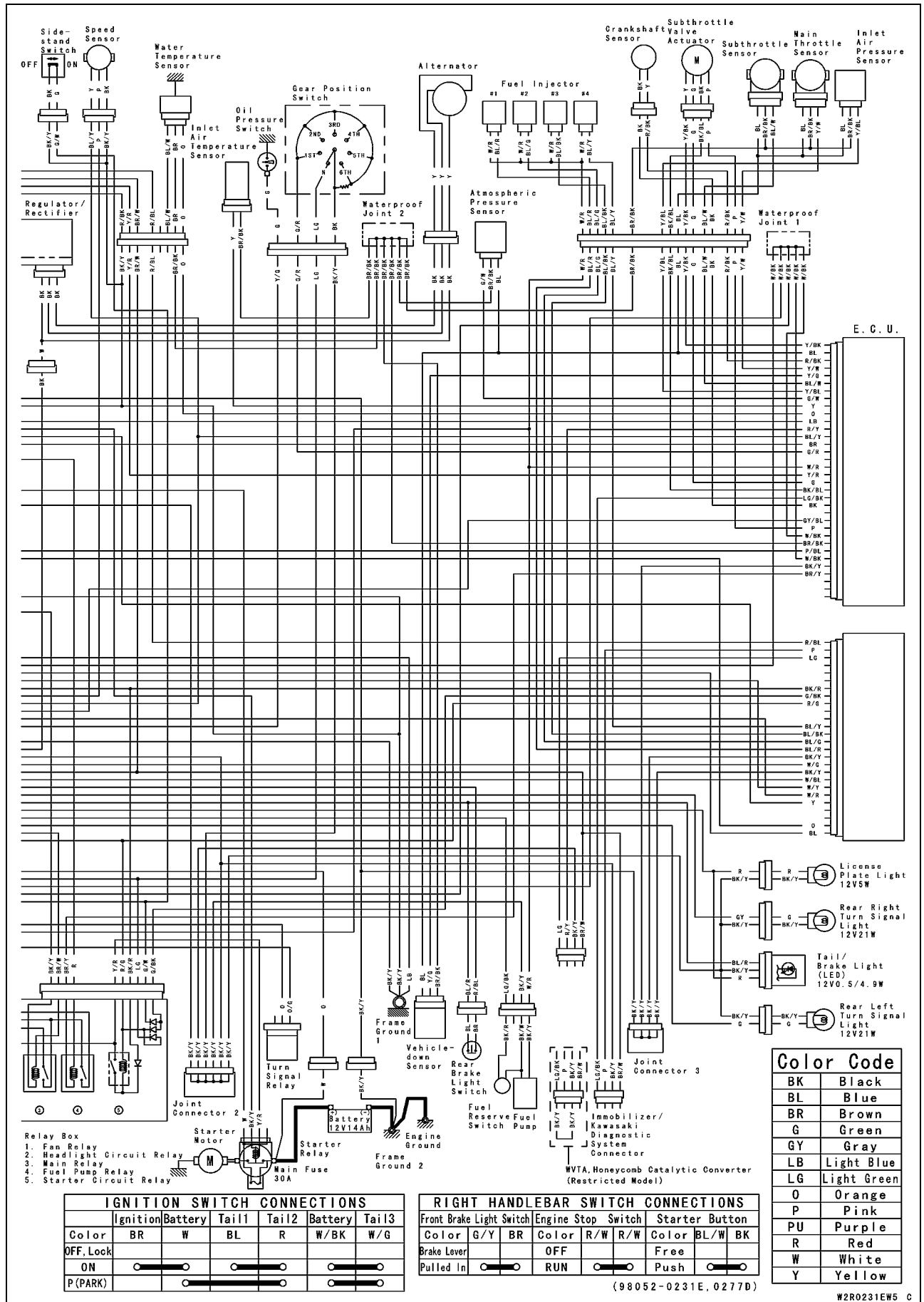

16-18 ELECTRICAL SYSTEM

Specifications

Item	Standard
Battery	
Type	Sealed battery
Model Name	FTZ14-BS
Capacity	12 V 14 Ah
Voltage	12.6 V or more
Charging System	
Type	Three-phase AC
Alternator Output Voltage	51 V or more @4 000 r/min (rpm)
Stator Coil Resistance	0.05 ~ 0.5 Ω
Charging Voltage (Regulator/Rectifier Output Voltage)	14.2 ~ 15.2 V
Ignition System	
Crankshaft Sensor Resistance	376 ~ 564 Ω
Crankshaft Sensor Peak Voltage	2.4 V or more
Camshaft Position Sensor Resistance	400 ~ 460 Ω
Camshaft Position Sensor Peak Voltage	2.8 V or more
Spark Plug Gap	0.8 ~ 0.9 mm (0.031 ~ 0.035 in.)
Stick Coil:	
Primary Winding Resistance	1.2 ~ 1.6 Ω
Secondary Winding Resistance	8.5 ~ 11.5 k Ω
Primary Peak Voltage	72 V or more
Electric Starter System	
Starter Motor:	
Brush Length	10 mm (0.39 in.), Service limit 5.0 mm (0.20 in.)
Commutator Diameter	28 mm (1.10 in.), Service limit 27 mm (1.06 in.)
Air Switching Valve	
Resistance	18 ~ 22 Ω at 20°C (68°F)
Meter, Gauge, Indicator Unit	
Can Communication Line Resistance (at Meter Unit)	122 ~ 126 Ω
Speed Sensor Supply Voltage	about 12 V
Switch and Sensor	
Rear Brake Light Switch Timing	ON after about 10 mm (0.39 in.) pedal travel
Engine Oil Pressure Switch Connections	When engine is stopped: ON When engine is running: OFF
Water Temperature Sensor Resistance	In the text
Fuel Level Sensor Resistance:	
Full Position	9 ~ 11 Ω
Empty Position	213 ~ 219 Ω

Special Tools and Sealant

**Hand Tester:
57001-1394**

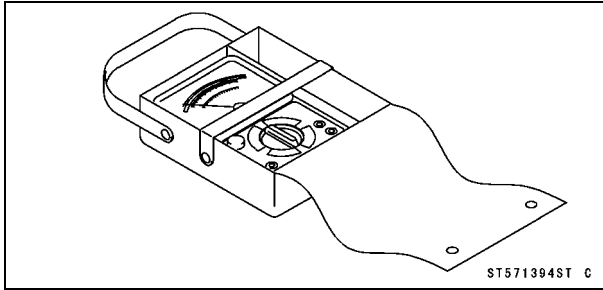

**Harness Adapter:
57001-1562**

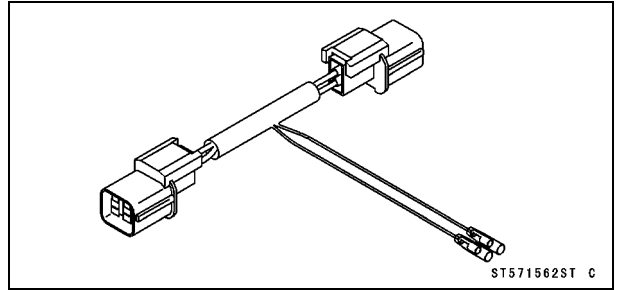

**Flywheel Puller Assembly, M38 × 1.5/M35 × 1.5:
57001-1405**

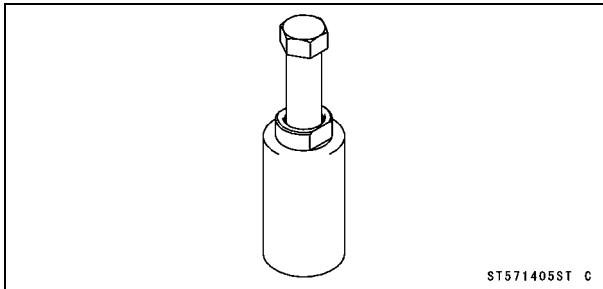

**Key Registration Unit:
57001-1582**

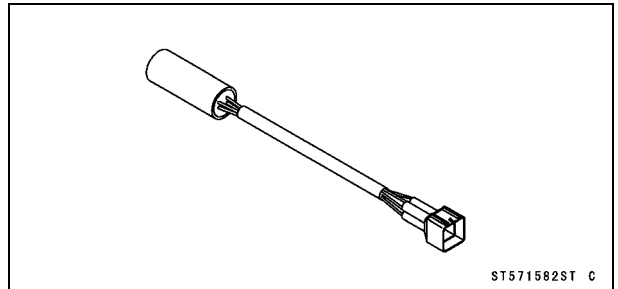

**Peak Voltage Adapter:
57001-1415**

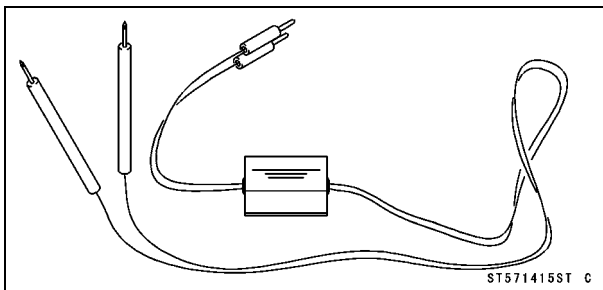

**Grip:
57001-1591**

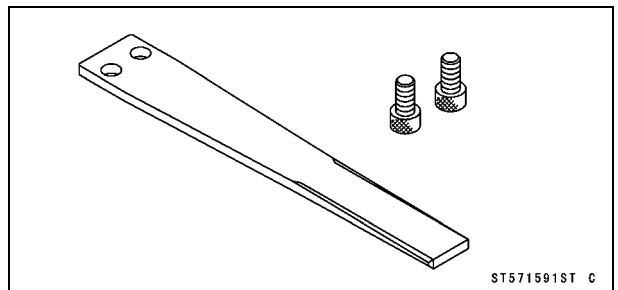

**Lead Wire - Peak Voltage Adapter:
57001-1449**

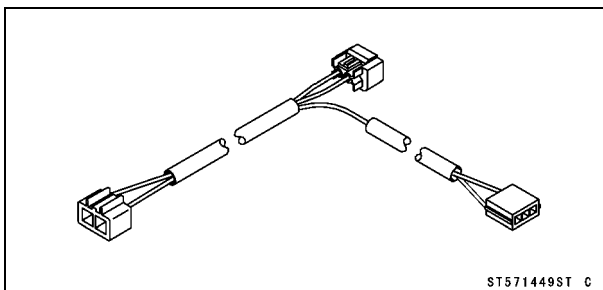

**Rotor Holder:
57001-1672**

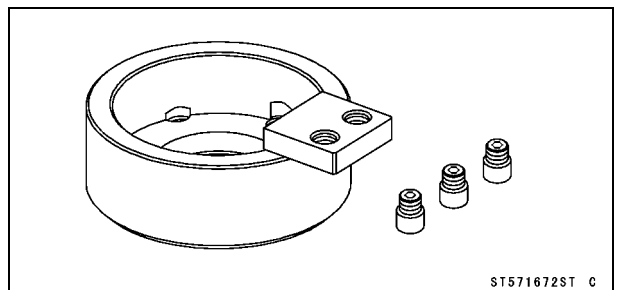

**Needle Adapter Set:
57001-1457**

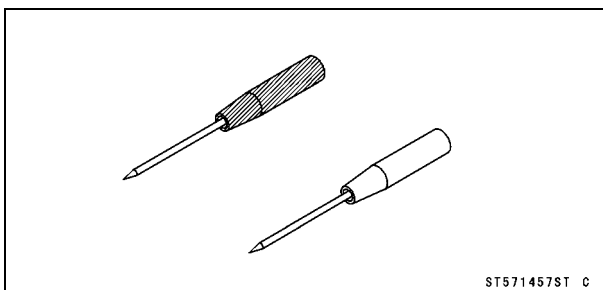

**Stopper:
57001-1679**

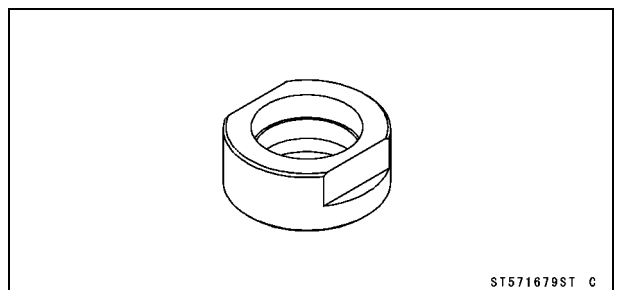

16-20 ELECTRICAL SYSTEM

Special Tools and Sealant

Kawasaki Bond (Silicone Sealant):

92104-0004

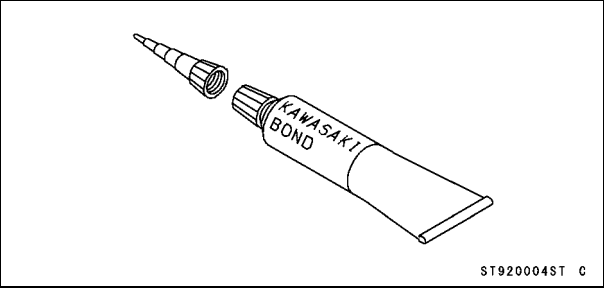

Precautions

There are a number of important precautions that are musts when servicing electrical systems. Learn and observe all the rules below.

- Do not reverse the battery cable connections. This will burn out the diodes on the electrical parts.
- Always check battery condition before condemning other parts of an electrical system. A fully charged battery is a must for conducting accurate electrical system tests.
- The electrical parts should never be struck sharply, as with a hammer, or allowed to fall on a hard surface. Such a shock to the parts can damage them.
- To prevent damage to electrical parts, do not disconnect the battery cables or any other electrical connections when the ignition switch is on, or while the engine is running.
- Because of the large amount of current, never keep the starter button pushed when the starter motor will not turn over, or the current may burn out the starter motor windings.
- Do not use a meter illumination bulb rated for other than voltage or wattage specified in the wiring diagram, as the meter or gauge panel could be warped by excessive heat radiated from the bulb.
- Take care not to short the cables that are directly connected to the battery positive (+) terminal to the chassis ground.
- Troubles may involve one or in some cases all items. Never replace a defective part without determining what CAUSED the failure. If the failure was caused by some other item or items, they must be repaired or replaced, or the new replacement will soon fail again.
- Make sure all connectors in the circuit are clean and tight, and examine wires for signs of burning, fraying, etc. Poor wires and bad connections will affect electrical system operation.
- Measure coil and winding resistance when the part is cold (at room temperature).
- Color Codes:

BK: Black	G: Green	P: Pink
BL: Blue	GY: Gray	PU: Purple
BR: Brown	LB: Light Blue	R: Red
CH: Chocolate	LG: Light Green	W: White
DG: Dark Green	O: Orange	Y: Yellow

16-22 ELECTRICAL SYSTEM

Electrical Wiring

Wiring Inspection

- Visually inspect the wiring for signs of burning, fraying, etc.
- ★ If any wiring is poor, replace the damaged wiring.
- Pull each connector [A] apart and inspect it for corrosion, dirt, and damage.
- ★ If the connector is corroded or dirty, clean it carefully. If it is damaged, replace it.
- Check the wiring for continuity.
- Use the wiring diagram to find the ends of the lead which is suspected of being a problem.
- Connect the hand tester between the ends of the leads.

Special Tool - Hand Tester: 57001-1394

- Set the tester to the $\times 1 \Omega$ range, and read the tester.
- ★ If the tester does not read 0Ω , the lead is defective. Replace the lead or the wiring harness [B] if necessary.

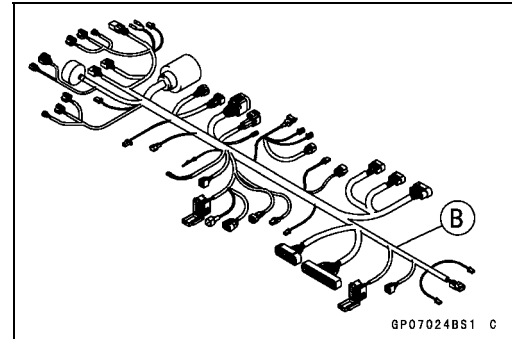
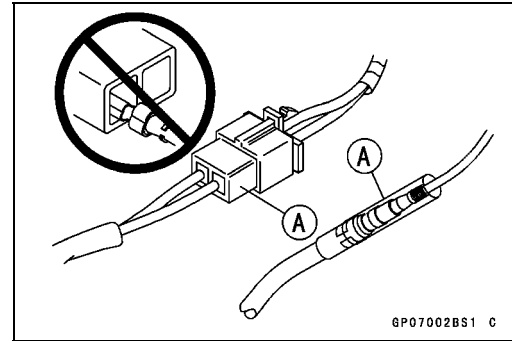

Battery

Battery Removal

- Turn off the ignition switch.
- Remove:
 - Right Fairing Cover (see Fairing Cover Removal in the Frame chapter)
 - Bolt [A]
 - Battery Compartment Cover [B]
- Clear the stoppers from the frame.

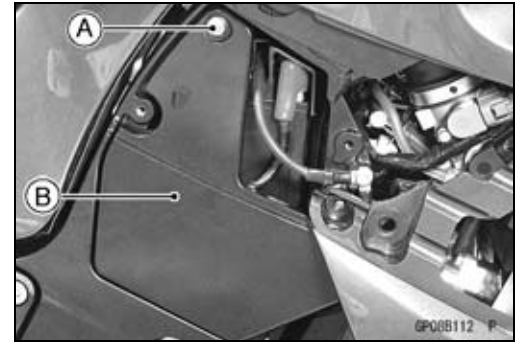

- Remove:
 - Bolt [A]
 - Bracket Bolts [B]
 - Bracket [C]
 - Connector [D] (Disconnect)

CAUTION

Be sure to disconnect the negative (-) cable first.
--

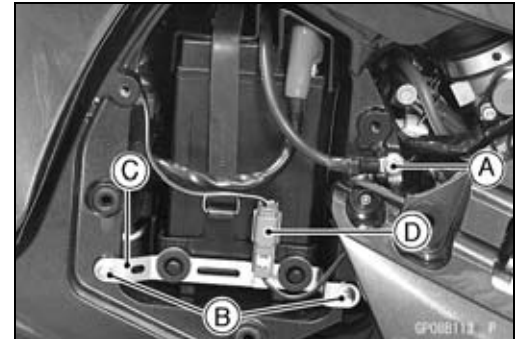

- Slightly pull out the battery tray [A].
- Unhook the band [B].
- Remove the battery cover [C].

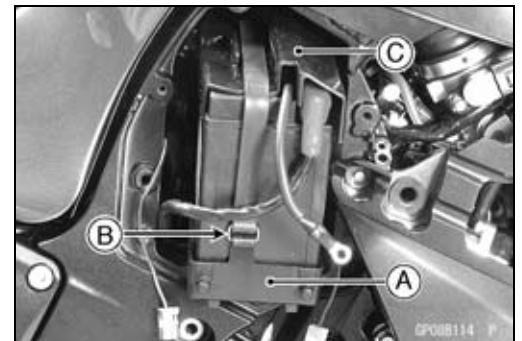

- Slide the red cap [A] out.
- Disconnect the positive (+) cable [B].
- Remove the battery tray with battery [C].

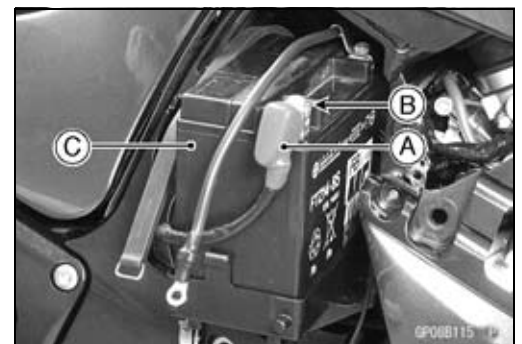

- Disconnect the negative (-) cable [A].
- Remove the battery [B] from the battery tray.



16-24 ELECTRICAL SYSTEM

Battery

Battery Installation

- Place the battery in the tray.
- Connect the negative (–) cable to the battery.
- Apply a light coat of grease on the terminals to prevent corrosion.
- Insert the battery tray along with the battery into the battery compartment.
- Connect the positive (+) cable to the battery.
- Cover the (+) terminal with its red cap [A].



- Install the battery cover on the battery, and hook the band.
- Be sure insert the battery tray along with the battery into the battery compartment.
- Put the holes [A] of the bracket to the projections [B] of the battery tray.
- Tighten the bracket bolts.
- Connect the connector.
- Connect the negative (–) cable to the frame.
- Put the projections of the battery compartment cover into the holes of the frame.
- Install:
 - Bolt
 - Right Fairing Cover (see Fairing Cover Installation in the Frame chapter)

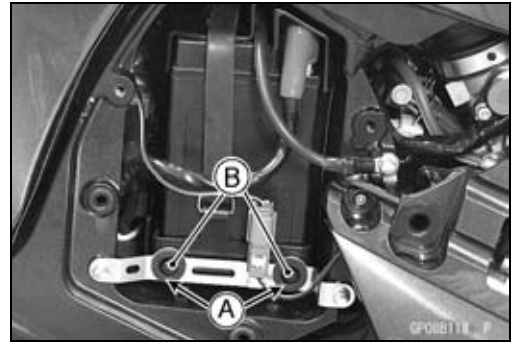

Battery Activation

Electrolyte Filling

- Make sure that the model name [A] of the electrolyte container matches the model name [B] of the battery. These names must be the same.

Battery Model Name for ZX1400A/B: FTZ14-BS

CAUTION

Be sure to use the electrolyte container with the same model name as the battery since the electrolyte volume and specific gravity vary with the battery type. This is to prevent overfilling of the electrolyte, shorting the battery life, and deterioration of the battery performance.

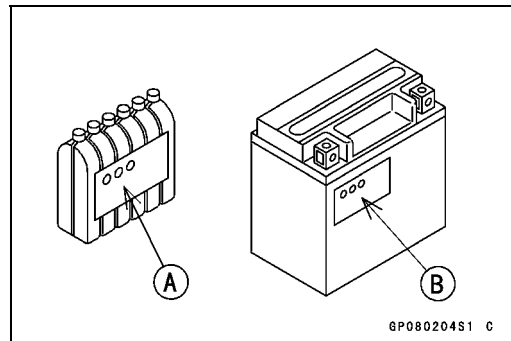

CAUTION

Do not remove the aluminum sealing sheet [A] from the filler ports [B] until just prior to use. Be sure to use the dedicated electrolyte container for correct electrolyte volume.

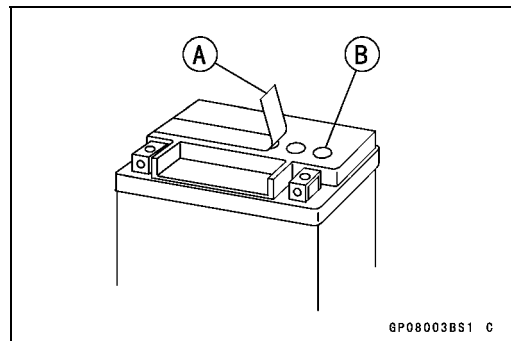

- Place the battery on a level surface.
- Check to see that the sealing sheet has no peeling, tears, or holes in it.
- Remove the sealing sheet.

NOTE

○The battery is vacuum sealed. If the sealing sheet has leaked air into the battery, it may require a longer initial charge.

Battery

- Remove the electrolyte container from the vinyl bag.
- Detach the strip of caps [A] from the container and set aside, these will be used later to seal the battery.

NOTE

○Do not pierce or otherwise open the sealed cells [B] of the electrolyte container. Do not attempt to separate individual cells.

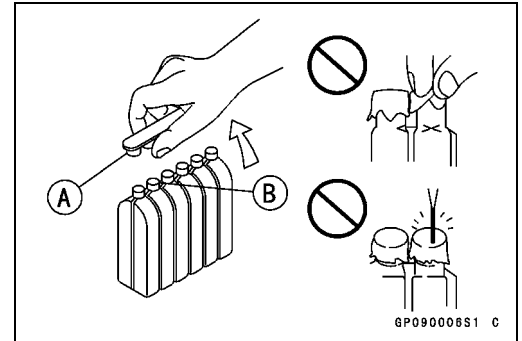

- Place the electrolyte container upside down with the six sealed cells into the filler ports of the battery. Hold the container level, push down to break the seals of all six cells. You will see air bubbles rising into each cell as the ports fill.

NOTE

○Do not tilt the electrolyte container

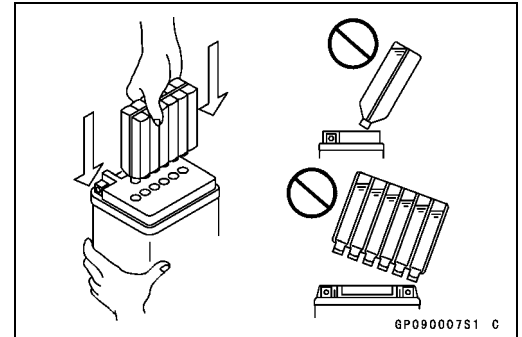

- Check the electrolyte flow.
- ★ If no air bubbles [A] are coming up from the filler ports, or if the container cells have not emptied completely, tap the container [B] a few times.
- Keep the container in place for **20** minutes or more. Don't remove the container from the battery until it's empty, the battery requires all the electrolyte from the container for proper operation.

CAUTION

Removal of the container before it is completely empty can shorten the service life of the battery. Do not remove the electrolyte container until it is completely empty and 20 minutes have elapsed.

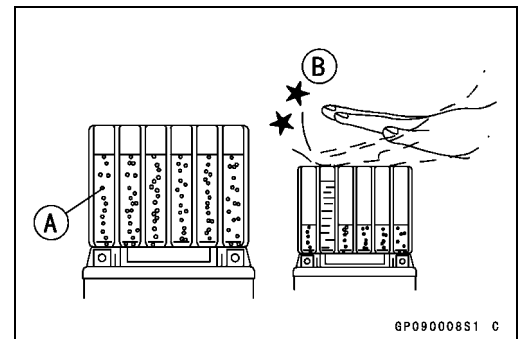

- Gently remove the container from the battery.
- Let the battery sit for **60** minutes prior to charging to allow the electrolyte to permeate into the plates for optimum performance.

NOTE

○Charging the battery immediately after filling can shorten service life. Let the battery sit for at least **60** minutes after filling.

16-26 ELECTRICAL SYSTEM

Battery

Initial Charge

- Place the strip [A] of caps loosely over the filler ports.
- Newly activated sealed batteries require an initial charge.

Standard Charge: 1.4 A × 5 ~ 10 hours

- ★ If using a recommended battery charger, follow the charger's instructions for newly activated sealed battery.

Kawasaki-recommended chargers:

Optimate III

Yuasa 1.5 Amp Automatic Charger

Battery Mate 150-9

- ★ If the above chargers are not available, use equivalent one.

NOTE

○ Charging rates will vary depending on how long the battery has been stored, temperature, and the type of charger used. Let battery sit 30 minutes after initial charge, then check voltage using a voltmeter. If it is not at least 12.6 volts, repeat charging cycle.

- After charging is completed, press down firmly with both hands to seat the strip of caps [A] into the battery (don't pound or hammer). When properly installed, the strip of the caps will be level with the top of the battery.

CAUTION

Once the strip of the caps is installed onto the battery, never remove the caps, nor add water or electrolyte to the battery.

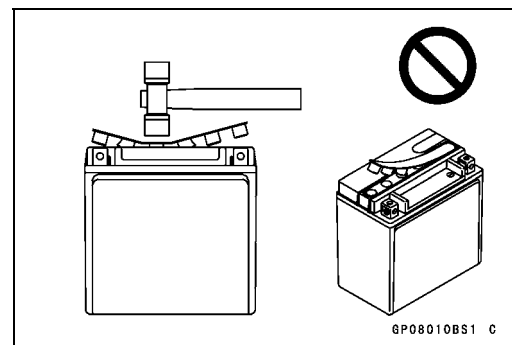
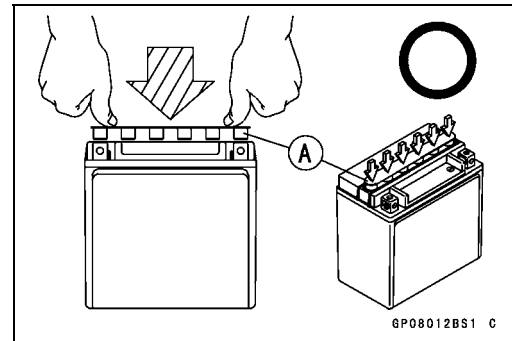
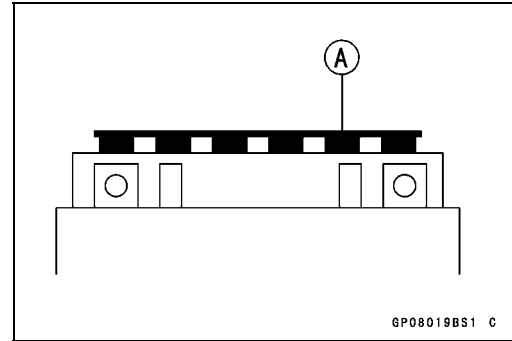

NOTE

○ To ensure maximum battery life and customer satisfaction, it is recommended the battery be load tested at three times its amp-hour rating for 15 seconds. Re-check voltage and if less than 12.6 volts repeat the charging cycle and load test. If still below 12.6 volts the battery is defective.

Battery

Precautions

- 1) No need of topping-up

No topping-up is necessary in this battery until it ends its life under normal use. Forcibly prying off the seal cap to add water is very dangerous. Never do that.

- 2) Refreshing charge

If an engine will not start, a horn sounds weak, or lamps are dim, it indicates the battery has been discharged. Give refresh charge for 5 to 10 hours with charge current shown in the specification (see this chapter).

When a fast charge is inevitably required, do it following precisely the maximum charge current and time conditions indicated on the battery.

CAUTION

This battery is designed to sustain no unusual deterioration if refresh-charged according to the method specified above. However, the battery's performance may be reduced noticeably if charged under conditions other than given above. Never remove the seal cap during refresh charge.

If by chance an excessive amount of gas is generated due to overcharging, the relief valve releases the gas to keep the battery normal.

- 3) When you do not use the motorcycle for months:

Give a refresh charge before you store the motorcycle and store it with the negative cable removed. Give a refresh charge **once a month** during storage.

- 4) Battery life:

If the battery will not start the engine even after several refresh charges, the battery has exceeded its useful life. Replace it (Provided, however, the vehicle's starting system has no problem).

⚠ WARNING

Keep the battery away from sparks and open flames during charging, since the battery gives off an explosive gas mixture of hydrogen and oxygen. When using a battery charger, connect the battery to the charger before turning on the charger.

This procedure prevents sparks at the battery terminals which could ignite any battery gases.

No fire should be drawn near the battery, or no terminals should have the tightening loosened.

The electrolyte contains sulfuric acid. Be careful not to have it touch your skin or eyes. If touched, wash it off with liberal amount of water. Get medical attention if severe.

Interchange

A sealed battery can fully display its performance only when combined with a proper vehicle electric system. Therefore, replace a sealed battery only on a motorcycle which was originally equipped with a sealed battery.

Be careful, if a sealed battery is installed on a motorcycle which had an ordinary battery as original equipment, the sealed battery's life will be shortened.

Charging Condition Inspection

- Battery charging condition can be checked by measuring battery terminal voltage with a digital voltmeter [A].
- Remove:
 - Battery (see Battery Removal)
- Measure the battery terminal voltage.

NOTE

- Measure with a digital voltmeter which can be read one decimal place voltage.

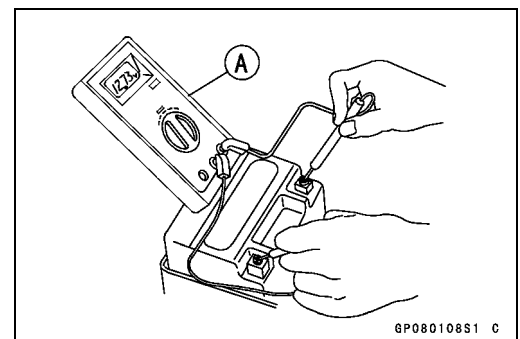

6P080108S1 C

16-28 ELECTRICAL SYSTEM

Battery

★ If the reading is 12.6 V or more, no refresh charge is required, however, if the read is below the specified, refresh charge is required.

Battery Terminal Voltage

Standard: 12.6 V or more

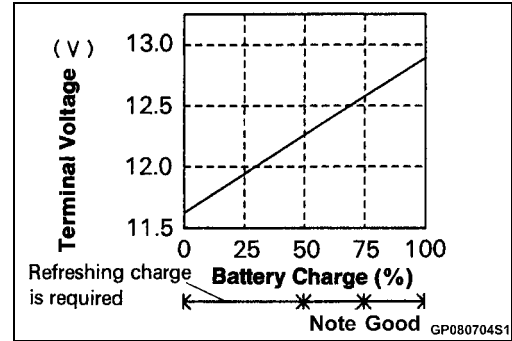

Refreshing Charge

- Remove the battery [A] (see Battery Removal).
- Do refresh charge by following method according to the battery terminal voltage.

⚠ WARNING

This battery is sealed type. Never remove sealing cap [B] even at charging. Never add water. Charge with current and time as stated below.

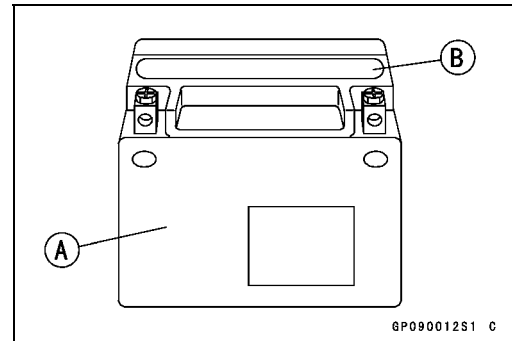

Terminal Voltage: 11.5 ~ less than 12.6 V
 Standard Charge 1.4 A × 5 ~ 10 h (see following chart)
 Quick Charge 7 A × 1 h

CAUTION

If possible, do not quick charge. If quick charge is done unavoidably, do standard charge later on.

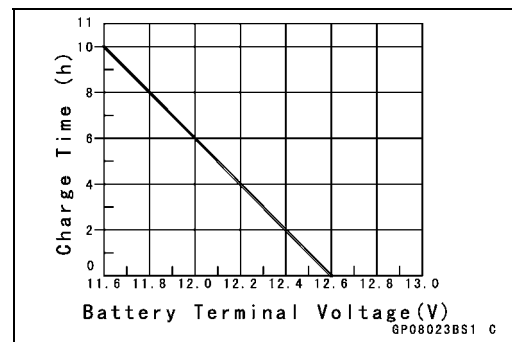

Terminal Voltage: less than 11.5 V
 Charging Method: 1.4 A × 20 h

NOTE

○ Increase the charging voltage to a maximum voltage of 25 V if the battery will not accept current initially. Charge for no more than 5 minutes at the increased voltage then check if the battery is drawing current. If the battery will accept current decrease the voltage and charge by the standard charging method described on the battery case. If the battery will not accept current after 5 minutes, replace the battery.

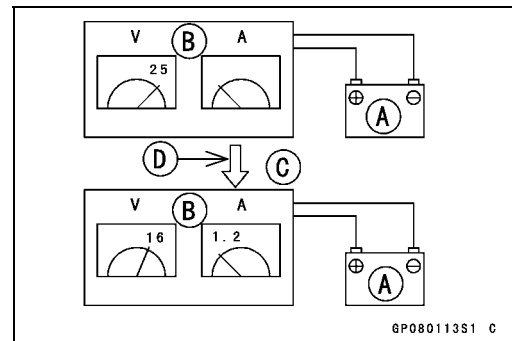

- Battery [A]
- Battery Charger [B]
- Standard Value [C]
- Current starts to flow [D]

- Determine the battery condition after refresh charge.
- Determine the condition of the battery left for 30 minutes after completion of the charge by measuring the terminal voltage according to the table below.

Criteria	Judgement
12.6 V or higher	Good
12.0 ~ lower than 12.6 V	Charge insufficient → Recharge
lower than 12.0 V	Unserviceable → Replace

Charging System

Alternator Cover Removal

- Remove:
 - Fuel Tank (see Fuel Tank Removal in the Fuel System (DFI) chapter)
 - Alternator Lead Connector [A]
 - Fuel Tank Bracket [B]

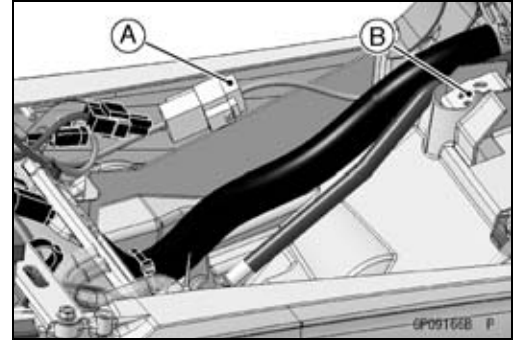

- Remove:
 - Bolts [A]
 - Cover [B]
- Pull the alternator lead out of between the engine and frame.

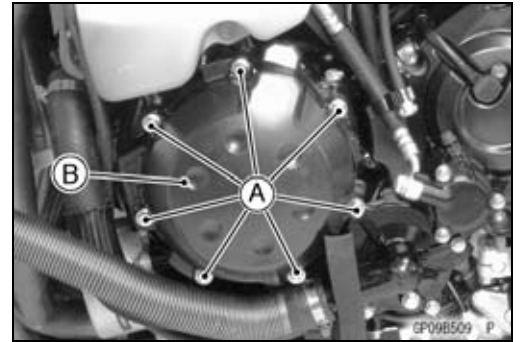

Alternator Cover Installation

- Apply silicone sealant to the alternator lead grommet and crankcase halves mating surface [A] on the front and rear sides of the cover mount.

Sealant - Kawasaki Bond (Silicone Sealant): 92104-0004

- Check that dowel pins [B] are in place on the crankcase.
- Install a new gasket and the alternator cover.
- Tighten:

Torque - Alternator Cover Bolts: 9.8 N·m (1.0 kgf·m, 87 in·lb)

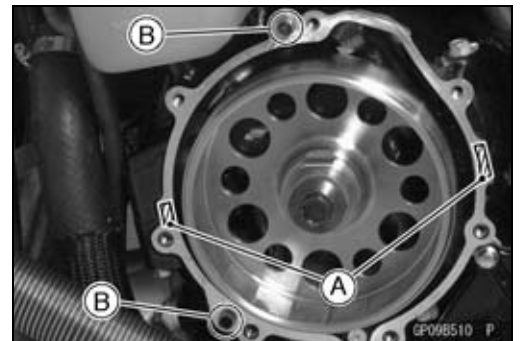

Stator Coil Removal

- Remove:
 - Alternator Cover (see Alternator Cover Removal)
 - Holding Plate Bolts [A] and Plate
 - Alternator Lead Grommet [B]
 - Stator Coil Bolts [C]
- Remove the stator coil [D] from the alternator cover.

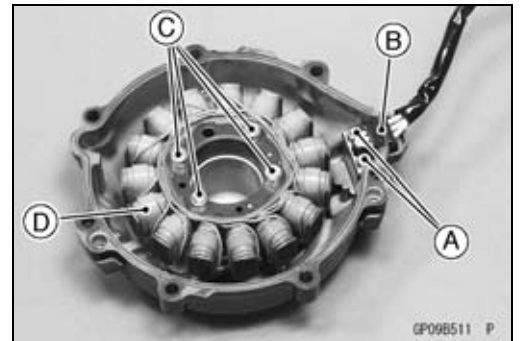

16-30 ELECTRICAL SYSTEM

Charging System

Stator Coil Installation

- Tighten the stator coil bolts to the specified torque.
Torque - Stator Coil Bolts: 12 N·m (1.2 kgf·m, 106 in·lb)
- Apply silicone sealant to the circumference of the alternator lead grommet, and fit the grommet into the notch of the cover securely.
Sealant - Kawasaki Bond (Silicone Sealant): 92104-0004
- Secure the alternator lead with a holding plate [A], and apply a non-permanent locking agent to the thread of the plate bolts and tighten them.
Torque - Alternator Lead Holding Plate Bolts: 8.3 N·m (0.85 kgf·m, 73 in·lb)
- Install the alternator cover (see Alternator Cover Installation).

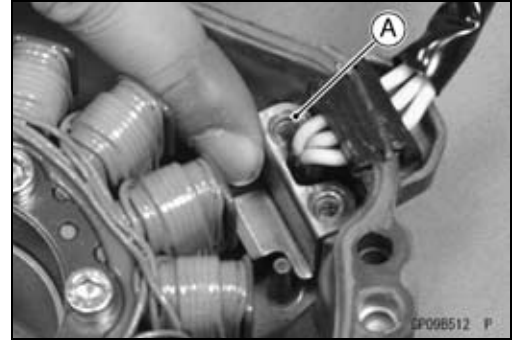

Alternator Rotor Removal

- Remove the alternator cover (see Alternator Cover Removal).
 - Clean off the oil from the outer circumference of the rotor.
 - Hold the alternator rotor steady with the rotor holder [A], and remove the rotor bolt [B] and washer.
- Special Tools - Grip [C]: 57001-1591**
Rotor Holder: 57001-1672
Stopper [D]: 57001-1679

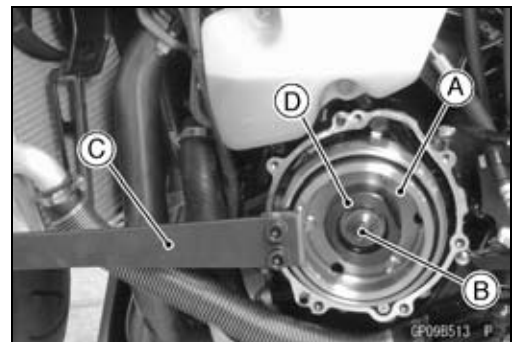

- Using the flywheel puller [A], remove the alternator rotor from the crankshaft.
Special Tool - Flywheel Puller, M38 × 1.5: 57001-1405



CAUTION

Do not attempt to strike the alternator rotor itself. Striking the rotor can cause the magnets to lose their magnetism.

Alternator Rotor Installation

- Using a cleaning fluid, clean off any oil or dirt on the following portions and dry them with a clean cloth.
Crankshaft Tapered Portion [A]
Alternator Rotor Tapered Portion [B]
- Install the alternator rotor.

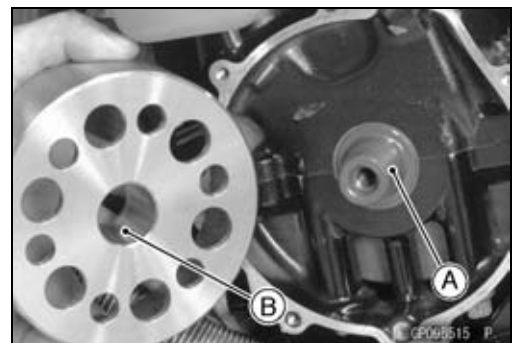

Charging System

- Using a cleaning fluid, clean off any oil or dirt on the washer [A] and dry it with a clean cloth.
- Install the washer so that its chamfer side [B] faces the rotor bolt [C].

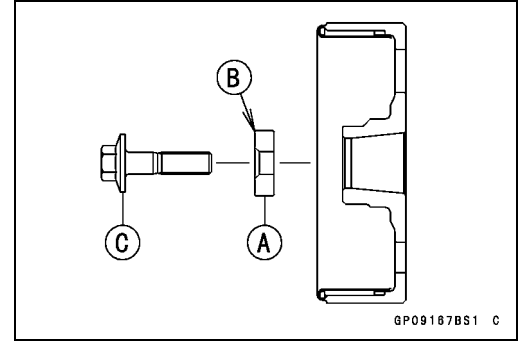

NOTE

○ Confirm the alternator rotor fit or not to the crankshaft before tightening it with specified torque.

- Install the rotor bolt [B] and tighten it with 69 N·m (7.0 kgf·m, 51 ft·lb) of torque.

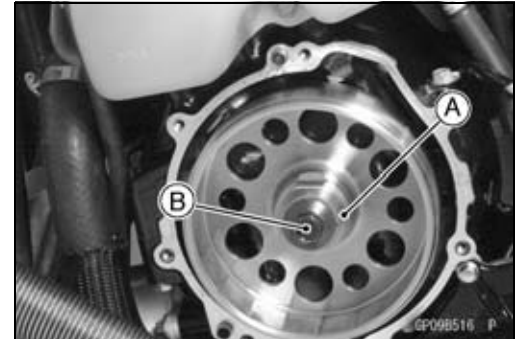

- Remove the rotor bolt and washer.
- Check the tightening torque with flywheel puller [A].
- ★ If the rotor is not pulled out with 20 N·m (2.0 kgf·m, 15 ft·lb) of drawing torque, it is installed correctly.
- ★ If the rotor is pulled out with under 20 N·m (2.0 kgf·m, 15 ft·lb) of drawing torque, clean off any oil dirt or flaw of the crankshaft and rotor tapered portion, and dry them with a clean cloth. Then, confirm that it is not pulled out with above torque.

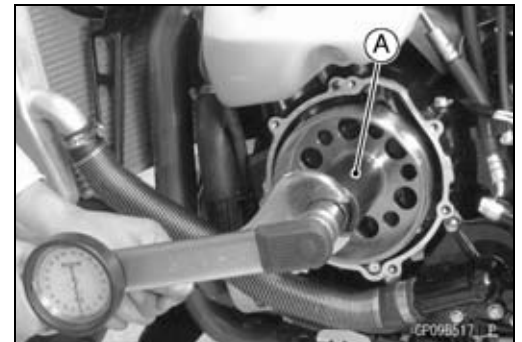

- Install the rotor bolt and washer.
- Tighten the alternator rotor bolt [A] while holding the alternator rotor steadily with the holder [B].

Special Tools - Grip [C]: 57001-1591

Rotor Holder: 57001-1672

Stopper [D]: 57001-1679

Torque - Alternator Rotor Bolt: 110 N·m (11.2 kgf·m, 81 ft·lb)

- Install the alternator cover (see Alternator Cover Installation).

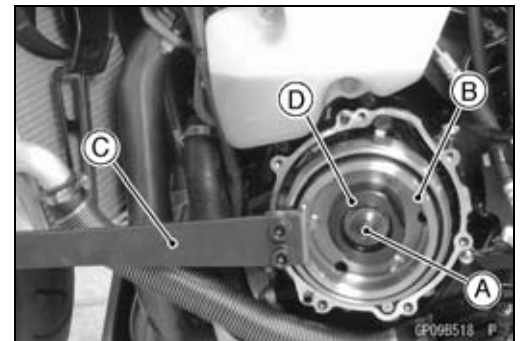

Alternator Inspection

There are three types of alternator failures: short, open (wire burned out), or loss in rotor magnetism. A short or open in one of the coil wires will result in either a low output, or no output at all. A loss in rotor magnetism, which may be caused by dropping or hitting the alternator, by leaving it near an electromagnetic field, or just by aging, will result in low output.

16-32 ELECTRICAL SYSTEM

Charging System

- To check the alternator output voltage, do the following procedures.
- Turn off the ignition switch.
- Remove the right seat cover (see Seat Cover Removal in the Frame chapter).
- Disconnect the alternator lead connector [A].
- Connect the hand tester as shown in the table 1.

Special Tool - Hand Tester: 57001-1394

- Start the engine.
- Run it at the rpm given in the table 1.
- Note the voltage readings (total 3 measurements).

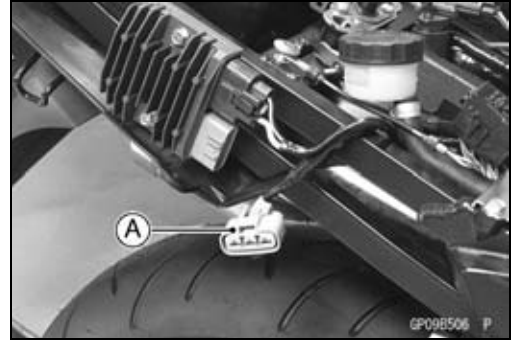

Table 1 Alternator Output Voltage

Tester Range	Connections		Reading @4 000 rpm
	Tester (+) to	Tester (-) to	
250 V AC	One Black Lead	Another Black Lead	51 V or more

- ★ If the output voltage shows the value in the table, the alternator operates properly.
- ★ If the output voltage shows a much higher than the value in the table, the regulator/rectifier is damaged. A much lower reading than that given in the table indicates that the alternator is defective.

- Check the stator coil resistance as follows.
- Stop the engine.
- Connect the commercially available tester as shown in the table 2.
- Note the readings (total 3 measurement).

Table 2 Stator Coil Resistance at 20°C (68°F)

Tester Range	Connections		Reading
	Tester (+) to	Tester (-) to	
$\times 1 \Omega$	One Black Lead	Another Black Lead	0.05 ~ 0.5 Ω

- ★ If there is more resistance than shown in the table, or no tester reading (infinity) for any two leads, the stator has an open lead and must be replaced. Much less than this resistance means the stator is shorted, and must be replaced.
- Using the highest resistance range of the hand tester, measure the resistance between each of the black leads and chassis ground.
- ★ Any hand tester reading less than infinity (∞) indicates a short, necessitating stator replacement.
- ★ If the stator coils have normal resistance, but the voltage check showed the alternator to be defective; then the rotor magnets have probably weakened, and the rotor must be replaced.

Charging System

Regulator/Rectifier Inspection

- Remove:
 - Right Seat Cover (see Seat Cover Removal in the Frame chapter)
 - Connectors [A]
 - Regulator/Rectifier Bolts [B]
 - Regulator/Rectifier [C]

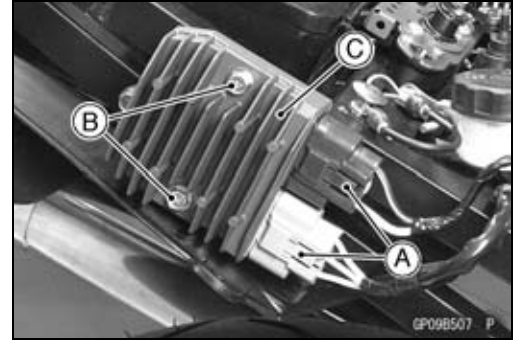

- Set the hand tester to the $\times 1 \text{ k}\Omega$ range and make the measurements shown in the table.

Special Tool - Hand Tester: 57001-1394

- Connect the hand tester to the regulator rectifier.
- ★ If the tester readings are not as specified, replace the regulator/rectifier.

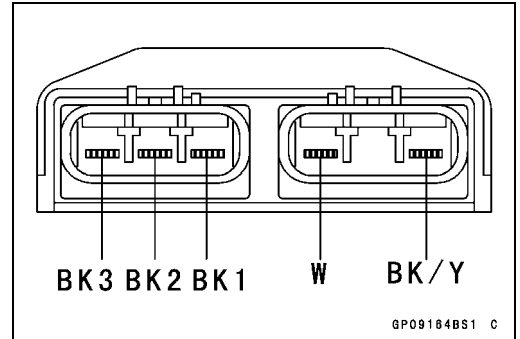

CAUTION

Use only Kawasaki Hand Tester 57001-1394 for this test. A tester other than the Kawasaki Hand Tester may show different readings. If a megger or a meter with a large capacity battery is used, the regulator/rectifier will be damaged.

Regulator/Rectifier Resistance (Unit: $\text{k}\Omega$)

		Tester (+) Lead Connection				
		W	BK1	BK2	BK3	BK/Y
(-)*	W	-	20 ~ 300	20 ~ 300	20 ~ 200	20 ~ 750
	BK1	0 ~ 5	-	20 ~ 300	20 ~ 200	20 ~ 750
	BK2	0 ~ 5	20 ~ 300	-	20 ~ 200	20 ~ 750
	BK3	0 ~ 5	20 ~ 300	20 ~ 300	-	20 ~ 750
	BK/Y	5 ~ 20	5 ~ 20	5 ~ 20	5 ~ 20	-

(-)*: Tester (-) Lead Connection

- Install the regulator/rectifier.
- Torque - Regulator/Rectifier Bolts: 9.8 N·m (1.0 kgf·m, 87 in·lb)**

16-34 ELECTRICAL SYSTEM

Charging System

Charging Voltage Inspection

- Check the battery condition (see Charging Condition Inspection).
- Warm up the engine to obtain actual alternator operating conditions.
- Remove the right fairing cover (see Fairing Cover Removal in the Frame chapter).
- Check that the ignition switch is turned off, and connect the hand tester [A] to the battery (+) terminal and ground.

Special Tool - Hand Tester: 57001-1394

- Start the engine, and note the voltage readings at various engine speeds with the headlight turned on and then turned off (To turn off the headlight, disconnect the headlight connector on the headlight unit.). The readings should show nearly battery voltage when the engine speed is low, and, as the engine speed rises, the readings should also rise. But they must be kept under the specified voltage.



Charging Voltage

Tester Range	Connections		Reading
	Tester (+) to	Tester (-) to	
25 V DC	Battery (+)	Ground	14.2 ~ 15.2 V

- Turn off the ignition switch to stop the engine, and disconnect the hand tester.
- ★ If the charging voltage is kept between the values given in the table, the charging system is considered to be working normally.
- ★ If the charging voltage is much higher than the values specified in the table, the regulator/rectifier is defective or the regulator/rectifier leads are loose or open.
- ★ If the charging voltage does not rise as the engine speed increases, then the regulator/rectifier is defective or the alternator output is insufficient for the loads. Check the alternator and regulator/rectifier to determine which part is defective.

Charging System

Charging System Circuit

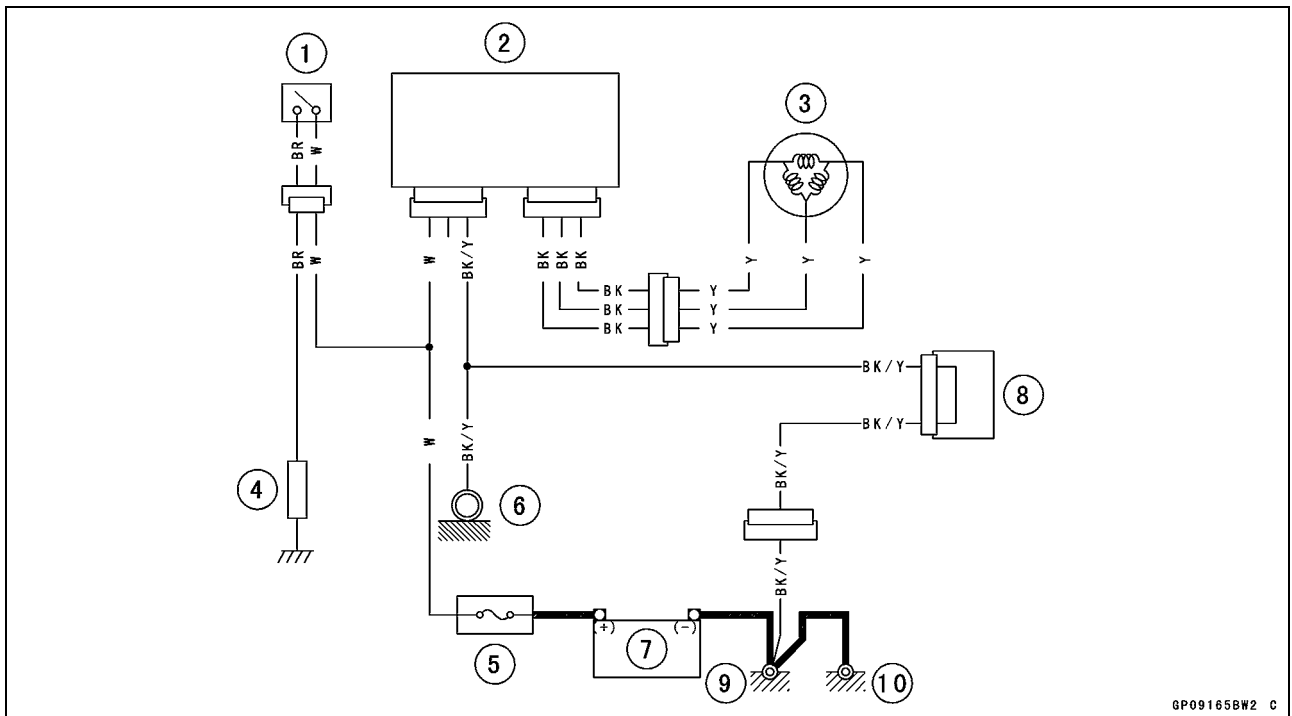

GP09165BW2 C

1. Ignition Switch
2. Regulator/Rectifier
3. Alternator
4. Load
5. Main Fuse 30 A
6. Frame Ground 1
7. Battery 12 V 14 Ah
8. Joint Connector 1
9. Frame Ground 2
10. Engine Ground

16-36 ELECTRICAL SYSTEM

Ignition System

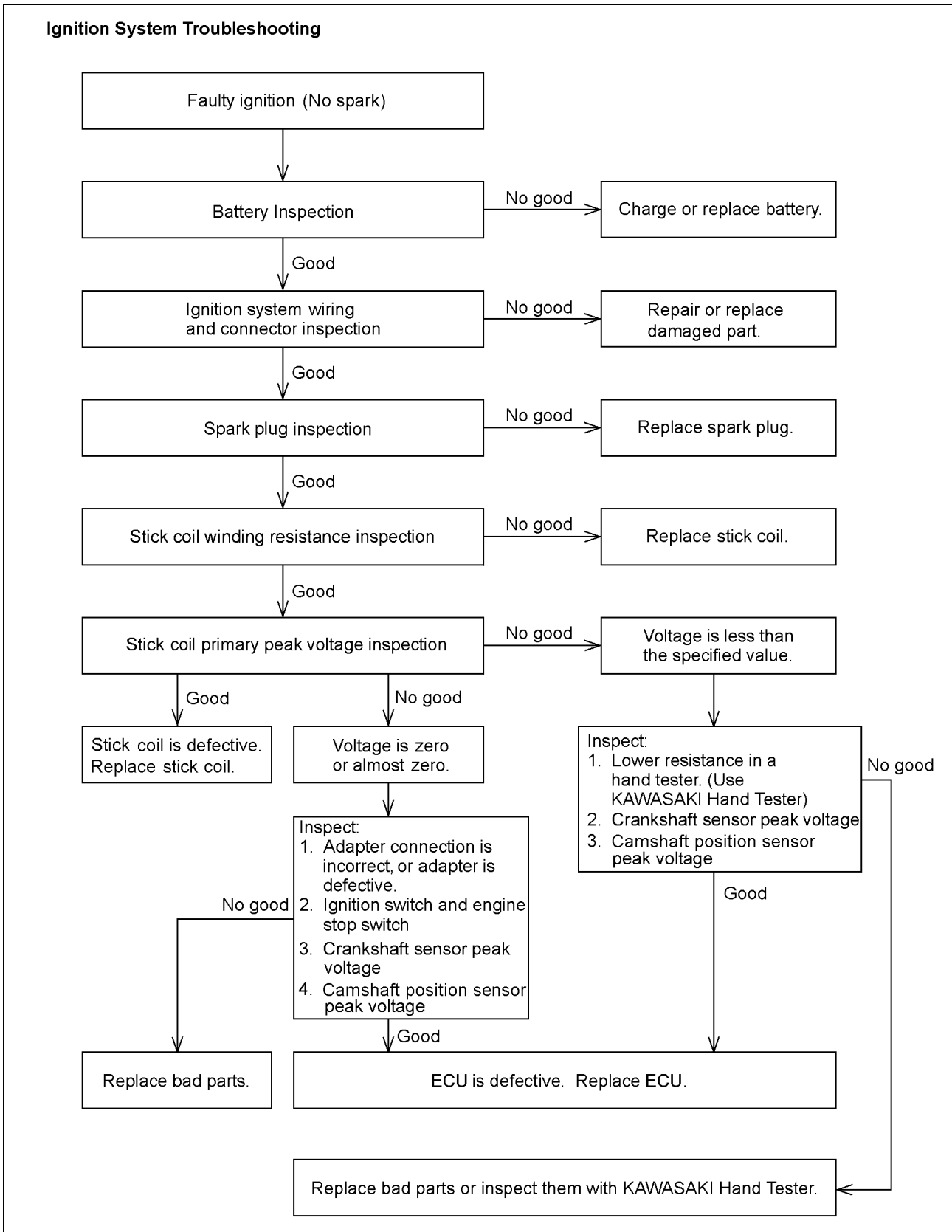

Ignition System

⚠ WARNING

The ignition system produces extremely high voltage. Do not touch the spark plugs or stick coils while the engine is running, or you could receive a severe electrical shock.

CAUTION

Do not disconnect the battery cables or any other electrical connections when the ignition switch is on, or while the engine is running. This is to prevent ECU damage.

Do not install the battery backwards. The negative side is grounded. This is to prevent damage to the ECU.

Crankshaft Sensor Removal

- Remove:
 - Right Lower Fairing (see Lower Fairing Removal in the Frame chapter)
 - Right Middle Fairing (see Middle Fairing Removal in the Frame chapter)
 - Crankshaft Sensor Lead Connector [A]

- Remove:
 - Crankshaft Sensor Cover Bolts
 - Crankshaft Sensor Cover
 - Crankshaft Sensor Bolts [A]
 - Crankshaft Sensor [B]

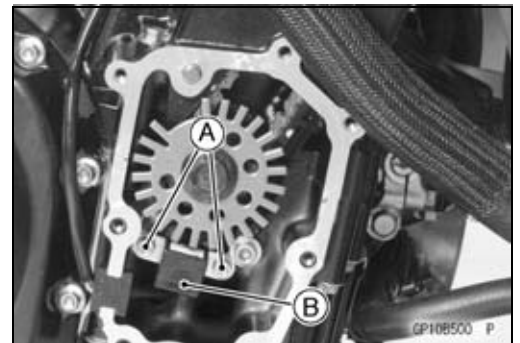
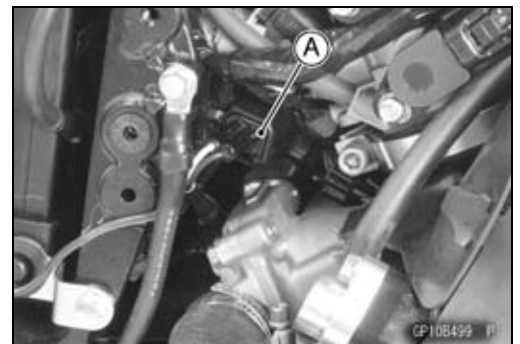

16-38 ELECTRICAL SYSTEM

Ignition System

Crankshaft Sensor Installation

- Apply a non-permanent locking agent to the threads of the crankshaft sensor bolts [A], and tighten it.

Torque - Crankshaft Sensor Bolts: 5.9 N·m (0.60 kgf·m, 52 in·lb)

- Apply silicone sealant to the circumference of the crankshaft sensor lead grommet [B], and fit the grommet into the notch of the crankcase securely.
- Apply silicone sealant to the mating surface [C] of crankcase halves.

Sealant - Kawasaki Bond (Silicone Sealant): 92104-0004

- Replace the O-ring [D] with a new one.
- Install the crankshaft sensor cover.
- Apply a non-permanent locking agent to only one crankshaft sensor cover bolt [E] shown in figure.
- Tighten the crankshaft sensor cover bolts.

Torque - Crankshaft Sensor Cover Bolts: 9.8 N·m (1.0 kgf·m, 87 in·lb)

- Route the crankshaft sensor lead correctly (see Cable, Wire, and Hose Routing section in the Appendix chapter).
- Install the removed parts (see appropriate chapters).

Crankshaft Sensor Inspection

- Remove the right fairing cover (see Fairing Cover Removal in the Frame chapter).
- Disconnect the crankshaft sensor lead connector (see Crankshaft Sensor Removal).
- Set the hand tester [A] to the $\times 100 \Omega$ range and connect it to the crankshaft sensor lead connector [B].

Special Tool - Hand Tester: 57001-1394

Crankshaft Sensor Resistance: 376 ~ 564 Ω

- ★ If there is more resistance than the specified value, the coil has an open lead and must be replaced. Much less than this resistance means the coil is shorted, and must be replaced.
- Using the highest resistance range of the tester, measure the resistance between the crankshaft sensor leads and chassis ground.
- ★ Any tester reading less than infinity (∞) indicates a short, necessitating replacement of the crankshaft sensor.

Crankshaft Sensor Peak Voltage Inspection

NOTE

- Be sure the battery is fully charged.
- Using the peak voltage adapter is a more reliable way to determine the condition of the crankshaft sensor than crankshaft sensor internal resistance measurements.

- Disconnect the crankshaft sensor lead connector (see Crankshaft Sensor Removal).

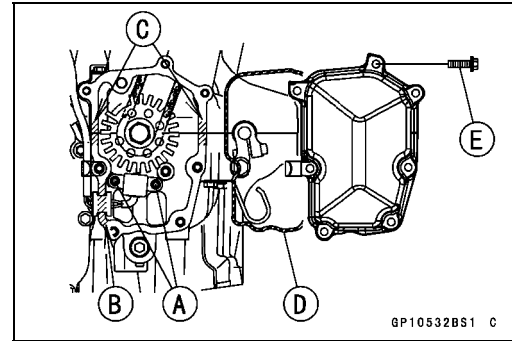

Ignition System

- Set the hand tester [A] to the × 25 V DC range, and connect the peak voltage adapter [B].

Special Tools - Hand Tester: 57001-1394

Peak Voltage Adapter: 57001-1415

Type: KEK-54-9-B

Connections:

Crankshaft Sensor Connector [C]		Adapter		Hand Tester
Black	←	Black	→	(-)
Yellow	←	Red	→	(+)

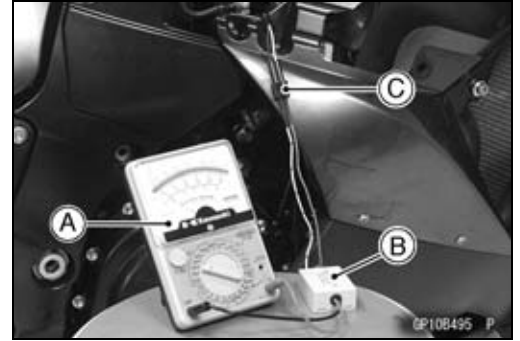

- Turn the ignition switch and engine stop switch ON.
- Pushing the starter button, turn the engine 4 ~ 5 seconds with the transmission gear in neutral to measure the crankshaft sensor peak voltage.
- Repeat the measurement 5 or more times.

Crankshaft Sensor Peak Voltage

Standard: 2.4 V or more

- ★ If the tester reading is not specified one, check the crankshaft sensor.

Stick Coil (Ignition Coil together with Spark Plug Cap) Removal

- Remove:
 - Middle Fairings (see Middle Fairing Removal in the Frame chapter)
- Disconnect the stick coil connectors [A].
- Pull the stick coils [B] off the spark plugs.

CAUTION

Do not pry the connector part of the coil while removing the coil.



Stick Coil (Ignition Coil together with Spark Plug Cap) Installation

- Apply grease to the stick coils.
- Insert the stick coils [A] as shown being careful of the coil heads directions.
- Align the lines [B] of the cylinder head cover and coil heads.

CAUTION

Do not tap the coil head while installing the coil.

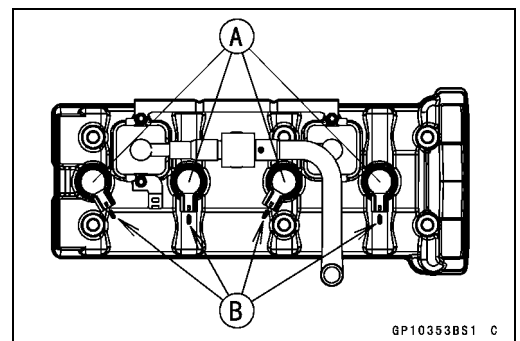

- Connect the stick coil connectors.
- Run the hoses and harness correctly (see Cable, Wire, and Hose Routing section in Appendix chapter).
- Install the removed parts (see appropriate chapters).

16-40 ELECTRICAL SYSTEM

Ignition System

Stick Coil (Ignition Coil together with Spark Plug Cap) Inspection

- Remove the stick coils (see Stick Coil (Ignition Coil together with Spark Plug Cap) Removal).
- Measure the primary winding resistance [A] as follows.
 - Connect the hand tester between the coil terminals.
 - Set the tester to the $\times 1 \Omega$ range, and read the tester.
- Measure the secondary winding resistance [B] as follows.
 - Connect the tester between the plug terminal and (-) coil terminal.
 - Set the tester to the $\times 1 \text{ k}\Omega$ range and read the tester.

Stick Coil Winding Resistance

Primary Windings: 1.2 ~ 1.6 Ω

Secondary Windings: 8.5 ~ 11.5 $\text{k}\Omega$

★ If the tester does not read as specified, replace the coil.

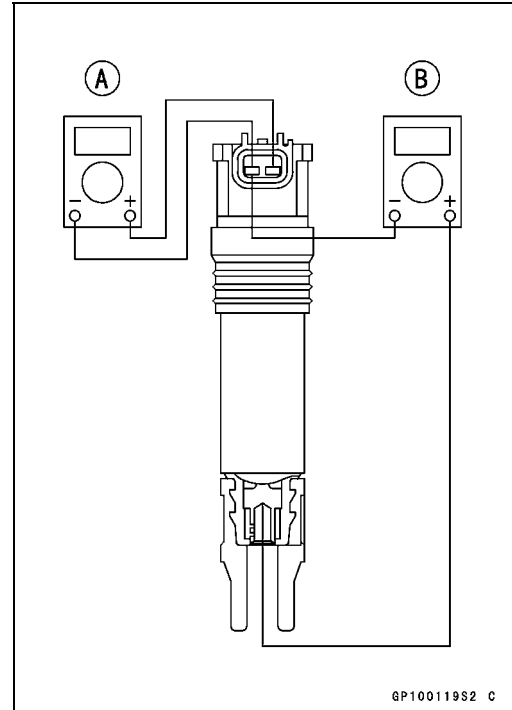

Stick Coil Primary Peak Voltage

NOTE

○ Be sure the battery is fully charged.

- Remove the stick coils (see Stick Coil (Ignition Coil together with Spark Plug Cap) Removal).
- Do not remove the spark plug.
- Measure the primary peak voltage as follows.
 - Install the new spark plug [A] into each stick coil [B], and ground them onto the engine.
 - Connect the peak voltage adapter [C] to the hand tester [D] which is set to the $\times 250 \text{ V DC}$ range.
 - Connect the adapter to the lead wire-peak voltage adapter [E] which is connected between the stick coil connector and stick coil.

ECU [F]

Battery [G]

Special Tools - Hand Tester: 57001-1394

Peak Voltage Adapter: 57001-1415

Type: KEK-54-9-B

Lead Wire-Peak Voltage Adapter: 57001-1449

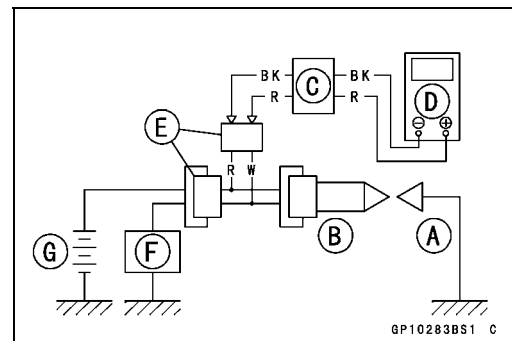
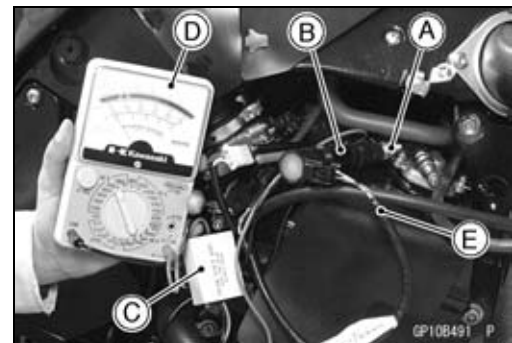

Primary Lead Connection

Adapter (R, +) to lead wire-peak voltage adapter (W)

Adapter (BK, -) to lead wire-peak voltage adapter (R)

Ignition System

⚠ WARNING

To avoid extremely high voltage shocks, do not touch the spark plugs or tester connections.

- Turn the ignition switch and engine stop switch ON.
- Pushing the starter button, turn the engine 4 ~ 5 seconds with the transmission in neutral to measure the primary peak voltage.
- Repeat the measurements 5 times for one stick coil.

Stick Coil Primary Peak Voltage

Standard: 72 V or more

- Repeat the test for the other stick coils.
- ★ If the reading is less than the specified value, check the following.
 - Stick Coils (see Stick Coil (Ignition Coil together with Spark Plug Cap) Inspection)
 - Crankshaft Sensor (see Crankshaft Sensor Inspection)
 - ECU (see ECU Power Supply Inspection in the Fuel System (DFI) chapter)

Spark Plug Removal

- Refer to the Spark Plug Replacement in the Periodic Maintenance chapter (see Spark Plug Replacement in the Periodic Maintenance chapter).

Spark Plug Installation

- Refer to the Spark Plug Replacement in the Periodic Maintenance chapter (see Spark Plug Replacement in the Periodic Maintenance chapter).

Spark Plug Condition Inspection

- Visually inspect the spark plugs.
- ★ If the spark plug center electrode [A] and/or side electrode [B] are corroded or damaged, or if the insulator [C] is cracked, replace the plug.
- ★ If the spark plug is dirtied or the carbon is accumulated, replace the spark plug.
- Measure the gap [D] with a wire-type thickness gauge.
- ★ If the gap is incorrect, replace the spark plug.

Spark Plug Gap: 0.8 ~ 0.9 mm (0.031 ~ 0.035 in.)

- Use the standard spark plug or its equivalent.

Spark Plug: CR9EIA-9

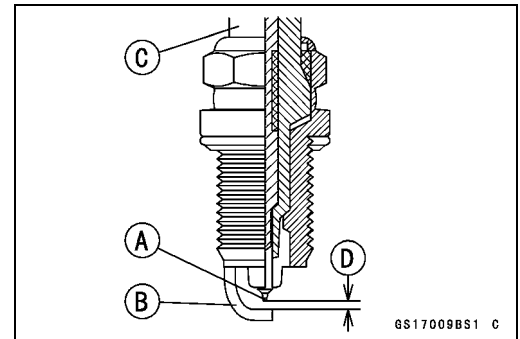

16-42 ELECTRICAL SYSTEM

Ignition System

Camshaft Position Sensor Removal

- Remove:
 - Fuel Tank Cover (see Fuel Tank Removal in the Fuel System (DFI) chapter)
 - Right Middle Fairing (see Middle Fairing Removal in the Frame chapter)
- Disconnect the camshaft position sensor lead connector [A].



- Remove:
 - Camshaft Position Sensor Bolt [A]
 - Camshaft Position Sensor [B]

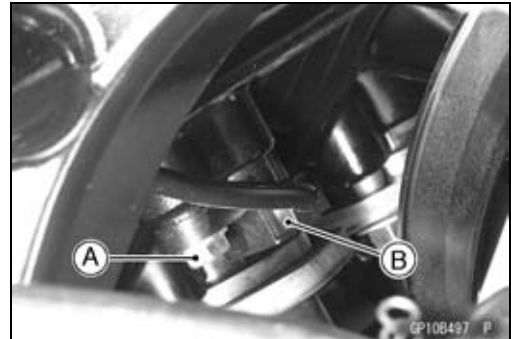

Camshaft Position Sensor Installation

- Replace the O-ring of the camshaft position sensor.
- Apply grease to the new O-ring.
- Tighten:
 - Torque - Camshaft Position Sensor Bolt: 9.8 N·m (1.0 kgf·m, 87 in·lb)**
- Route the camshaft position sensor lead correctly (see Cable, Wire, and Hose Routing section in the Appendix chapter).

Camshaft Position Sensor Inspection

- Disconnect the camshaft position sensor lead connector (see Camshaft Position Sensor Removal).
- Set the hand tester to the $\times 10 \Omega$ range and connect it to the terminals.

Special Tool - Hand Tester: 57001-1394

Camshaft Position Sensor Resistance: 400 ~ 460 Ω

- ★ If there is more resistance than the specified value, the sensor coil has an open lead and must be replaced. Much less than this resistance means the sensor coil is shorted, and must be replaced.
- Using the highest resistance range of the tester, measure the resistance between the camshaft position sensor leads and chassis ground.
- ★ Any tester reading less than infinity (∞) indicates a short, necessitating replacement of the camshaft position sensor.

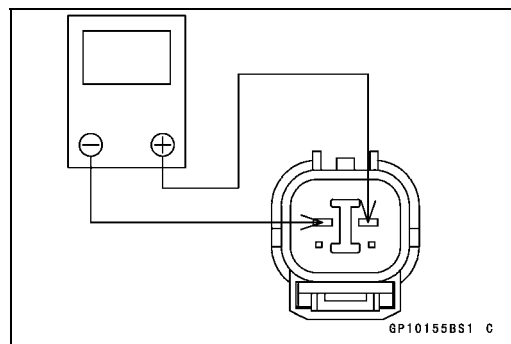

Ignition System

Camshaft Position Sensor Peak Voltage Inspection

- Disconnect the camshaft position sensor lead connector [A] (see Camshaft Position Sensor Removal).
- Connect the harness adapter [B] between the camshaft position sensor lead connector and harness connector [C].
- Connect the peak voltage adapter [D] to the hand tester [E] which is set to the $\times 10$ V range.
- Connect the adapter to the harness adapter. [F] Camshaft Position Sensor

Special Tools - Hand Tester: 57001-1394

Peak Voltage Adapter: 57001-1415

Type: KEK-54-9-B

Harness Adapter: 57001-1562

Connections:

Harness Adapter		Peak Voltage Adapter		Hand Tester
Black/White	←	Black	→	(-)
Red	←	Red	→	(+)

- Turn the ignition switch and engine stop switch ON.
- Pushing the starter button, run the engine with the transmission gear in neutral to measure the camshaft position sensor peak voltage.
- Repeat the measurement 5 or more times.

Camshaft Position Sensor Peak Voltage

Standard: 2.8 V or more

- ★ If the peak voltage is lower than the standard, inspect the camshaft position sensor.

Interlock Operation Inspection

- Using the stand [A], raise the rear wheel off the ground.

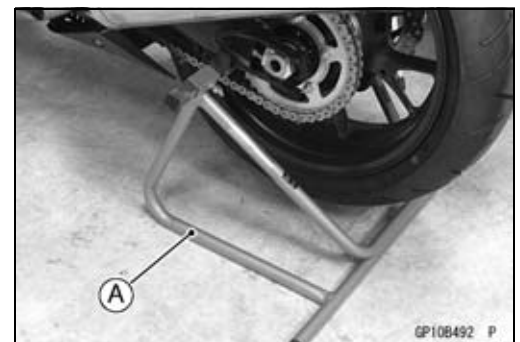
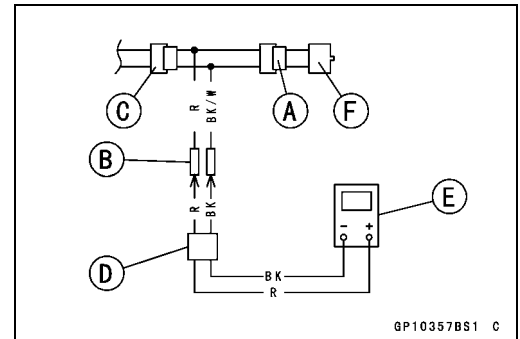
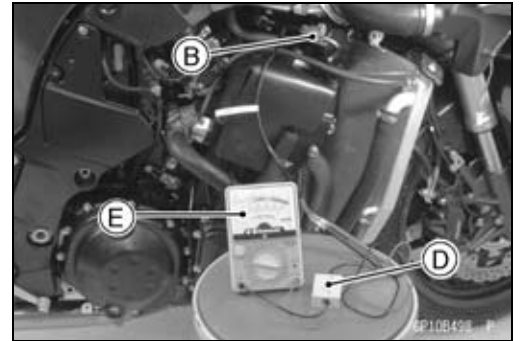

1st Check

- Start the engine to the following conditions.

Condition:

Transmission Gear → 1st Position

Clutch Lever → Release

Sidestand → Down or Up

- Turn the ignition switch ON and push the starter button.
- Then the starter motor should not turn when the starter system circuit is normality.
- ★ If the engine is start, inspect the starter lockout switch, gear position switch, and relay box.
- ★ If their parts are normality replace the ECU.

16-44 ELECTRICAL SYSTEM

Ignition System

2nd Check

- Start the engine to the following conditions.

Condition:

Transmission Gear → 1st Position

Clutch Lever → Pulled in

Sidestand → Up

- Turn the ignition switch ON and push the starter button.
- Then the starter motor should turn when the starter system circuit is normality.
- ★ If the starter motor is not turn, inspect the starter lockout switch, gear position switch, sidestand switch and relay box.
- ★ If their parts are normality replace the ECU.

3rd Check

- Inspect the engine for its secure stop after the following operations are completed.
- Run the engine to the following conditions.

Condition:

Transmission Gear → 1st Position

Clutch Lever → Release

Sidestand → Up

- Set the sidestand on the ground, then the engine will stop.
- ★ If whichever may not be stopped, inspect the gear position switch, starter lockout switch, sidestand switch and relay box.
- ★ If their parts are normality, replace the ECU.

IC Igniter Inspection

- The IC igniter is built in the ECU [A].
- Refer to the following items.
 - Interlock Operation Inspection (see Interlock Operation Inspection)
 - Ignition System Troubleshooting (see Ignition System section)
 - ECU Power Supply Inspection (see ECU Power Supply Inspection in the Fuel System (DFI) chapter)

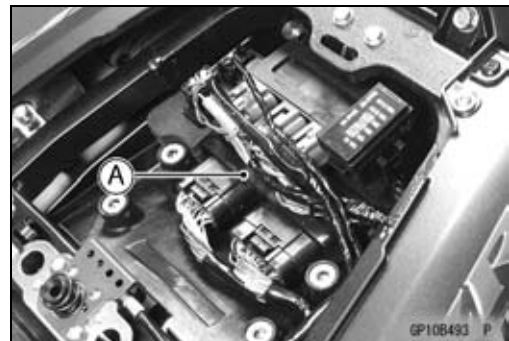

Ignition System

Ignition System Circuit

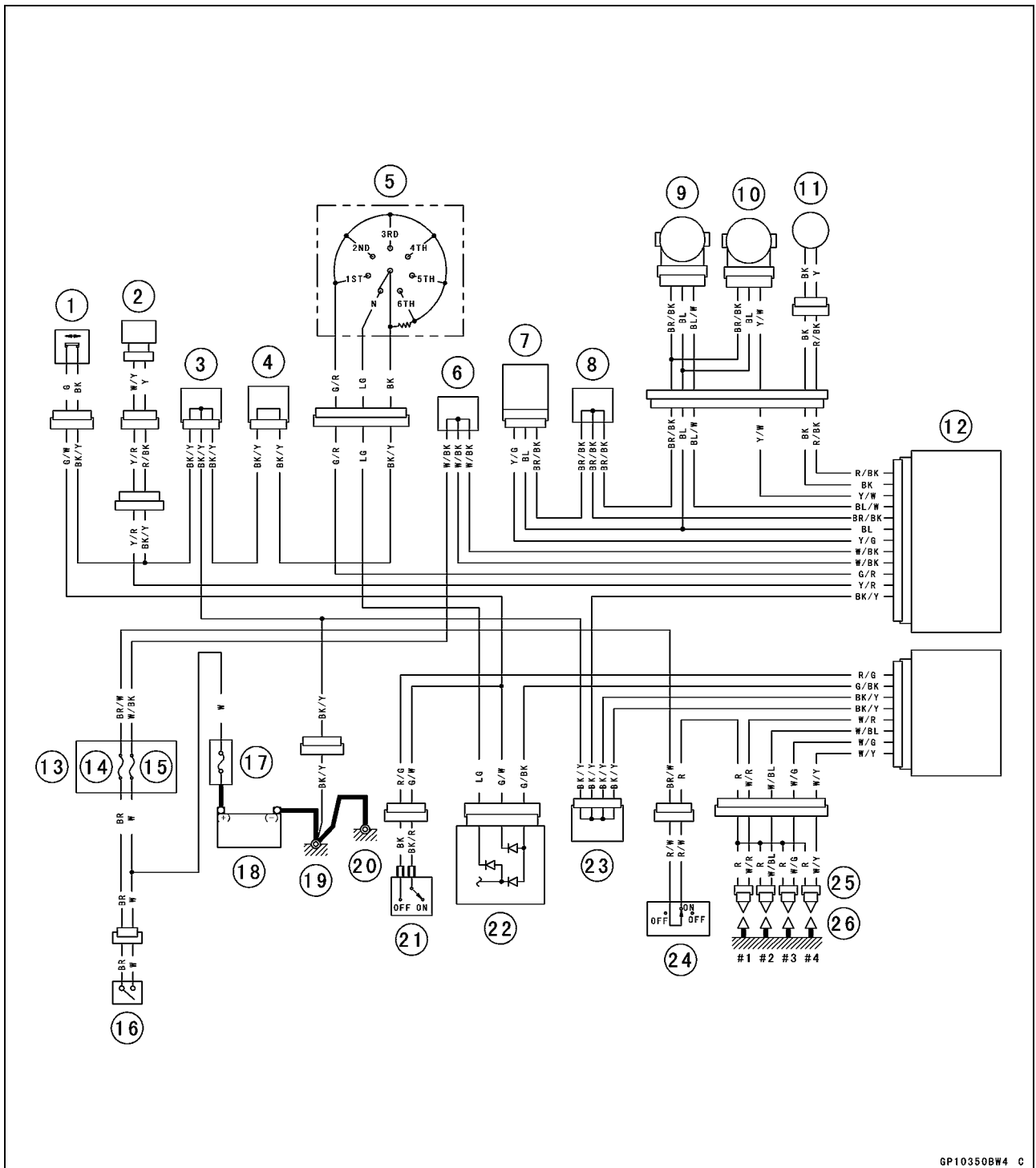

GP10350BW4 C

- | | |
|-----------------------------|----------------------------|
| 1. Sidestand Switch | 14. Ignition Fuse 10 A |
| 2. Camshaft Position Sensor | 15. ECU Fuse 15 A |
| 3. Joint Connector 1 | 16. Ignition Switch |
| 4. Joint Connector 2 | 17. Main Fuse 30 A |
| 5. Gear Position Switch | 18. Battery 12 V 14 Ah |
| 6. Water-proof Joint 1 | 19. Frame Ground 2 |
| 7. Vehicle-down Sensor | 20. Engine Ground |
| 8. Water-proof Joint 2 | 21. Starter Lockout Switch |
| 9. Sub-throttle Sensor | 22. Relay Box |
| 10. Main Throttle Sensor | 23. Joint Connector 3 |
| 11. Crankshaft Sensor | 24. Engine Stop Switch |
| 12. ECU | 25. Stick Coils |
| 13. Fuse Box 2 | 26. Spark Plugs |

16-46 ELECTRICAL SYSTEM

Electric Starter System

Starter Motor Removal

- Remove:
 - Engine Sprocket Cover (see Engine Sprocket Removal in the Final Drive chapter)
 - Take off the heat insulation rubber plate [A].
 - Slide out the rubber cap [B].
 - Remove the starter motor cable terminal nut [C].
-
- Remove the starter motor mounting bolts [A].
 - Pull out the starter motor [B] from the left side.

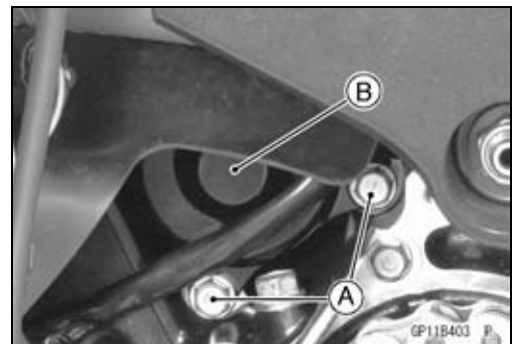
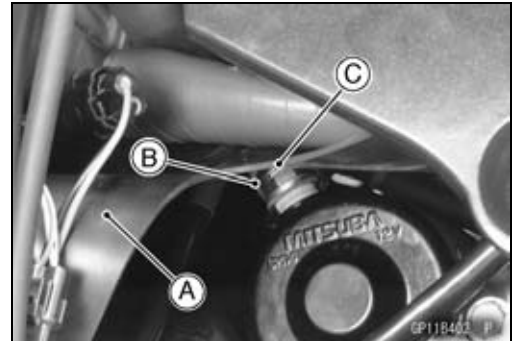

Starter Motor Installation

CAUTION

Do not tap the starter motor shaft or body. Tapping the shaft or body could damage the motor.

- Clean the starter motor legs [A] and crankcase [B] where the starter motor is ground.
- Replace the O-ring [C] with a new one.
- Apply grease to the new O-ring.
- Tighten:
 - Torque - Starter Motor Mounting Bolts: 9.8 N·m (1.0 kgf·m, 87 in·lb)**
- Install the starter motor cable [A] side by side with starter motor [B].
- Tighten:
 - Torque - Starter Motor Cable Terminal Nut: 5.9 N·m (0.60 kgf·m, 52 in·lb)**
- Slide back the rubber cap [C] to the original position.

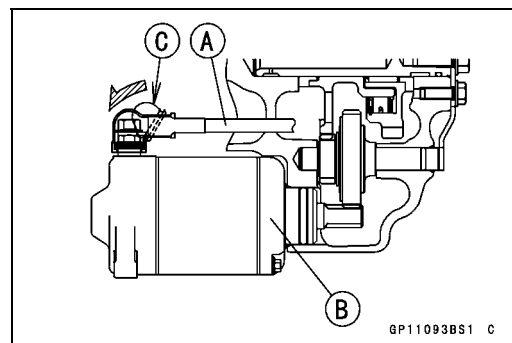
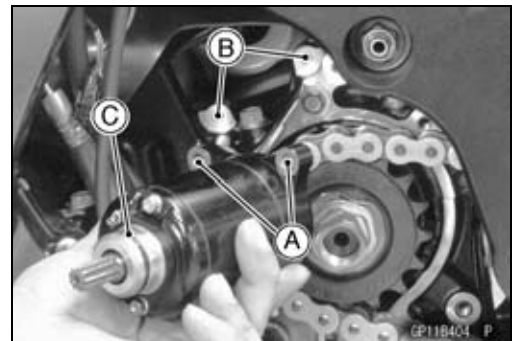

Electric Starter System

Starter Motor Disassembly

- Remove the starter motor (see Starter Motor Removal).
- Take off the starter motor through bolts [A] and remove both end covers [B].

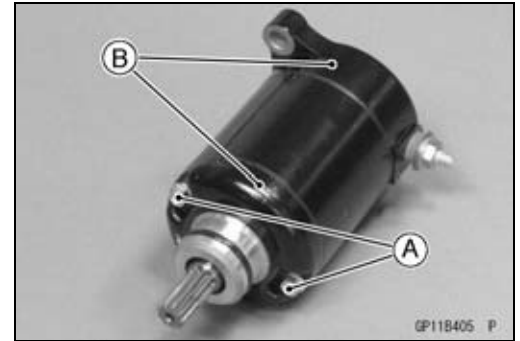

- Pull the armature [A] out of the yoke [B].

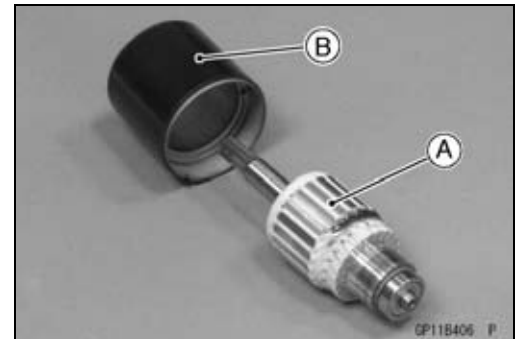

- Remove:
 - Brush Plate Terminal Nut, Washer and Insulators [A]
 - Brush Plate Assembly [B]

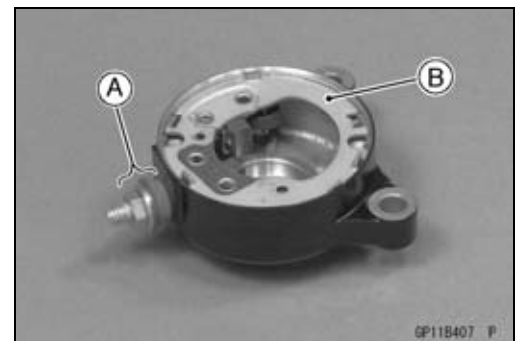

Starter Motor Assembly

- Pry the spring end [A] and insert the brush [B].

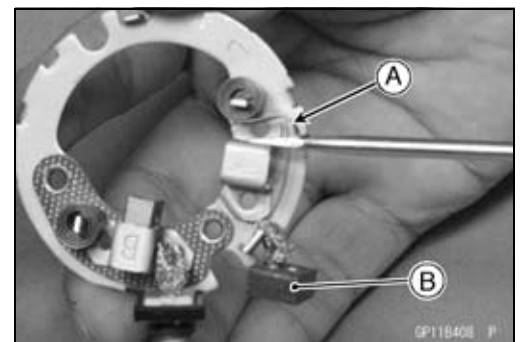

- Install the brush plate assembly [A] into the right-hand end cover [B].
- Replace the O-ring [C] with a new one.
- Install:
 - Insulators [D]
 - Washer [E]
- Tighten:
 - Torque - Starter Motor Terminal Locknut [F]: 6.9 N·m (0.70 kgf·m, 61 in·lb)**

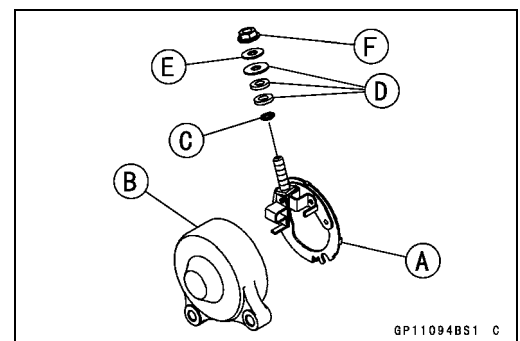

16-48 ELECTRICAL SYSTEM

Electric Starter System

- Install the armature [A] into the yoke [B].
- Install thrust washer [C].
- Replace the O-rings [D] with new ones.
- Put the armature [E] among the brushes [F].

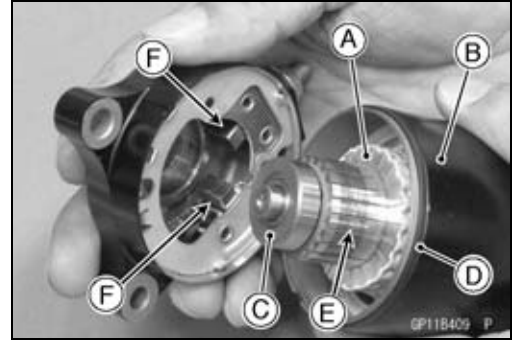

- Align the marks [A] to assembly the yoke and the end covers.

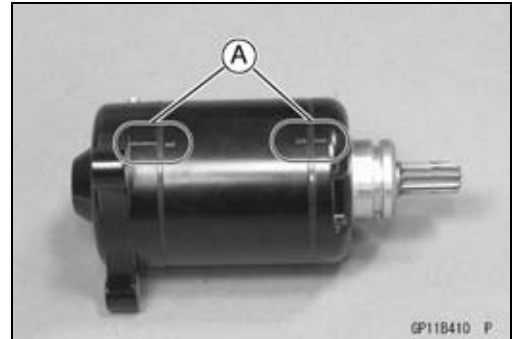

- Replace the O-rings [A] with new ones.
- Tighten:
Torque - Starter Motor Through Bolts [B]: 3.4 N·m (0.35 kgf·m, 30 in·lb)

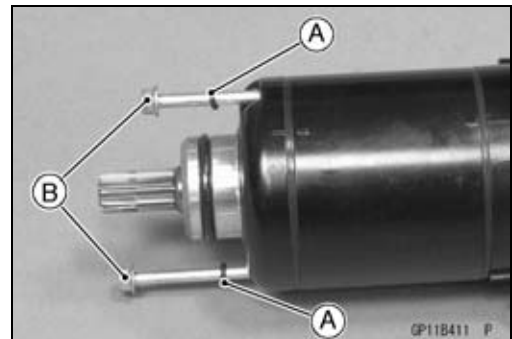

- Replace the O-ring [A] with new ones.
- Apply grease to the new O-ring.

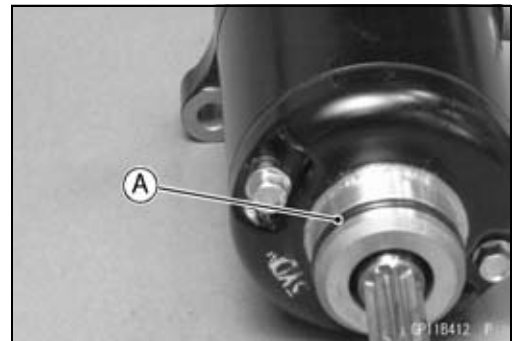

Brush Inspection

- Measure the length [A] of each brush [B].
- ★ If any is worn down to the service limit, replace the brush holder assembly.

Starter Motor Brush Length

Standard: 10 mm (0.39 in.)

Service Limit: 5.0 mm (0.20 in.)

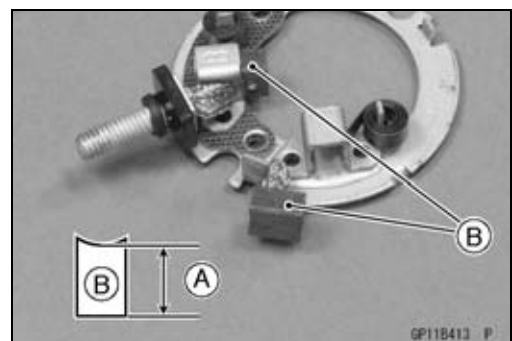

Electric Starter System

Commutator Cleaning and Inspection

- Smooth the commutator surface [A] if necessary with fine emery cloth [B], and clean out the grooves.

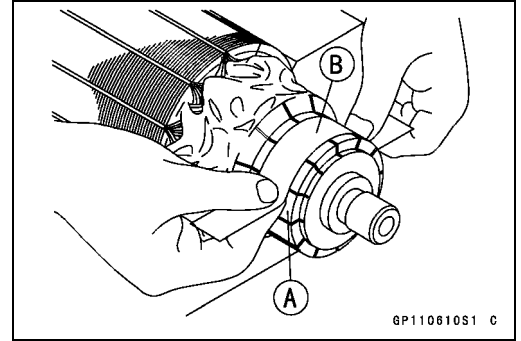

- Measure the diameter [A] of the commutator [B].
- ★ If the commutator diameter is less than the service limit, replace the starter motor with a new one.

Commutator Diameter

Standard: 28 mm (1.10 in.)

Service Limit: 27 mm (1.06 in.)

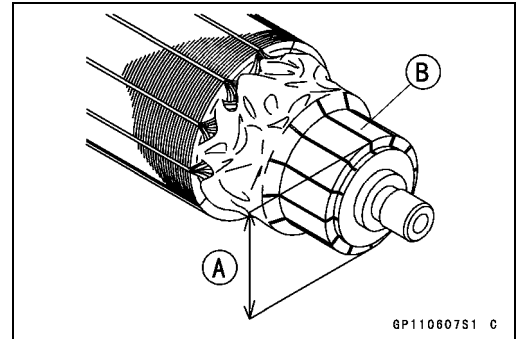

Armature Inspection

- Using the $\times 1 \Omega$ hand tester range, measure the resistance between any two commutator segments [A].

Special Tool - Hand Tester: 57001-1394

- ★ If there is a high resistance or no reading (∞) between any two segments, a winding is open and the starter motor must be replaced.
- Using the highest hand tester range, measure the resistance between the segments and the shaft [B].
- ★ If there is any reading at all, the armature has a short and the starter motor must be replaced.

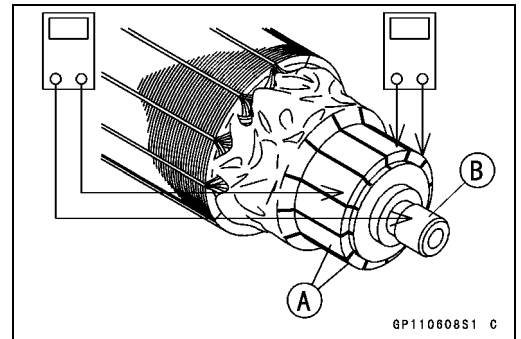

NOTE

○ Even if the foregoing checks show the armature to be good, it may be defective in some manner not readily detectable with the hand tester. If all other starter motor and starter motor circuit components check good, but the starter motor still does not turn over or only turns over weakly, replace the starter motor with a new one.

Brush Lead Inspection

- Using the $\times 1 \Omega$ hand tester range, measure the resistance as shown.

Terminal Bolt and Positive Brush [A]

Right-hand End Cover and Negative Brush [B]

Special Tool - Hand Tester: 57001-1394

- ★ If there is not close to zero ohms, the brush lead has an open. Replace the brush holder assembly.

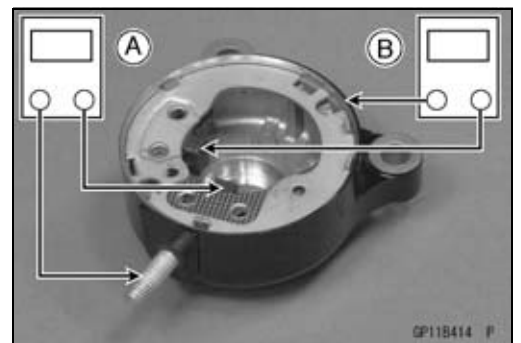

16-50 ELECTRICAL SYSTEM

Electric Starter System

Right-hand End Cover Assembly Inspection

- Using the highest hand tester range, measure the resistance as shown.

Terminal and Right-hand End Cover [A]

Special Tool - Hand Tester: 57001-1394

- ★ If there is any reading, the right-hand end cover assembly have a short. Replace the right-hand end cover assembly.

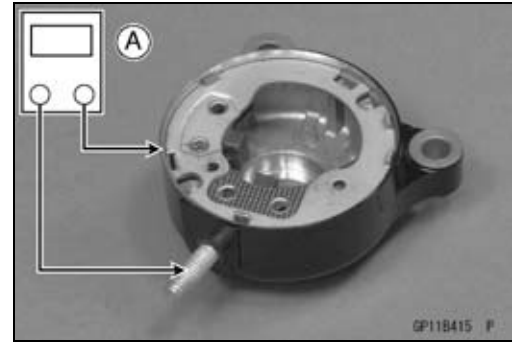

Starter Relay Inspection

- Remove the battery (see Battery Removal).
- Disconnect the starter motor cable [A] and battery positive (+) cable [B] from the starter relay.
- Disconnect the connector [C].
- Pull out the starter relay from the damper.

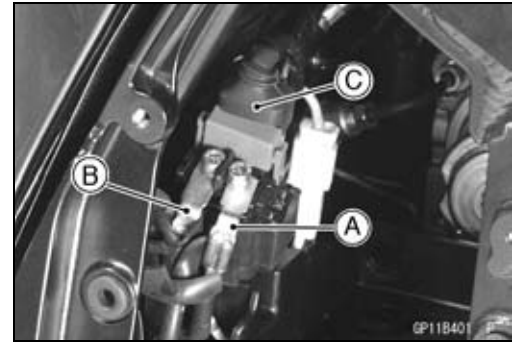

- Connect the hand tester [A] and 12 V battery [B] to the starter relay [C] as shown.

Special Tool - Hand Tester: 57001-1394

- ★ If the relay does not work as specified, the relay is defective. Replace the relay.

Testing Relay

Tester Range: × 1 Ω range

Criteria: When battery is connected → 0 Ω

When battery is disconnected → ∞ Ω

- Tighten:

Torque - Starter Motor Cable Mounting Bolt: 3.9 N·m (0.40 kgf·m, 35 in·lb)

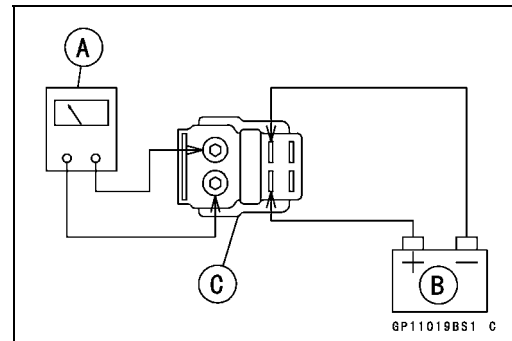

Electric Starter System

Electric Starter Circuit

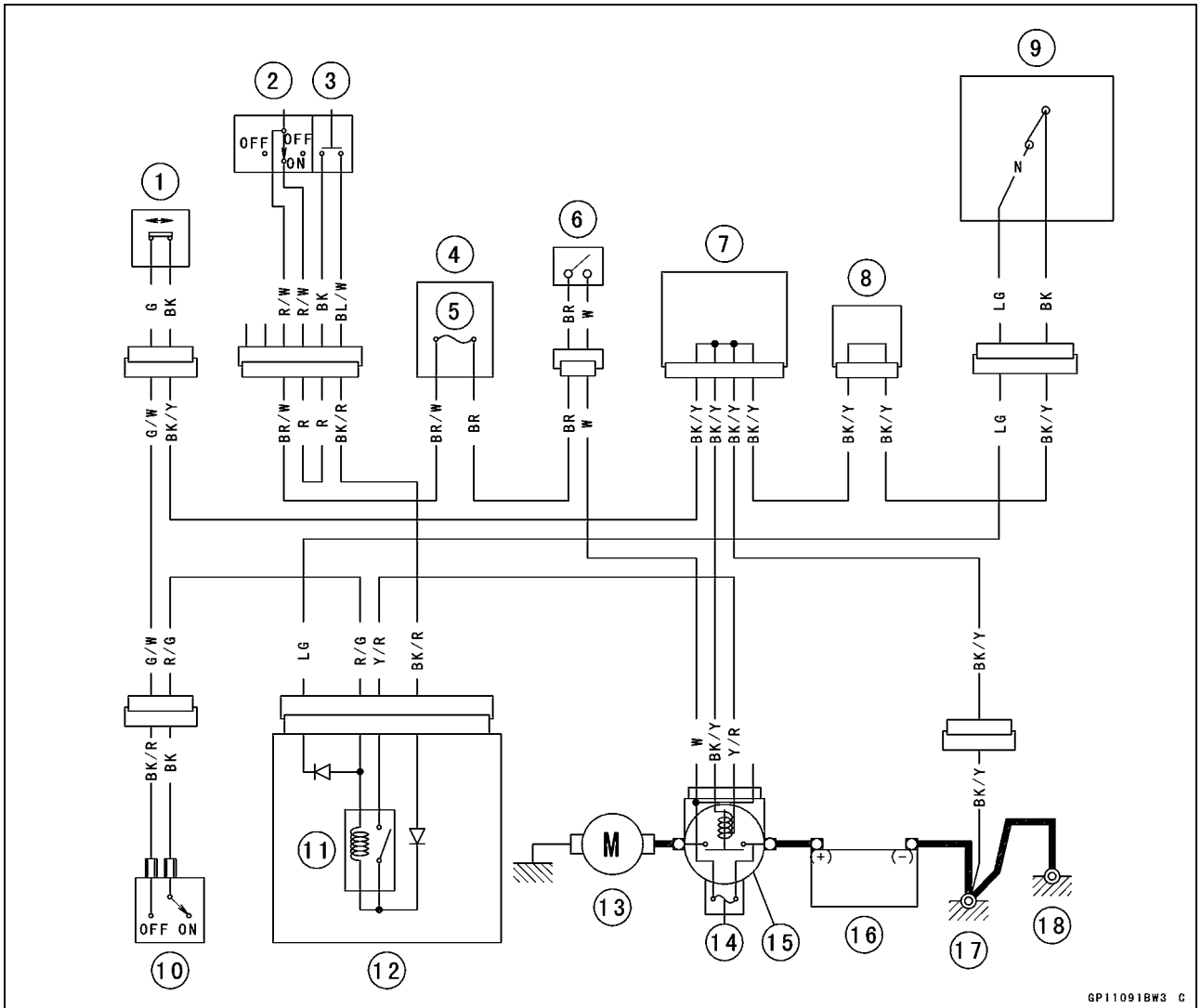

GP11091BW3 C

1. Sidstand Switch
2. Engine Stop Switch
3. Starter Button
4. Fuse Box 2
5. Ignition Fuse 10 A
6. Ignition Switch
7. Joint Connector 1
8. Joint Connector 2
9. Gear Position Switch
10. Starter Lockout Switch
11. Starter Circuit Relay
12. Relay Box
13. Starter Motor
14. Main Fuse 30 A
15. Starter Relay
16. Battery 12 V 14 Ah
17. Frame Ground 2
18. Engine Ground

16-52 ELECTRICAL SYSTEM

Lighting System

This motorcycle adopt the daylight system and have a headlight relay in the relay box. The headlight does not go on when the ignition switch and the engine stop switch are first turned on. The headlight comes on after the starter button is released and stays on until the ignition switch is turned off. The headlight will go out momentarily whenever the starter button is pressed and come back on when the button is released.

Headlight Beam Horizontal Vertical Adjustment

- Refer to the Headlight Aiming Inspection in the Periodic Maintenance chapter.

Headlight Beam Vertical Adjustment

- Refer to the Headlight Aiming Inspection in the Periodic Maintenance chapter.

Headlight Bulb Replacement

- Remove the inner covers (see Inner Cover Removal in the Frame chapter).
- Disconnect the headlight connector [A].



- Turn the headlight bulb [A] counterclockwise and pull out the bulb from the headlight.

CAUTION

When handling the quartz-halogen bulb, never touch the glass portion with bare hands. Always use a clean cloth. Oil contamination from hands or dirty rags can reduce bulb life or cause the bulb to explode.



NOTE

○Clean off any contamination that inadvertently gets on the bulb with alcohol or soap and water solution.

- Replace the headlight bulb.
- Fit the projections [A] of the bulb in the hollows [B] of the headlight.

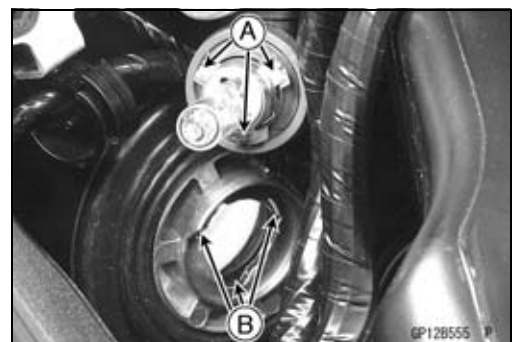

- Turn the headlight bulb clockwise.
 - Connect the headlight connector.
 - After installation, adjust the headlight aim (see Headlight Aiming Inspection in the Periodic Maintenance chapter).
- Other Bulbs: Repeat the above steps.

Lighting System

City Light Bulb Replacement

- Remove the inner covers (see Inner Cover Removal in the Frame chapter).
- Unscrew the screw [A].
- Disconnect the city light connector [B].

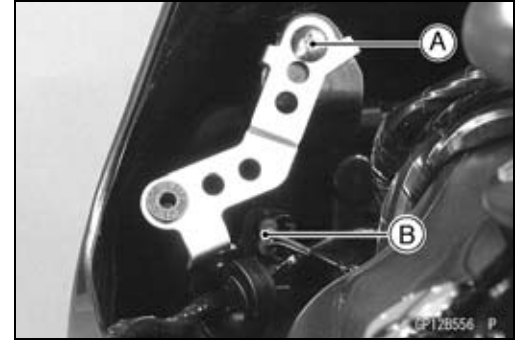

- Turn the city light bulb counterclockwise and pull out the socket [A] together with the bulb.

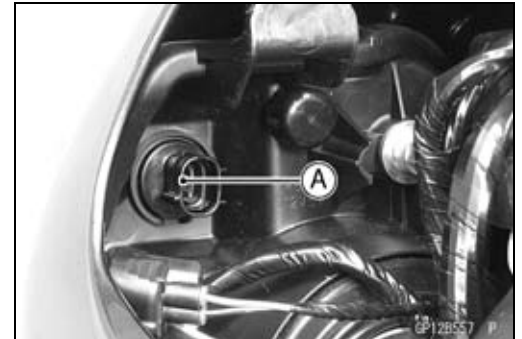

- Pull the bulb [A] out of the socket [B].

CAUTION

Do not turn the bulb. Pull the bulb out to prevent damage to the bulb. Do not use bulb rated for greater wattage than the specified value.

- Replace the bulb with a new one.

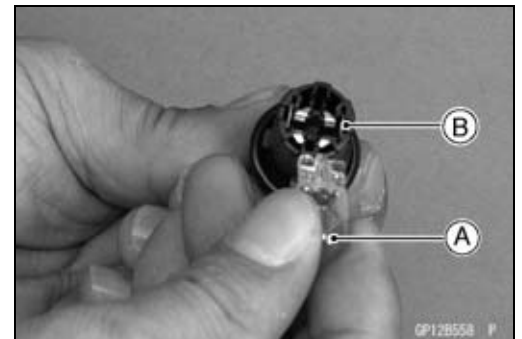

- Insert the socket and to the headlight.
 - Align the projections [A] of the socket and the grooves [B] of the headlight.
- Turn the city light bulb clockwise.
- Connect the city light connector.

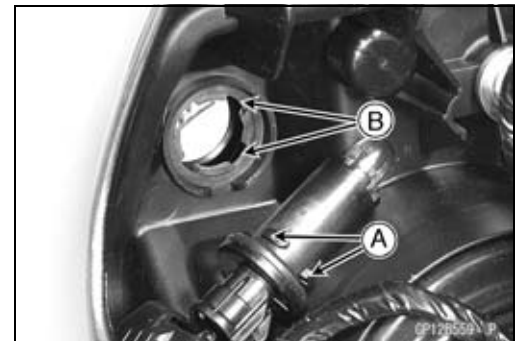

Headlight Removal/Installation

- Remove:
 - Upper Fairing (see Upper Fairing Removal in the Frame chapter)
 - Upper Inner Fairing (see Upper Inner Fairing Removal in the Frame chapter)
 - Headlight Mounting Screws [A]
 - Headlights [B]
- Tighten:

Torque - Headlight Mounting Screws: 1.2 N·m (0.12 kgf·m, 11 in·lb)

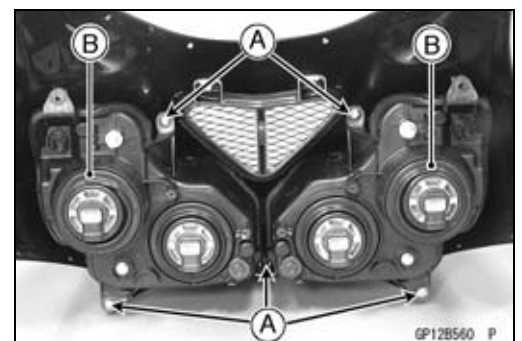

16-54 ELECTRICAL SYSTEM

Lighting System

Headlight Relay Inspection

- Remove the inner covers (see Inner Cover Removal in the Frame chapter).
- Take off the headlight relay [A] (both sides).

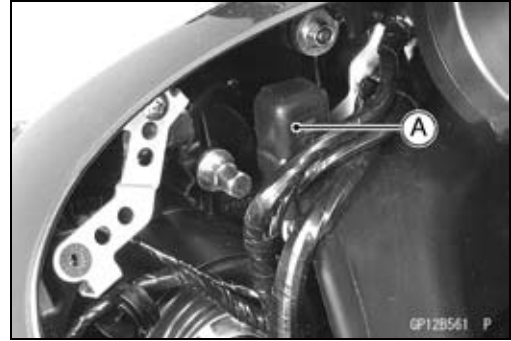

- Set the hand tester to the $\times 1 \Omega$ range and make the measurements shown in the figure.

Headlight Relay [A]
12 V Battery [B]

Special Tool - Hand Tester [C]: 57001-1394

- ★ If the tester readings are not as specified, replace the headlight relay.

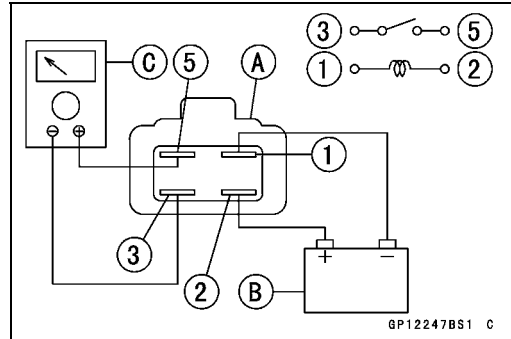

CAUTION

Use only Hand Tester 57001-1394 for this test. An ohmmeter other than the Kawasaki Hand Tester may show different readings. If a megger or a meter with a large-capacity battery is used, the headlight relay will be damaged.

Testing Relay

- Criteria When battery is connected $\rightarrow 0 \Omega$
 When battery is disconnected $\rightarrow \infty \Omega$

Tail/Brake Light (LED) Removal

- Remove:
 - Tool Kit Case [A] (see ECU Removal in the Fuel System (DFI) chapter)
 - Relay Box [B] (see Relay Box Removal in the Electrical System chapter)
 - Fuse Box [C]
 - Screws [D]

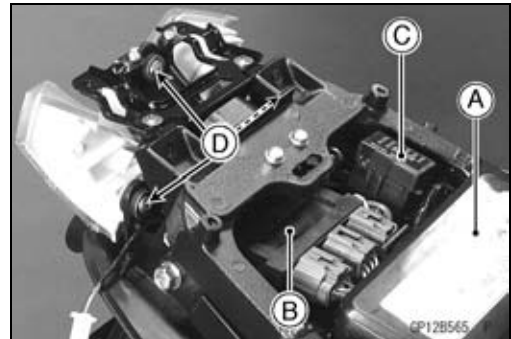

- Disconnect the connector [A].
- Remove the tail/brake light [B].

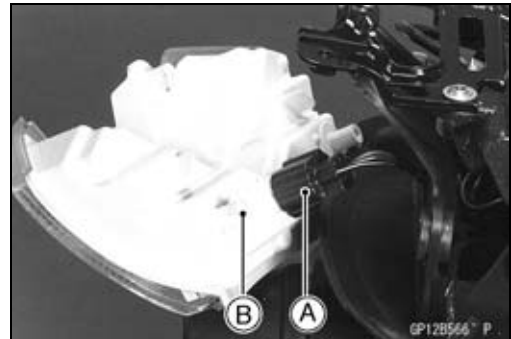

Lighting System

Tail/Brake Light (LED) Installation

- Connect the connector.
- Insert the projections [A] of the tail/brake light into the holes [B] of the rear fender.

Torque - Tail/Brake Light Mounting Screws: 1.2 N·m (0.12 kgf·m, 11 in·lb)

- Install the removed parts (see appropriate chapters).

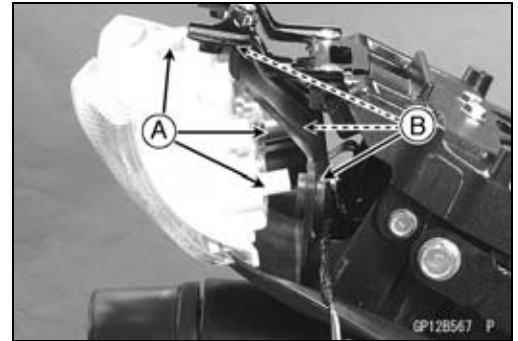

License Plate Light Bulb Replacement

- Remove:
 - Screws [A]
 - License Plate Light Cover [B]

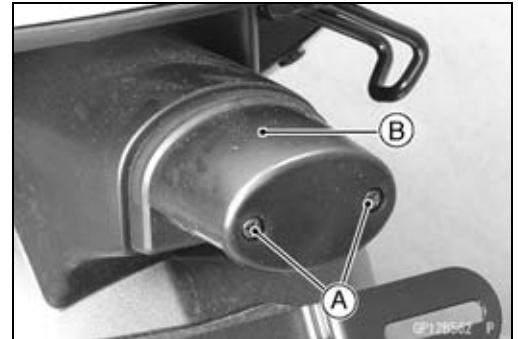

- Push and turn the bulb [A] counterclockwise and remove it.
- Replace the bulb with a new one.



- Insert the new bulb [A] by aligning its upper and lower pins [B] with the upper and lower grooves [C] in the socket, and turn the bulb clockwise.

○ Turn the bulb about 15°.

- Tighten:

Torque - Licence Plate Light Cover Mounting Screws: 0.9 N·m (0.09 kgf·m, 8 in·lb)

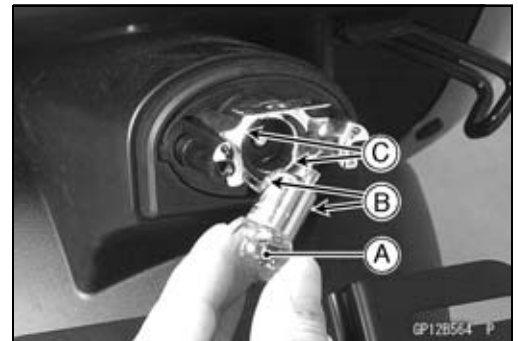

16-56 ELECTRICAL SYSTEM

Lighting System

Headlight/Tail Light Circuit

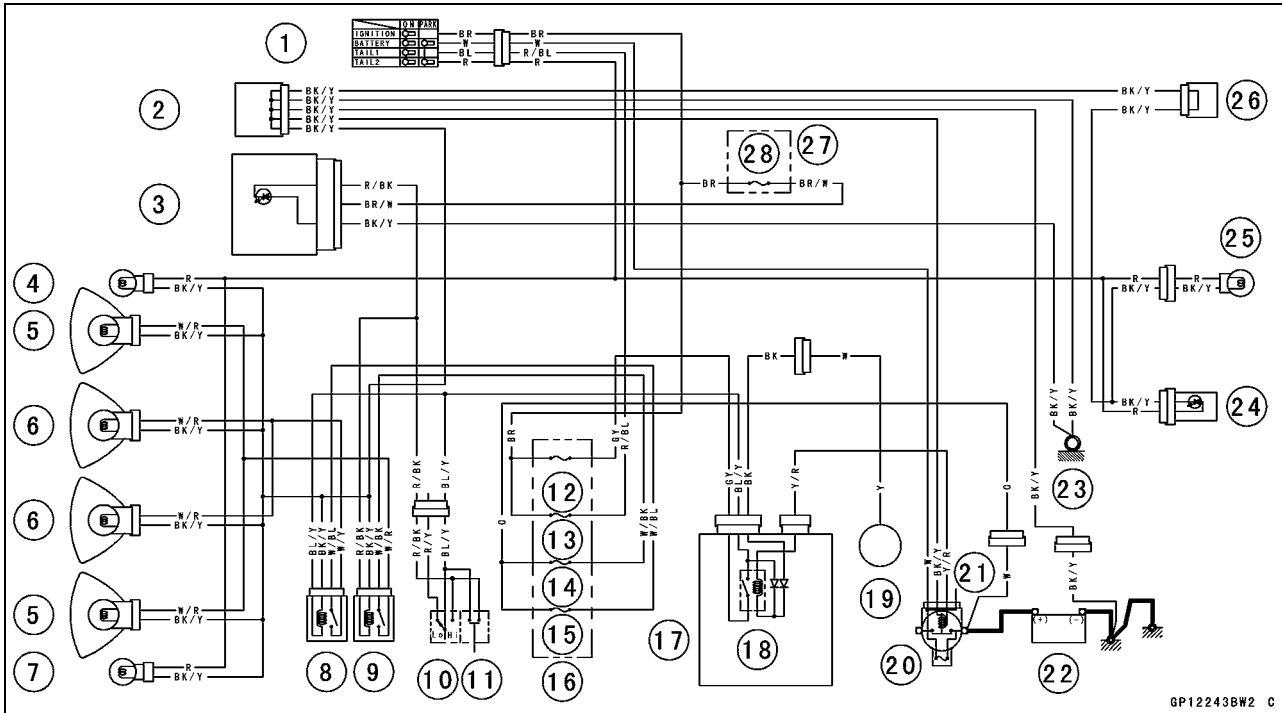

- | | |
|---|-------------------------------|
| 1. Ignition Switch | 15. Headlight Fuse (Low) 10 A |
| 2. Joint Connector 1 | 16. Fuse Box 1 |
| 3. High Beam Indicator Light (LED) | 17. Relay Box |
| 4. Right City Light | 18. Headlight Circuit Relay |
| 5. Headlight (High Beam) | 19. Alternator |
| 6. Headlight (Low Beam) | 20. Main Fuse 30 A |
| 7. Left City Light | 21. Starter Relay |
| 8. Headlight Relay (Low) | 22. Battery 12 V 14 Ah |
| 9. Headlight Relay (High) | 23. Frame Ground |
| 10. Dimmer Switch | 24. Tail/Brake Light (LED) |
| 11. Passing Button (Other than US Models) | 25. License Plate Light |
| 12. Headlight Fuse 10 A | 26. Joint Connector 2 |
| 13. Taillight Fuse 10 A | 27. Fuse Box 2 |
| 14. Headlight Fuse (High) 10 A | 28. Ignition Fuse 10 A |

Turn Signal Light Bulb Replacement

Front Turn Signal Light

- Remove:
 - Middle Fairings (see Middle Fairing Removal in the Frame chapter)
 - Inner Fairings (see Inner Fairing Removal in the Frame chapter)
- Turn the socket [A] counterclockwise and pull out the socket together with the bulb.

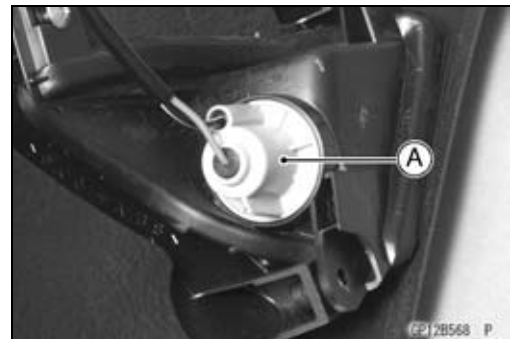

Lighting System

- Push and turn the front turn signal light bulb [A] counter-clockwise and remove it.
- Replace the bulb with new ones.



- Insert the new bulb [A] by aligning its upper and lower pins [B] with the upper and lower grooves [C] in the socket, and turn the bulb clockwise.
- Turn the bulb about 15°.

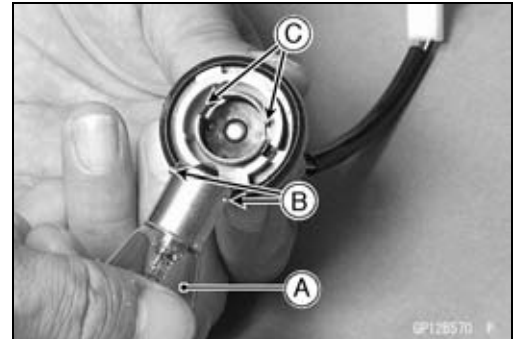

- Pushing the socket and turn it clockwise.
- Fit the projections [A] of the socket into the grooves [B] of the turn signal light.
- Install the middle fairings (see Middle Fairing Installation in the Frame chapter).

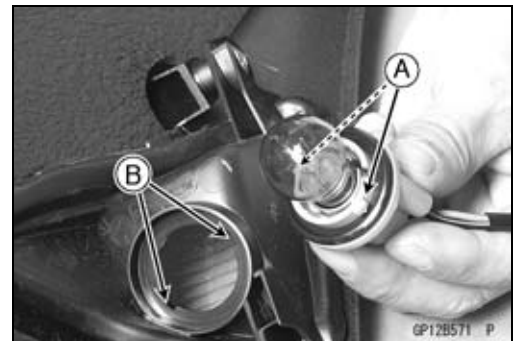

Rear Turn Signal Light

- Remove:
 - Screw [A]
 - Rear Turn Signal Light Lens [B]

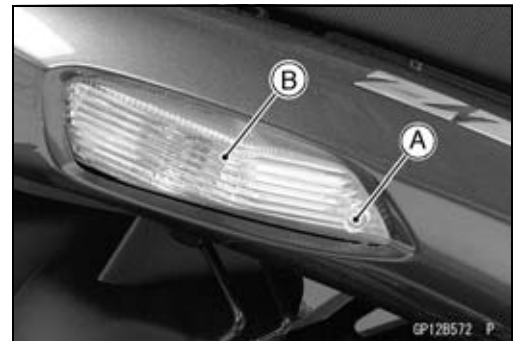

- Push and turn the rear turn signal light bulb [A] counter-clockwise and remove it.



16-58 ELECTRICAL SYSTEM

Lighting System

- Insert the new bulb [A] by aligning its upper and lower pins [B] with the upper and lower grooves [C] in the socket, and turn the bulb clockwise.
- Turn the bulb about 15°.

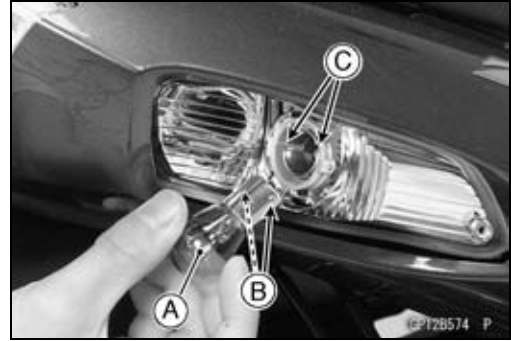

- Fit the projections [A] of the lens into the grooves [B] of the turn signal light.
- Tighten the screw.



Turn Signal Relay Inspection

- Remove:
 - Left Seat Cover (see Seat Cover Removal in the Frame chapter)
 - Turn Signal Relay [A]
- Disconnect the connector [B].

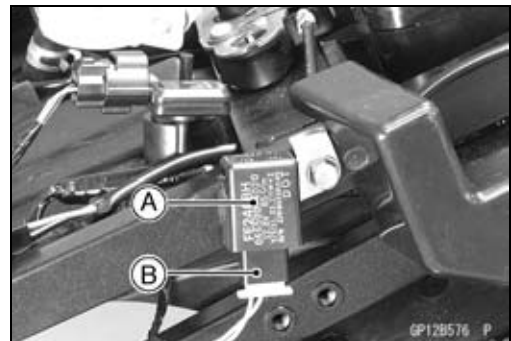

- Connect one 12 V battery and turn signal lights as indicated in the figure, and count how many times the lights flash for one minute.
 - Turn Signal Relay [A]
 - Turn Signal Lights [B]
 - 12 V Battery [C]
- ★ If the lights do not flash as specified, replace the turn signal relay.

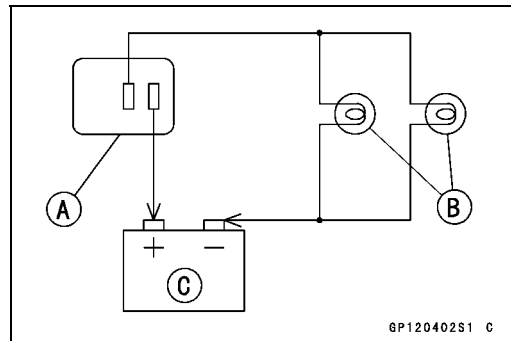

Testing Turn Signal Relay

Load		Flashing Times (c/m*)
The Number of Turn Signal Lights	Wattage (W)	
1**	21 or 23	140 ~ 250
2	42 or 46	75 ~ 95

*: Cycle(s) per minute

** : Corrected to "one light burned out".

Lighting System

Turn Signal Light Circuit

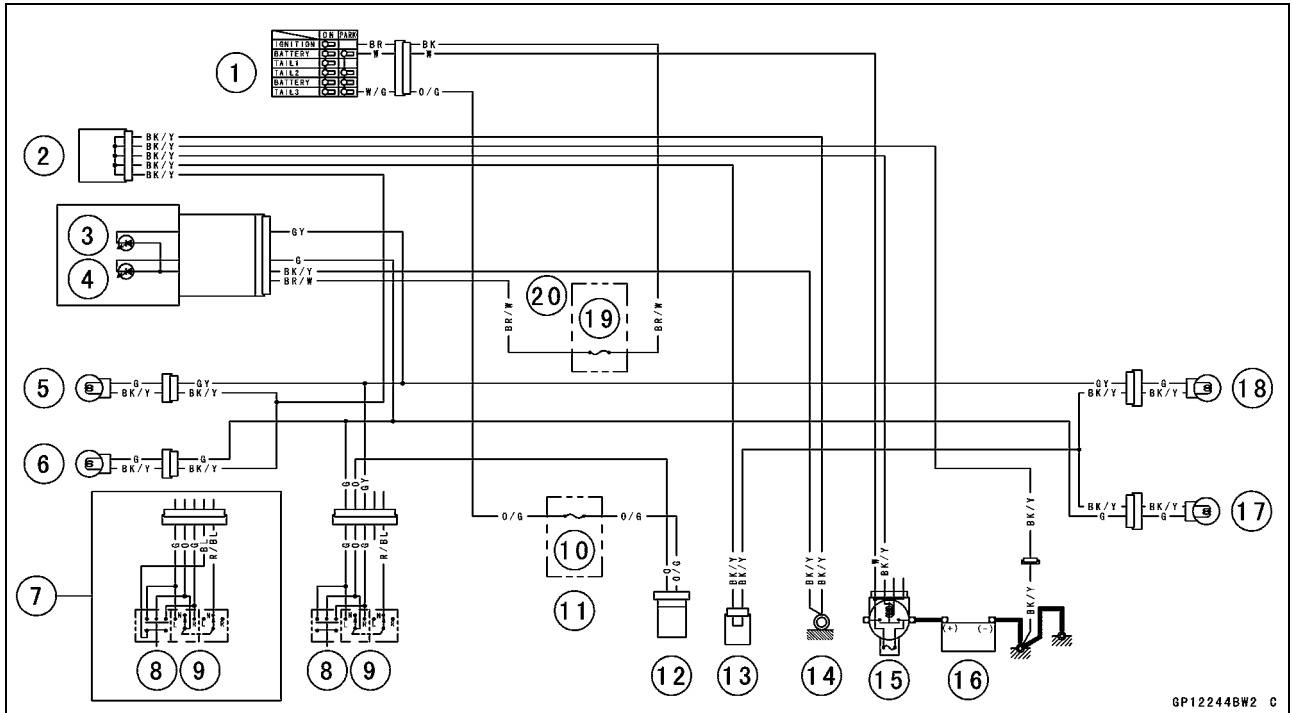

1. Ignition Switch
2. Joint Connector 1
3. Turn Signal Indicator Light (LED) (Right)
4. Turn Signal Indicator Light (LED) (Left)
5. Front Right Turn Signal Light
6. Front Left Turn Signal Light
7. Other than US Models
8. Hazard Button
9. Turn Signal Switch
10. Turn Signal Fuse 10 A
11. Fuse Box 1
12. Turn Signal Relay
13. Joint Connector 2
14. Frame Ground
15. Main Fuse 30 A
16. Battery 12 V 14 Ah
17. Rear Left Turn Signal Light
18. Rear Right Turn Signal Light
19. Ignition Fuse 10 A
20. Fuse Box 2

16-60 ELECTRICAL SYSTEM

Air Switching Valve

Air Switching Valve Operation Test

- Refer to the Air Suction System Damage Inspection in the Periodic Maintenance chapter.

Air Switching Valve Unit Test

- Remove the air switching valve (see Air Switching Valve Removal in the Engine Top End chapter).
- Set the hand tester [A] to the $\times \Omega$ range and connect it to the air switching valve terminals as shown.

Special Tool - Hand Tester: 57001-1394

Air Switching Valve Resistance

Standard: 18 ~ 22 Ω at 20°C (68°F)

- ★ If the resistance reading is except the specified value, replace it with a new one.
- Connect the 12 V battery [A] to the air switching valve terminals as shown.

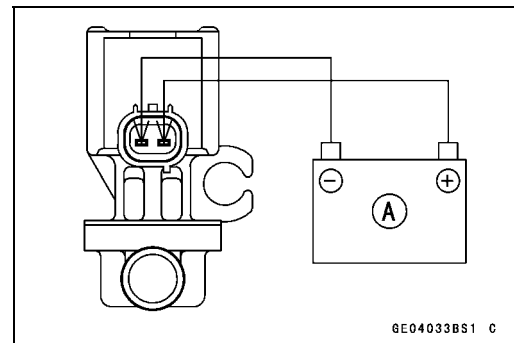
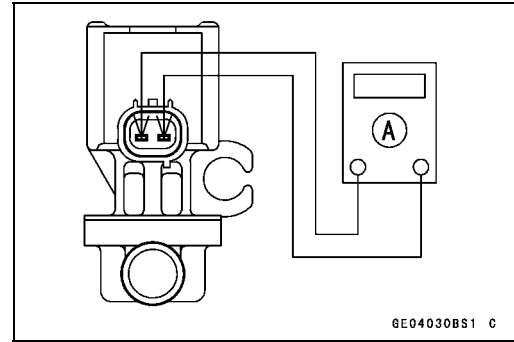

- Blow the air to the inlet air duct [A], and make sure does not flow the blown air from the outlet air ducts [B].

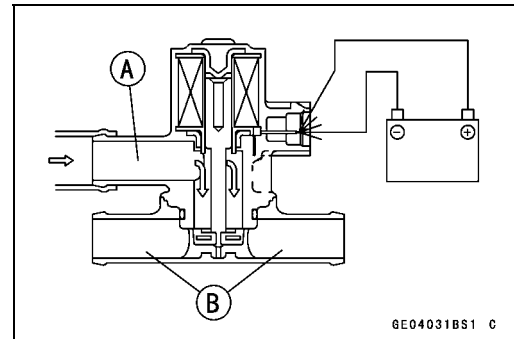

- Disconnect the 12 V battery.
- Blow the air to the inlet air duct [A] again, and make sure flow the blown air from the outlet air ducts [B].
- ★ If the air switching valve does not operate as described, replace it with a new one.

NOTE

- To check air flow through the air switching valve, just blow through the air switching valve hose (inlet side) [C].

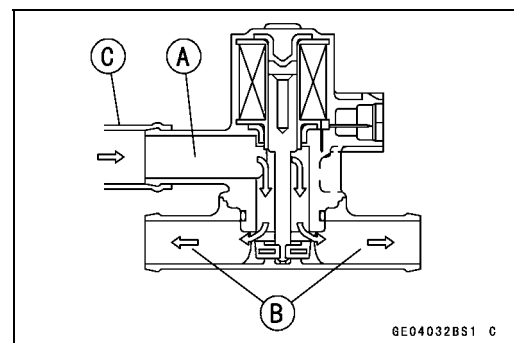

Radiator Fan System

Fan Motor Inspection

- Remove the left fairing cover (see Fairing Cover Removal in the Frame chapter).
- Disconnect the connector [A].
- Using an auxiliary leads, supply battery power to the fan motor.
- ★ If the fan does not rotate, the fan motor is defective and must be replaced.

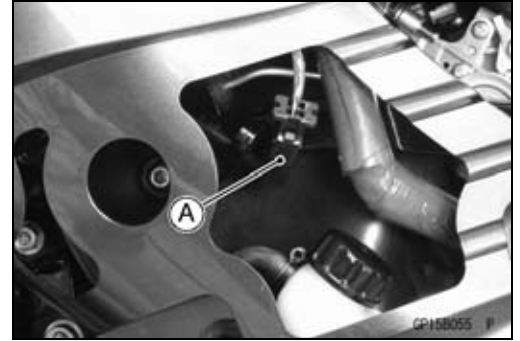

Radiator Fan Circuit

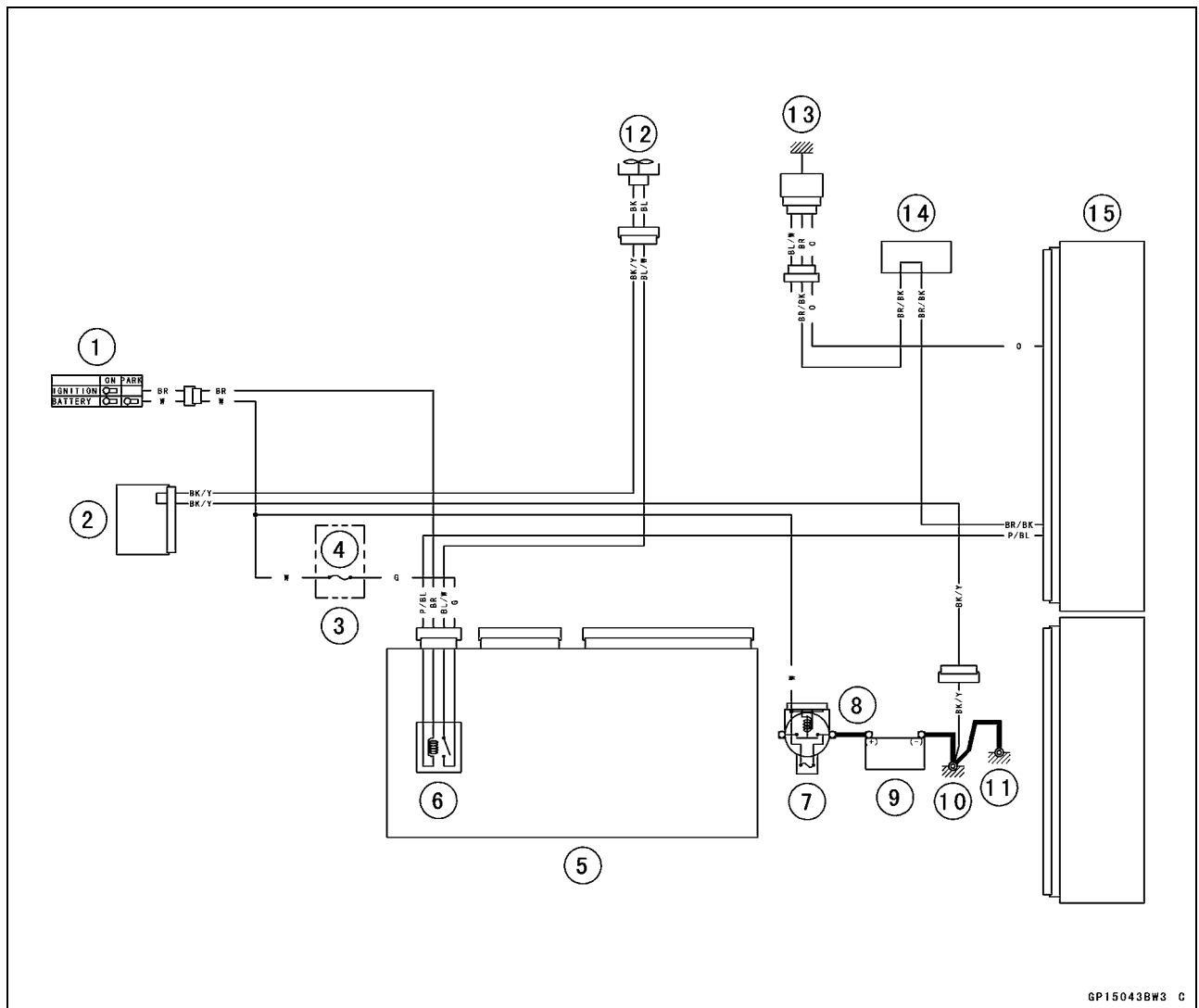

1. Ignition Switch
2. Joint Connector 1
3. Fuse Box 2
4. Fan Fuse 15 A
5. Relay Box
6. Radiator Fan Relay
7. Main Fuse 30 A
8. Starter Relay

9. Battery 12 V 14 Ah
10. Frame Ground 2
11. Engine Ground
12. Radiator Fan
13. Water Temperature Sensor
14. Water-proof Joint 2
15. ECU

16-62 ELECTRICAL SYSTEM

Meter, Gauge, Indicator Unit

Meter Unit Removal

- Remove:
 - Windshield (see Windshield Removal in the Frame chapter)
 - Immobilizer Amplifier [A] (Equipped Models)

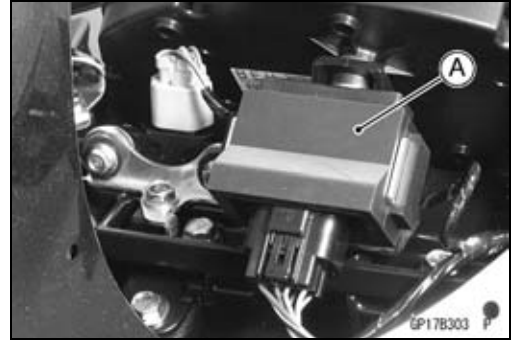

- Remove:
 - Immobilizer Amplifier Bracket and Bolt [A] (Equipped Models)
 - Vehicle-down Sensor Bracket and Bolt [B]
 - Meter Lead Connector [C]

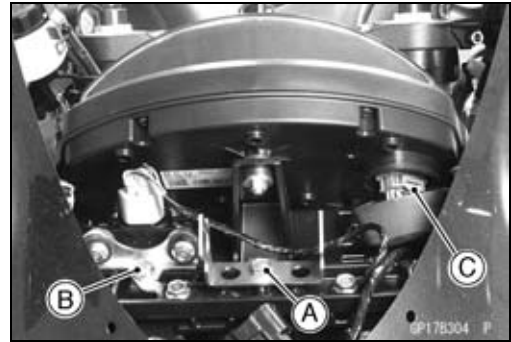

- Remove:
 - Meter Unit Mounting Nuts [A] and Washers
 - Meter Unit [B]

CAUTION

Place the meter unit so that the face is up. If a meter unit is left upside down or sideways for any length of time, it will malfunction.

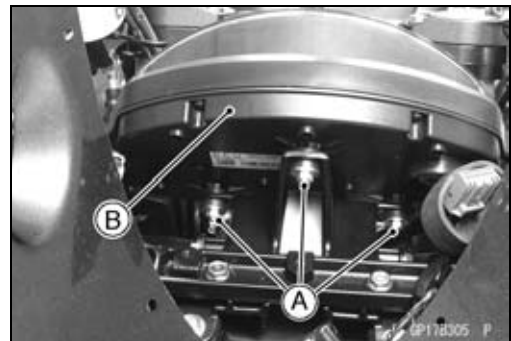

Meter Unit Installation

- Install:
 - Meter Unit [A]
 - Washers [B] and Meter Unit Mounting Nuts [C]

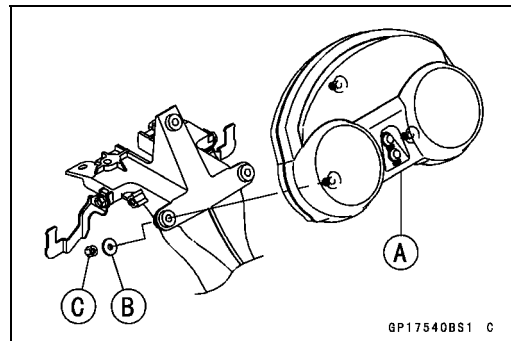

- Install:
 - Meter Lead Connector
 - Vehicle-down Sensor Bracket (as shown) and Bolt [A]
 - Immobilizer Amplifier Bracket and Bolt (Equipped Models)
 - Immobilizer Amplifier [B] (Equipped Models)
 - Windshield (see Windshield Installation in the Frame chapter)

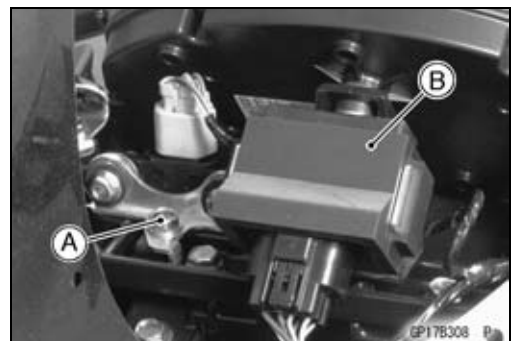

Meter, Gauge, Indicator Unit

Meter Unit Disassembly

- Remove:
 - Meter Unit (see Meter Unit Removal)
 - Screws [A]
 - Lower Meter Cover [B]

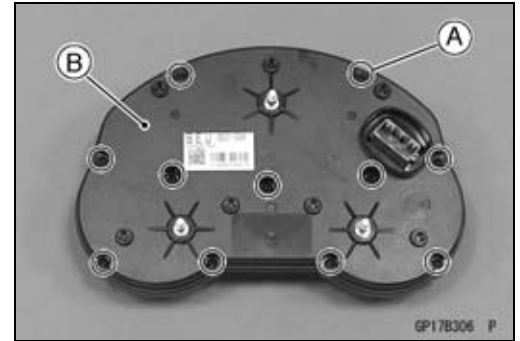

- Separate:
 - Upper Meter Cover [A]
 - Middle Meter Cover [B]
 - Meter Assembly [C]

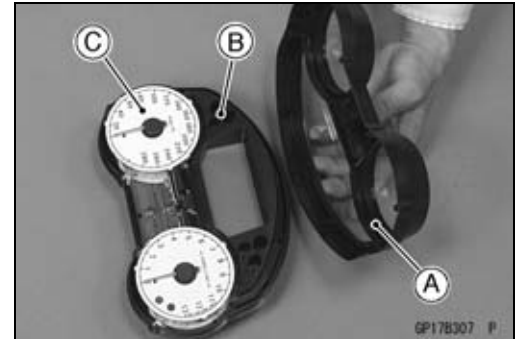

Meter Unit Inspection

- Remove the meter unit (see Meter Unit Removal).
 - [1] High Beam Indicator Light (LED)
 - [2] Oil Pressure Warning Indicator Light (LED) (-)
 - [3] Right Turn Signal Indicator Light (LED) (+)
 - [4] Neutral Indicator Light (LED) (-)
 - [5] Unused
 - [6] ABS Indicator Light (LED) (-)
 - [7] Unused
 - [8] Unused
 - [9] Ignition (+)
 - [10] Battery (+)
 - [11] Speed Sensor Supply Voltage (+)
 - [12] Ground (-)
 - [13] Speed Sensor Signal
 - [14] Unused
 - [15] Fuel Reserve Switch
 - [16] Fuel Level Sensor
 - [17] CAN Communication Line (High)
 - [18] CAN Communication Line (Low)
 - [19] Left Turn Signal Indicator Light (LED) (+)
 - [20] Unused

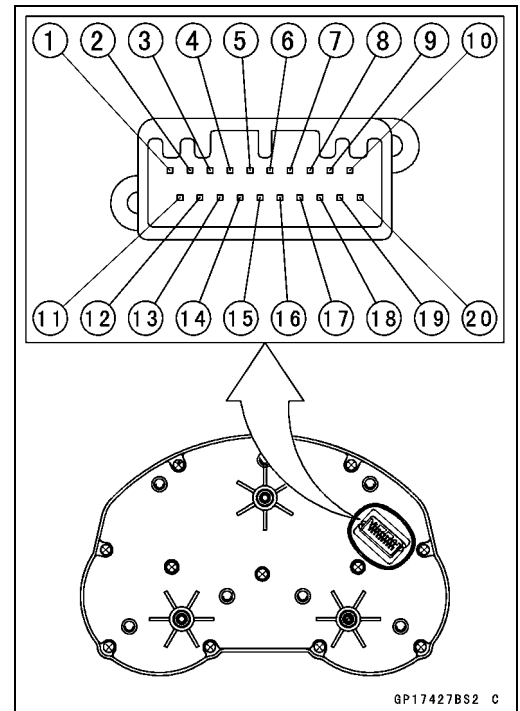

CAUTION

Do not drop the meter unit. Place the meter unit so that it faces upward. If the meter assembly is left upside down or sideways for a long time or dropped, it will malfunction. Do not short each terminals.

16-64 ELECTRICAL SYSTEM

Meter, Gauge, Indicator Unit

Check 1: CAN Communication Line Resistance Inspection

- Set the hand tester [A] to the $\times 1 \Omega$ range and connect it to the terminal [17] and [18] in the meter unit.

Special Tool - Hand Tester: 57001-1394

CAN Communication Line Resistance (at Meter Unit)

Standard: 122 ~ 126 Ω

- ★ If the tester reading is not specified, replace the meter assembly.

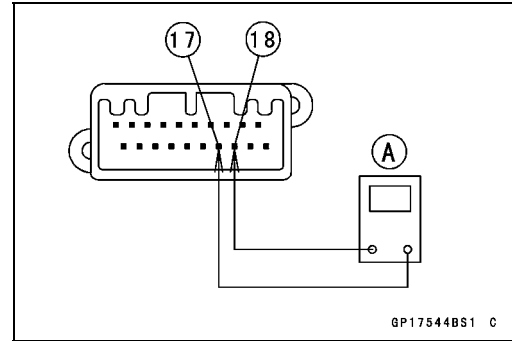

Check 2: Meter Unit Primary Operation Check

- Using the auxiliary leads, the 12 V battery [A] to the meter unit connector as follows.

- Connect the battery positive (+) terminal to the terminal [10].
- Connect the battery negative (-) terminal to the terminal [12].

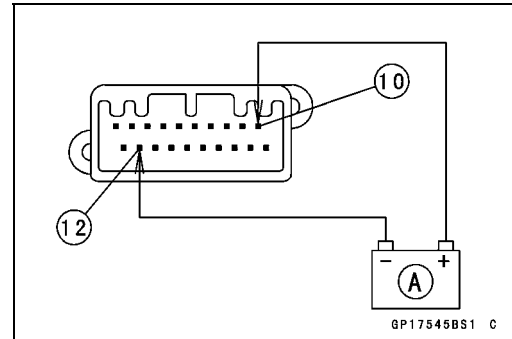

- Check that the speedometer and tachometer needles [A] momentarily point their last readings and back to the minimum position.

- ★ If the meter unit does not work, replace the meter assembly.

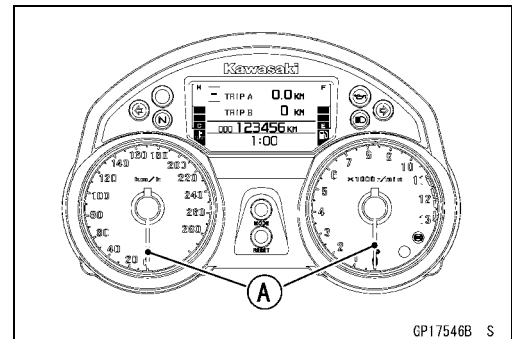

- Connect terminal [9] to the battery (+) terminal.

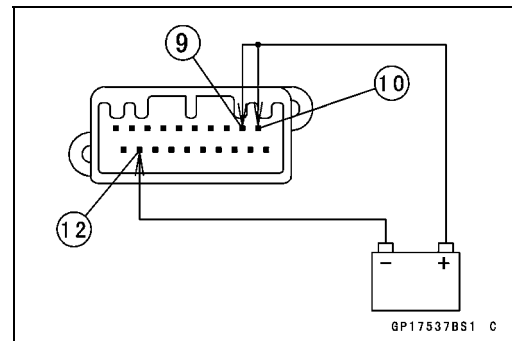

- Check that the following items.

- The speedometer and tachometer needles momentarily point their last readings and back to the minimum position.
- The ABS indicator light (LED) [A] (equipped models) should go on.
- The K Kawasaki mark [B] in the LCD appears for three seconds.

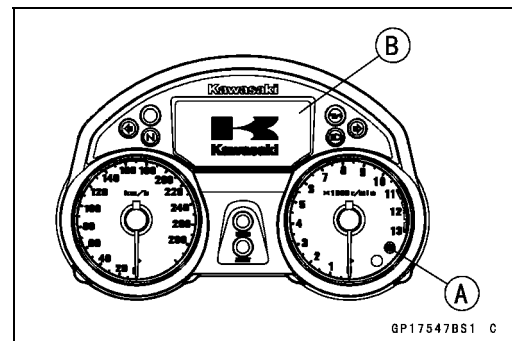

Meter, Gauge, Indicator Unit

- After the K Kawasaki mark appeared, the TRIP A/B meter [A], water temperature gauge [B], fuel level gauge [C], odometer and clock appear in the display [D].
- The ABS indicator light (LED) [E] (equipped models) should go on.
- ★ If the meter unit does not work, replace the meter assembly.

NOTE

- The flashings of the three segments for the water temperature gauge and fuel level gauge do not failure of the meter unit.
- Currently, for the meter is disconnected from the main harness each flashing occur.
- The flashing of water temperature gauge is communication error to the ECU.
- The flashing of the fuel level gauge is open or short of the fuel reserve switch.
- Normally, each flashing disappears when the meter unit is connected to main harness.

Check 3: MODE and RESET Button Operation Check

- Connect the leads in the same circuit as Check 2.
- By pushing the MODE button [A] each time, check that the display [B] changes as follows.
- This display is ordinary indication.



GP17543BN3 C

- ★ If the display function does not work, replace the meter assembly.
- Push the MODE button [A] and RESET button [B] for more than two seconds.

- Check that the display changes to the language setting mode [A].
- This display is system menu indication.
- By pushing the RESET button each time, check that the display selects the ENGLISH or FRANCAIS.
- ★ If the display function does not work, replace the meter assembly.

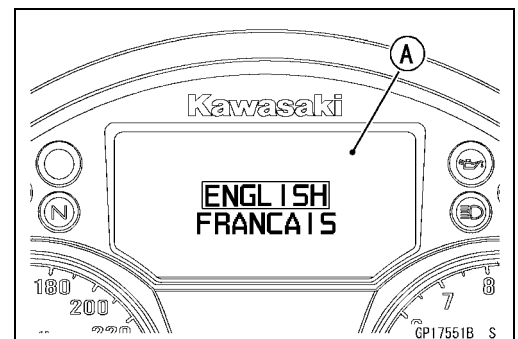
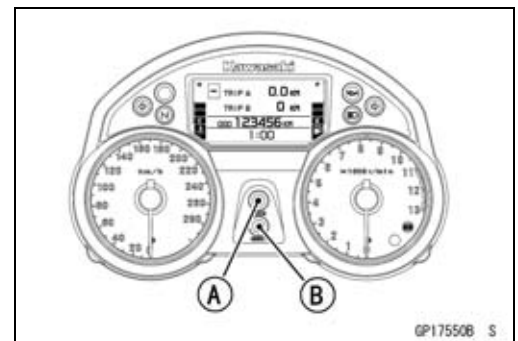
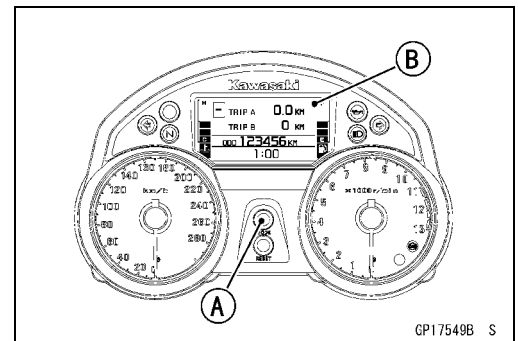
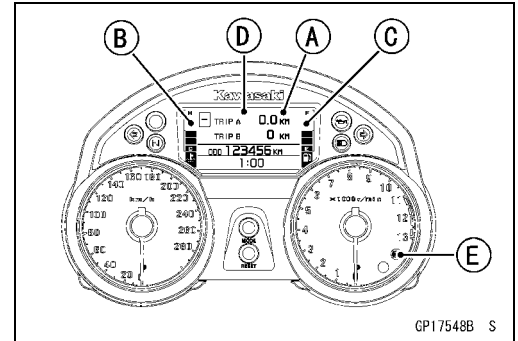

16-66 ELECTRICAL SYSTEM

Meter, Gauge, Indicator Unit

- By pushing the MODE button each time at the language setting mode, check that the display [A] selects as follows.

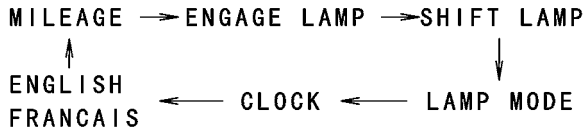

GP17554BN3 C

- ★ If the display function does not work, replace the meter assembly.

- Select the MILEAGE [A] indication.
- Push the MODE button for more than two seconds, check that the unit setting menu [B] flashes.
- By pushing the RESET button each time, check that the display changes as follows.

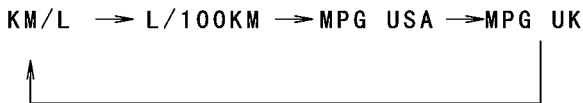

GP17555BN3 C

- Check that the unit setting menu is decided by the MODE button push.
- ★ If the display function does not work, replace the meter assembly.

- Select the ENGAGE LAMP [A] indication.
- Push the MODE button for more than two seconds, check that the engine speed setting menu [B] flashes.
- By pushing the RESET button each time, check that the display changes as follows.

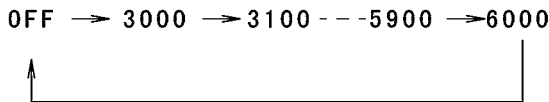

GP17556BN3 C

- Check that the engine speed setting menu is decided by the MODE button pushing.
- ★ If the display function does not work, replace the meter assembly.

- Select the SHIFT LAMP [A] indication.
- Push the MODE button for more than two seconds, check that the engine speed setting menu [B] flashes.
- By pushing the RESET button each time, check that the display changes as follows.

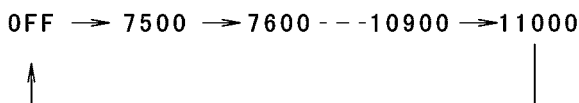

GP17557BN3 C

- Check that the engine speed setting menu is decided by the MODE button pushing.
- ★ If the display function does not work, replace the meter assembly.

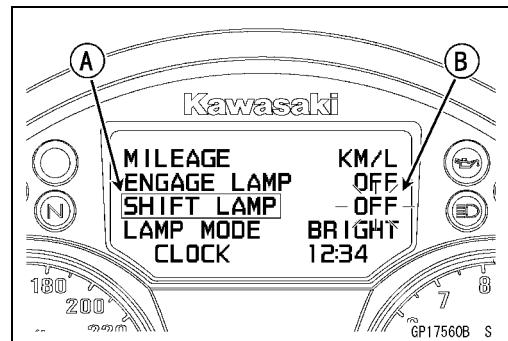
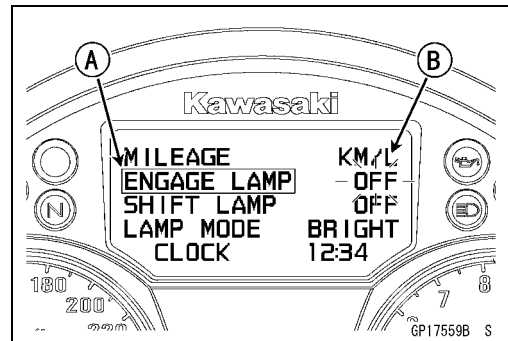
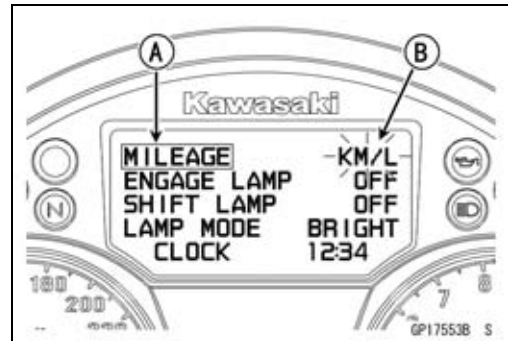
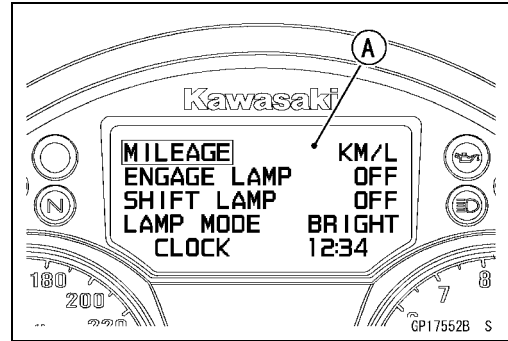

Meter, Gauge, Indicator Unit

- Select the LAMP MODE [A] indication.
- Push the MODE button for more than two seconds, check that the lighting mode setting menu [B] flashes.
- By pushing the RESET button [C] each time, check that the display changes as follows and the indicator light (LED) [D] goes on according to message.



GP17558BN3 C

- Check that the lighting mode setting menu is decided by the MODE button pushing.
- ★ If the display function does not work, replace the meter assembly.

- Select the CLOCK [A] indication.
- Push the MODE button for more than two seconds.
- The clock setting menu (hour and minute) [B] should flash.

- Push the RESET button.
- The hour display [A] starts flashing.
- By pushing the MODE button each time, check that the hour display changes.

- By pushing the RESET button, check that the hour display decide and minute display [A] starts flashing.
- By pushing the MODE button each time, check that the minute display changes.

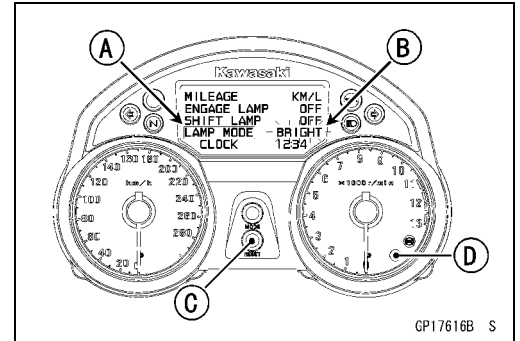

GP17616B S

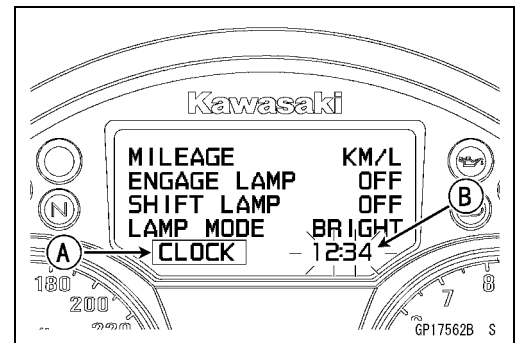

GP17562B S

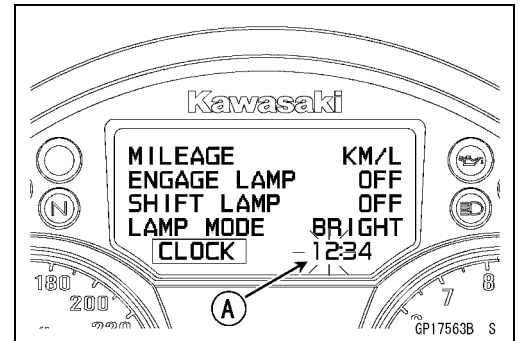

GP17563B S

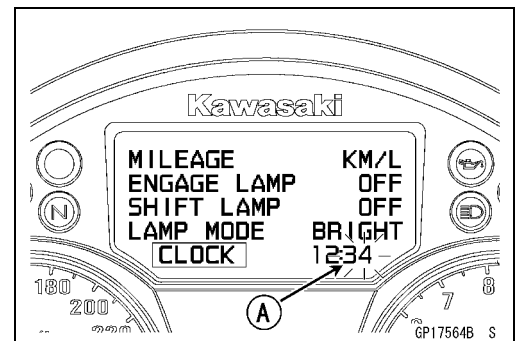

GP17564B S

16-68 ELECTRICAL SYSTEM

Meter, Gauge, Indicator Unit

- By pushing the RESET button, check that the hour and minute display [A] starts flashing.
- By pushing the MODE button, check that the hour and minute display decide.
- When both hour and minute display flashing, by pushing the RESET button, check that the hour display start flashing. This flashing returns the hour setting mode.
- ★ If the display function does not work, replace the meter assembly.

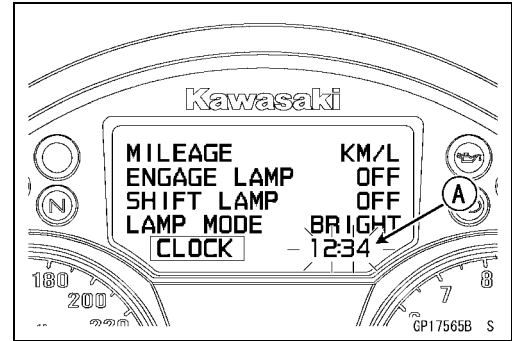

Check 4: Battery Voltage Inspection

- Connect the leads in the same circuit as Check 2.

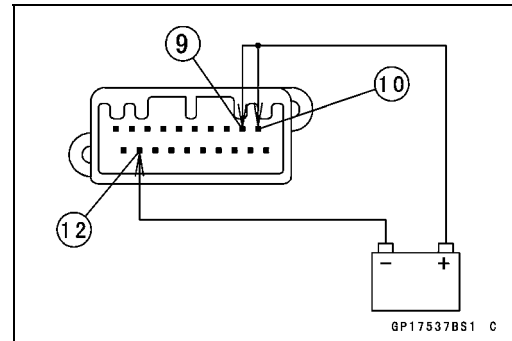

- 1st, set the BATTERY display.
- Check that the display indicates the battery voltage.

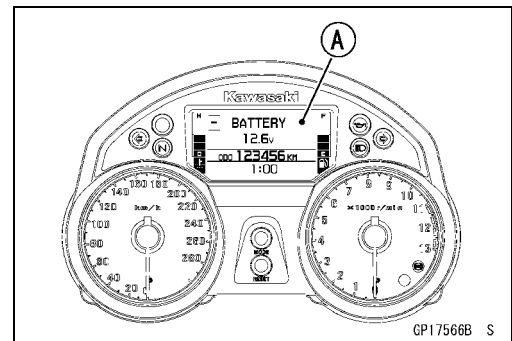

- 2nd, disconnect the terminal [10].
- Check that the display changes 9.0 V within about 30 seconds.

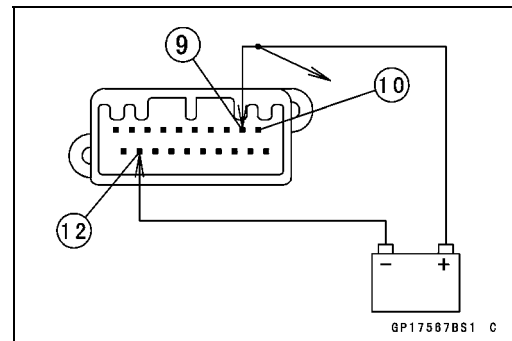

- 3rd, connect the terminal [10].
 - Check that the display changes the current battery voltage within about 30 seconds.
- The tolerance of the voltage is ± 0.4 V.
- ★ If the display function does not work, replace the meter assembly.

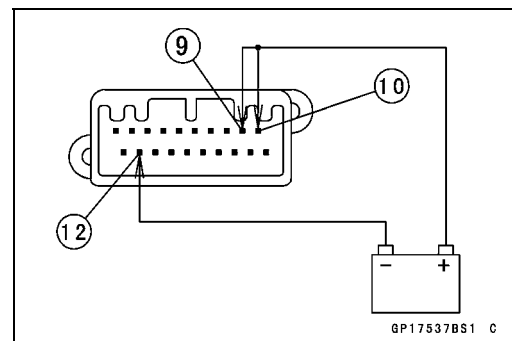

Meter, Gauge, Indicator Unit

Check 5: Immobilizer Flashing Mode Inspection (Equipped Models)

- Connect the leads in the same circuit as Check 2.
- Disconnect the terminal [9].

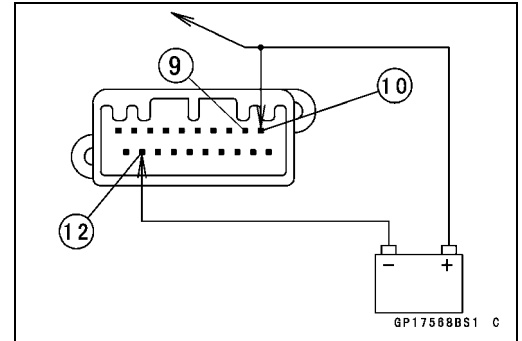

- Check that the warning light (LED) [A] starts flashing (Immobilizer Warning Light Flashing Mode).
- Push the MODE [B] and RESET [C] buttons more than 2 second, within 20 seconds after the terminal [9] disconnected.
- Check that the warning light (LED) goes on one second, and then the light goes off (Immobilizer Warning Light No Flashing Mode).

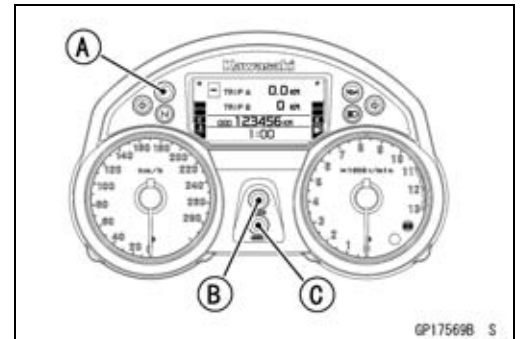

NOTE

○For this inspection, be sure the battery is 12.4 V or more. Immobilizer Warning Light Flashing Mode does not work, when the battery voltage is less than 12 ± 0.4 V.

- Connect the terminal [9] to the battery (+) terminal.
 - And then, disconnect the terminal [9].
 - Push the MODE and RESET buttons more than 2 second, within 20 seconds after the terminal [9] disconnected.
 - Check that the warning light (LED) goes on one second, and then the light starts flashing (Immobilizer Warning Light Flashing Mode).
- ★If the meter function does not work, replace the meter assembly.

Check 6: High Beam Indicator Light (LED) Inspection

- Connect the leads in the same circuit as Check 2.
- Connect the terminal [1] to the battery (+) terminal.

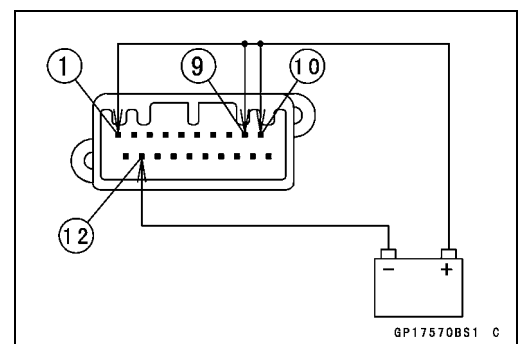

16-70 ELECTRICAL SYSTEM

Meter, Gauge, Indicator Unit

- Check that the high beam indicator light (LED) [A] goes on.
- ★ If the indicator light does not go on, replace the meter assembly.

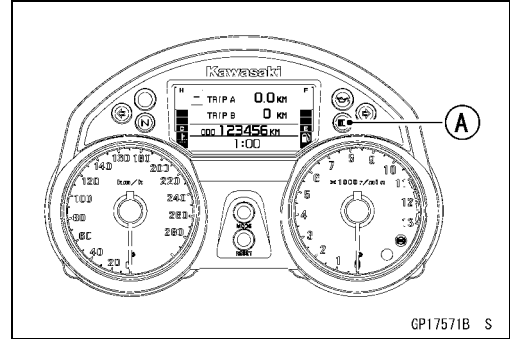

Check 7: Right Turn Signal Indicator Light (LED) Inspection

- Connect the leads in the same circuit as Check 2.
- Connect the terminal [3] to the battery (+) terminal.

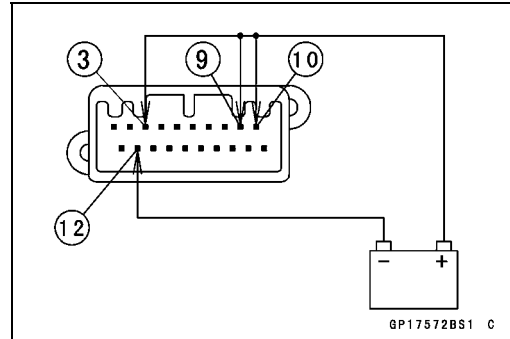

- Check that the right turn signal indicator light (LED) [A] goes on.
- ★ If the indicator light does not go on, replace the meter assembly.

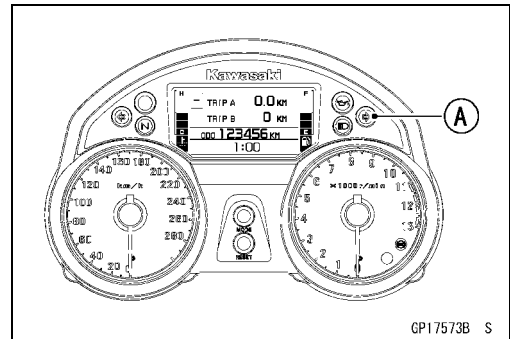

Check 8: Left Turn Signal Indicator Light (LED) Inspection

- Connect the leads in the same circuit as Check 2.
- Connect the terminal [19] to the battery (+) terminal.

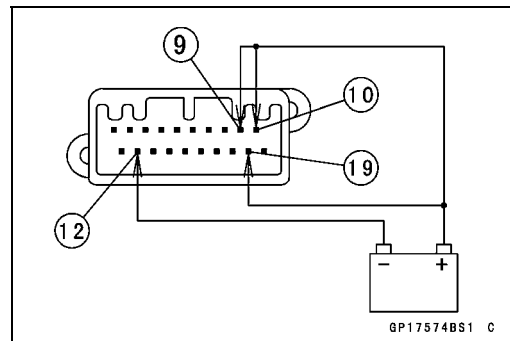

- Check that the left turn signal indicator light (LED) [A] goes on.
- ★ If the indicator light does not go on, replace the meter assembly.

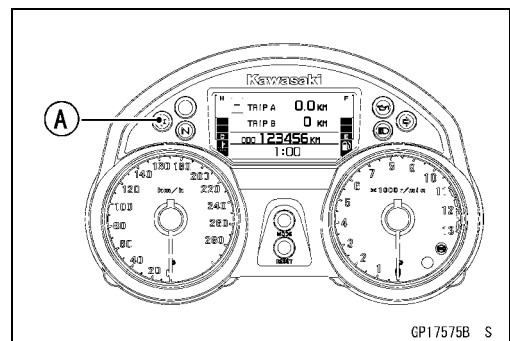

Meter, Gauge, Indicator Unit

Check 9: Oil Pressure Warning Indicator Light (LED) Inspection

- Connect the leads in the same circuit as Check 2.
- Connect the terminal [2] to the battery (-) terminal.

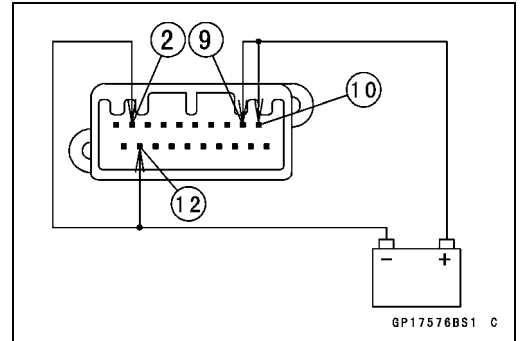

- Check that the oil pressure warning indicator light (LED) goes on.
- ★ If the indicator light does not go on, replace the meter assembly.

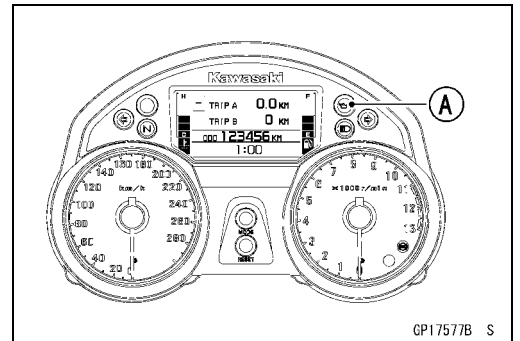

Check 10: Neutral Indicator Light (LED) Inspection

- Connect the leads in the same circuit as Check 2.
- Connect the terminal [4] to the battery (-) terminal.

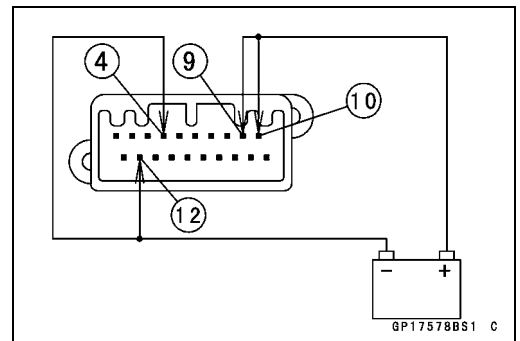

- Check that the neutral indicator light (LED) goes on.
- ★ If the indicator light does not go on, replace the meter assembly.

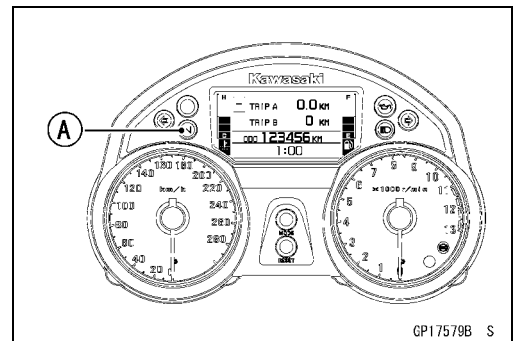

Check 11: ABS Indicator Light (LED) Inspection (Equipped Models)

- Connect the leads in the same circuit as Check 2.
- Check that the ABS indicator light (LED) [A] goes on.

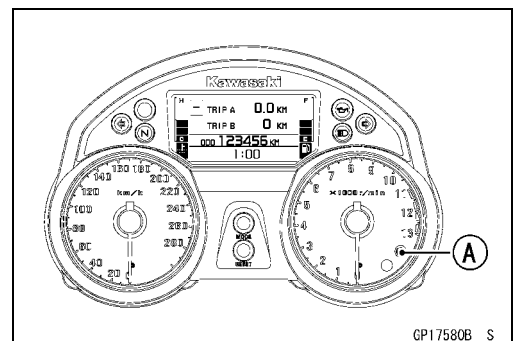

16-72 ELECTRICAL SYSTEM

Meter, Gauge, Indicator Unit

- Connect the terminal [6] to the battery (-) terminal.
- Check that the ABS indicator light (LED) goes off.
- ★ If the indicator light does not go on, replace the meter assembly.

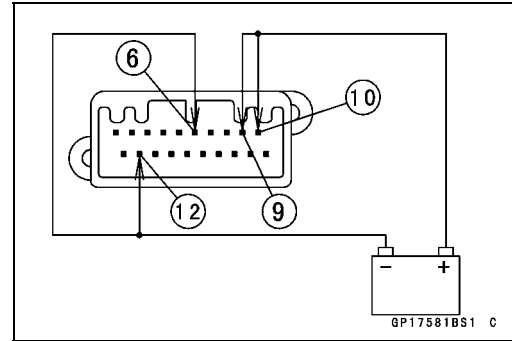

Check 12: Fuel Level Warning Inspection

- Connect the leads in the same circuit as Check 2.
- Connect the variable rheostat [A] (about 22 Ω) to the terminal [15] and the battery (-) terminal.

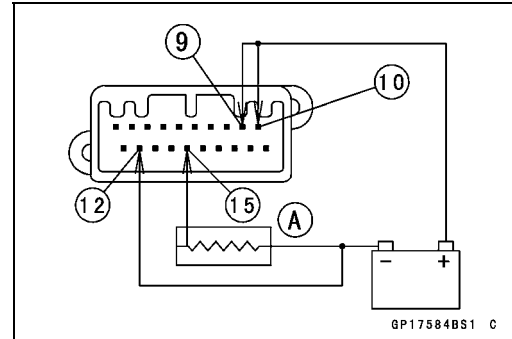

- After about 5 seconds, check that one segment [A] in the fuel gauge starts flashing.
- Check that the FUEL EMPTY [B] and fuel symbol [C] appear alternately in the display.
- ★ If the display function does not work, replace the meter assembly.
- This display is the warning message indication.

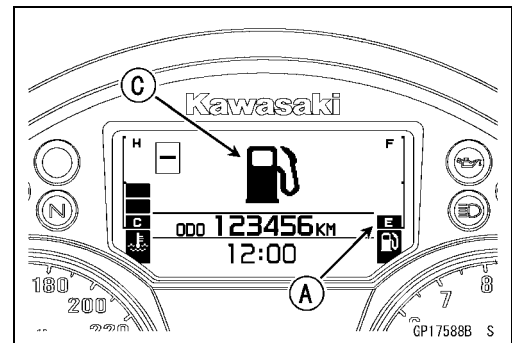
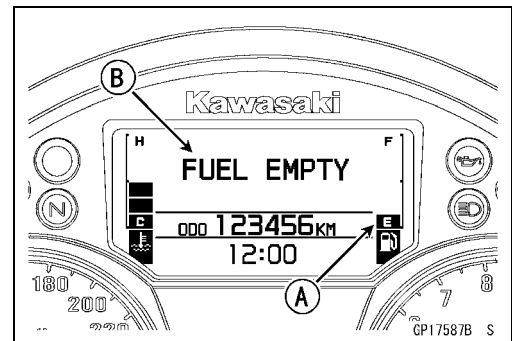

- Push the MODE button [A] more than 2 seconds.
- Check that the warning light (LED) [B] goes on and display changes TRIP A/B meter [C] mode.
- The one segment [D] in the fuel gauge keeps flashing.
- Push the MODE button more than 2 seconds.
- Check that the warning light (LED) goes off and display changes the warning message indication mode.
- The one segment in the fuel gauge keeps flashing.
- ★ If the display function does not work, replace the meter assembly.
- Disconnect the battery to disappear the warning message indication.

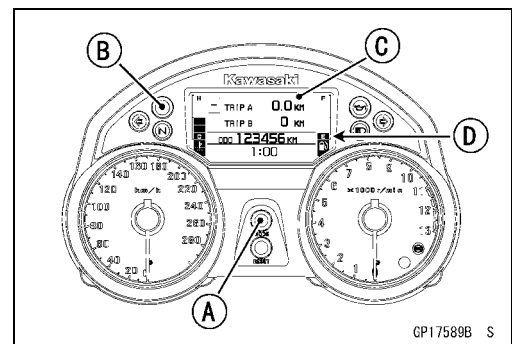

Meter, Gauge, Indicator Unit

Check 13: Fuel Gauge Inspection

- Connect the leads in the same circuit as Check 2.
- Connect the resistor [A] (about 1 kΩ) to the terminal [15] and the battery (-) terminal.
- Connect the variable rheostat [B] to the terminal [16] and the battery (-) terminal.
- Check that the number of segments matches the resistance value of the variable rheostat.
- When the terminal [16] is connected, one segment in the fuel level gauge should appear about every 15 seconds.

Variable Rheostat Resistance (Ω)	Display Segments [A]
10	6
200	1

★ If the display function does not work, replace the meter assembly.

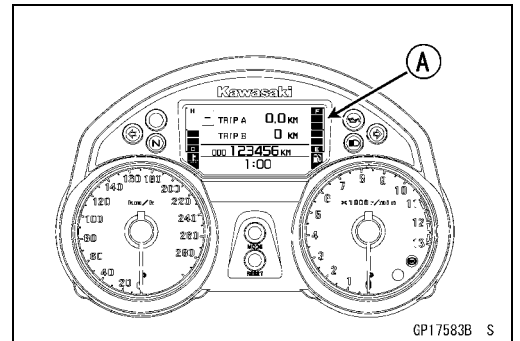
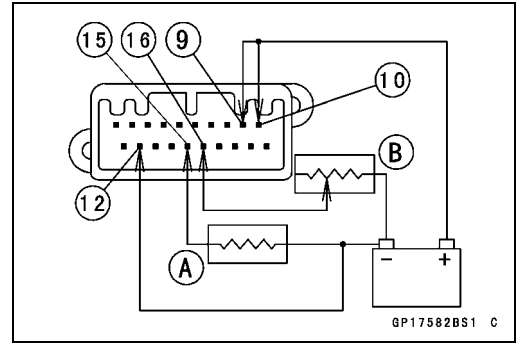

Check 14: Speedometer Inspection

- Connect the leads in the same circuit as Check 2.
- The speed equivalent to the input frequency is indicated in the oscillator [A], if the square wave is input into terminal [13].
- Indicates approximately 60 mph if the input frequency is approximately 131.2 Hz.
- Indicates approximately 60 km/h if the input frequency is approximately 82 Hz.
- ★ If the meter function does not work, replace the meter assembly.

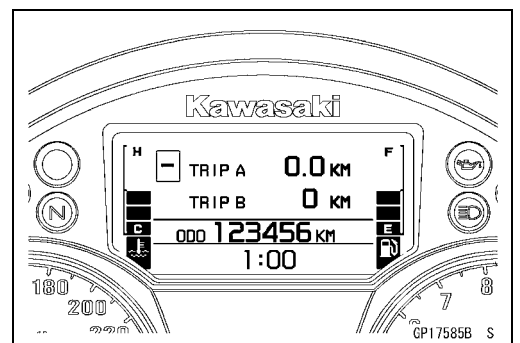
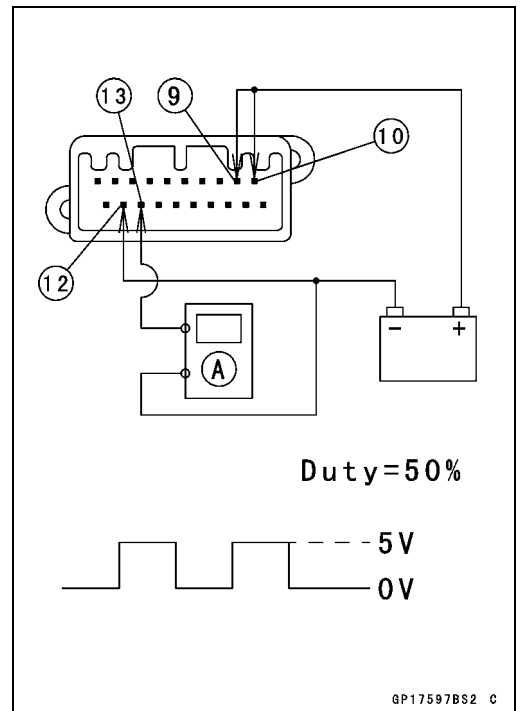

Check 15: Trip A/B Meter Inspection

- Connect the leads in the same circuit as Check 14.
- Set the TRIP A/B meter mode in the display.
- Raise the input frequency of the oscillator to see the result of this inspection.
- ★ If the value indicated by the trip meter A/B do not increase, replace the meter assembly.

16-74 ELECTRICAL SYSTEM

Meter, Gauge, Indicator Unit

- By pushing the RESET button each time, check that the display starts flashing as follows.

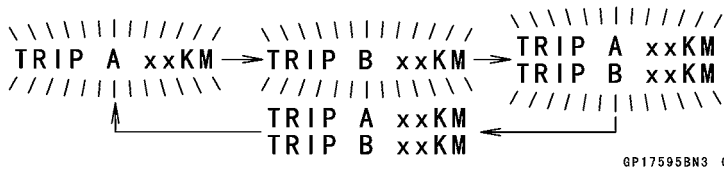

- When flashing the display, push the RESET button for more than two seconds, check that the display changes 0.0 (TRIP A) and 0 (TRIP B).
- ★ If the display function does not change, replace the meter assembly.

Check 16: Odometer Inspection

- Connect the leads in the same circuit as Check 14.
- Raise the input frequency of the oscillator to see the result of odometer [A] inspection.
- Example: Indicates the increase of approximately 1 mile, if the input frequency is approximately 131.2 Hz for one minute.
- Example: Indicates the increase of approximately 1 km/h, if the input frequency is approximately 82 Hz for one minute.
- ★ If the value indicated by the odometer does not increase, replace the meter assembly.

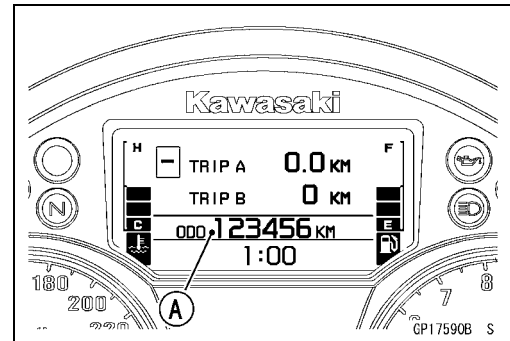

Check 17: Speed Sensor Supply Voltage Inspection

- Connect the leads in the same circuit as Check 2.
- Set the hand tester to the 25 V range and connect it in the meter unit as follows.

Special Tool - Hand Tester: 57001-1394

Connections:

- Hand Tester (+) → Terminal [11]
- Hand Tester (-) → Terminal [12]

Speed Sensor Supply Voltage
Standard: about 12 V

- ★ If the tester reading is not specified, replace the meter assembly.

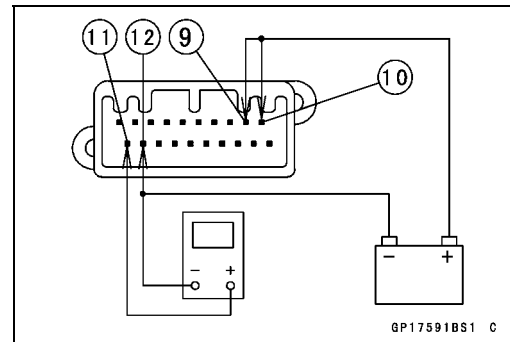

Meter, Gauge, Indicator Unit

Check 18: Water Temperature Gauge Inspection

- Connect the leads in the same circuit as Check 2.
- Connect the CAN communication lines from meter connector [A] to main harness connector [B] as shown.

Connections:

Meter Terminal [17] → Main Harness Terminal [17]

Meter Terminal [18] → Main Harness Terminal [18]

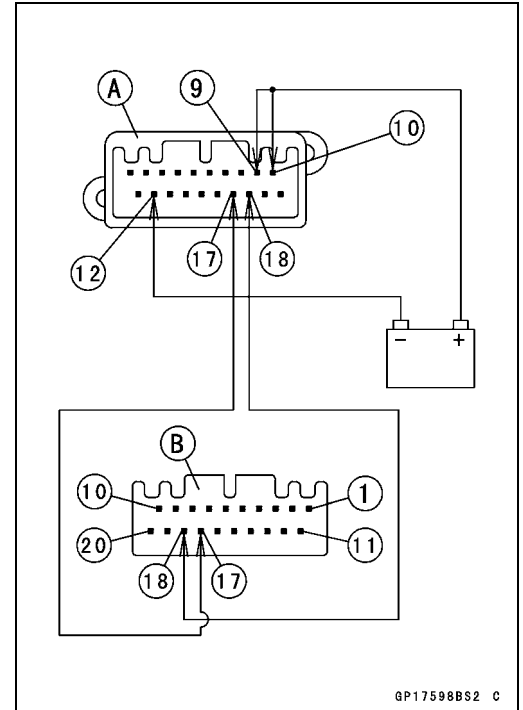

- Turn the ignition switch ON.
- Check that the only symbol [A] appears in the water temperature gauge.
- Turn the ignition switch OFF.
- ★ If the display function does not work, go to the Check 1 and check the following items.

Wiring (see Wiring Inspection)

CAN Communication Line Resistance (at ECU) (see CAN Communication Line Resistance Inspection in the Fuel System (DFI) chapter)

Water Temperature Sensor (see Water Temperature Sensor (Service Code 14) section in the Fuel System (DFI) chapter)

- ★ If the above items are good, replace the meter assembly and/or ECU.

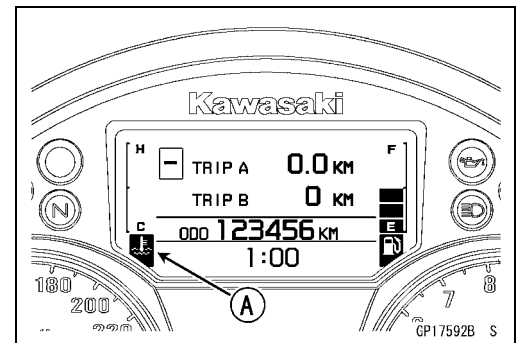

Check 19: FI/IMMOBILIZER Error Inspection

- Connect the leads in the same circuit as Check 18.
- For example, disconnect the atmospheric pressure sensor [A].
- Install the key registration unit [B] (see Key Registration) (Immobilizer equipped model).

Special Tool - Key Registration Unit: 57001-1582

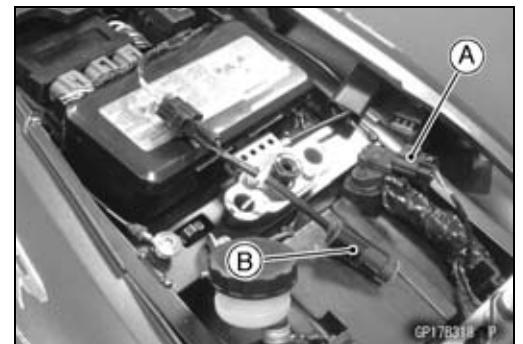

16-76 ELECTRICAL SYSTEM

Meter, Gauge, Indicator Unit

- Turn the ignition switch ON by the current key.
- Check that the warning light (LED) [A] starts flashing and the display [B] changes as follows.

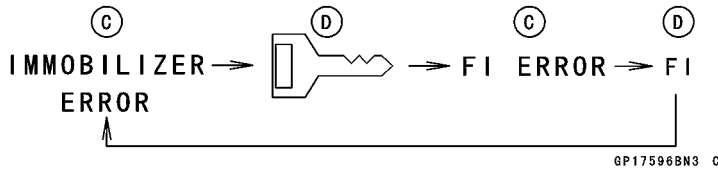

[C] Warning Message

[D] Symbol

- This display is the warning message indication.
- ★ If the display function does not work, go to the Check 1 and check the following items.
 - Wiring (see Wiring Inspection)
 - CAN Communication Line Resistance (at ECU) (see CAN Communication Line Resistance Inspection in the Fuel System (DFI) chapter)

Example:

Immobilizer System (see Immobilizer Amplifier and Blank Key Detection section in the Fuel System (DFI) chapter)

Atmospheric Pressure Sensor (see Atmospheric Pressure Sensor (Service Code 15) section in the Fuel System (DFI) chapter)

- Refer to Troubleshooting the DFI System section in the Fuel System (DFI) chapter for other DFI parts
- ★ If the above items are good, replace the meter assembly and/or ECU.

- By pushing the MODE button [A] each time, check that the display changes the error messages [B] only.
- During this operating, the symbols do not appear.
- The warning indicator light (LED) keeps flashing.

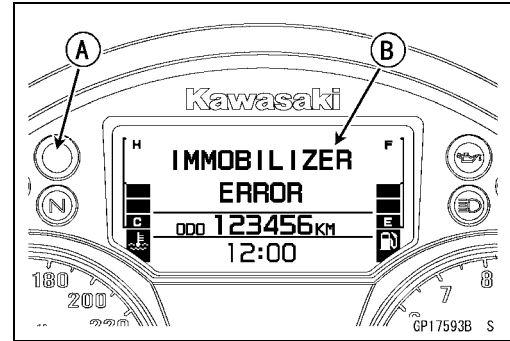

- Push the MODE and RESET buttons for more than two seconds, check that each ERROR CODE [A] and numbers appears in the display.
- The warning indicator light (LED) keeps flashing.
- Again, push the MODE and RESET buttons for more than two seconds, check that the display returns the warning message indication.
- The warning indicator light (LED) keeps flashing.
- ★ If the display function does not work, replace the meter assembly.

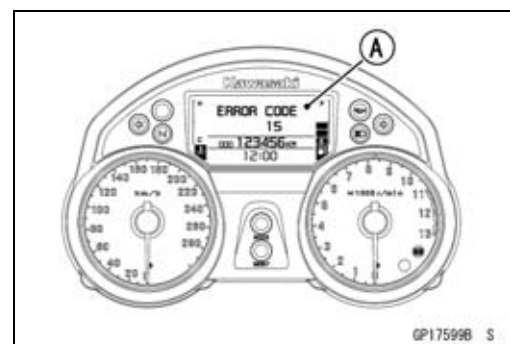
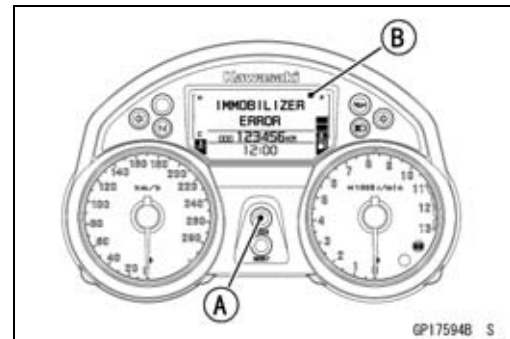

Meter, Gauge, Indicator Unit

Check 20: Tachometer Inspection

- Connect the leads in the same circuit as Check 18.
- Confirm the vehicle down sensor is correct position.
- Start the engine.
- Check that the needle [A] in the tachometer moves.
- ★ If the needle does not move, go to the Check 1 and inspect the following items.
 - Wiring (see Wiring Inspection)
 - CAN Communication Line Resistance (at ECU) (see CAN Communication Line Resistance Inspection in the Fuel System (DFI) chapter)
 - Crankshaft Sensor (see Crankshaft Sensor Inspection)
- ★ If the above items are good, replace the meter assembly and/or ECU.

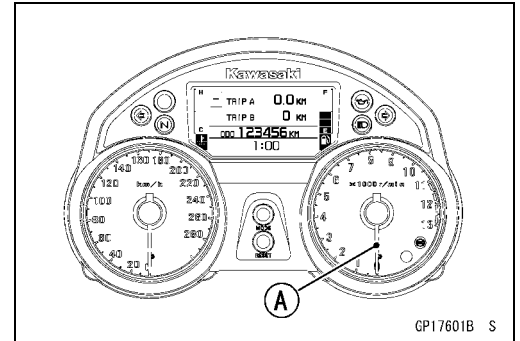

Check 21: Gear Position Indication Inspection

- Install the meter unit (see Meter Unit Installation).
- Turn the ignition switch ON.
- Check that the N mark [A] appears in the display and neutral indicator light (LED) [B] goes on.
- Set the low gear position, check that the display changes to 1 mark.
- For the other gear position indication;
- Using the stand, raise the rear wheel off the ground (see Interlock Operation Inspection).
- Start the engine, change the gear position.
- Check that the display corresponding to each gear position appears.
- Turn the ignition switch OFF.
- ★ If the display function does not work, go to the Check 1 and check the following items.
 - Wiring (see Wiring Inspection)
 - CAN Communication Line Resistance (at ECU) (see CAN Communication Line Resistance Inspection in the Fuel System (DFI) chapter)
 - Gear Position Switch (see Gear Position Switch (Service Code 25) section in the Fuel System (DFI) chapter)
 - Speed Sensor (see Speed Sensor (Service Code 24) section in the Fuel System (DFI) chapter)
- ★ If the above items are good, replace the meter assembly and/or ECU.

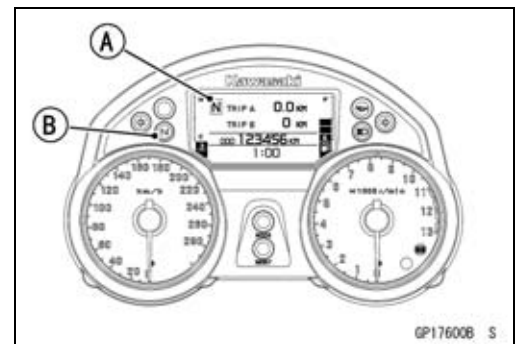

16-78 ELECTRICAL SYSTEM

Meter, Gauge, Indicator Unit

Check 22: Other Inspection

- The following items are displayed while running.
 - AVERAGE
 - INST
 - RANGE
 - Engage Lamp/Shift Lamp Indication
- When the above item is faulty indication check the following items.
 - Wiring (see Wiring Inspection)
 - CAN Communication Line Resistance (see Check 1 and CAN Communication Line Resistance Inspection in the Fuel System (DFI) chapter)
 - Fuel Injectors (see Fuel Injectors (Service Code 41, 42, 43, 44) section in the Fuel System (DFI) chapter)
 - Speed Sensor (see Speed Sensor (Service Code 24) section in the Fuel System (DFI) chapter)
 - Crankshaft Sensor (see Crankshaft Sensor Inspection)
 - Fuel Level Sensor (see Fuel Level Sensor Inspection)
 - Fuel Reserve Switch (see Fuel Reserve Switch Inspection)
- ★ If the above items are good, replace the meter assembly and/or ECU.

Meter, Gauge, Indicator Unit

Meter Unit Circuit

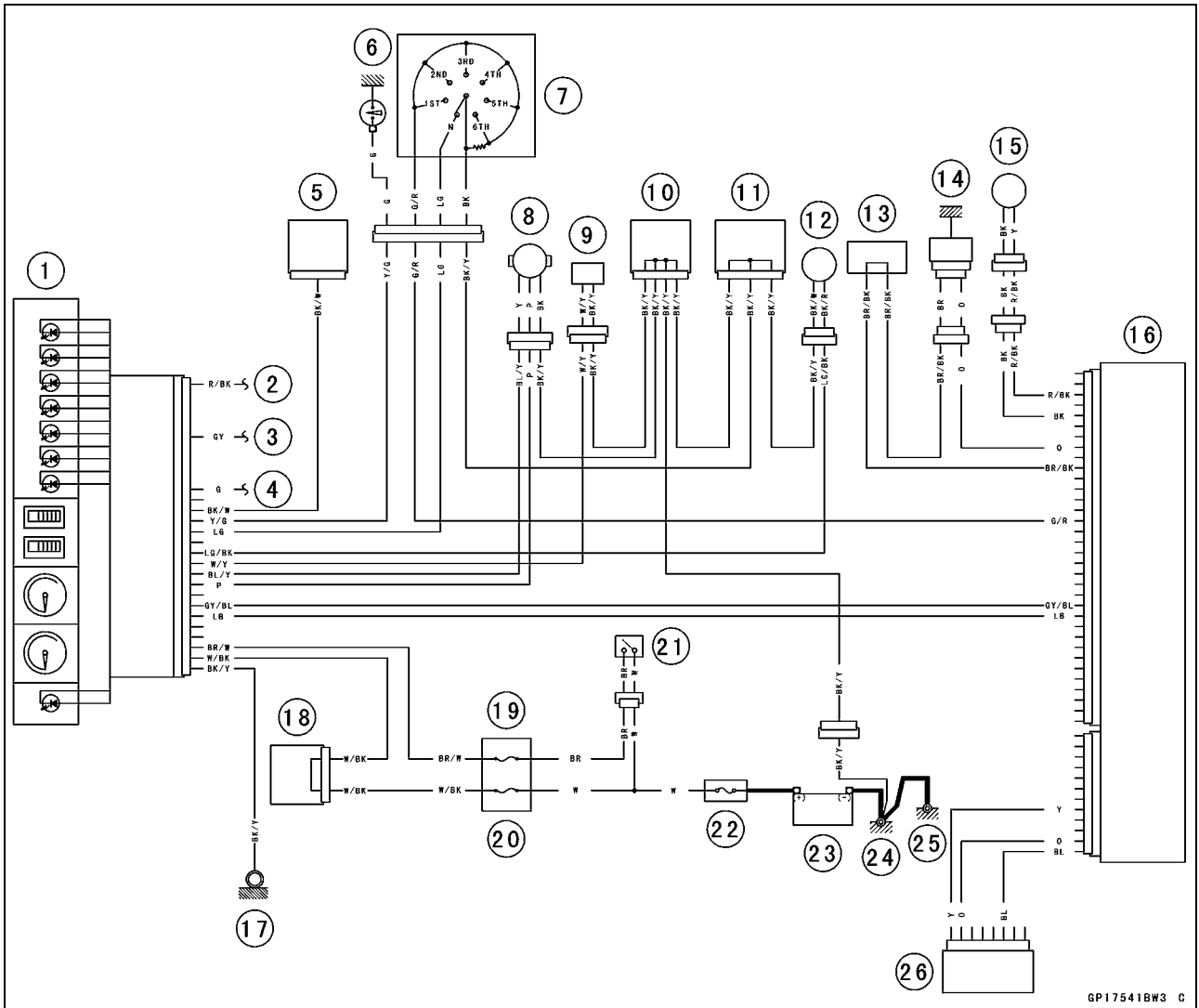

- | | |
|---|---|
| <ul style="list-style-type: none"> 1. Meter Unit 2. Dimmer Switch (High Beam) 3. Turn Signal Switch (Right) 4. Turn Signal Switch (Left) 5. ABS Hydraulic Unit (Equipped Models) 6. Oil Pressure Switch 7. Gear Position Switch 8. Speed Sensor 9. Fuel Level Sensor 10. Joint Connector 1 11. Joint Connector 2 12. Fuel Reserve Switch 13. Water-proof Joint 2 | <ul style="list-style-type: none"> 14. Water Temperature Sensor 15. Crankshaft Sensor 16. ECU 17. Frame Ground 1 18. Water-proof Joint 1 19. Ignition Fuse 10 A (in Fuse Box 2) 20. ECU Fuse 15 A (in Fuse Box 2) 21. Ignition Switch 22. Main Fuse 30 A 23. Battery 12 V 14 Ah 24. Frame Ground 2 25. Engine Ground 26. Immobilizer Amplifier (Equipped Models) |
|---|---|

16-80 ELECTRICAL SYSTEM

Immobilizer System (Equipped Models)

This motorcycle is equipped with an immobilizer system to protect the motorcycle from theft. This system provides a theft proof device by means of matching a code between the inbuilt key transponder and ECU (Electronic Control Unit). If the code does not match, ignition system, injectors, and sub-throttle valve actuator will not operate and the engine will not start.

Abstract

- Do not keep more than one immobilizer key of any system on a key ring. Jamming of the key code signal may occur and the operation of the system may be affected.
- The warning indicator light (LED) will flash for a period of 24 hours once the ignition switch has been switched off and the key removed. This flashing can be set to on or off as desired by holding the Mode and Reset buttons down for two seconds within twenty seconds of switching the ignition off.
- If all coded keys (master key and user keys) are lost the ECU and ignition switch will have to be replaced.
- The immobilizer system can not function until the master key code is registered in the ECU.
- A total of six keys can be registered in the ECU at any one time (one master key and five user keys).
- If the master key is lost it is not possible to register new user keys.

Operational Cautions

1. Do not put two keys of any immobilizer system on the same key ring.
2. Do not submerge any key in water.
3. Do not expose any key to excessively high temperature.
4. Do not place any key close to magnet.
5. Do not place a heavy item on any key.
6. Do not grind any key or alter its shape.
7. Do not disassemble the plastic part of any key.
8. Do not drop the key and/or apply any shocks to the key.
9. When a user key is lost, the user should go to his dealer to invalidate the lost key registration in the ECU.
10. When the master key is lost, the user should go to his dealer and have a new ECU installed and register a new master key and user keys.

NOTE

○No.9 and 10 are strongly recommended to the customer to ensure security of the motorcycle.

Key Registration

Case 1: When the user key has been lost or additional spare user key is required.

- Prepare a new spare user key.
- Cut the key in accordance with the shape of the current user key.
- Remove the seat (see Seat Removal in the Frame chapter).
- Disconnect the immobilizer/Kawasaki diagnostic system connector [A].
- Connect the key registration unit [A].

Special Tool - Key Registration Unit: 57001-1582

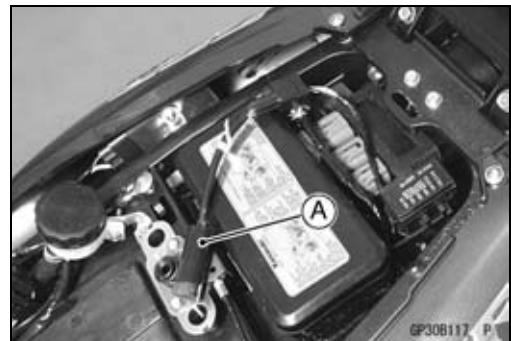

Immobilizer System (Equipped Models)

- Insert the master key to the ignition switch and turn it ON.

Verified

- The warning indicator light (LED) [A] blinks to display the registration mode (go to the next step).

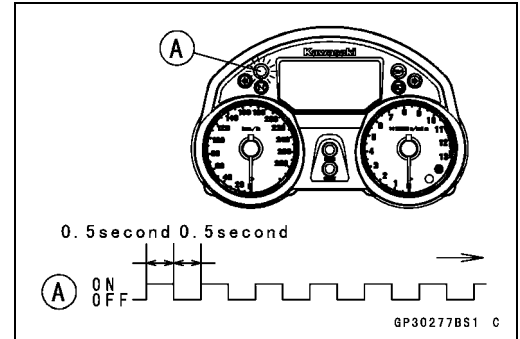

Not Verified

- The warning indicator light (LED) [A] blinks to display the collation error (refer to the following failure illustrations).
Immobilizer Amplifier Failure

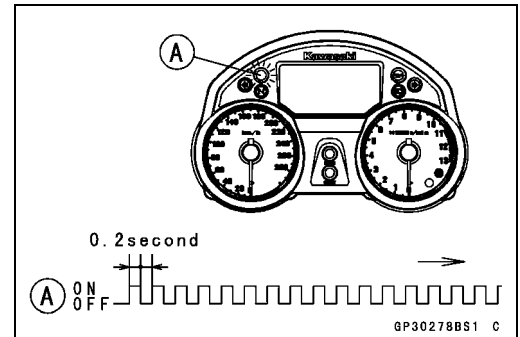

Master Key Collation Error

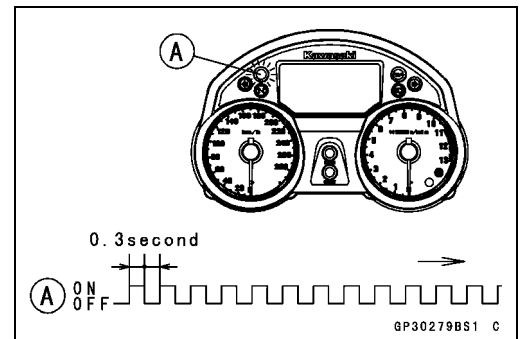

- Turn the master key OFF and remove the master key.
- The warning indicator light (LED) [A] blinks continuously to display that the ECU is in the registration mode for 15 seconds.

NOTE

- Insert next key and turn ON within 15 seconds after previous key is turned off and removed otherwise registration mode will be ended and the warning indicator light (LED) stops flashing.
- To return to the registration mode start the master key verification procedure. This applies to all user key registration.

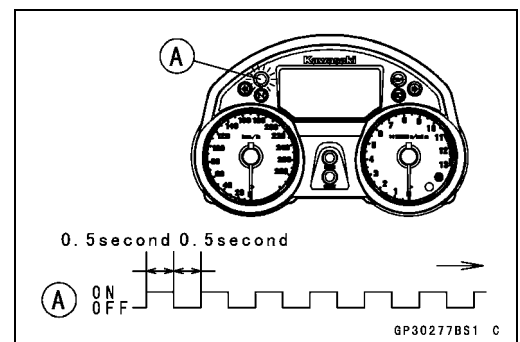

- Insert the user key 1 to the ignition switch and turn it ON.

NOTE

- Keep the other user key away from the immobilizer antenna.

16-82 ELECTRICAL SYSTEM

Immobilizer System (Equipped Models)

- If there is any problem in the registration, the warning indicator light (LED) [A] blinks to display the collation error.
Immobilizer Amplifier Failure

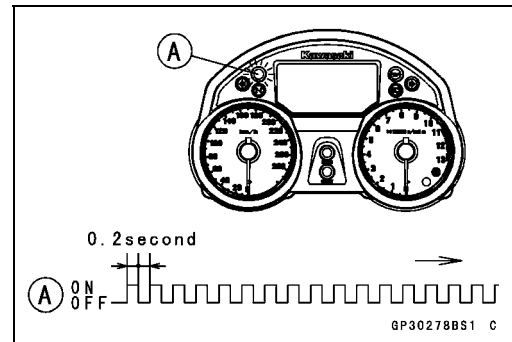

When Registered User Key is Inserted.

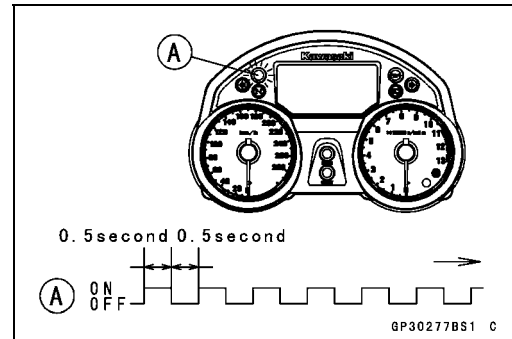

User Key Collation Error

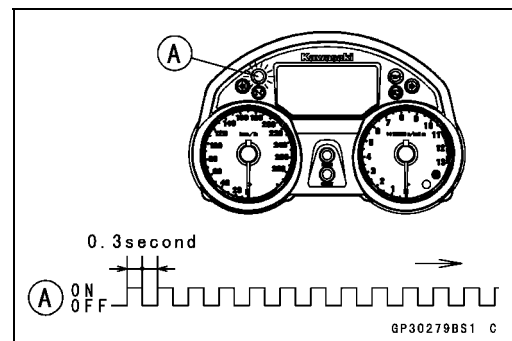

- The user key 1 is successfully registered in the ECU.
- The warning indicator light (LED) [A] blinks 2 times and stops for 1 second and then repeats this cycle.

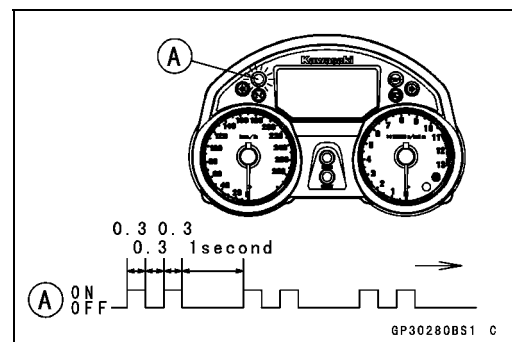

- Turn the user key 1 OFF and remove the user key 1.
- The warning indicator light (LED) [A] blinks to display the registration mode.

NOTE

- Turn off the ignition switch and wait for the period of 15 seconds or more. The registration mode automatically finishes and the warning indicator light (LED) will switch off.
- This procedure registered the master key and one user key.
- Continue with the procedure to register the second and later keys before the 15 seconds period has elapsed.
- Insert the user key 2 to the ignition switch and turn it ON.

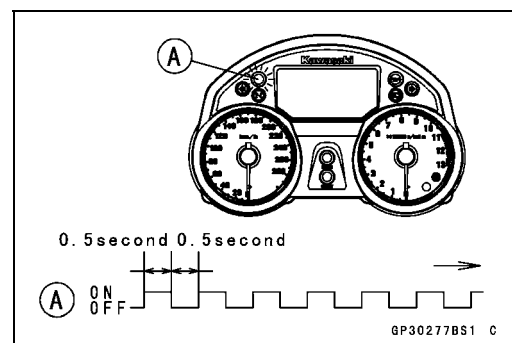

Immobilizer System (Equipped Models)

○If there is any problem in the registration, the warning indicator light [A] blinks to display the collation error.
Immobilizer Amplifier Failure

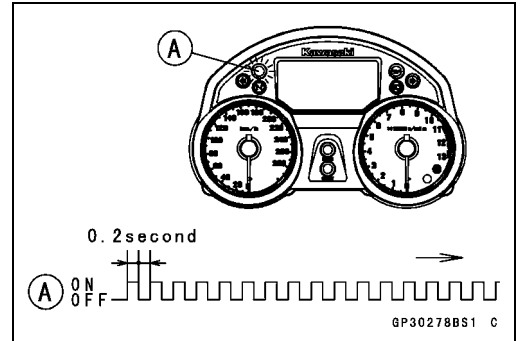

When Registered User Key is Inserted.

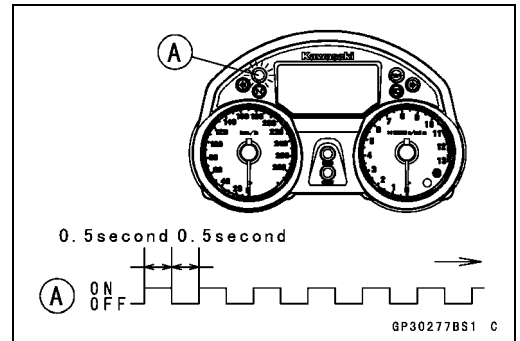

User Key Collation Error

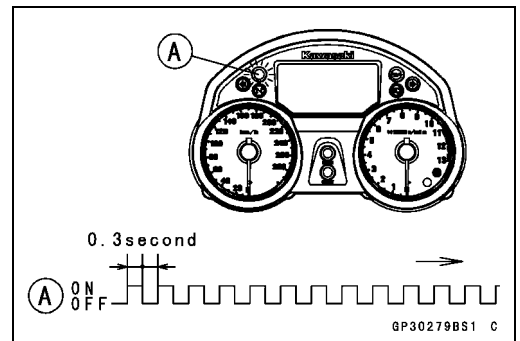

- The user key 2 is registered in the ECU.
- The warning indicator light (LED) [A] blinks 3 times and stops for 1 second and then repeats this cycle.
- This procedure has registered the master key and 2 user keys.
- Continue with the procedure to register an additional 3 user keys.

NOTE

○The ECU can store up the six key codes (master key × 1 and user key × 5).

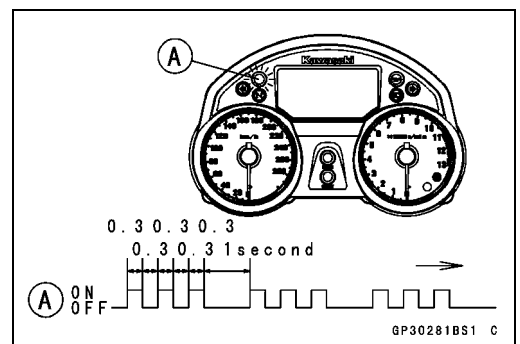

User Key Indicator Light Flashes

	Indicator Light Blinks	Indicator Light Stop	Remarks
User Key 3	4 times	1 seconds	Repeat
User Key 4	5 times	1 seconds	Repeat
User Key 5	6 times	1 seconds	Repeat

- Turn OFF the ignition switch and wait for period of more than 15 seconds.
- The registration mode automatically ends.

16-84 ELECTRICAL SYSTEM

Immobilizer System (Equipped Models)

- Warning indicator light (LED) goes off [A].

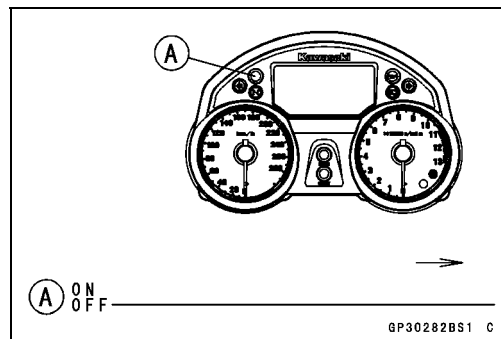

- Remove the key registration unit and connect the immobilizer/Kawasaki diagnostic system connector.

NOTE

- Turn the ignition switch ON with the registered user key.
- Check that the engine can be started using all registered user keys.

Immobilizer System (Equipped Models)

Spare User Key Registration Flow Chart

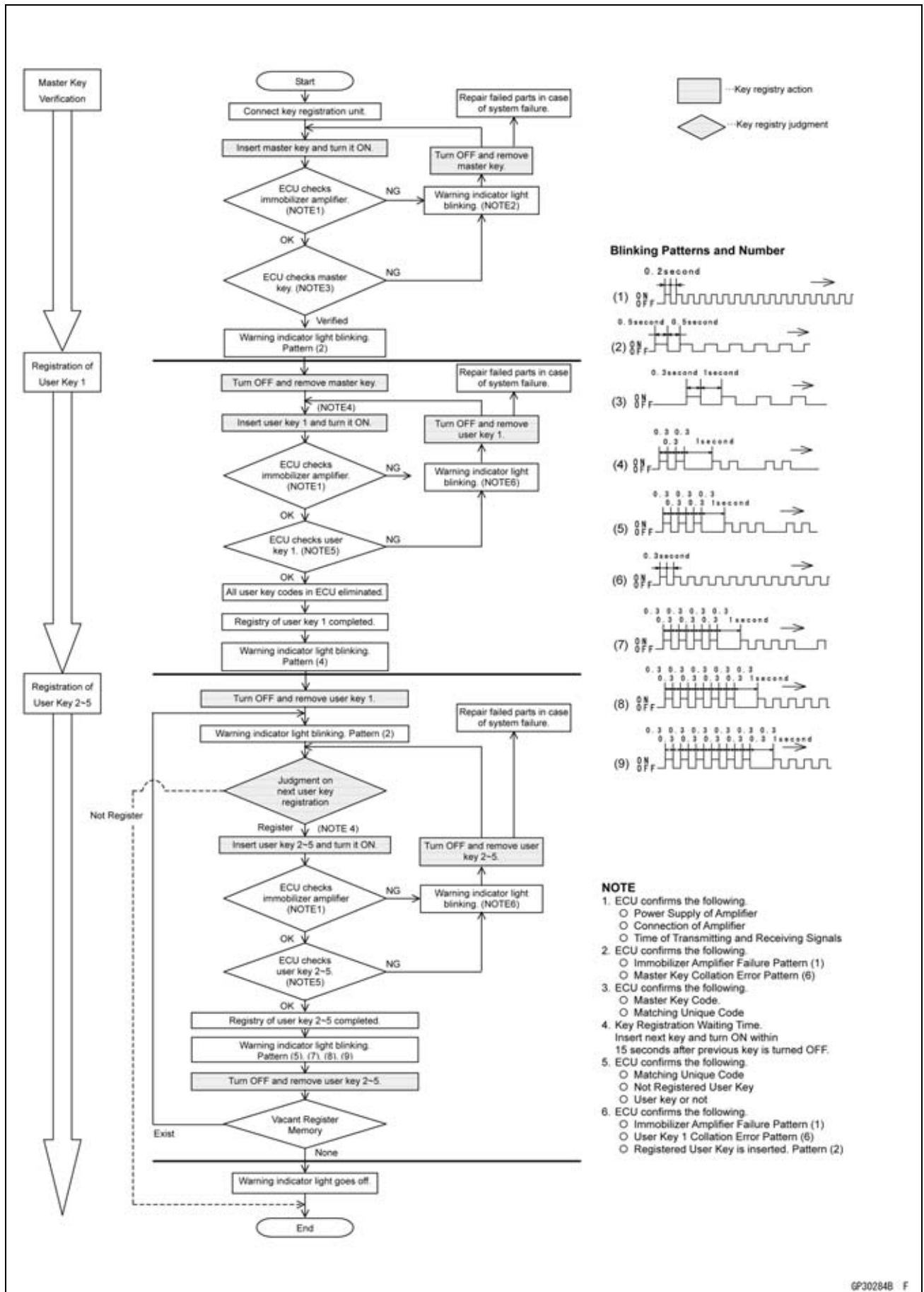

16-86 ELECTRICAL SYSTEM

Immobilizer System (Equipped Models)

Case 2: When the ignition switch is faulty and to be replaced.

- Prepare a new ignition switch [A] and two new user keys [B].
- These parts are available as a set. Prepare the current master key [C].

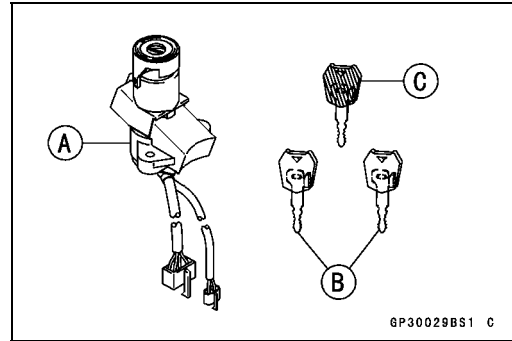

- Remove:
 - Ignition Switch and Immobilizer Antenna (see Immobilizer System Parts Replacement)
 - Seat (see Seat Removal in the Frame chapter)
 - Disconnect the immobilizer/Kawasaki diagnostic system connector.
 - Connect the key registration unit [A].
- Special Tool - Key Registration Unit: 57001-1582**



- Connect:
 - New Ignition Switch Lead Connector [A]
 - Immobilizer Antenna Lead Connector [B]

NOTE

○ Keep the antenna more than 15 cm from the ignition switch.

- Put the current master key [C] at the antenna [D].
- Insert the new user key 1 [E] to the new ignition switch [F] and turn it ON.

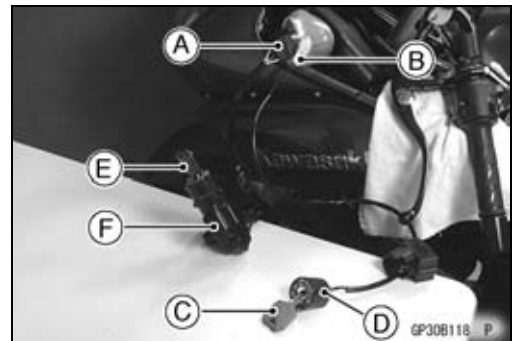

Verified

- The warning indicator light (LED) [A] blinks to display the ECU is in the registration mode (go to the next step).

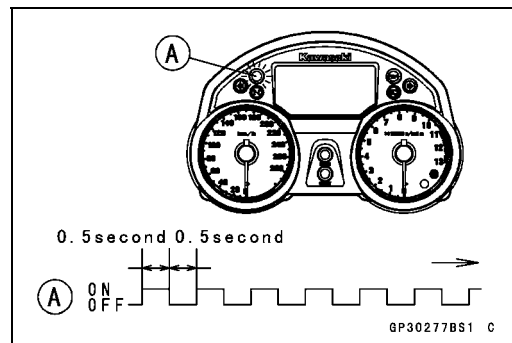

Not Verified

- The warning indicator light (LED) [A] blinks to display the collation error.
 - Immobilizer Amplifier Failure

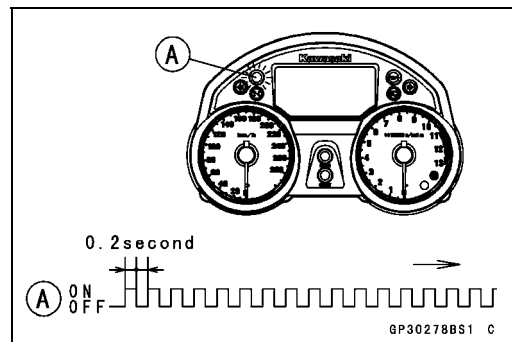

Immobilizer System (Equipped Models)

Master Key Collation Error

- Turn OFF and remove the new user key 1.
- Temporarily place the antenna [A] on the new ignition switch [B].
- Insert the user key 1 [C] again into the new ignition switch and turn it ON.

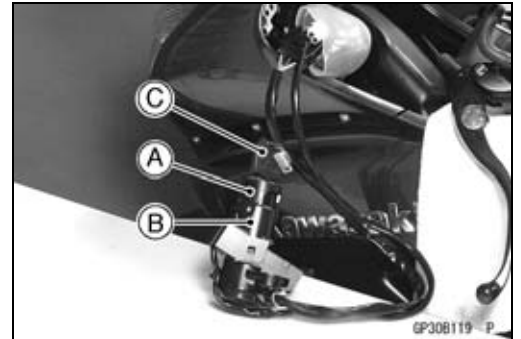
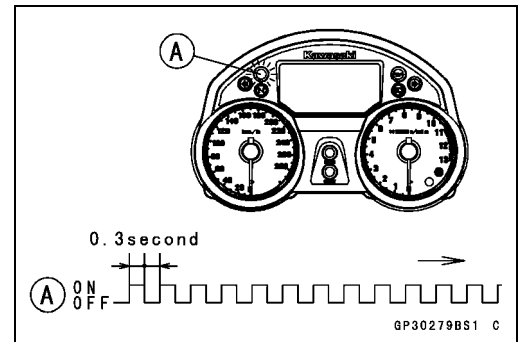

NOTE

- Place the antenna on the ignition switch, insert the next key and turn ON within 15 seconds after previous key is turned off and removed otherwise registration mode will be ended and the warning indicator light (LED) stops flashing.
 - To return to the registration mode start the master key verification procedure. This applies to all user key registration.
 - Keep other user keys away from the immobilizer antenna.
- If there is any problem in the registration, the warning indicator light (LED) [A] blinks to display the collation error.
- Immobilizer Amplifier Failure

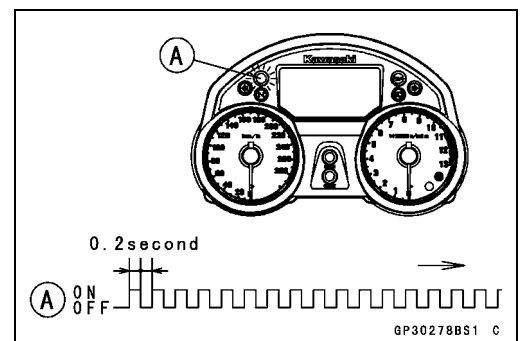

16-88 ELECTRICAL SYSTEM

Immobilizer System (Equipped Models)

When Registered User Key is Inserted.

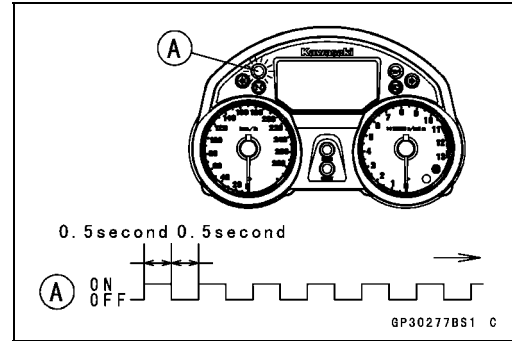

User Key Collation Error

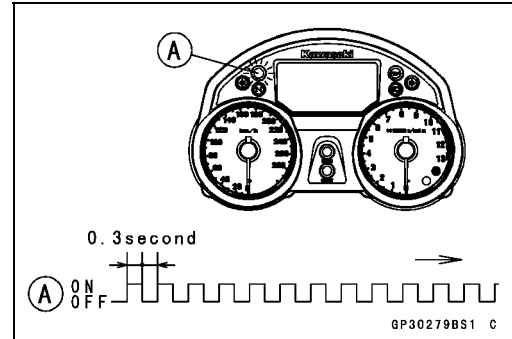

- The user key 1 is successfully registered in the ECU.
- The warning indicator light (LED) [A] blinks 2 times and stops for 1 second and then repeats this cycle to indicate successful registering of user key 1.

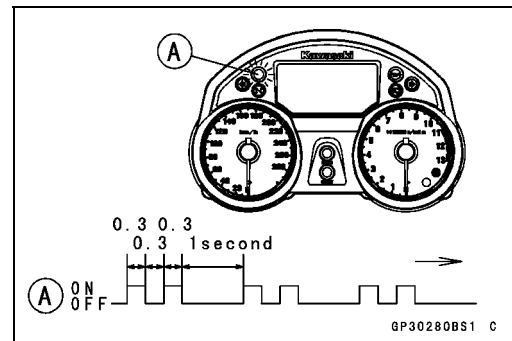

- Turn OFF and remove user key 1.
- The warning indicator light (LED) [A] blinks to display the registration mode.

NOTE

- Turn off the ignition switch and wait for the period more than 15 seconds. The registration mode automatically ends and warning indicator light (LED) goes off.
 - This procedure has , registered the master key and one user key.
 - Continue the procedure to program the second and later keys.
- Insert the user key 2 to the ignition switch and turn it ON.

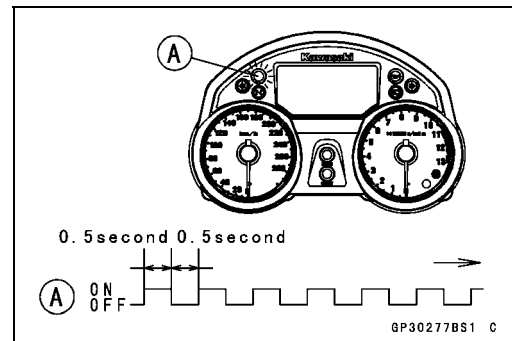

Immobilizer System (Equipped Models)

○If there is any problem in the registration, the warning indicator light (LED) [A] blinks to display the collation error.
Immobilizer Amplifier Failure

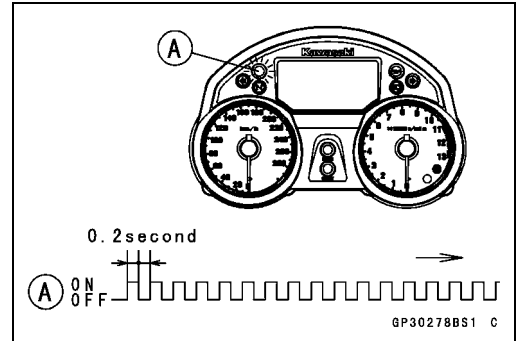

When Registered User Key is Inserted.

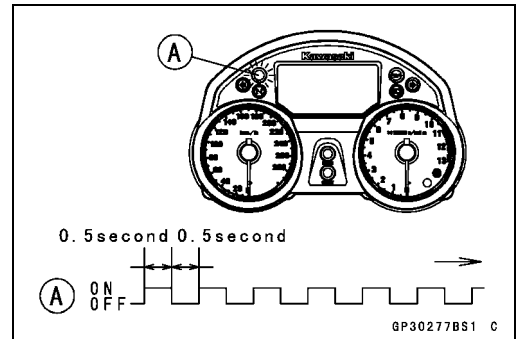

User Key Collation Error

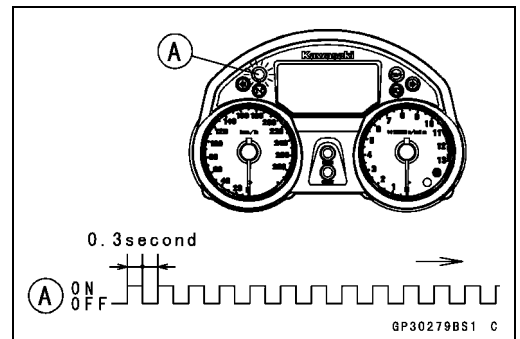

- The user key 2 is successfully registered in the ECU.
- The warning indicator light (LED) [A] blinks 3 times and stops for 1 second and then repeat this cycle to indicate successful programming of user key 2.
- Turn OFF the ignition switch and wait for period more than 15 seconds.
- The registration mode automatically ends.

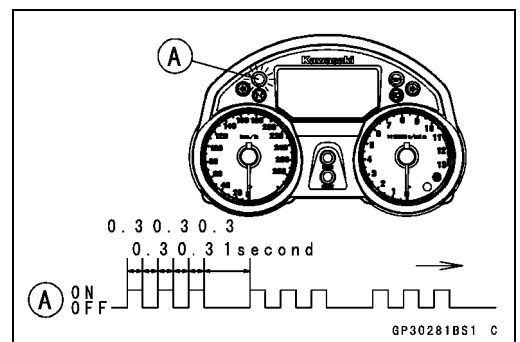

- Warning indicator light (LED) [A] goes off.

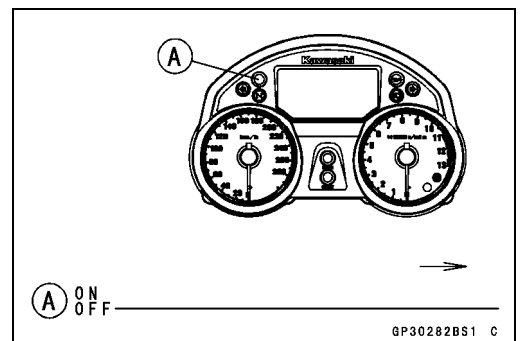

16-90 ELECTRICAL SYSTEM

Immobilizer System (Equipped Models)

- Remove the key registration unit and connect the immobilizer/Kawasaki diagnostic system connector.

NOTE

- Turn the ignition switch ON with the registered user key.
- Check that the engine can be started using all registered user keys.

- Install the new ignition switch and antenna.

Case 3: When the electric control unit (ECU) is faulty and has to be replaced.

- Prepare a new ECU [A], current master key [B] and current user keys [C].

NOTE

- The key registration unit is not required.

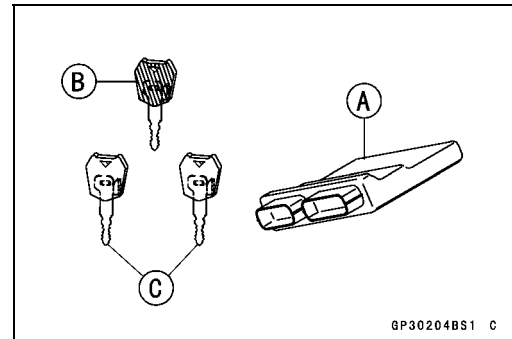

- Replace:
ECU [A] (see Immobilizer System Parts Replacement)

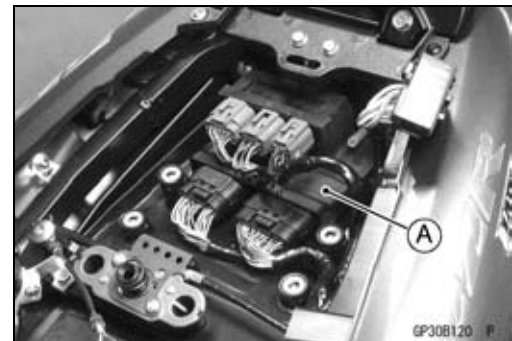

- Insert the current master key into the ignition switch and turn it ON.

- If there is any problem in the registration, the warning indicator light (LED) [A] blinks to display the collation error. Immobilizer Amplifier Failure

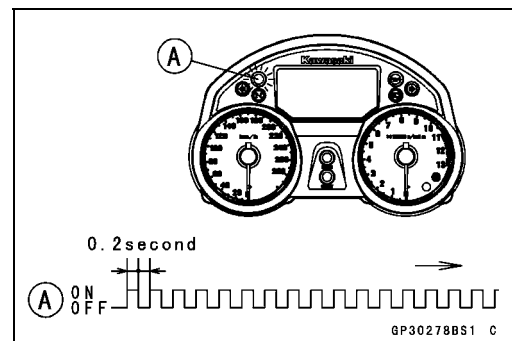

Master Key Collation Error

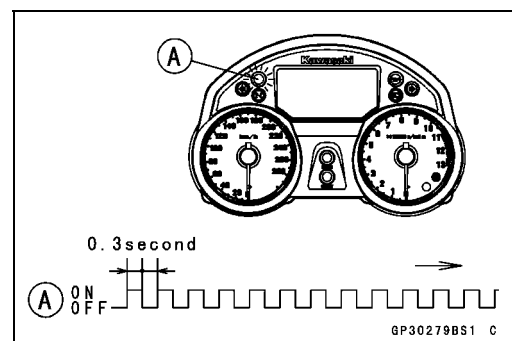

Immobilizer System (Equipped Models)

- The master key is registered in the ECU.
- The warning indicator light (LED) [A] blinks 1 time and stops for 1 second and the repeats this cycle to indicate successful registration of the master key.

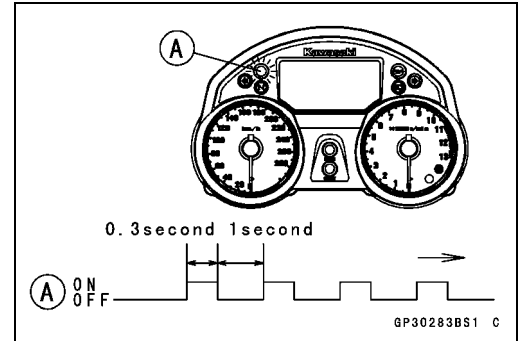

- Turn OFF the master key and remove it.
- The warning indicator light (LED) [A] blinks to display the registration mode.

NOTE

- Insert next key and turn ON within 15 seconds after previous key is turned off and removed otherwise registration mode will be ended and the warning indicator light (LED) goes off.
- To return to the registration mode start the master key verification procedure. This applies to all user key registration.

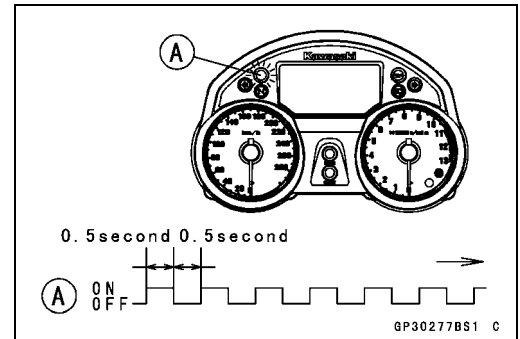

- Insert the user key 1 to the ignition switch and turn it ON.

NOTE

- Keep the other user keys away from the immobilizer antenna.
- If there is any problem in the registration, the warning indicator light (LED) [A] blinks to display the collation error. Immobilizer Amplifier Failure

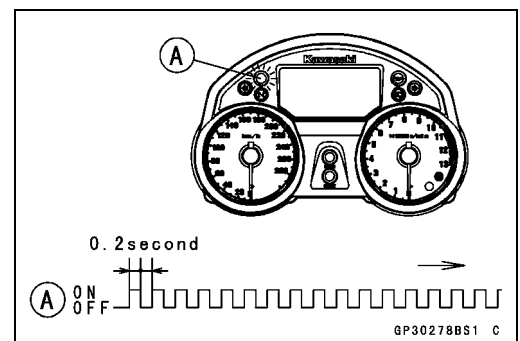

When Registered User Key is Inserted.

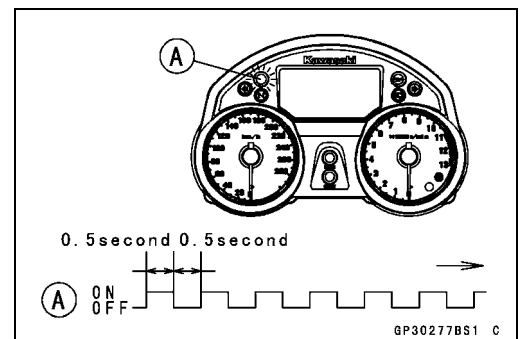

16-92 ELECTRICAL SYSTEM

Immobilizer System (Equipped Models)

User Key Collation Error

- The user key 1 is registered in the ECU.
- The warning indicator light (LED) [A] blinks 2 times and stops for 1 second and then repeats this cycle to indicate successful registration of user key.

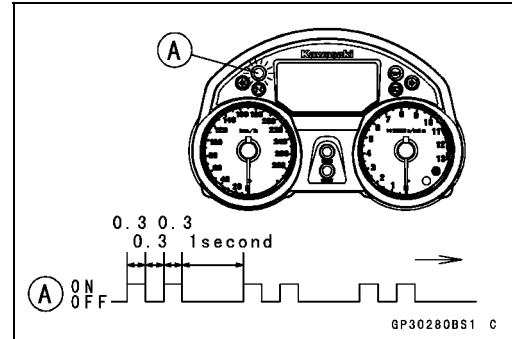
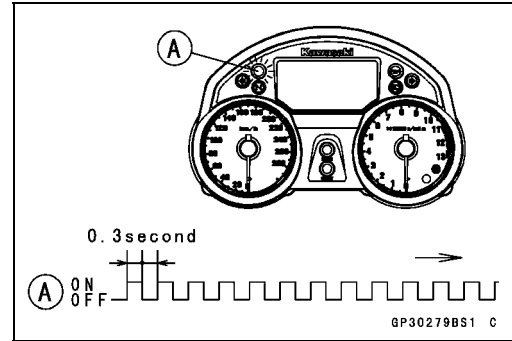

- Turn OFF and remove the user key 1.
- The warning indicator light (LED) [A] blinks to display the registration mode codes.

NOTE

- Insert next key and turn ON within 15 seconds after previous key is turned off and removed otherwise registration mode will be ended and the warning indicator light goes off.
 - To return to the registration mode start the master key verification procedure. This applies to all user key registration.
- Insert the user key 2 to the ignition switch and turn it ON.

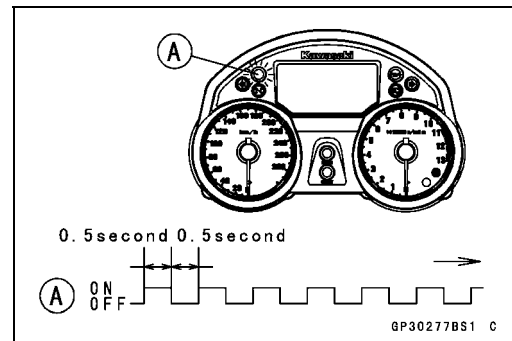

- If there is any problem in the registration, the warning indicator light (LED) [A] blinks to display the collation error code.

Immobilizer Amplifier Failure

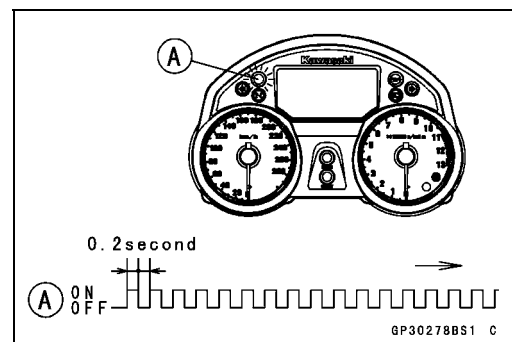

Immobilizer System (Equipped Models)

When Registered User Key is Inserted.

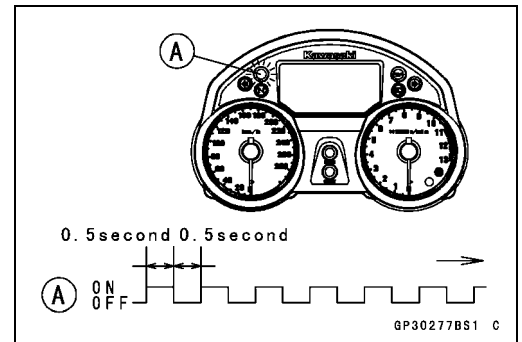

User Key Collation Error

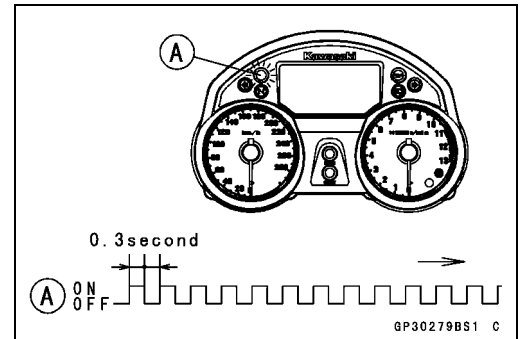

- The user key 2 is registered in the ECU.
- The warning indicator light (LED) [A] blinks 3 times and stops for 1 second and then repeats this cycle to indicate successful registration of user key 2.
- Turn OFF the ignition switch and wait for period more than 15 seconds.
- The registration mode automatically ends.

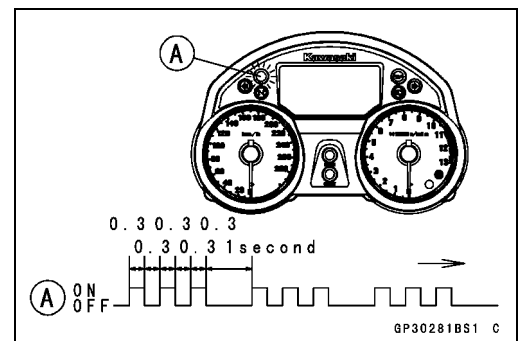

- Warning indicator light (LED) [A] goes off.

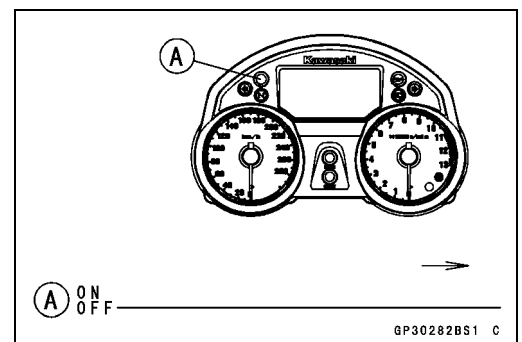

NOTE

- Turn the ignition switch ON with the registered user key.
- Check that the engine can be started using all registered user keys.

Case 4: When master key is faulty or lost.

The master key replacement is considered very rare case. However if it is required, the following is necessary.

NOTE

- The ECU must be replaced with a new one because the master key code that is registered in the current ECU can not be rewritten.

16-94 ELECTRICAL SYSTEM

Immobilizer System (Equipped Models)

- Prepare a new ECU [A], new master key [B] and current user keys [C].

NOTE

- *The key registration unit is not required.*
- *The key registration process is same as the electric control unit replacement.*

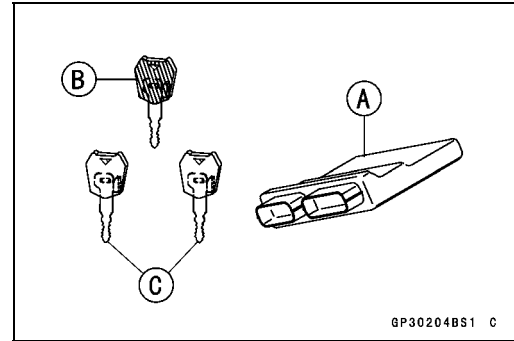

Case 5: When replacing the antenna.

- Prepare a new antenna.
- Refer to the Immobilizer System Parts Replacement.

NOTE

- *No key registration is required.*

16-96 ELECTRICAL SYSTEM

Immobilizer System (Equipped Models)

Immobilizer System Parts Replacement

Immobilizer Antenna

- Remove the left inner cover (see Inner Cover Removal in the Frame chapter).
- Disconnect the lead connectors [A].

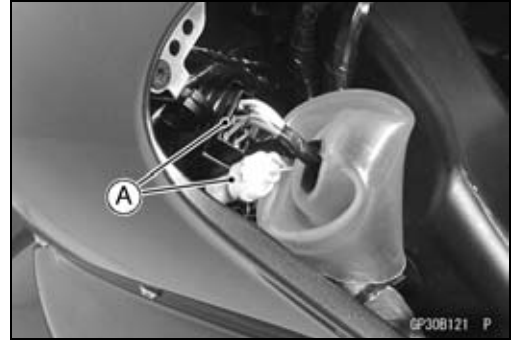

- Remove:
 - Steering Stem Head (see Stem, Stem Bearing Removal in the Steering chapter)
- Using a small chisel or punch [A], turn out the Torx bolts.

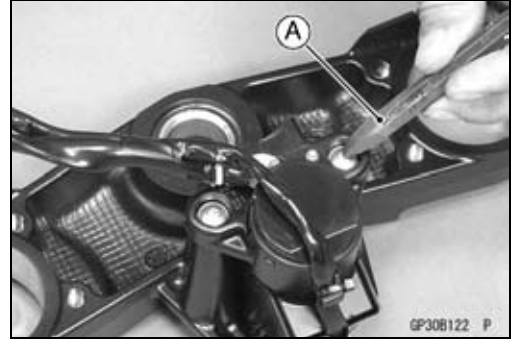

- Cut the band [A].
- Remove the screw [B].
- Remove the antenna [C] with the cover [D].
- Pull the lower parts [E] of the cover outside to clear the projection [F] of the ignition switch.

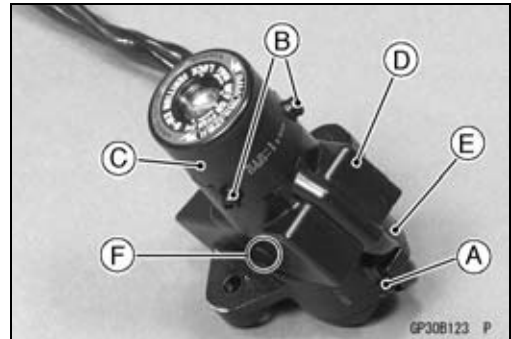

- Tighten a new Torx bolt [A] until the bolt head [B] is broken.
- [C] Broken Head of Other Side
- Run the leads correctly (see Cable, Wire, and Hose Routing section in the Appendix chapter).



Immobilizer Amplifier Replacement

- Remove the windshield (see Windshield Removal in the Frame chapter).
- Disconnect the connector [A].
- Remove the amplifier [B] from the bracket [C].

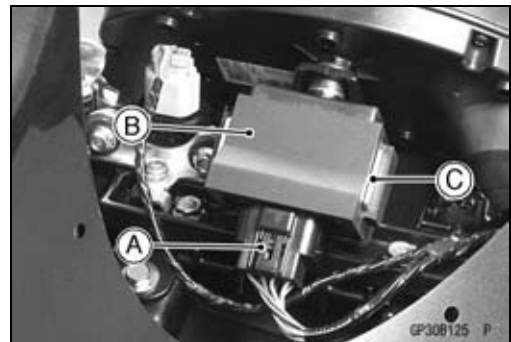

Immobilizer System (Equipped Models)

ECU (Electric Control Unit) Replacement (for Immobilizer Models)

- Remove:
 - Seat (see Seat Removal in the Frame chapter)
 - Tool Kit [A]
 - Fuse Box [B]

- Using small chisel or other suitable tool, cut off the screws [A].
- Remove:
 - Plate [B]
 - Tool Kit Case [C]

- Remove:
 - Relay Box [A]
 - ECU Connectors [B]
 - ECU [C]

- Install:
 - ECU Connectors
 - Relay Box
- Insert the slits of the rubber protector to the projections [A] of the rear fender front.

- Install:
 - Connector Holder [A]

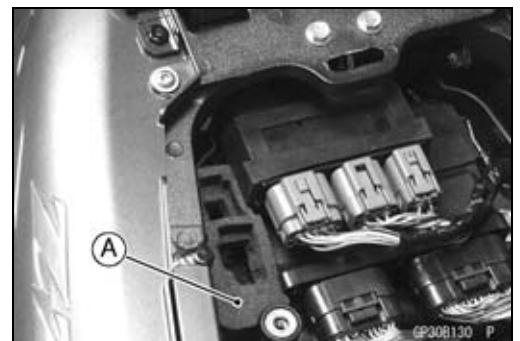
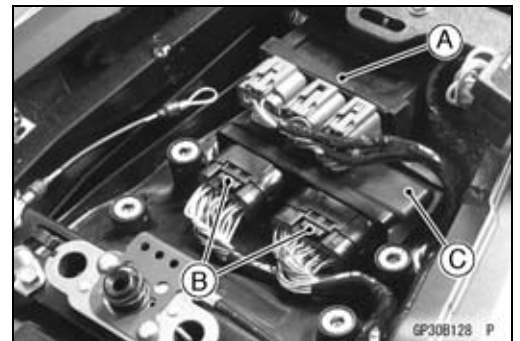
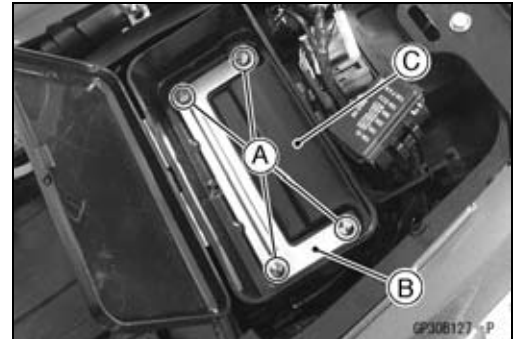
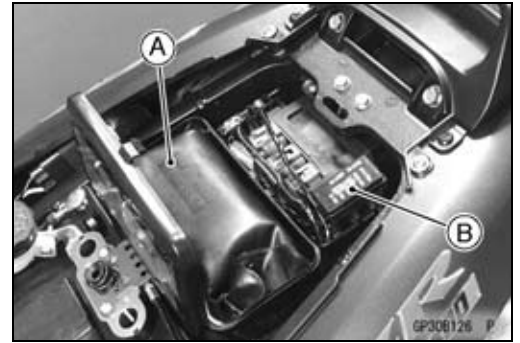

16-98 ELECTRICAL SYSTEM

Immobilizer System (Equipped Models)

- Install:
 - Tool Kit Case [A]
 - Plate [B]
- Tighten the new Kawasaki genuine screws [C] of which threads are coated with locking agent.
- Insert the stopper [D] of the fuse box into the groove [E] of the tool kit case.

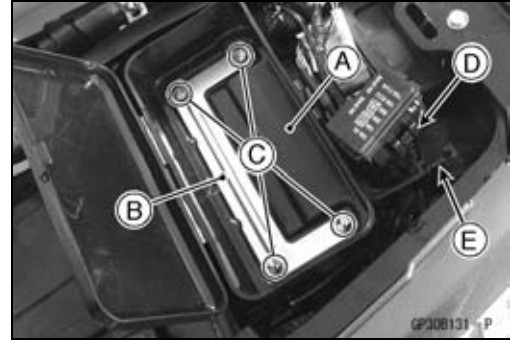

Immobilizer Relational Parts Replacement Chart

		Failed or Lost Part					
		Master Key (Red)	User Key (Black)	Ignition Switch	Antenna	Amplifier	ECU
*	Master Key (Red)	●					
	User Key (Black)		●	○			
	Ignition Switch			●			
	Antenna				●		
	Amplifier					●	
	ECU	○					●
*	Replacement Part						
●	Main Replacement Part						
○	Additional Replacement Part						

Immobilizer System Inspection

- Refer to the Immobilizer Amplifier and Blank Key Detection section in Fuel System (DFI) chapter (see Immobilizer Amplifier (Service Code 35) section in the Fuel System (DFI) chapter).

Immobilizer System (Equipped Models)

Immobilizer System Circuit

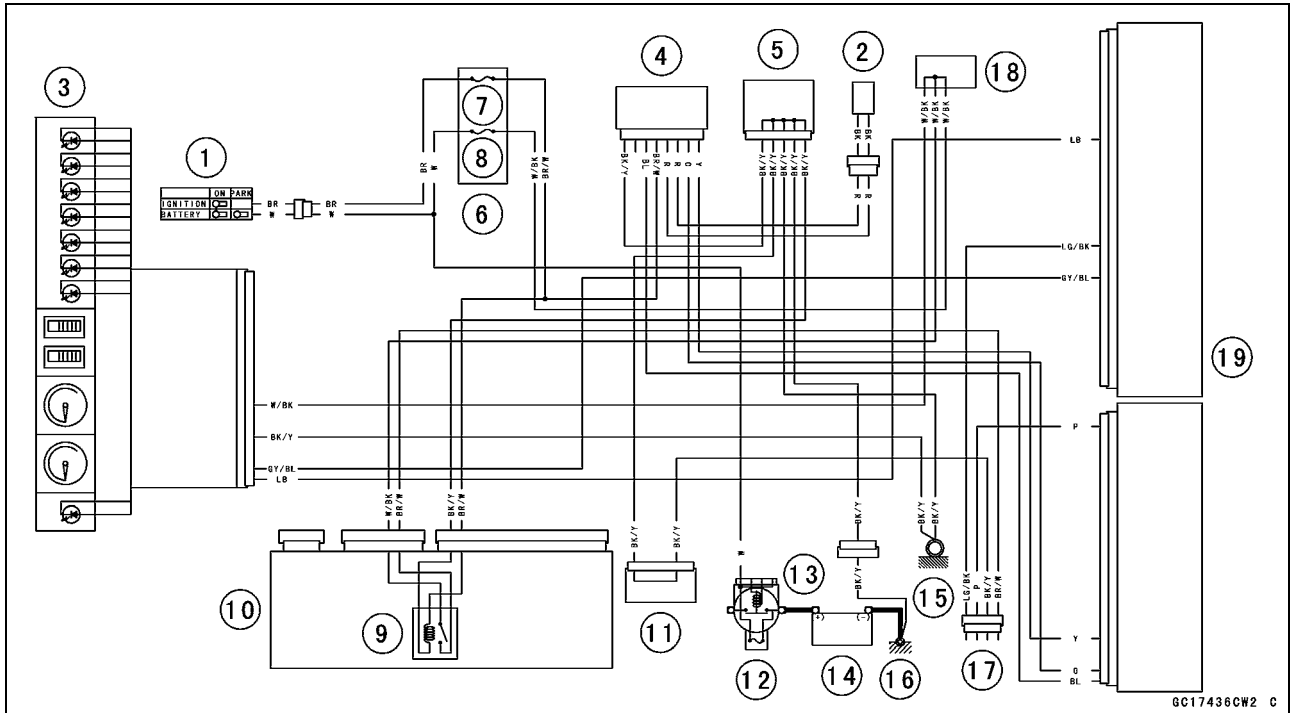

1. Ignition Switch
2. Immobilizer Antenna
3. Meter Unit
4. Immobilizer Amplifier
5. Joint Connector 1
6. Fuse Box 2
7. ECU Fuse 15 A
8. Ignition Fuse 10 A
9. Main Relay
10. Relay Box
11. Joint Connector 2
12. Main Fuse 30 A
13. Starter Relay
14. Battery 12 V 14 Ah
15. Frame Ground 1
16. Frame Ground 2
17. Immobilizer/Kawasaki Diagnostic System Connector
18. Water-proof Joint 1
19. ECU

16-100 ELECTRICAL SYSTEM

Switches and Sensors

Brake Light Timing Inspection

- Refer to the Brake Light Switch Operation Inspection in the Periodic Maintenance chapter.

Brake Light Timing Adjustment

- Refer to the Brake Light Switch Operation Inspection in the Periodic Maintenance chapter.

Switch Inspection

- Using a hand tester, check to see that only the connections shown in the table have continuity (about zero ohms).
- For the switch housings and the ignition switch, refer to the tables in the Wiring Diagram.
- ★ If the switch has an open or short, repair it or replace it with a new one.

Special Tool - Hand Tester: 57001-1394

Rear Brake Light Switch Connections

Rear Brake Light Switch Connections		
Color	BR	BL
When brake pedal is pushed down	○ — ○	○ — ○
When brake pedal is released		

Sidestand Switch Connections

Sidestand Switch Connections		
Color	BK	G
When sidestand is down		
When sidestand is up	○ — ○	○ — ○

Oil Pressure Switch Connections*

Oil Pressure Switch Connections *		
Color	SW. Terminal	Ground
When engine is stopped	○ — ○	○ — ○
When engine is running		

*: Engine lubrication system is in good condition.

Switches and Sensors

Water Temperature Sensor Inspection

- Remove the water temperature sensor (see Removal/Installation in the Fuel System (DFI) chapter).
- Suspend the sensor [A] in a container of coolant so that the threaded portion is submerged.
- Suspend an accurate thermometer [B] with temperature sensing portions [C] located in almost the same depth.

NOTE

- The sensor and thermometer must not touch the container side or bottom.
- Place the container over a source of heat and gradually raise the temperature of the coolant while stirring the coolant gently.
- Using the hand tester, measure the internal resistance of the sensor.
- The sensor sends electric signals to the ECU and coolant temperature gauge in the meter unit.
- Measure the resistance across the terminals and the body (for the gauge) at the temperatures shown in the table.
- ★ If the hand tester does not show the specified values, replace the sensor.

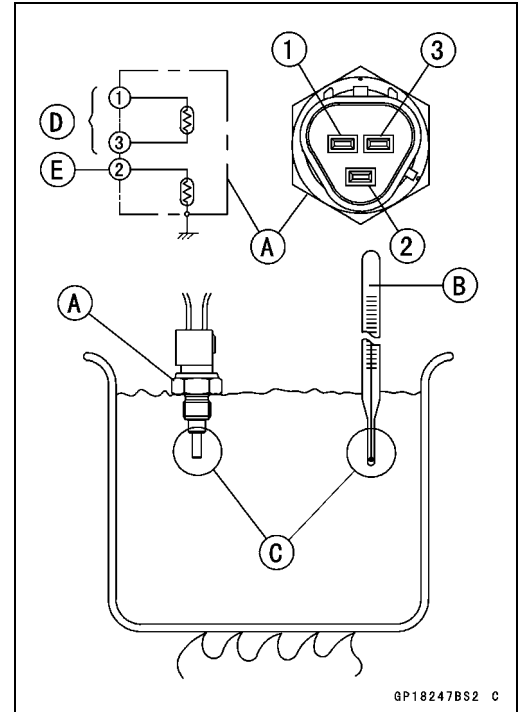

Water Temperature Sensor

Resistance for ECU [D]	
Temperature	Resistance (kΩ) (Terminal [1]-[3])
20°C (68°F)	2.46 +0.115 -0.143
80°C (176°F)	0.32 ±0.011
110°C (230°F)	0.1426 ±0.0041

Resistance for Water Temperature Gauge [E]	
Temperature	Resistance (Ω) (Terminal [2]-Body)
50°C (122°F)	210 ±40
120°C (248°F)	21.2 ±1.5

Speed Sensor Removal

- Loosen the bolt [A].
- Disconnect the speed sensor lead connector [B].
- Remove:
 - Bolt [C]
 - Speed Sensor [D]

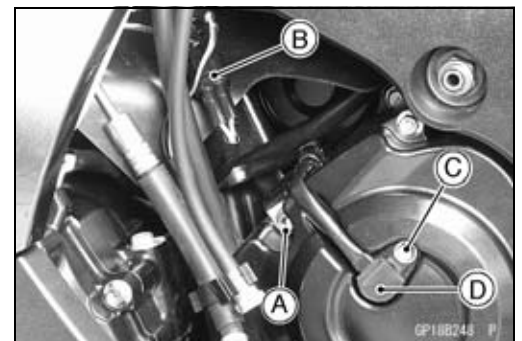

Speed Sensor Installation

- Apply a non-permanent locking agent to the sensor bolt.
- Install the speed sensor.

Torque - Speed Sensor Bolt: 3.9 N·m (0.40 kgf·m, 35 in·lb)

16-102 ELECTRICAL SYSTEM

Switches and Sensors

Speed Sensor Inspection

- Remove the speed sensor (see Speed Sensor Removal).
- Connect the speed sensor lead connector [A] with the battery [B], 10 k Ω resistor [C] and hand tester [D] as shown.
- Set the tester to the DC 25 V range.

Special Tool - Hand Tester: 57001-1394

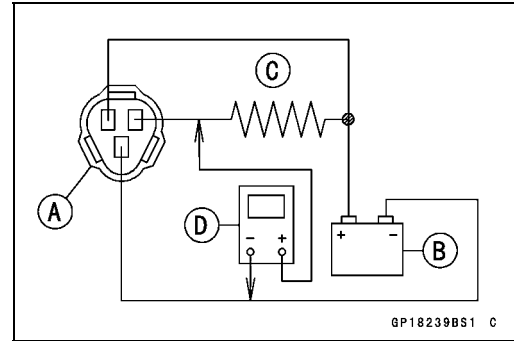

- Trace [A] each side of the speed sensor surface with the screw driver.
- Then the tester indicator should flick [B].
- ★ If the tester indicator does not flick, replace the speed sensor.

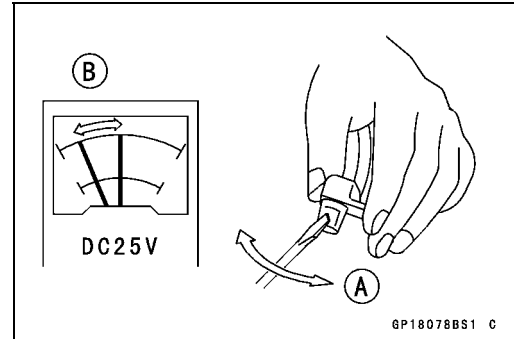

Fuel Level Sensor Inspection

- Remove the fuel tank (see Fuel Tank Removal in the Fuel System (DFI) chapter).
- Open the clamps [A].
- Remove:
 - Bolts [B]
 - Fuel Level Sensor [C]

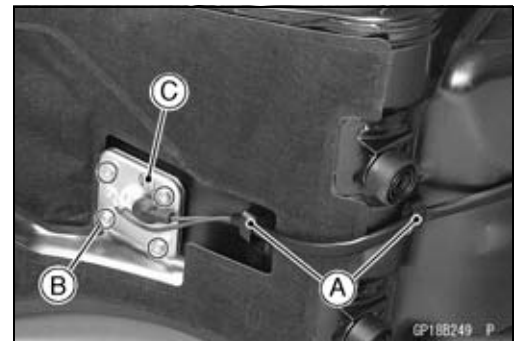

- Check that the float moves up and down smoothly without binding. It should go down under its own weight.
- ★ If the float does not move smoothly, replace the sensor.
 - Float in Full Position [A]
 - Float in Empty Position [B]
 - Float Arm Stoppers [C]

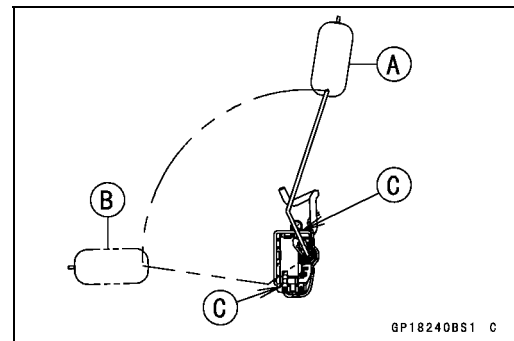

- Using the hand tester [A], measure the resistance across the terminals in the fuel level sensor lead connector [B].

Special Tools - Hand Tester: 57001-1394

Needle Adapter Set: 57001-1457

- ★ If the tester readings are not as specified, or do not change smoothly according as the float moves up and down, replace the sensor.

Fuel Level Sensor Resistance

Standard: Full position [C]: 9 ~ 11 Ω

Empty position: 213 ~ 219 Ω

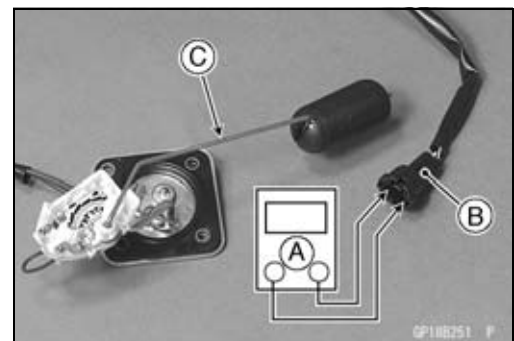

Switches and Sensors

- Install a new gasket [A] on the fuel level sensor as shown.
Hollows [B]
Front [C]
- Apply a non-permanent locking agent to the threads of the level sensor bolts and tighten it.

Torque - Fuel Level Sensor Bolts: 6.9 N·m (0.70 kgf·m, 61 in·lb)

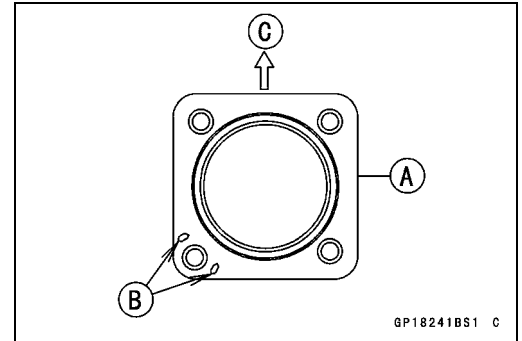

Fuel Reserve Switch Inspection

- Fill the fuel tank with fuel.
- Close the fuel tank cap surely.
- Remove the fuel tank (see Fuel Tank Removal in the Fuel System (DFI) chapter).
- Connect the test light [A] (12 V 3.4 W bulb in a socket with leads) and the 12 V battery [B] to the fuel pump connector [C].

Connections

Battery (+) → 12 V 3.4 W Bulb (one side)

12 V 3.4 W Bulb (other side) → BK/R Lead Terminal

Battery (-) → BK/W Lead Terminal

Special Tool - Needle Adapter Set: 57001-1457

- ★ If the test light turn on, the reserve switch is defective. Replace the fuel pump.

- Remove the fuel pump (see Fuel Pump Removal in the Fuel System (DFI) chapter).
- Connect the test light (12 V 3.4 W bulb in a socket with leads) and the 12 V battery to the fuel pump connector as shown.

12 V Battery [A]

Test Light [B]

Fuel Pump Connector [C]

Fuel Reserve Switch [D]

- ★ If the test light doesn't light, replace the fuel pump.

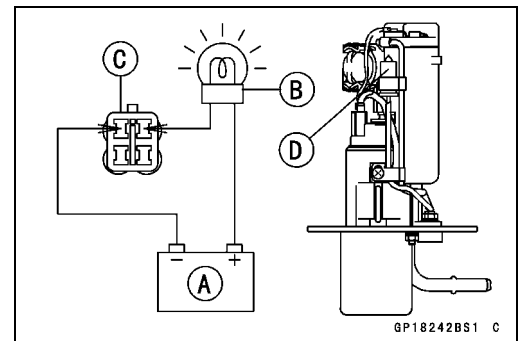
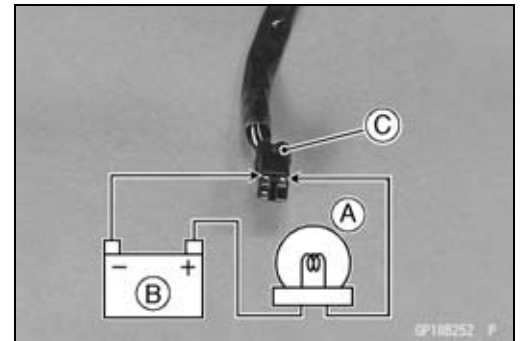

NOTE

- It may take a long time to turn on the test light in case that the fuel reserve switch is inspected just after the fuel pump is removed. Leave the fuel reserve switch with leads for inspection connected for few minutes.

16-104 ELECTRICAL SYSTEM

Switches and Sensors

Gear Position Switch Removal

- Remove the lower fairings (see Lower Fairing Removal in the Frame chapter).
- Slide out the rubber boot [A].
- Loosen the oil pressure switch terminal bolt [B], and remove the switch lead [C].

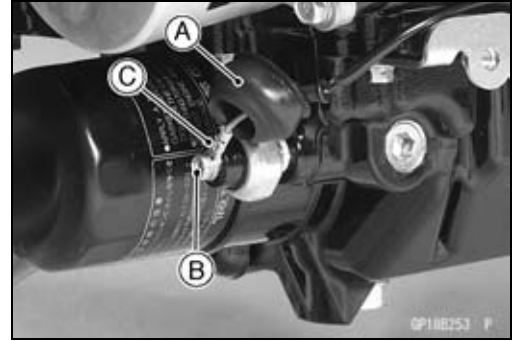

- Open the clamps [A].

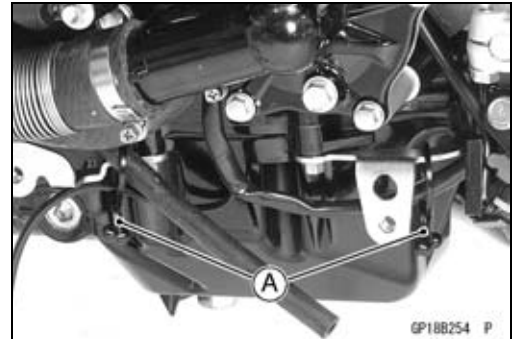

- Remove:
 - Engine Sprocket Cover (see Engine Sprocket Removal in the Final Drive chapter)
 - Bolt [A]
 - Clamp [B]
- Disconnect the oil pressure switch/gear position switch lead connector [C].

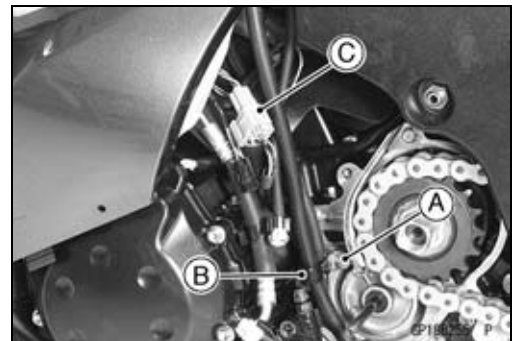

- Open the clamp [A].
- Remove:
 - Screws [B]
 - Gear Position Switch [C]

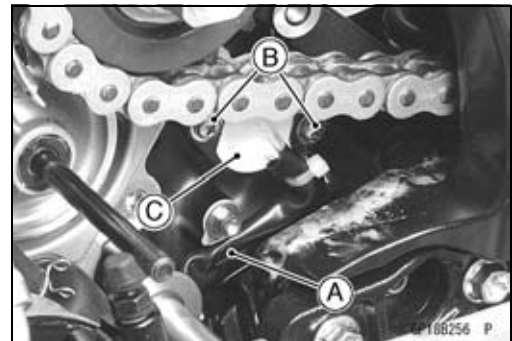

- Remove the pin [A] and spring from the shift drum.



Switches and Sensors

Gear Position Switch Installation

- Securely place the spring [A] and pin [B] into the hole [C] of the shift drum.
- Apply grease to the new O-ring [D].
- Apply a non-permanent locking agent to the gear position switch screws.
- Tighten:
 - Torque - Gear Position Switch Screws: 3.0 N·m (0.31 kgf·m, 27 in·lb)**
 - Gear Position Switch Lead Clamp Bolt: 9.8 N·m (1.0 kgf·m, 87 in·lb)**
- Run the gear position switch and oil pressure switch lead correctly (see Cable, Wire, and Hose Routing section in the Appendix chapter).
- Install the removed parts (see appropriate chapters).

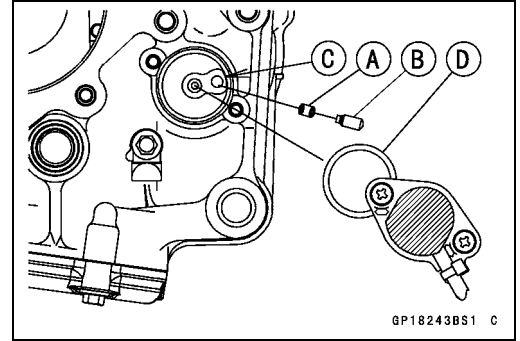

Gear Position Switch Inspection

NOTE

○ Be sure the transmission mechanism is good condition.

- Disconnect the connector [A].

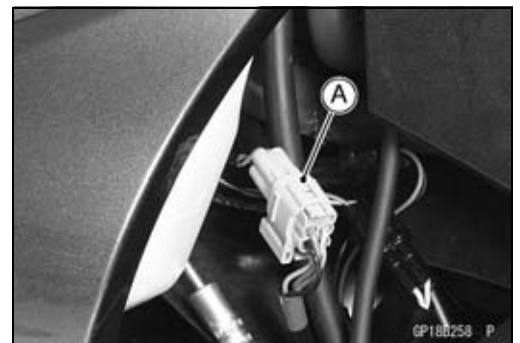

- Set the hand tester [A] to the 1 kΩ or × 100 Ω range and connect it to the terminals in the oil pressure switch/gear position switch lead connector [B] and ground.
 - [C] Internal Circuit
 - [1] Light Green Lead
 - [2] Green/Red Lead
 - [3] Black Lead

Special Tool - Hand Tester: 57001-1394

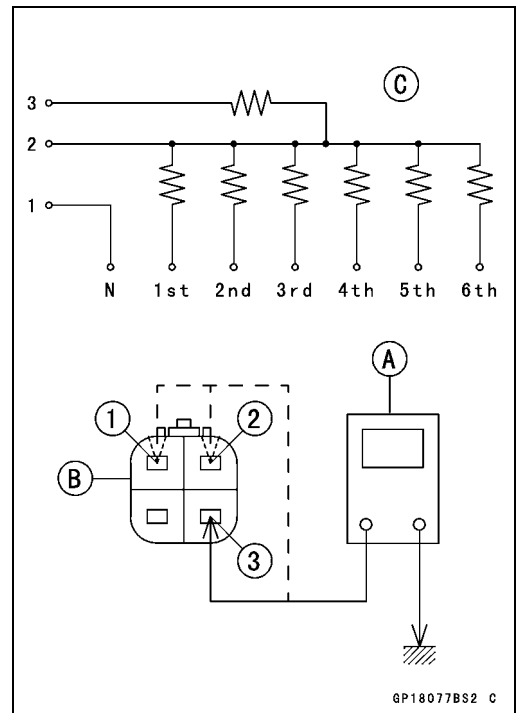

Gear Position Switch Resistance

kΩ

Gear Position	Connections		
	[1]-Ground	[2]-Ground	[3]-Ground
Neutral	about 0	—	—
1st	—	3.00 ~ 3.32	11.63 ~ 12.87
2nd	—	1.70 ~ 1.89	10.33 ~ 11.44
3rd	—	1.07 ~ 1.19	9.70 ~ 10.74
4th	—	0.695 ~ 0.769	9.32 ~ 10.32
5th	—	0.430 ~ 0.476	9.06 ~ 10.03
6th	—	0.248 ~ 0.274	8.89 ~ 9.81

★ If the tester reading is not as specified, replace the gear position switch with a new one.

16-106 ELECTRICAL SYSTEM

Relay Box

The relay box [A] has relays and diodes. The relays and diodes can not be removed.



Relay Box Removal

- Remove the seat (see Seat Removal in the Frame chapter).
- Take out the relay box [A] and disconnect the connectors [B].

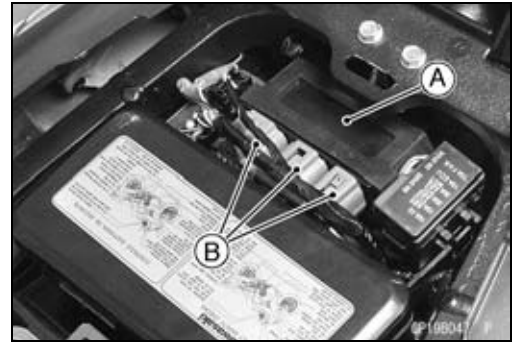

Relay Circuit Inspection

NOTE

○The ECU main relay function is included in the ECU.

- Remove the relay box (see Relay Box Removal).
- Check conductivity of the following numbered terminals by connecting the hand tester and one 12 V battery to the relay box as shown (see Relay Box Internal Circuit).
- ★ If the tester does not read as specified, replace the relay box.

Relay Circuit Inspection (with the battery disconnected)

	Tester Connection	Tester Reading (Ω)
Headlight Circuit Relay	1-3	∞
Main Relay	6-7	∞
	4-5	Not ∞^*
Fuel Pump Relay	7-8	∞
	9-10	Not ∞^*
Starter Circuit Relay	11-16	∞
	11-12	∞
Fan Relay	17-20	∞
	18-19	Not ∞^*

*: The actual reading varies with the hand tester used.

Relay Box

Relay Circuit Inspection (with the battery connected)

	Battery Connection (+) (-)	Tester Connection	Tester Reading (Ω)
Main Relay	2-11	1-3	0
	4-5	7-6	0
Fuel Pump Relay	9-10	7-8	0
Fan Relay	18-19	17-20	0

	Battery Connection (+) (-)	Tester Connection DC 25 V Range	Tester Reading (V)
Starter Circuit Relay	16-12	11-12	Battery Voltage

(+): Apply positive lead.

(-): Apply negative lead.

Diode Circuit Inspection

- Remove the relay box (see Relay Box Removal).
- Check conductivity of the following pairs of terminals (see Relay Box Internal Circuit).

Diode Circuit Inspection

Tester Connection	1-11, 2-11, 12-13, 12-15, 12-16, 13-14, 13-15
-------------------	---

- ★ The resistance should be low in one direction and more than ten times as much in the other direction. If any diode shows low or high in both directions, the diode is defective and the relay box must be replaced.

NOTE

- *The actual meter reading varies with the meter or tester used and the individual diodes, but generally speaking, the lower reading should be from zero to one half the scale.*

16-108 ELECTRICAL SYSTEM

Relay Box

Relay Box Internal Circuit

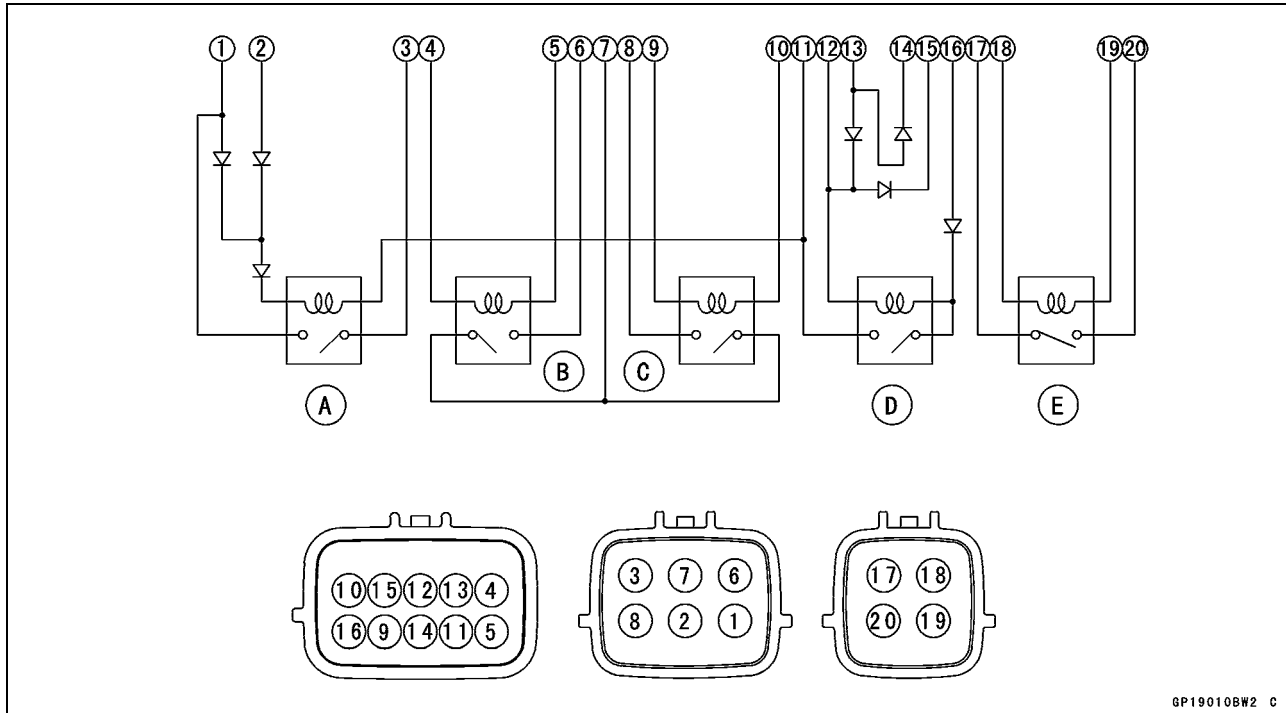

GP190108W2 C

- A. Headlight Circuit Relay
- B. Main Relay
- C. Fuel Pump Relay
- D. Starter Circuit Relay
- E. Fan Relay

Fuse

30 A Main Fuse Removal

- Remove:
 - Fuel Tank (see Fuel Tank Removal in the Fuel System (DFI) chapter)
 - Bolts [A]
 - Cover [B]

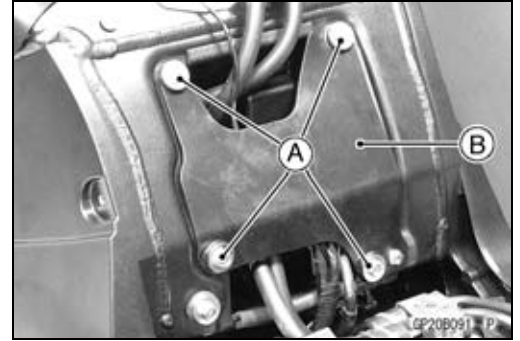

- Disconnect the 30 A main fuse connector [A].



- Pull out the main fuse [A] from the starter relay with needle nose pliers.



Fuse Box Fuse Removal

- Remove the seat (see Seat Removal in the Frame chapter).
- Unlock the hook [A] to lift up the lid [B].

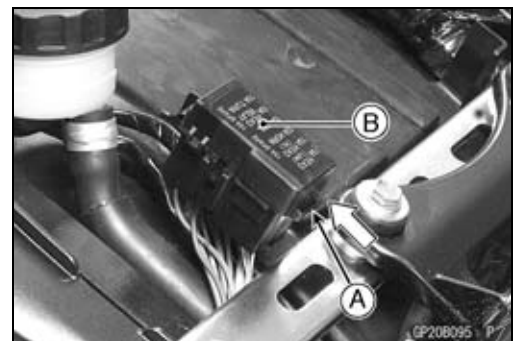
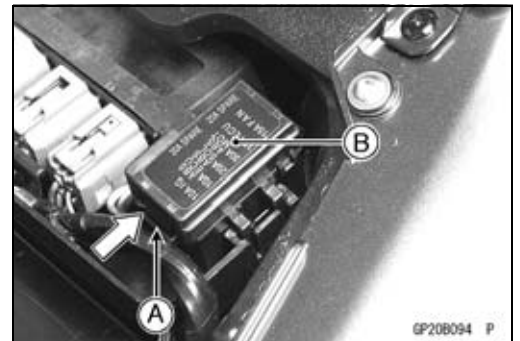

16-110 ELECTRICAL SYSTEM

Fuse

- Pull the fuses [A] straight out of the fuse box with needle nose pliers.

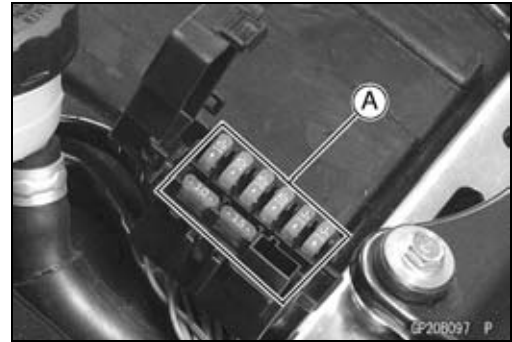

15 A ECU Fuse Removal

- Remove the seat (see Seat Removal in the Frame chapter).
- Unlock the hook [A] to lift up the lid [B].

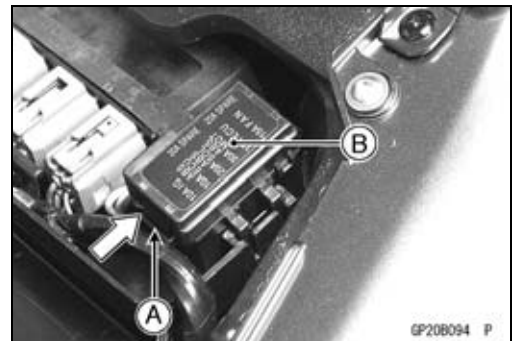

- Pull out the ECU fuse [A] from the fuse box.

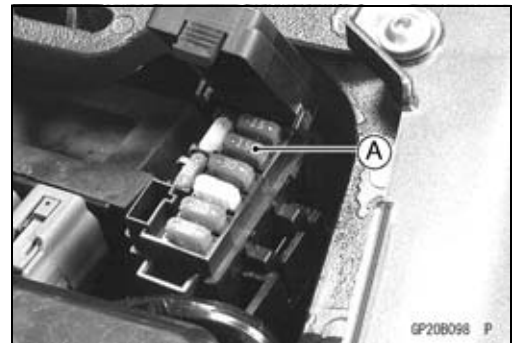

Fuse Installation

- ★ If a fuse fails during operation, inspect the electrical system to determine the cause, and then replace it with a new fuse of proper amperage.
- Install the fuse box fuses on the original position as specified on the lid.

Fuse

Fuse Inspection

- Remove the fuse (see 30 A Main/Fuse Box/15 A ECU Fuse Removal).
- Inspect the fuse element.
- ★ If it is blown out, replace the fuse. Before replacing a blown fuse, always check the amperage in the affected circuit. If the amperage is equal to or greater than the fuse rating, check the wiring and related components for a short circuit.

Housing [A]

Fuse Element [B]

Terminals [C]

Blown Element [D]

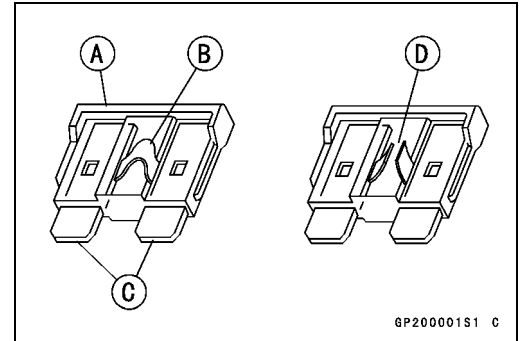

NOTE

- A mass current flows to the battery according to the state of the battery which needs refreshing charge when the engine is turned causing main fuse blown out.

CAUTION

When replacing a fuse, be sure the new fuse matches the specified fuse rating for that circuit. Installation of a fuse with a higher rating may cause damage to wiring and components.

Appendix

Table of Contents

Cable, Wire, and Hose Routing 17-2
Troubleshooting Guide 17-52

17-2 APPENDIX

Cable, Wire, and Hose Routing

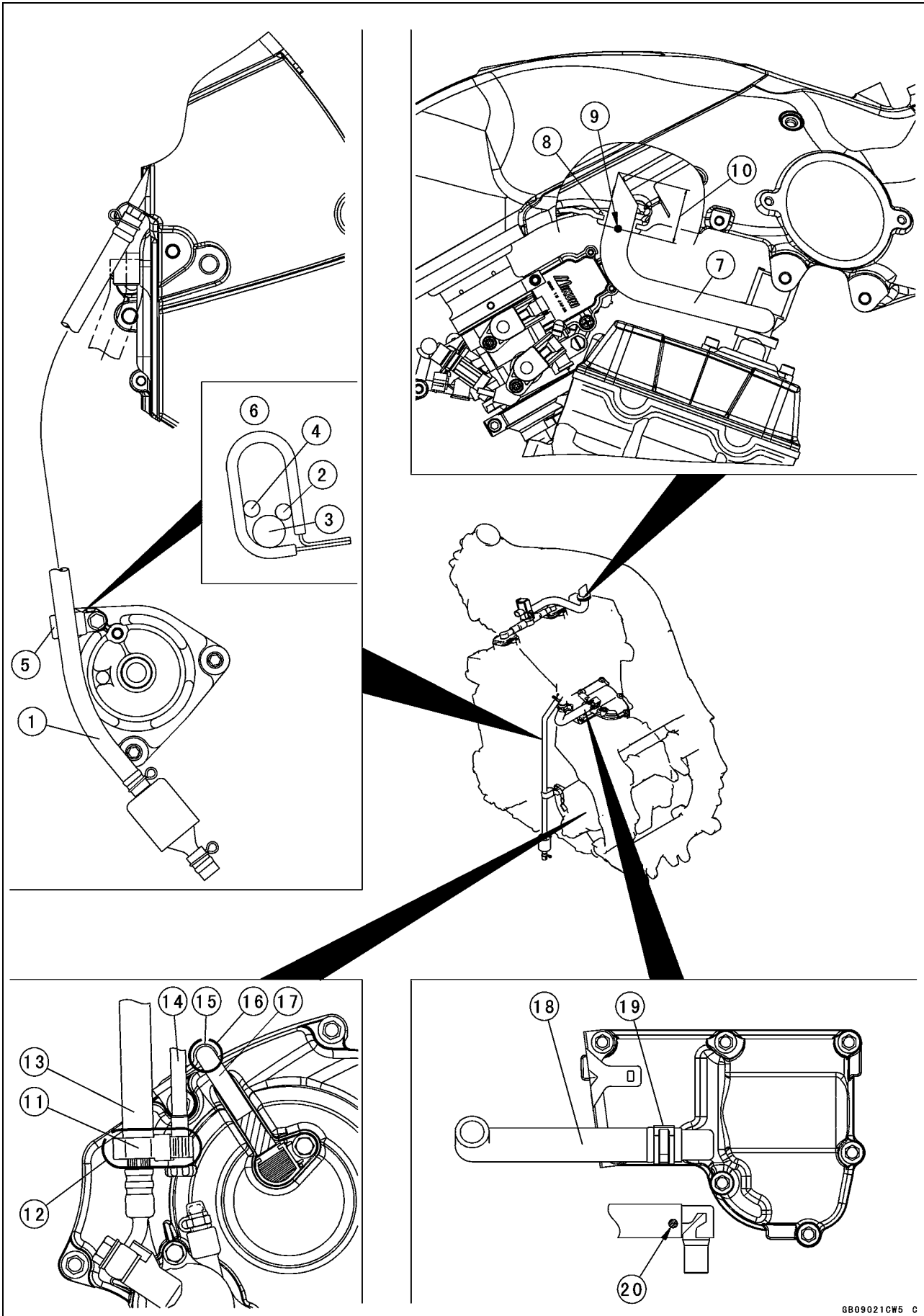

Cable, Wire, and Hose Routing

1. Air Cleaner Drain Hose
2. Gear Position Switch Lead
3. Air Bleeder Hose for Water Pump
4. Sidestand Switch Lead
5. Clamp
6. Clamp the leads and hose as shown in the figure.
7. Tube
8. Grommet
9. Install the air switching valve hose until white paint is half hidden level.
10. Approx. 41 mm (0.02 in.)
11. Clamp
12. First, put the clamp to the adjuster screw position of shown in the figure, next fix to the clutch hose.
13. Clutch Hose
14. Idle Adjusting Screw
15. Clamp
16. Clamp the speed sensor lead.
17. Speed Sensor Lead
18. Breather Tube
19. Clamp
20. Align the white paint and the end of the plate.

17-4 APPENDIX

Cable, Wire, and Hose Routing

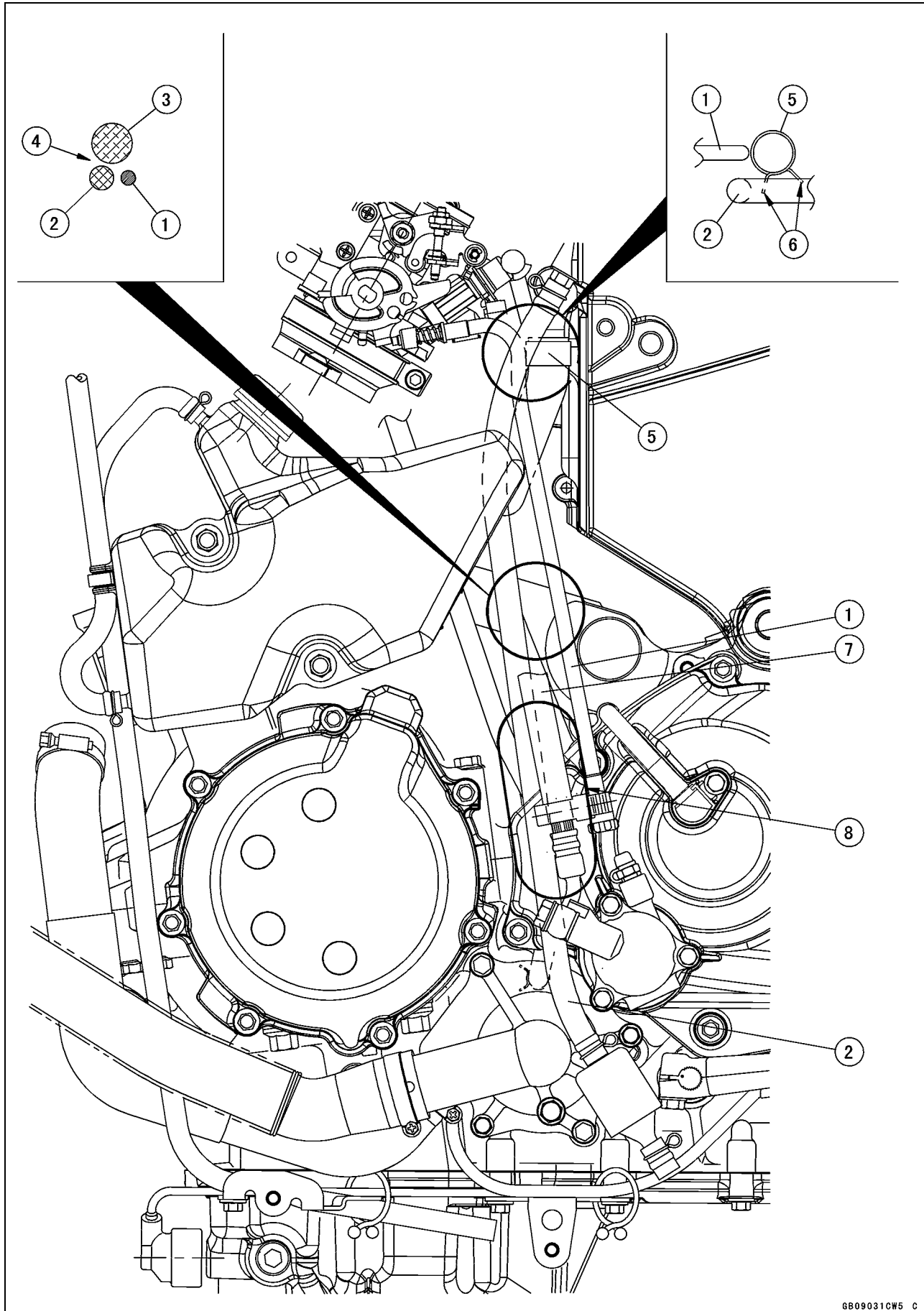

Cable, Wire, and Hose Routing

1. Idle Adjusting Screw
2. Through the air cleaner drain hose to the front of the clamp.
3. Main Harness
4. Through the air cleaner drain hose and idle adjusting screw to the outside of the main harness.
5. Clamp
6. Position the clamp so that its pinch heads do not touch the frame and air cleaner drain hose.
7. Clutch Hose
8. Through the air cleaner drain hose to the backside of the clutch hose.

17-6 APPENDIX

Cable, Wire, and Hose Routing

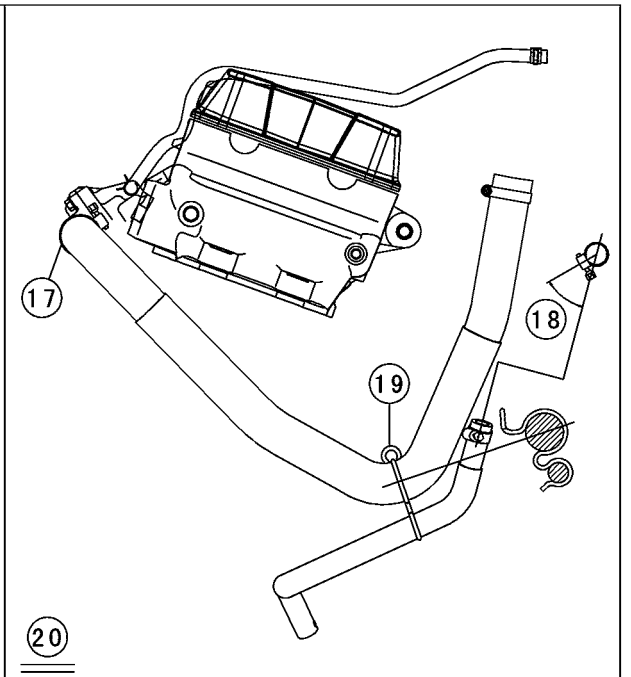
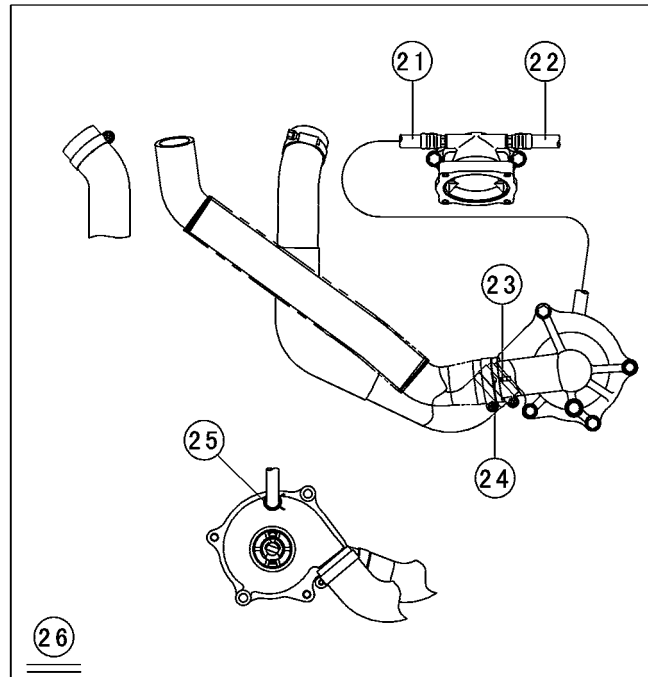
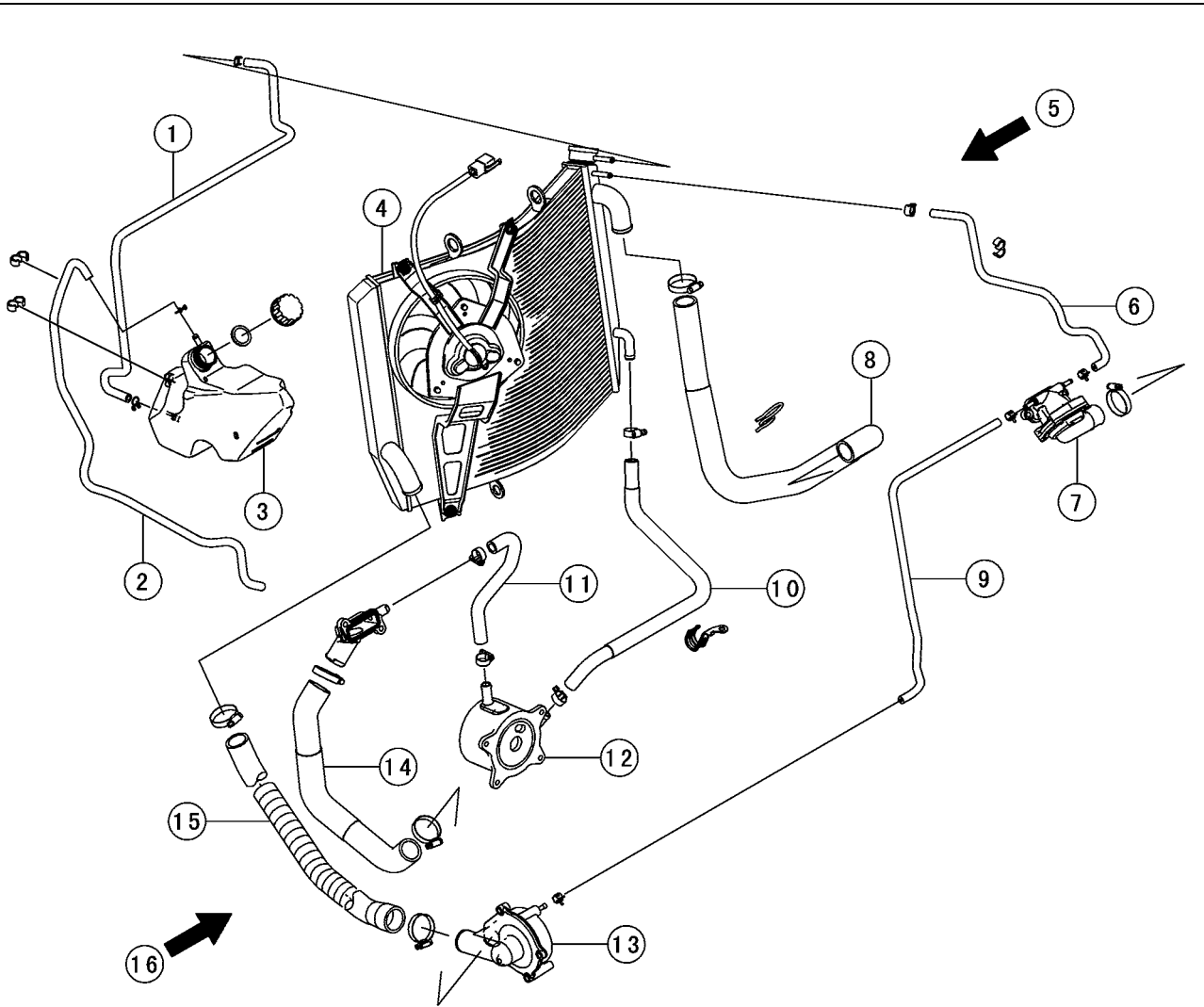

Cable, Wire, and Hose Routing

1. Reserver Tank Hosel
2. Reserver Tank Overflow Hose
3. Reserver Tank
4. Radiator
5. Right View
6. Air Bleeder Hose for Thermostat Housing
7. Thermostat Housing
8. Hose
9. Air Bleeder Hose for Water Pump
10. Outlet Hose
11. Inlet Hose
12. Oil Cooler
13. Water Pump
14. Hose
15. Hose
16. Left View
17. Align the white paint of the hose and mark of the thermostat housing cover.
18. About 45°
19. Clamp
20. Right View
21. Air Bleeder Hose for Water Pump
22. Air Bleeder Hose for Thermostat Housing
23. Align the white paint of the hose and mark of the water pump.
24. Install the hose so that white paint of the hose faces the front side.
25. Insert the air bleeder hose so that straight to the center of the impeller shaft.
26. Left View

17-8 APPENDIX

Cable, Wire, and Hose Routing

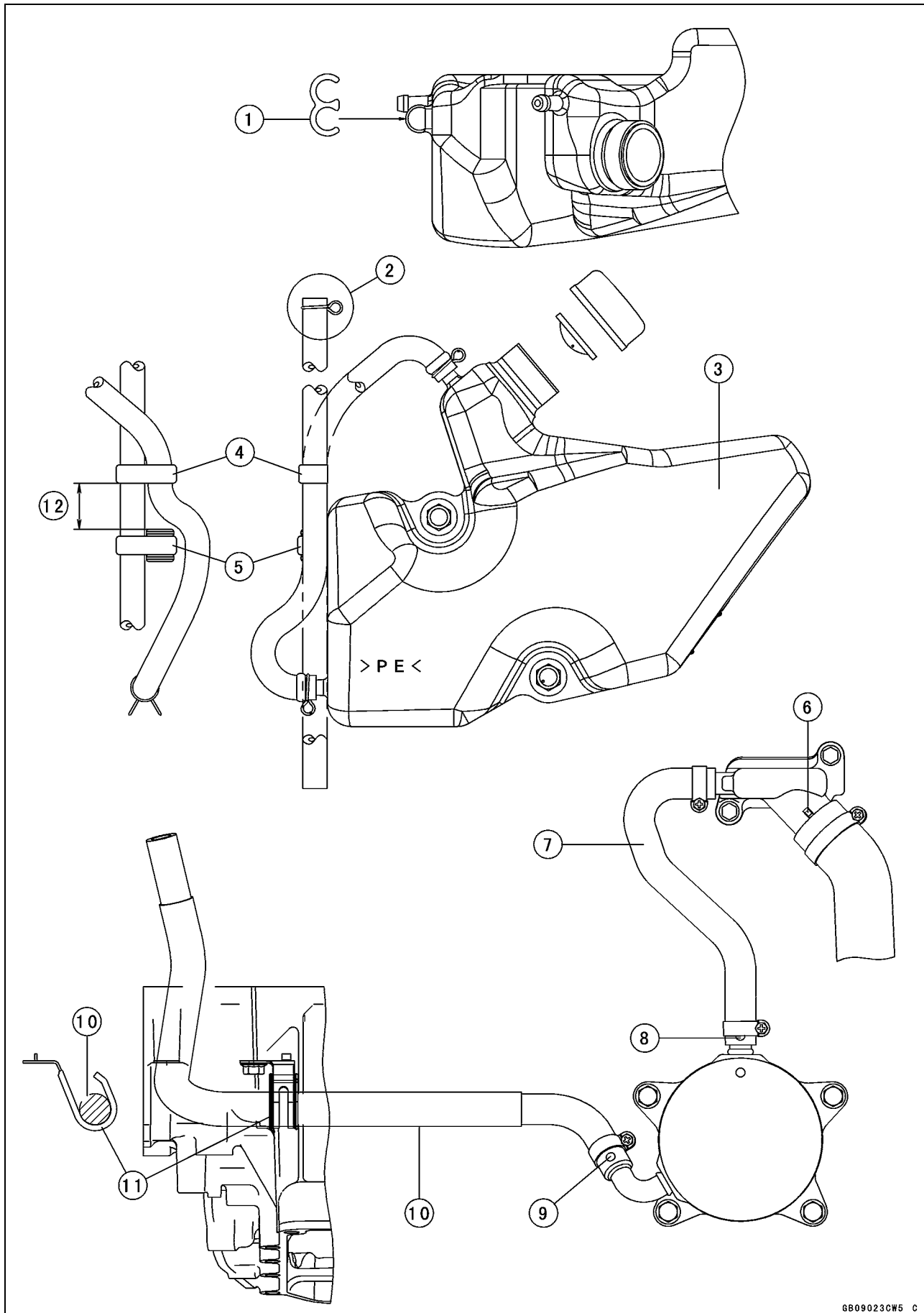

Cable, Wire, and Hose Routing

1. Clamp
2. Install the clamp so that knob of the clamp faces right side of the frame as shown in the figure.
3. Reserver Tank
4. Clamp
5. Clamp
6. Install the hose until projection.
7. Inlet Hose
8. Install the hose so that white paint of the hose faces the front side.
9. Install the hose so that white paint of the hose faces the front side.
10. Outlet Hose
11. Clamp
12. Approx. 20 mm (0.79 in.)

17-10 APPENDIX

Cable, Wire, and Hose Routing

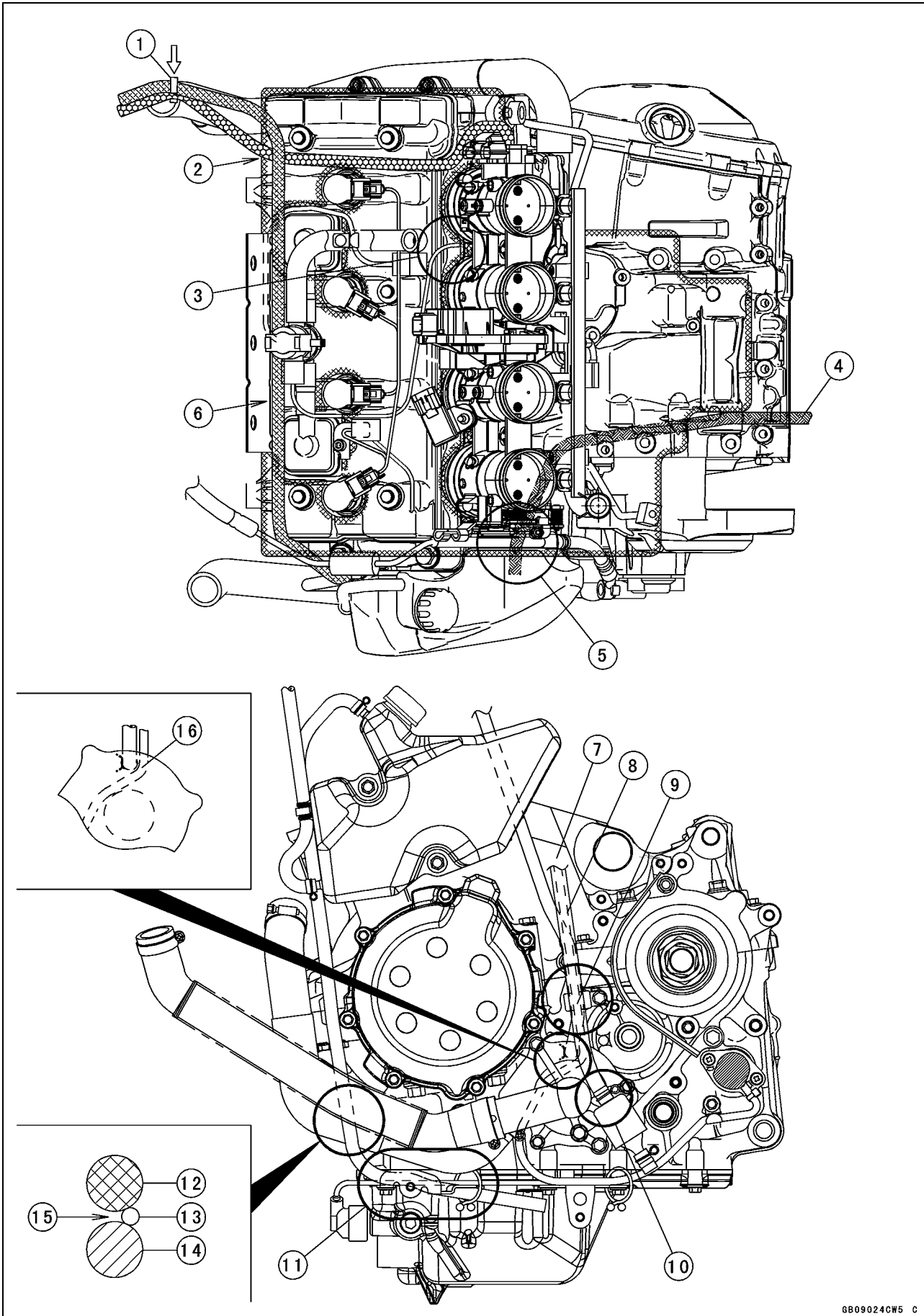

Cable, Wire, and Hose Routing

1. Clamp (Install the clamp from the arrow mark side.)
2. Through the reserver tank hose on the air bleeder hose for thermostat housing.
3. Through the subharness for sensor and valve between the #3 and #4 of the throttle body.
4. Alternator Lead (To the regulator/rectifier connector through the alternator subharness.)
5. Through the alternator lead backside of the air bleeder hose for water pump.
6. Through the reserver tank hose between the air switching valve and bracket.
7. Connect the gear position switch lead and sidestand switch lead to the main harness.
8. Air Cleaner Drain Hose
9. Through the air cleaner drain hose between the engine sprocket cover and clutch hose.
10. Through the air cleaner drain hose on the water pump, put in the space of the lower fairing.
11. Through the reserver tank overflow hose into the fairing bracket, and through the hose into the clamp.
12. Hose
13. Reserver Tank Overflow Hose
14. Hose
15. Through the reserver tank overflow hose between the hose and hose.
16. Through the gear position switch lead backside of the air bleeder hose for water pump.

17-12 APPENDIX

Cable, Wire, and Hose Routing

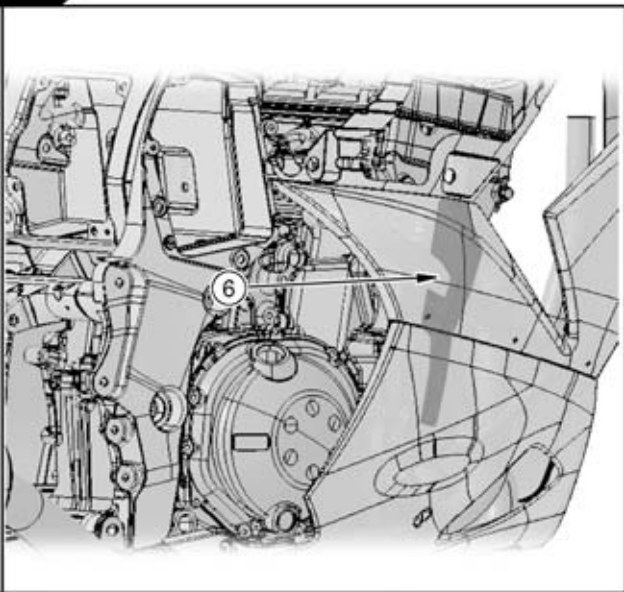
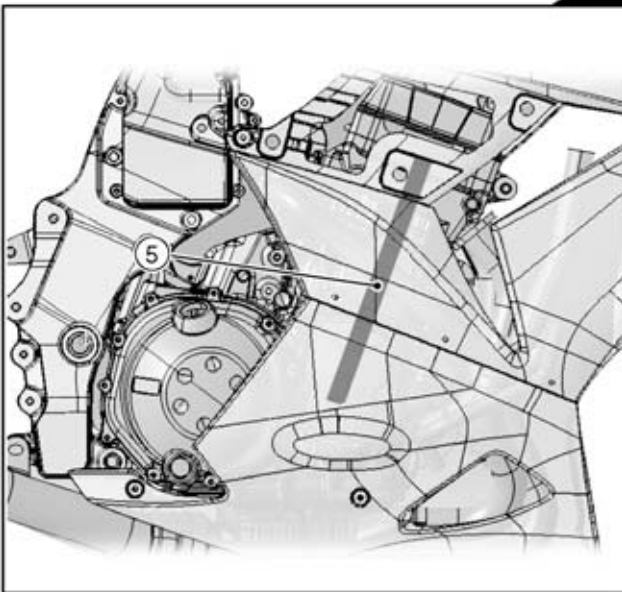
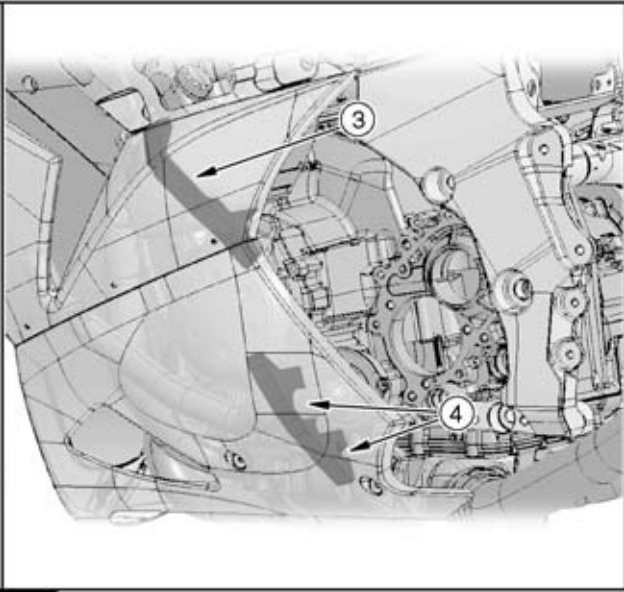
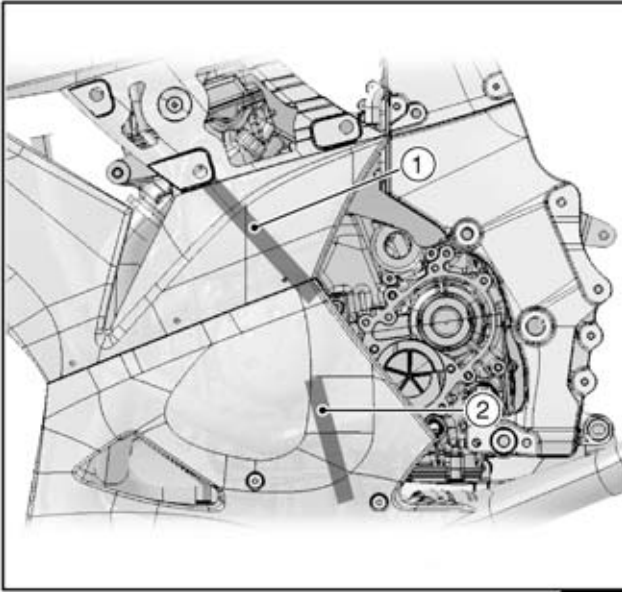

Cable, Wire, and Hose Routing

1. Pad
2. Pad
3. Fit the groove of the pad to the reserver tank, and fix the pad by the middle fairing.
4. Fit the grooves of the pad to the radiator hose and reserver tank drain hose, and fix the pad by the lower fairing.
5. Pad
6. Fit the groove of the pad to the radiator hose, and fix the pad by the middle fairing.

17-14 APPENDIX

Cable, Wire, and Hose Routing

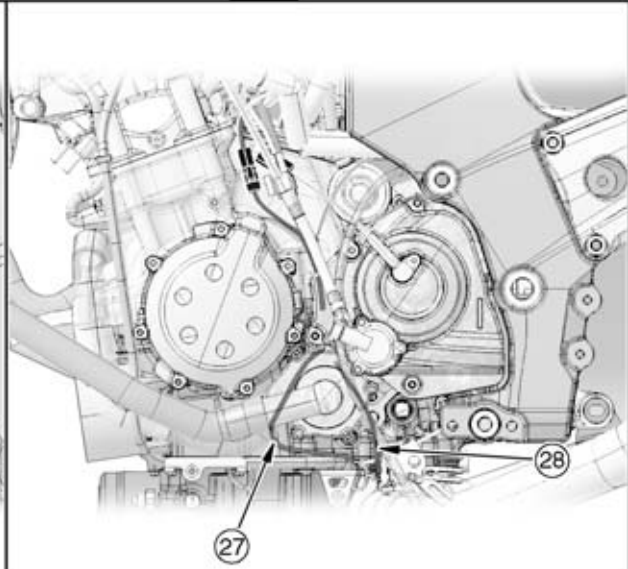
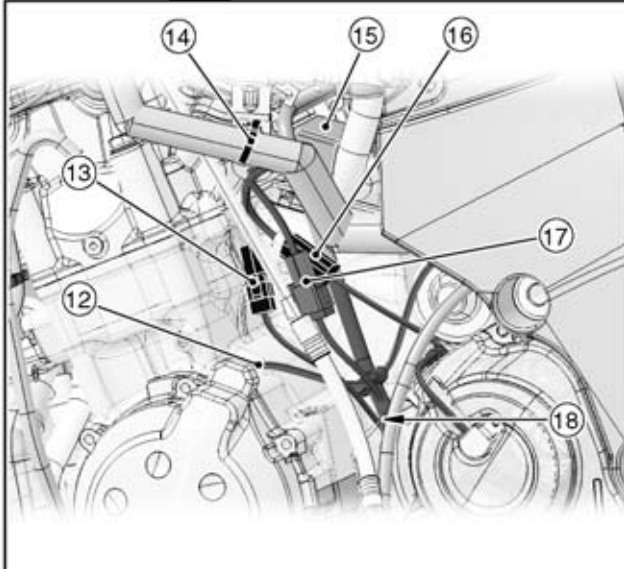
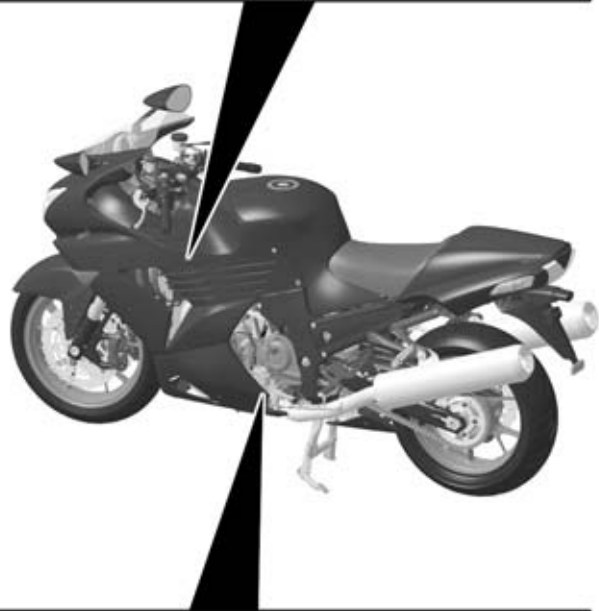
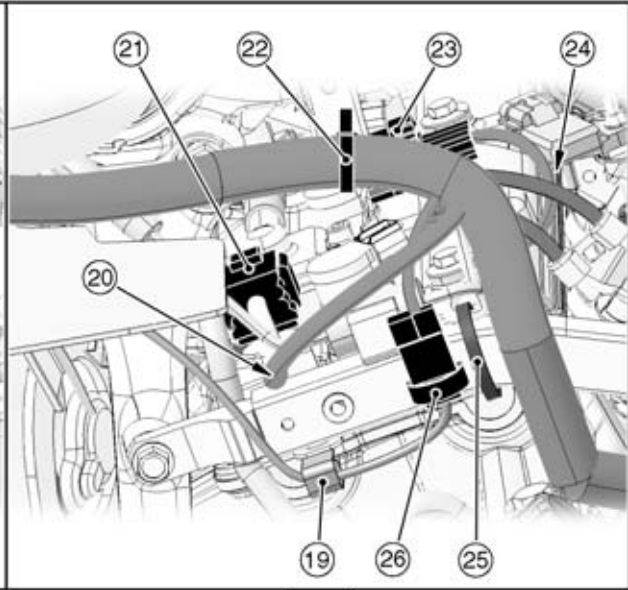
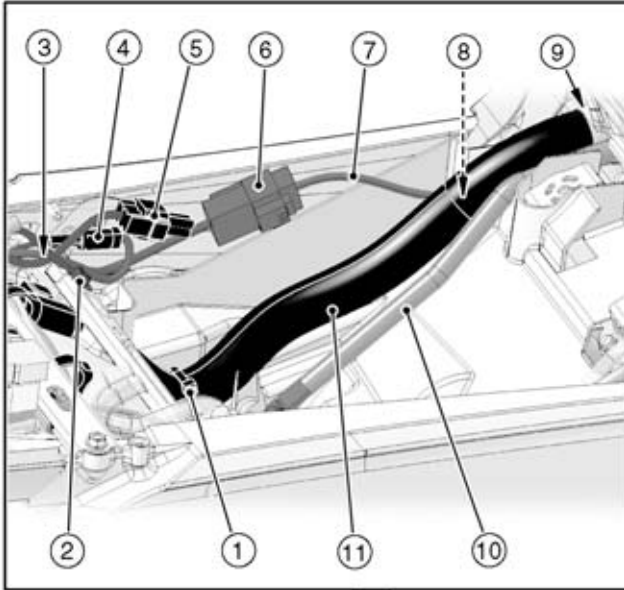

Cable, Wire, and Hose Routing

1. Band (Clamp the main harness, and insert the band to the rear fender.)
2. Frame Ground Lead (Tighten the bolt with lead and bracket.)
3. Through the alternator subharness to the outside of the frame ground lead.
4. Alternator Connector (Install the alternator connector to the bracket.)
5. Connector (Insert the connector to the bracket.)
6. Alternator Subharness (Put the alternator subharness between the rear fender and frame.)
7. Alternator Lead
8. Through the alternator lead under the main harness.
9. Align the gray tape and the end of the battery case.
10. Fuel Hose
11. Main Harness
12. Alternator Lead (Through the alternator lead to the inside of the leads and hose.)
13. Sidestand Switch Lead Connector
14. Band (Clamp the main harness, and insert the band to the bracket.)
15. Throttle Body Subharness Connector (Install the connector to the bracket.)
16. Speed Sensor Lead Connector
17. Oil Pressure Switch/Gear Position Switch Lead Connector
18. Through the sidestand switch lead and oil pressure switch/gear position switch lead to the inside of the chain cover from the hole of the notch.
19. Clamp (Clamp the fan motor lead.)
20. Through the engine harness to the outside of the clutch hose.
21. Engine Harness Connector (Install the engine harness connector to the bracket.)
22. Band (Clamp the main harness, and insert the band to the bracket.)
23. Stick Coil Lead Connector (Install the stick coil lead connector to the bracket of the cylinder head cover.)
24. Through the stick coil lead under the throttle cables.
25. Band (Clamp the engine harness with the subframe.)
26. Clamp (Clamp the fan motor lead connector, and insert the clamp to the subframe.)
27. Through the oil pressure switch/gear position switch lead to the inside of the water pump.
28. Through the sidestand switch lead to the inside of the water pump.

17-16 APPENDIX

Cable, Wire, and Hose Routing

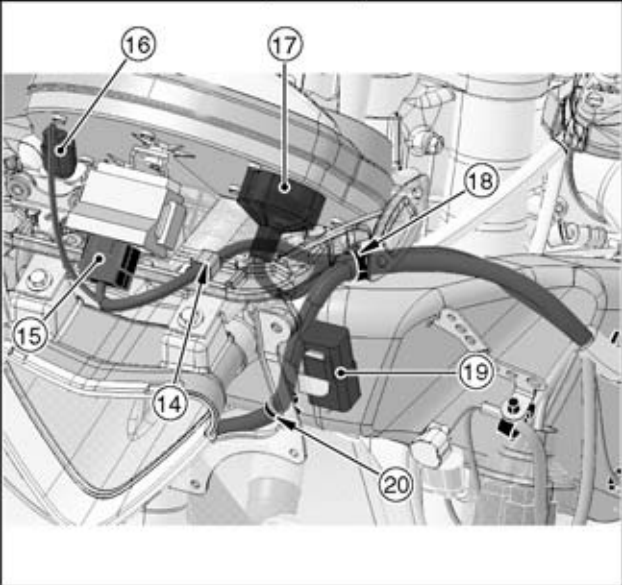
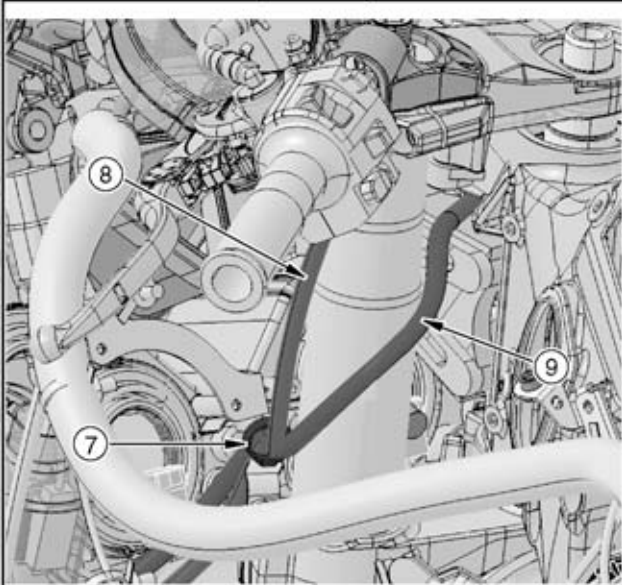
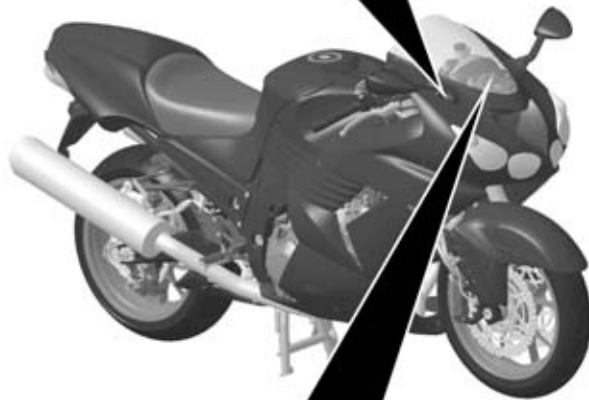
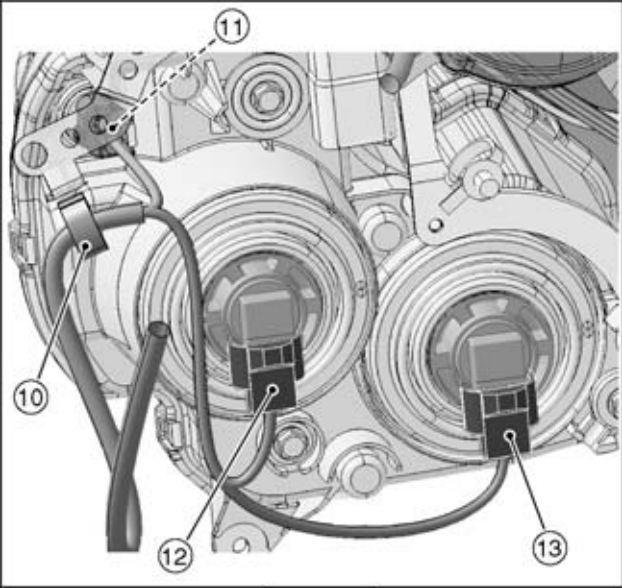
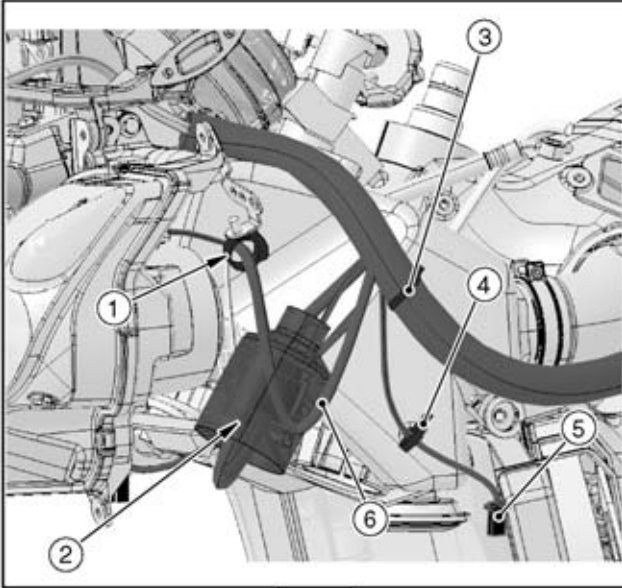

Cable, Wire, and Hose Routing

1. Through the headlight lead into the clamp (both sides).
2. After ignition switch lead connector and left switch housing lead connector connecting, put the connectors in the water-proof cover.
3. Clamp (Clamp the main harness, and insert the clamp to the middle air inlet duct.)
4. Clamp (Clamp the left turn signal lead, and insert the clamp to the middle air inlet duct.)
5. Left Turn Signal Light Lead Connector
6. Headlight Lead
7. Through the left switch housing lead and ignition switch lead into the clamp, and insert the clamp to the bracket.
8. Through the left switch housing lead to the outside of the front fork, and through the lead into the clamp.
9. Through the ignition switch lead to the backside of the front fork from the inside of the front fork, and through the lead into the clamp.
10. Clamp
11. Left City Light
12. Headlight (High)
13. Headlight (Low)
14. Install the clamp outside as shown in the figure, and clamp the immobilizer amplifier lead.
15. Immobilizer Amplifier Lead Connector
16. Vehicle-down Sensor Lead Connector
17. Meter Unit Lead Connector
18. Through the main harness and immobilizer amplifier lead into the clamp.
19. Headlight Relay (High)
20. Clamp (Clamp the main harness, and insert the clamp to the middle air inlet duct.)

17-18 APPENDIX

Cable, Wire, and Hose Routing

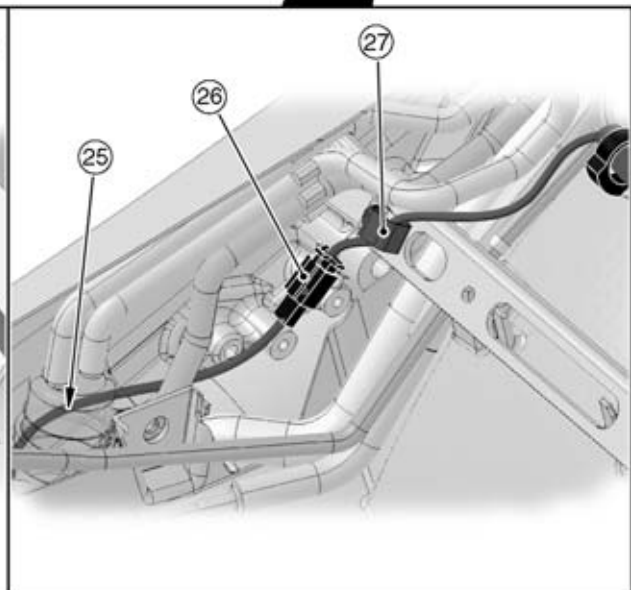
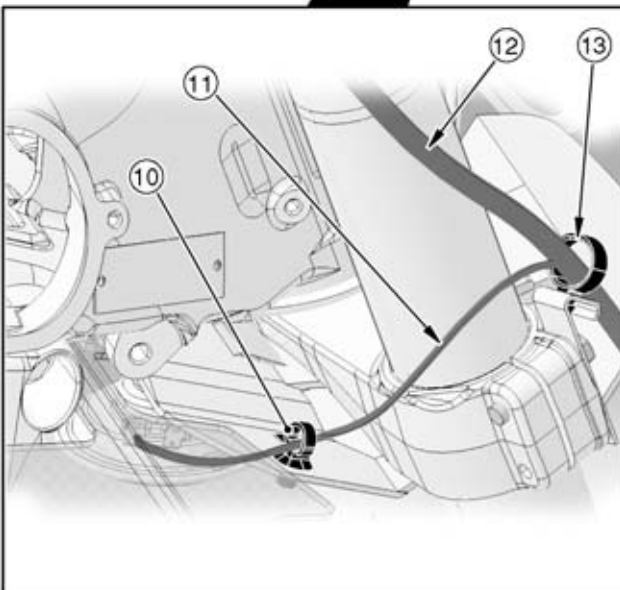
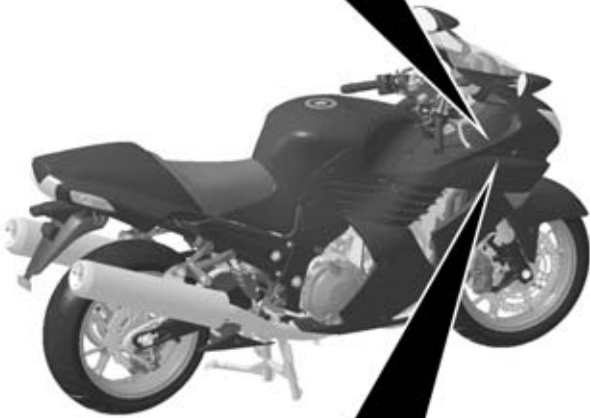
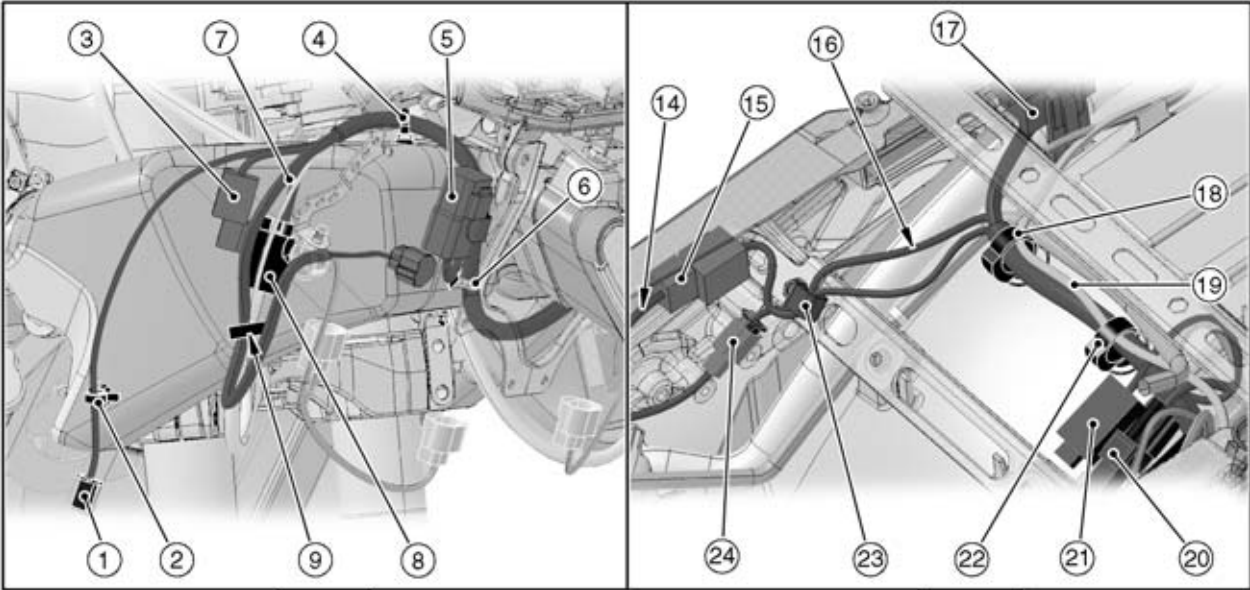

Cable, Wire, and Hose Routing

1. Right Turn Signal Light Lead Connector
2. Clamp (Clamp the right turn signal lead, and insert the clamp to the middle air inlet duct.)
3. *Front Wheel Rotation Sensor Lead Connector
4. Clamp (Clamp the main harness, and insert the clamp to the middle air inlet duct.)
5. Headlight Relay (Low)
6. Clamp (Clamp the main harness, and insert the clamp to the middle air inlet duct.)
7. Right Switch Housing Lead and Horn Lead
8. Right Switch Housing Lead Connector
9. Through the right switch housing lead, horn lead, headlight lead and *front wheel rotation sensor lead into the clamp.
10. Clamp (Clamp the horn lead, and insert the clamp to the cover.)
11. Through the horn lead to the outside of the front fork.
12. Through the right switch housing lead to the outside of the front fork.
13. Through the right switch housing lead and horn lead into the clamp.
14. Through the rear wheel rotation sensor lead to the inside of the rear brake reservoir tank.
15. *Front Wheel Rotation Sensor Lead Connector (Install the front wheel rotation sensor lead connector to the bracket.)
16. Through the main harness lead on the rear brake reservoir tank hose.
17. Fuse Box 1
18. Clamp
19. Alternator Subharness
20. Fuel Pump Lead Connector
21. Fuel Level Sensor Lead Connector
22. Clamp
23. Clamp (Clamp the rear brake light switch lead and *rear wheel rotation sensor lead.)
24. Rear Brake Light Switch Lead Connector
25. Through the rear brake light switch lead to the outside of the separator.
26. Rear Brake Light Switch Lead Connector
27. Clamp (Clamp the rear brake light switch lead.)

* ZX1400B Models only

17-20 APPENDIX

Cable, Wire, and Hose Routing

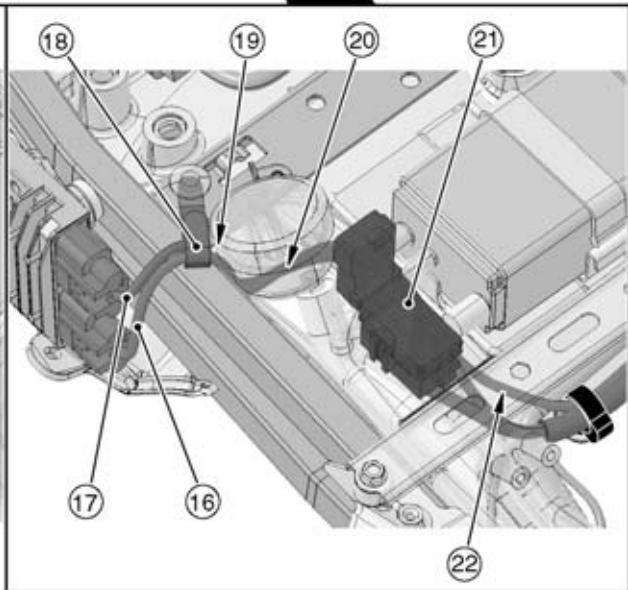
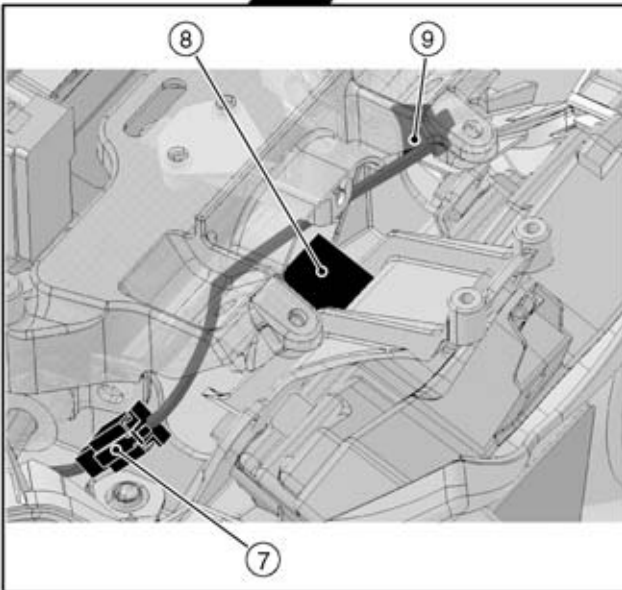
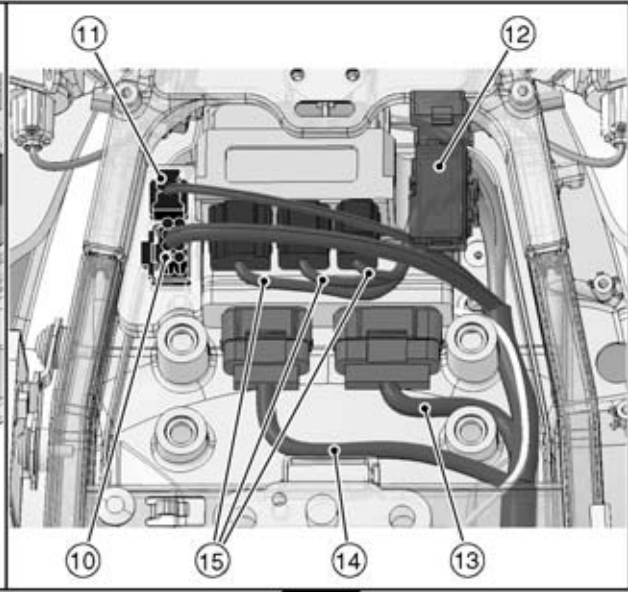
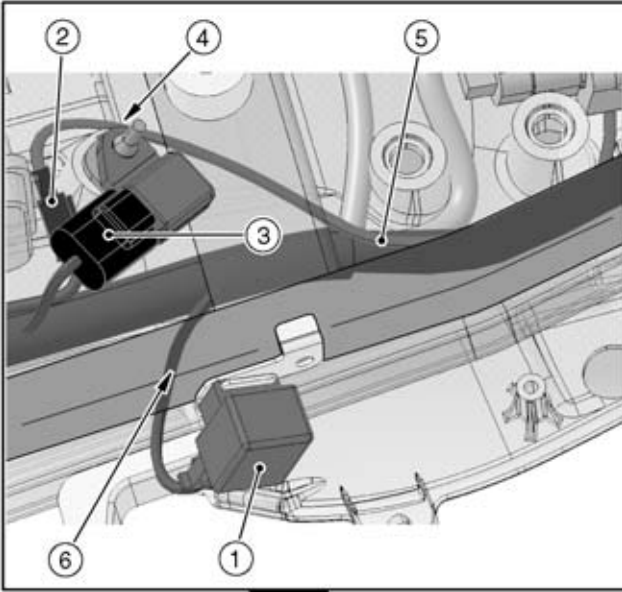

Cable, Wire, and Hose Routing

1. Turn Signal Relay
2. License Plate Light Lead Connector
3. Atmospheric Pressure Sensor Lead Connector
4. Through the license plate light lead to the inside of the atmospheric pressure sensor.
5. License Plate Light Lead
6. Through the turn signal relay lead between the rear frame and rear frame pipe.
7. Rear Left Turn Signal Light Lead Connector
8. Tail/Brake Light Lead Connector
9. Rear Right Turn Signal Light Lead Connector
10. *ABS Kawasaki Self-diagnosis System Connector (Fix the ABS Kawasaki self-diagnosis system connector with the sponge.)
11. Immobilizer/Kawasaki Diagnostic System Connector (Fix the Immobilizer/Kawasaki diagnostic system connector with the sponge.)
12. Fuse Box 2
13. ECU Lead
14. ECU Lead
15. Relay Box Leads
16. Alternator Subharness
17. Alternator Lead
18. Clamp (Clamp the alternator lead and alternator subharness.)
19. Through the alternator lead and alternator subharness to the outside of the rear frame.
20. Through the alternator lead and alternator subharness under the rear brake reservoir tank.
21. Fuse Box 1
22. Through the alternator subharness under the bracket.

* ZX1400B Models only

17-22 APPENDIX

Cable, Wire, and Hose Routing

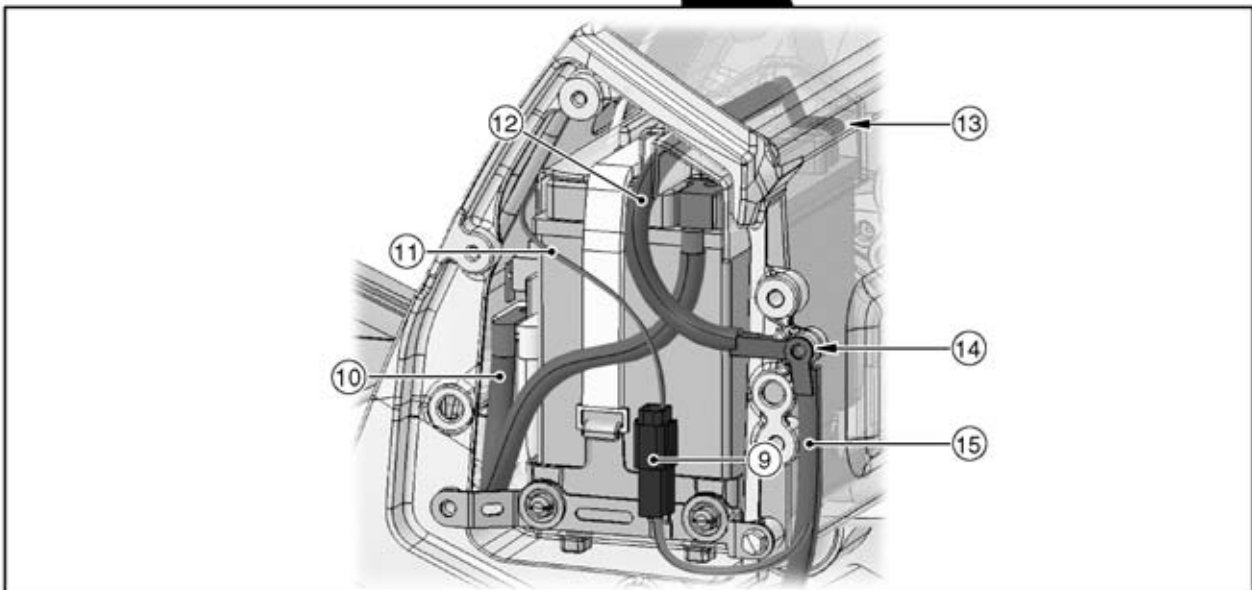
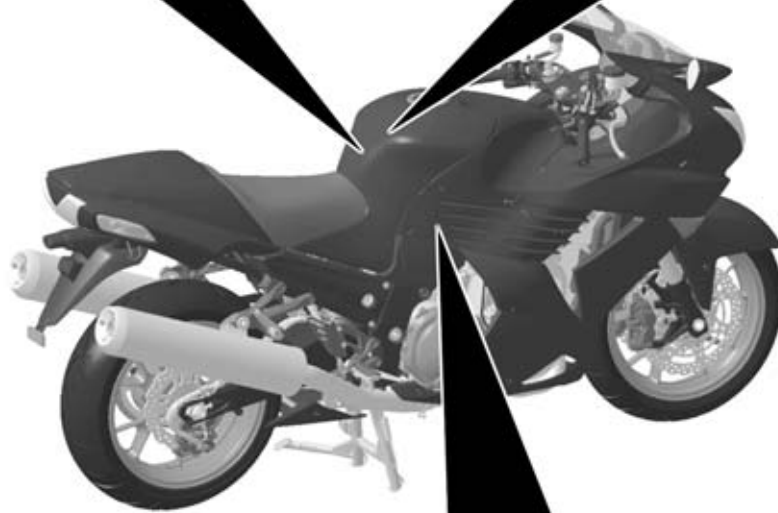
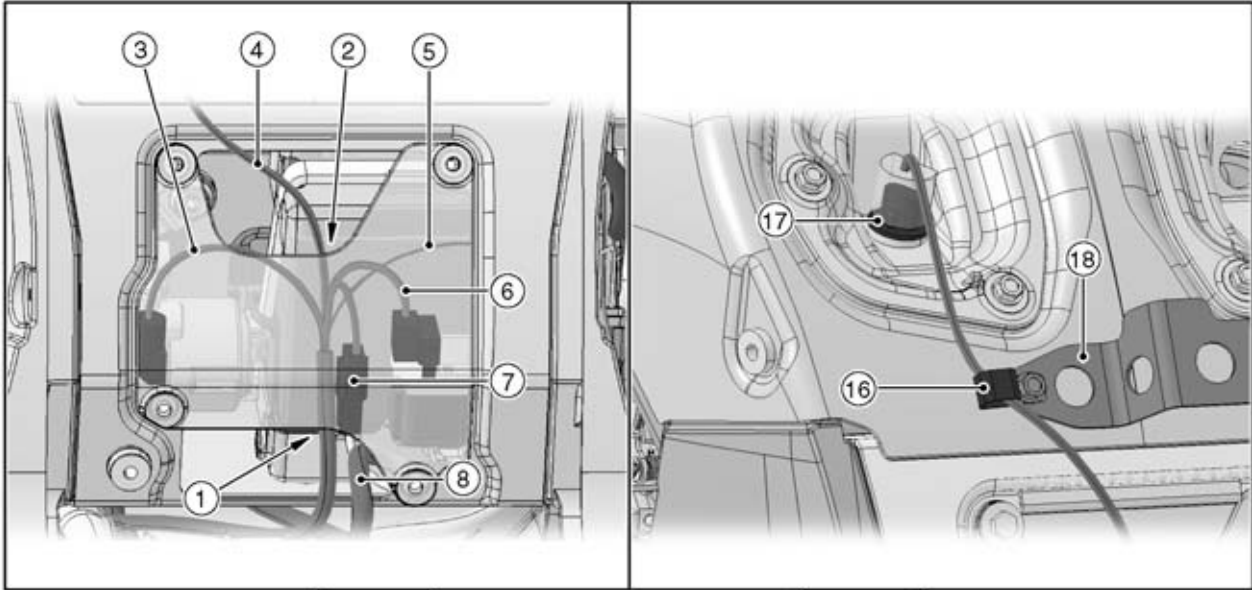

Cable, Wire, and Hose Routing

1. Through the main harness to the hole of the lower side.
2. Through the inlet air temperature sensor lead to the hole of the upper side.
3. *ABS Hydraulic Unit Lead
4. Inlet Air Temperature Sensor Lead
5. Battery Negative Lead
6. Starter Relay Lead
7. Battery Positive Lead Connector (Install the battery positive lead connector to the battery case.)
8. Starter Motor Cable
9. Battery Negative Lead Connector (Install the battery negative lead connector to the bracket.)
10. Battery Positive Cable
11. Battery Negative Lead
12. Battery Negative Cable
13. Direction of Battery Negative Terminal Installation
14. Tighten the bolt with battery negative cable and battery negative lead.
15. Battery Negative Cable
16. Clamp (Clamp the inlet air temperature sensor lead.)
17. Inlet Air Temperature Sensor
18. *Bracket

* ZX1400B Models only

17-24 APPENDIX

Cable, Wire, and Hose Routing

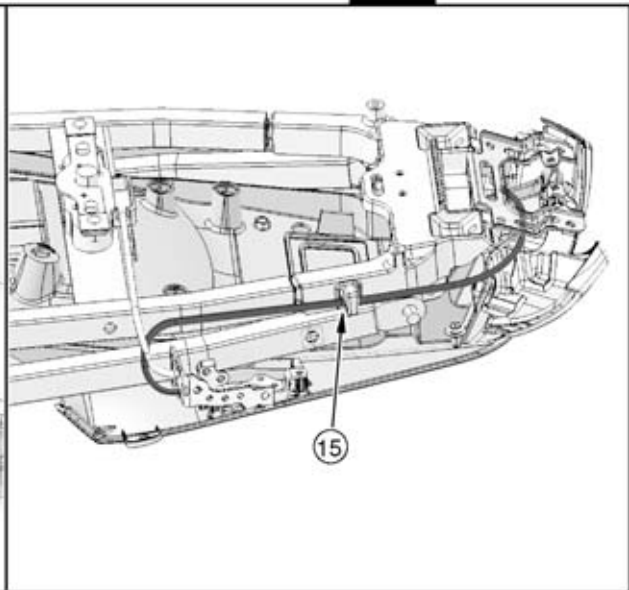
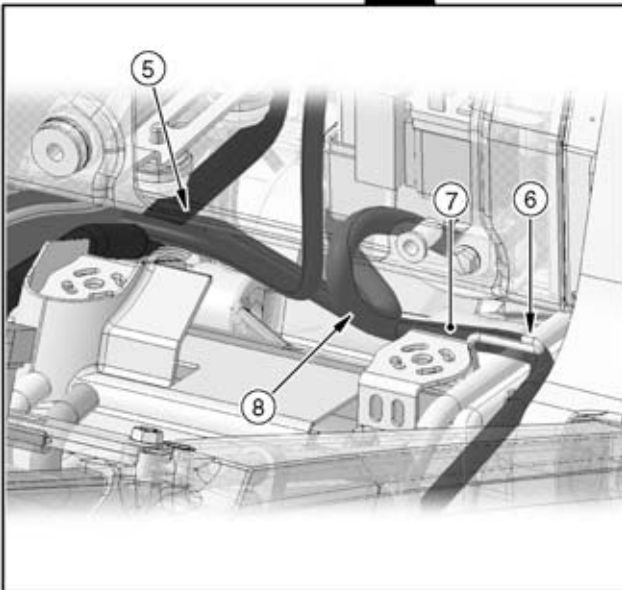
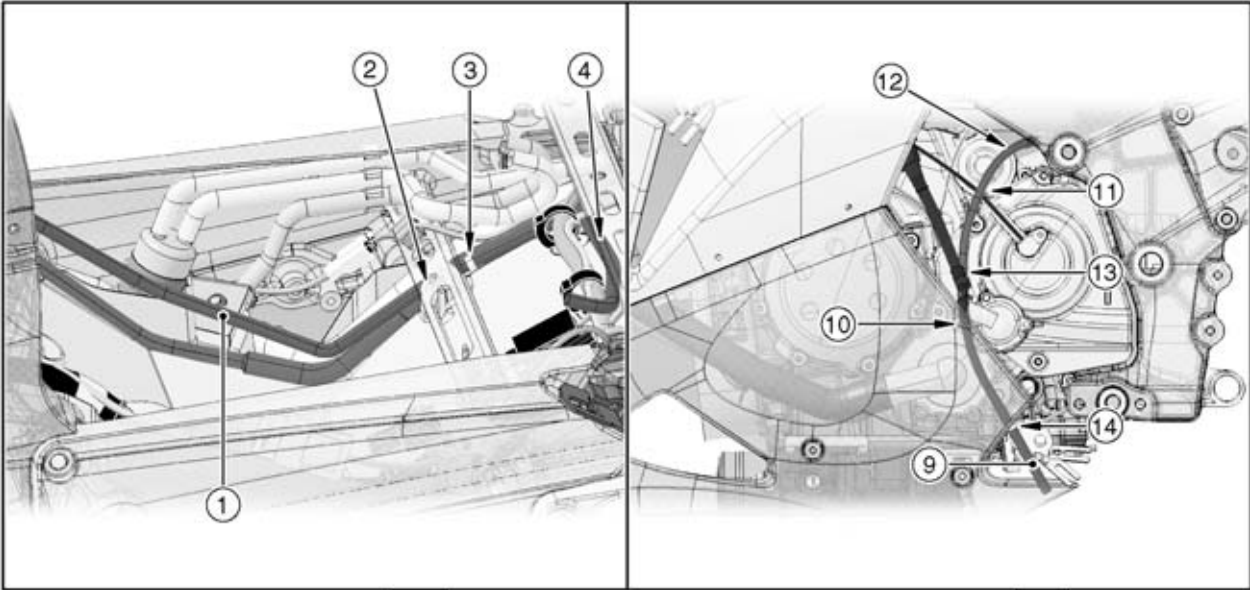

Cable, Wire, and Hose Routing

1. Fuel Tank Drain Hose
2. Through the fuel tank drain hose under the bracket.
3. Position a yellow tape at the rear end of bracket.
4. Through the fuel tank drain hose to the backside of the clamp.
5. Through the fuel tank drain hose under the fuel hose.
6. Through the fuel tank drain hose under the clamp.
7. Fuel Tank Drain Hose
8. Through the fuel tank drain hose under the starter motor cable.
9. Fuel Tank Drain Hose
10. Through the fuel tank drain hose under the lower fairing.
11. Through the fuel tank drain hose on the speed sensor lead.
12. Through the fuel tank drain hose under the heat insulation rubber plate.
13. Through the fuel tank drain hose under the clutch hose.
14. Position a yellow tape at the end of lower fairing.
15. Through the seat lock cable to the rear frame.

17-26 APPENDIX

Cable, Wire, and Hose Routing

ZX1400B Models

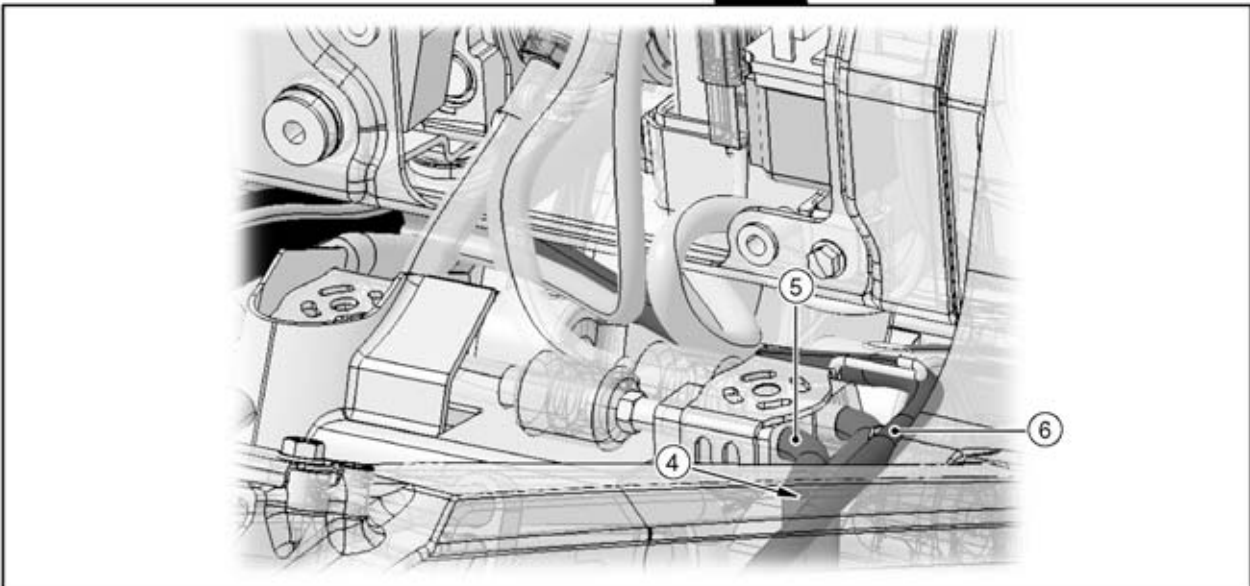
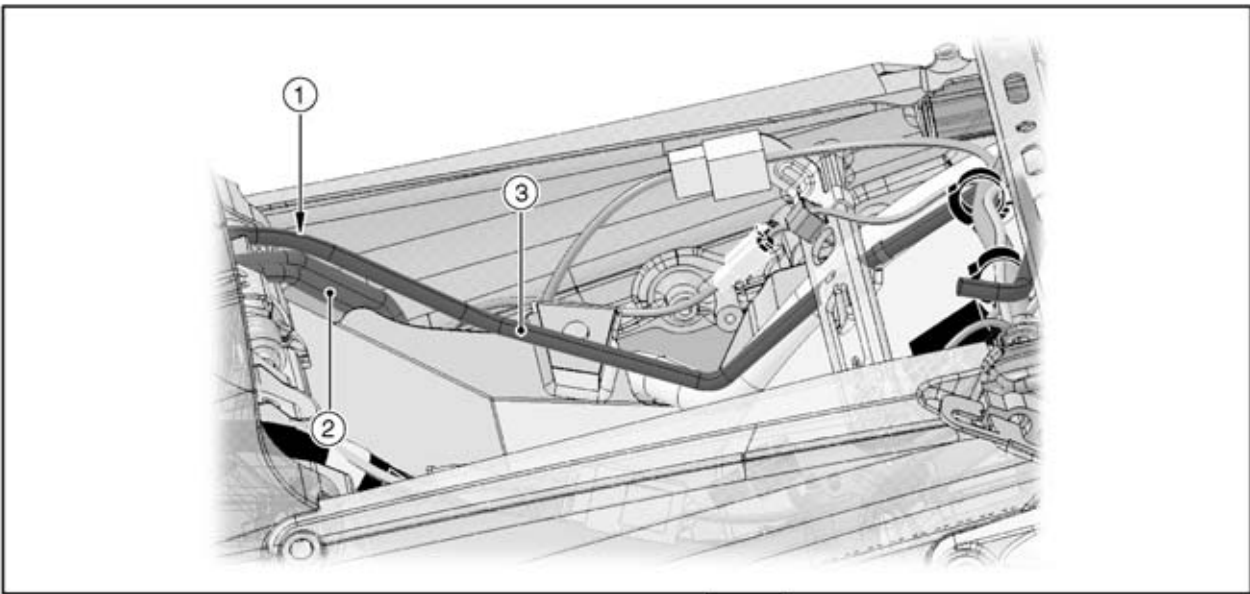

Cable, Wire, and Hose Routing

1. Through the fuel tank drain hose on the brake pipe.
2. Brake Pipe
3. Fuel Tank Drain Hose
4. Through the fuel tank drain hose on the brake pipe.
5. Brake Pipe
6. Fuel Tank Drain Hose

17-28 APPENDIX

Cable, Wire, and Hose Routing

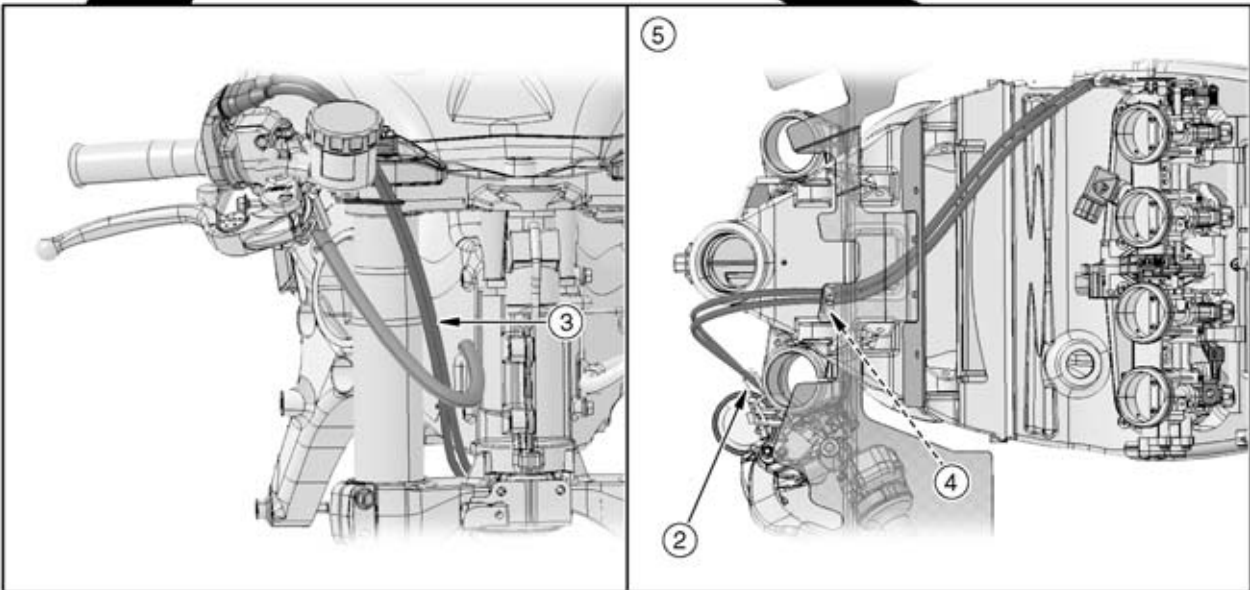
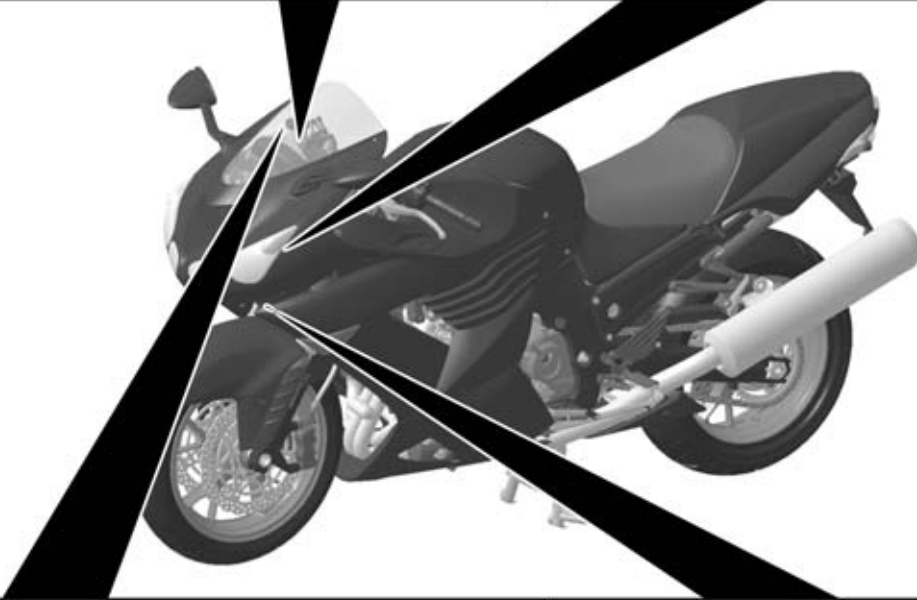
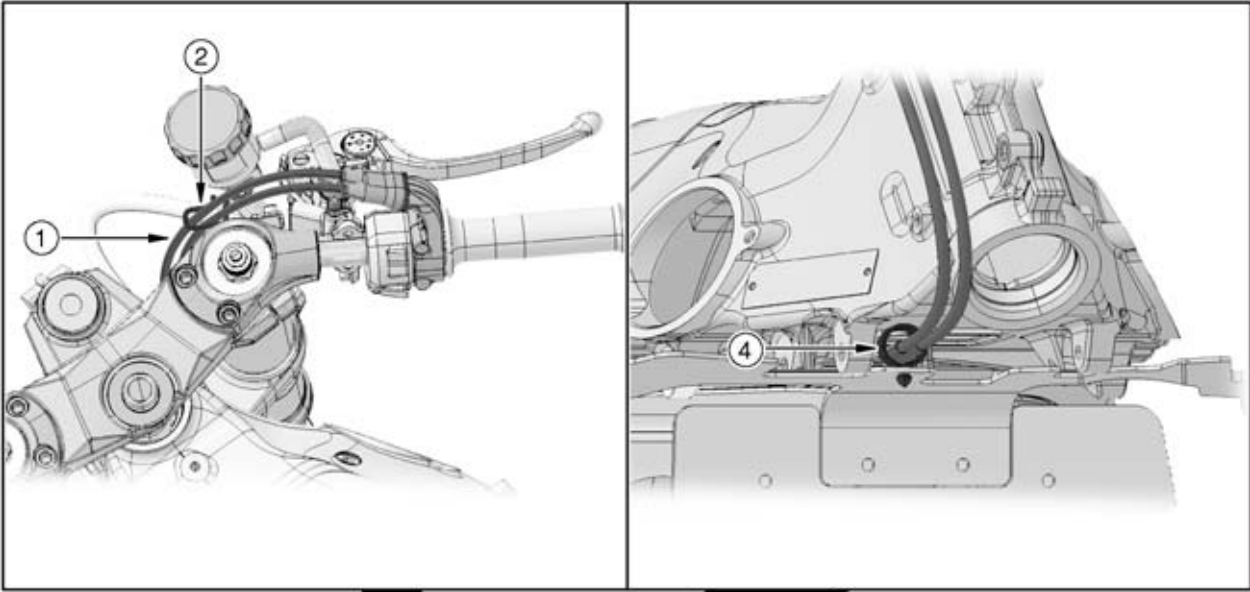

Cable, Wire, and Hose Routing

1. Through the throttle cables inside of the brake hose.
2. Through the throttle cables to the clamp of the reservoir bracket.
3. Through the throttle cables inside of the brake hose.
4. Through the throttle cables to the clamp.
5. Viewed Bottom

17-30 APPENDIX

Cable, Wire, and Hose Routing

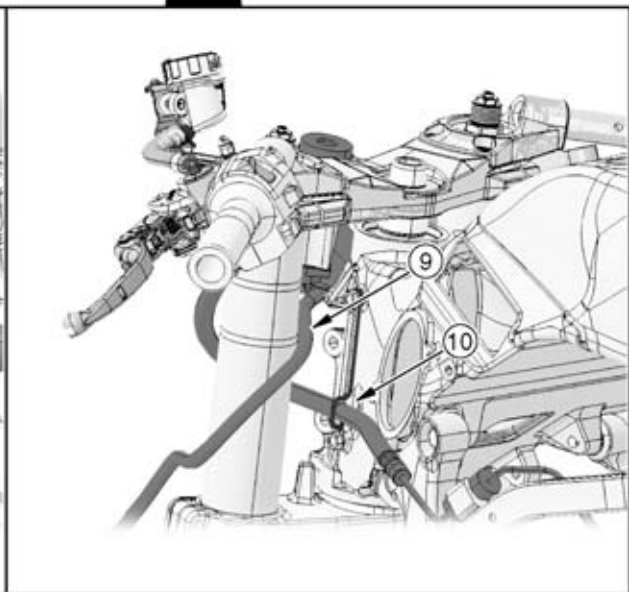
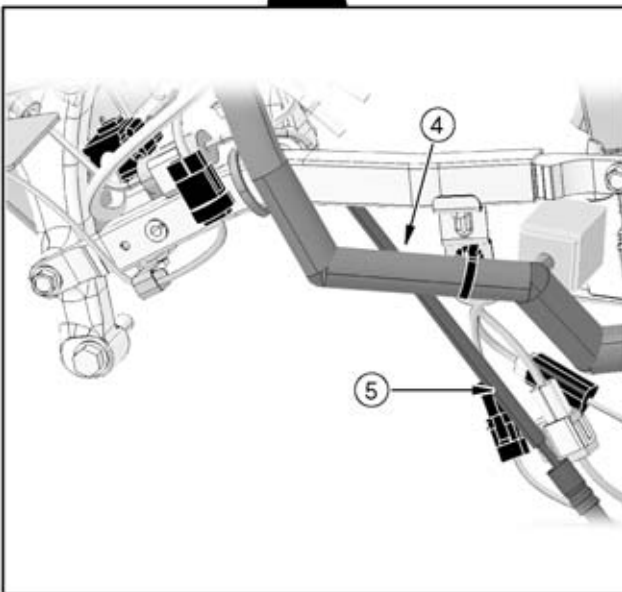
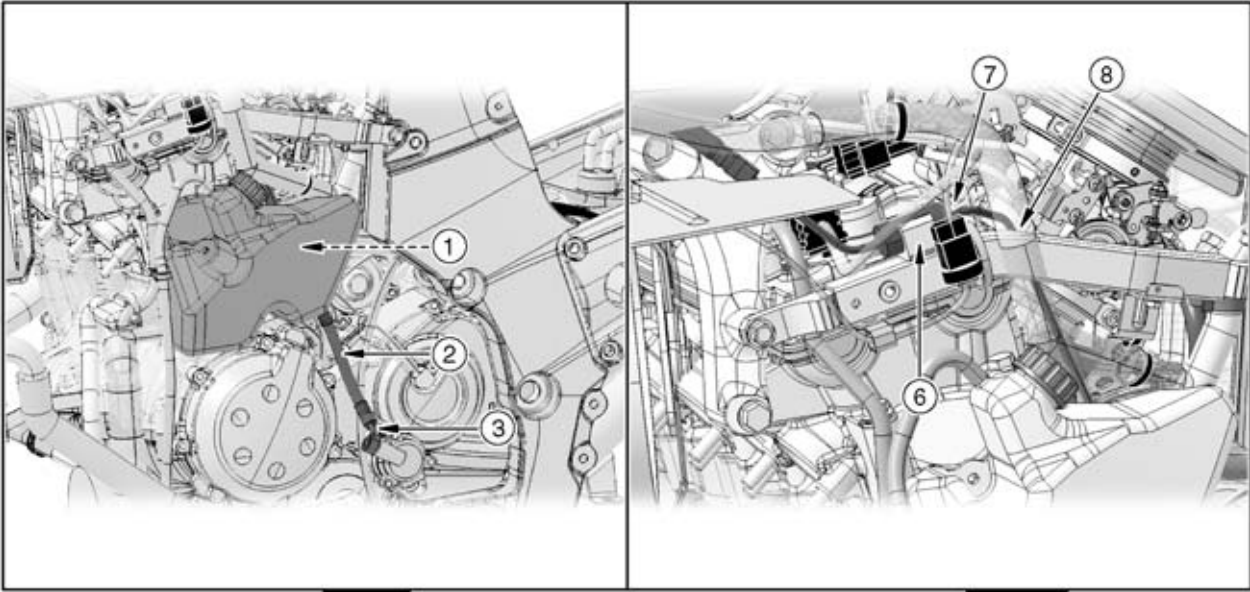

Cable, Wire, and Hose Routing

1. Through the clutch hose inside the coolant reserver tank.
2. Through the clutch hose outside the sidestand switch, speed sensor, oil pressure switch/gear position switch leads.
3. Install the cluth hose joint as shown in the figure (face the clutch hose joint pipe inside).
4. Through the clutch hose inside the main harness.
5. Through the clutch hose outside the sidestand switch, speed sensor and oil pressure switch/gear position switch lead connectors.
6. Clamp the clutch hose to the clamp of the subframe.
7. Through the clutch hose inside the radiator fan lead.
8. Through the clutch hose inside the subframe.
9. Through the ignition switch lead upper the clutch hose.
10. Through the clutch hose in the clamp.

17-32 APPENDIX

Cable, Wire, and Hose Routing

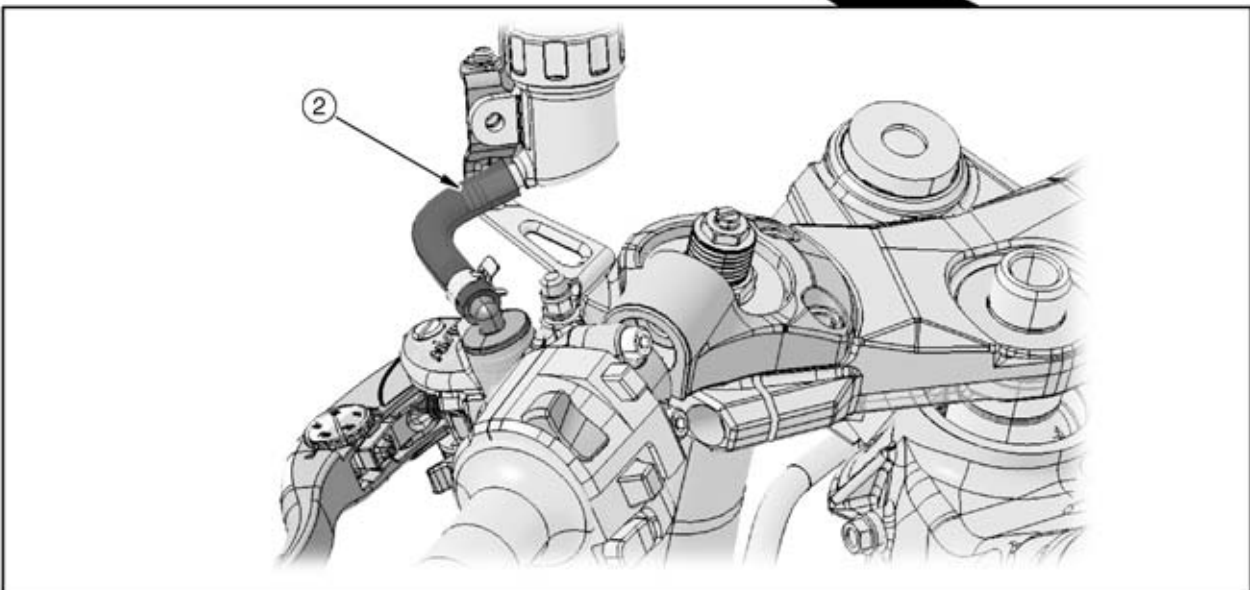
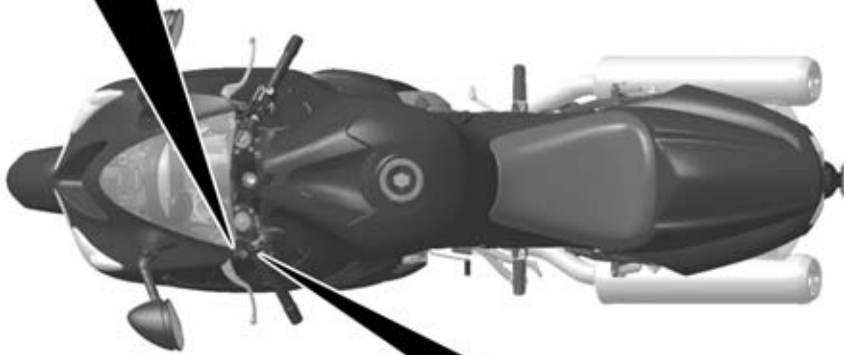
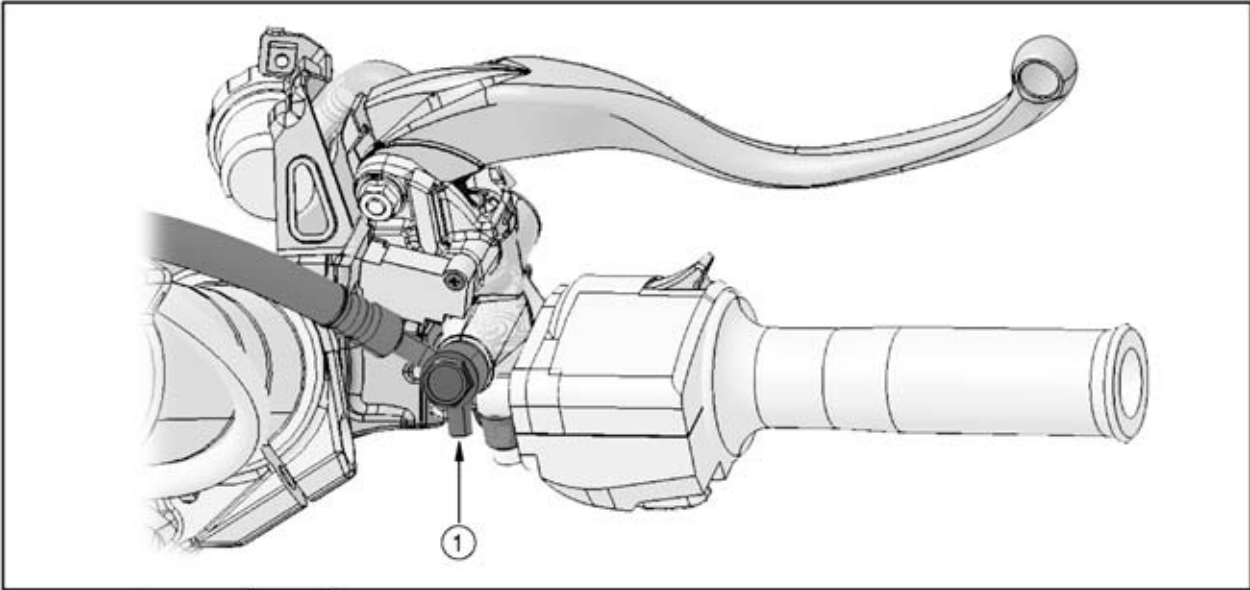

Cable, Wire, and Hose Routing

1. Install the clutch hose joint as shown in the figure (face the projection of the clutch hose joint backward).
2. Through the clutch fluid reservoir hose inside the bracket.

17-34 APPENDIX

Cable, Wire, and Hose Routing

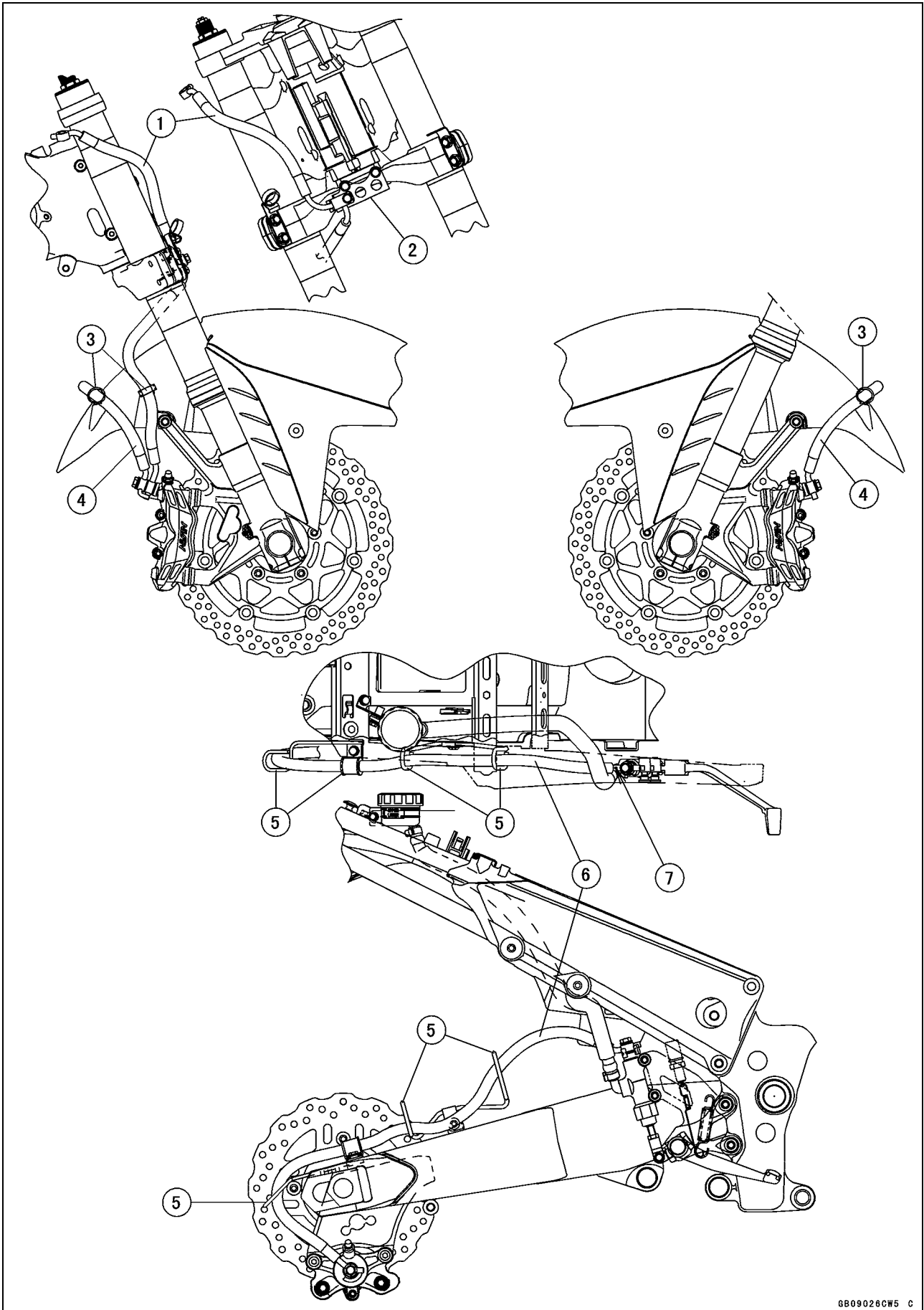

Cable, Wire, and Hose Routing

1. Brake Hose
2. Bracket
3. Clamps (Insert the clamps in the front fender.)
4. Brake Hose
5. Clamps
6. Brake Hose
7. Face the white paint mark upward.

17-36 APPENDIX

Cable, Wire, and Hose Routing

ZX1400B Models

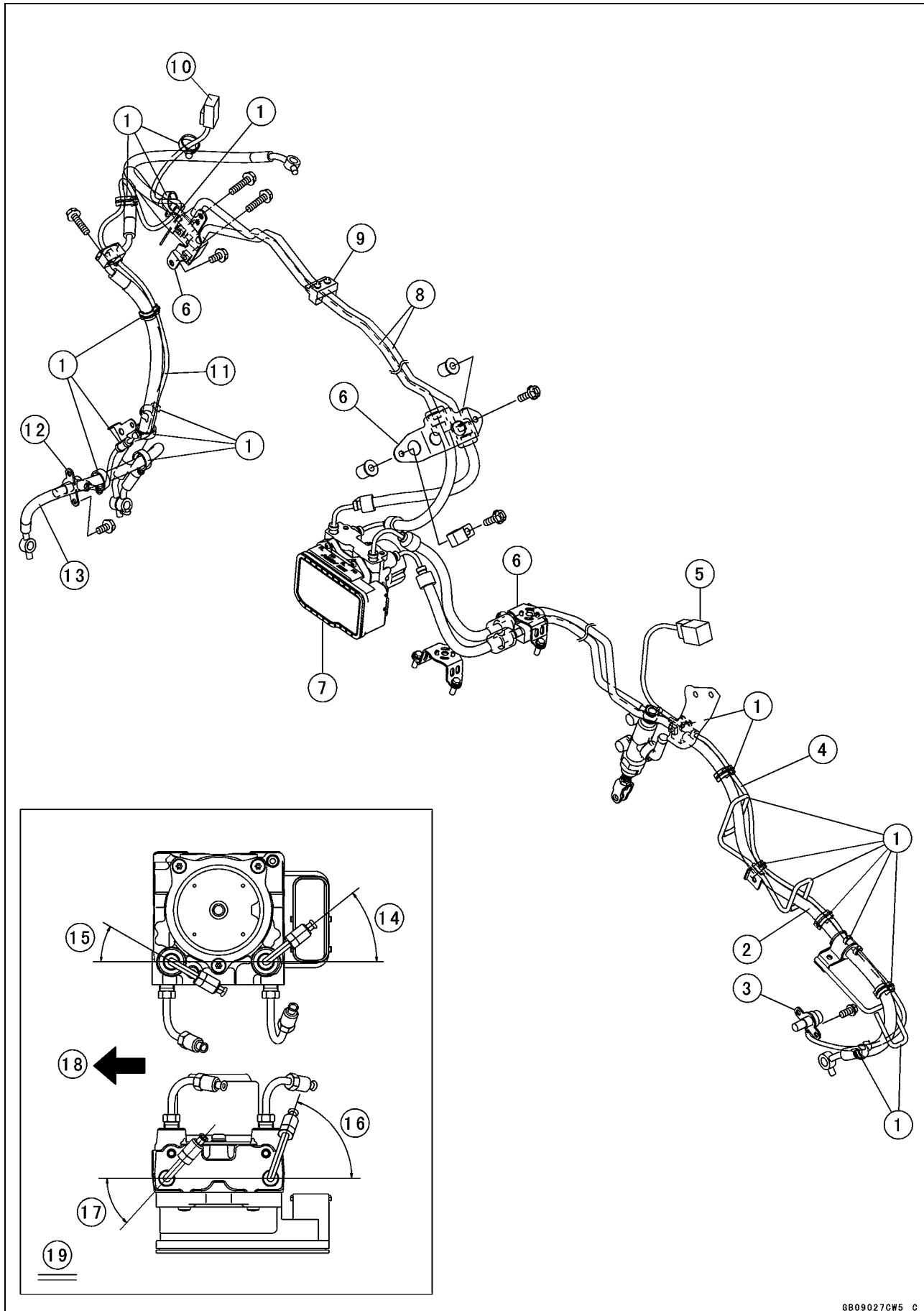

Cable, Wire, and Hose Routing

1. Clamps
2. Brake Hose
3. Rear Wheel Rotation Sensor
4. Rear Wheel Rotation Sensor Lead
5. Rear Wheel Rotation Sensor Lead Connector
6. Bracket
7. ABS Hydraulic Unit
8. Brake Pipes
9. Damper
10. Front Wheel Rotation Sensor Lead Connector
11. Front Wheel Rotation Sensor Lead
12. Front Wheel Rotation Sensor
13. Brake Hose
14. Approx. 38.5°
15. Approx. 30°
16. Approx. 71°
17. Approx. 48°
18. Front
19. Install the brake hose joint pipes as shown in the figure.

17-38 APPENDIX

Cable, Wire, and Hose Routing

ZX1400B Models

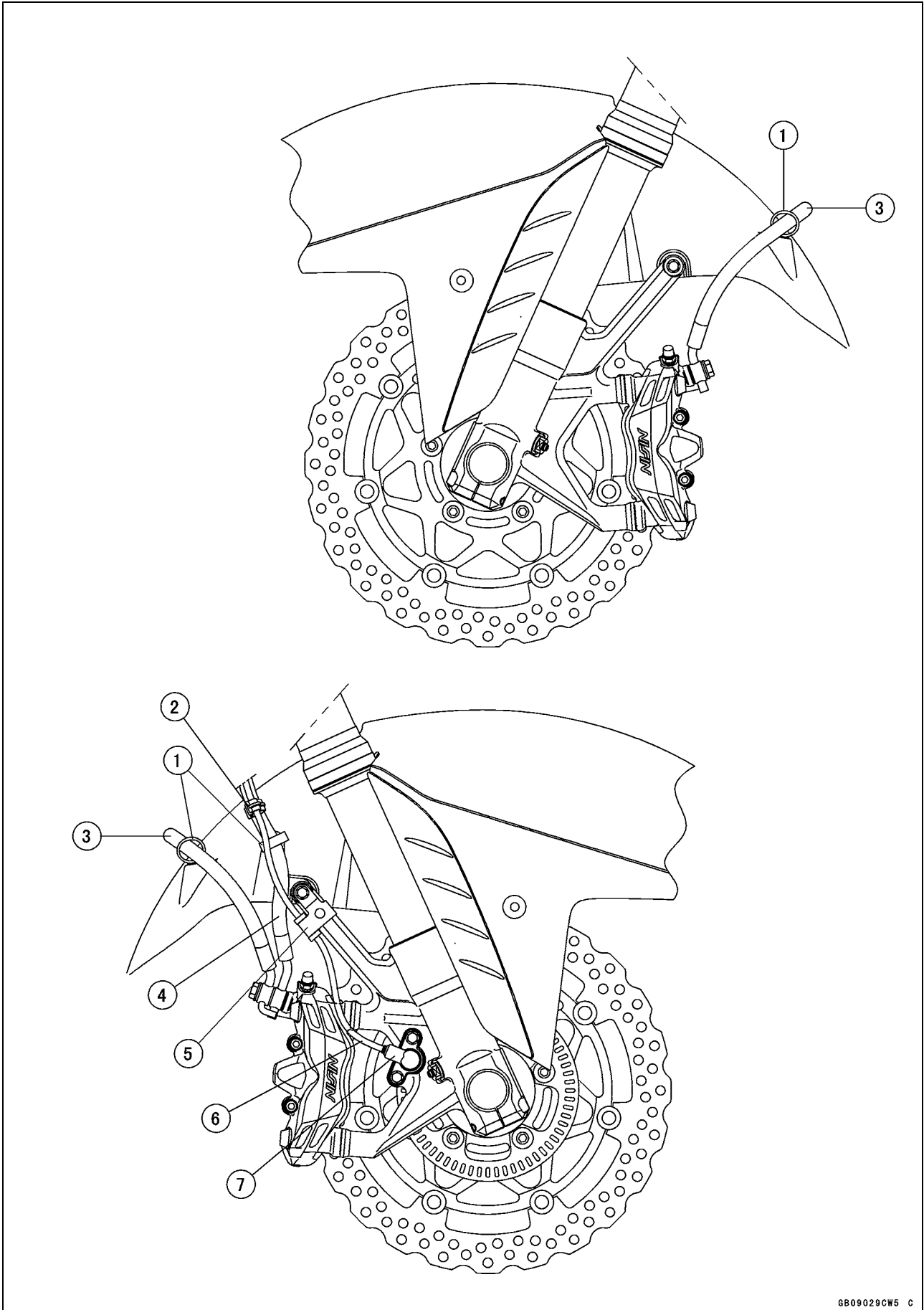

Cable, Wire, and Hose Routing

1. Clamps (Insert the clamps in the front fender.)
2. Clamp (Clamp the brake hose, and align the clamp with white tape of the front wheel rotation sensor lead.)
3. Brake Hose
4. Brake Hose (Front Master Cylinder ~ Right Front Caliper)
5. Clamp (Clamp the front wheel rotation sensor.)
6. Front Wheel Rotation Sensor Lead
7. Front Wheel Rotation Sensor

17-40 APPENDIX

Cable, Wire, and Hose Routing

ZX1400B Models

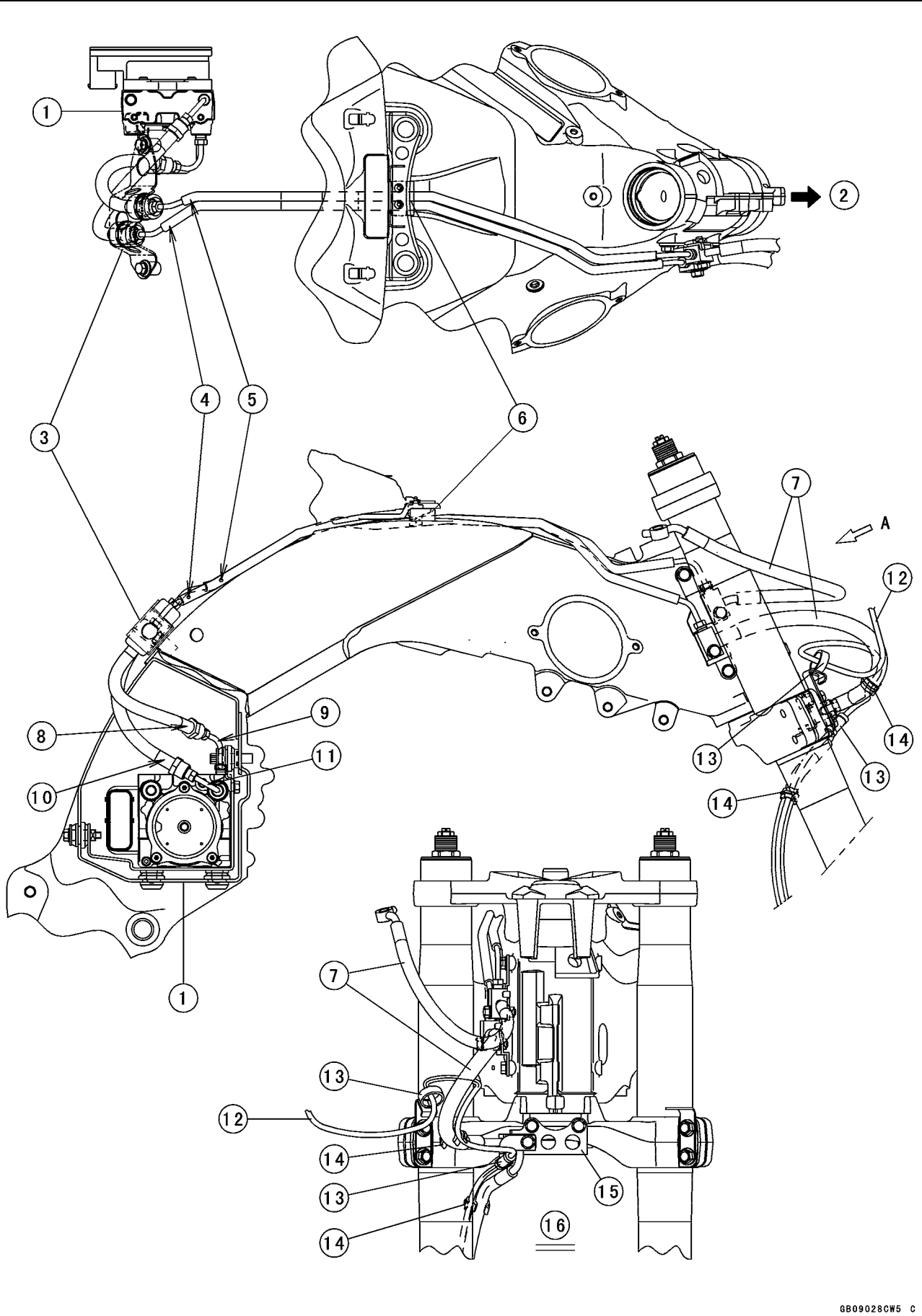

Cable, Wire, and Hose Routing

1. ABS Hydraulic Unit
2. Front
3. Bracket
4. Brake Pipe (One Blue Paint Mark)
5. Brake Pipe (One White Paint Mark)
6. Damper
7. Brake Hose
8. Brake Hose (One Blue Paint Mark)
9. Brake Hose Joint Pipe (One Blue Paint Mark)
10. Brake Hose (One White Paint Mark)
11. Brake Hose Joint Pipe (One White Paint Mark)
12. Front Wheel Rotation Sensor Lead
13. Clamps (Clamp the front wheel rotation sensor.)
14. Clamps (Clamp the brake hose, and align the clamps with white tapes of the front wheel rotation sensor lead.)
15. Bracket
16. Viewed A

17-42 APPENDIX

Cable, Wire, and Hose Routing

ZX1400B Models

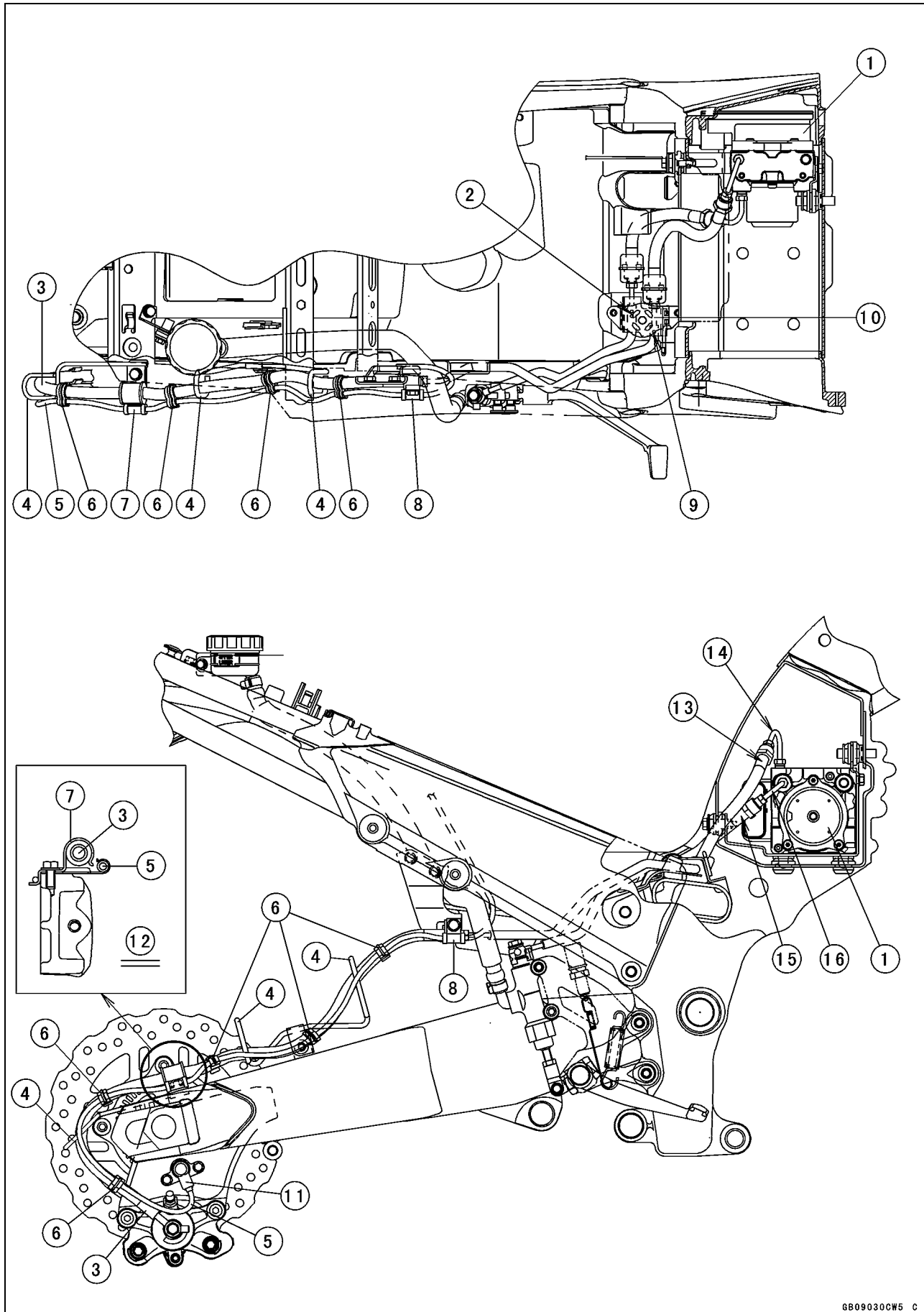

Cable, Wire, and Hose Routing

1. ABS Hydraulic Unit
2. Brake Pipe (Two White Paint Marks)
3. Brake Hose
4. Clamps (Through only the brake hose in the clamps.)
5. Rear Wheel Rotation Sensor Lead
6. Clamps (Clamp the brake hose, and align the clamps with white tape of the rear wheel rotation sensor lead.)
7. Clamp (Clamp the brake hose and rear wheel rotation sensor.)
8. Clamp (Clamp the brake hose and rear wheel rotation sensor.)
9. Brake Pipe (Two Blue Paint Marks)
10. Bracket
11. Rear Wheel Rotation Sensor
12. Viewed Rear Side
13. Brake Hose (Two Blue Paint Marks)
14. Brake Hose Joint Pipe (Two Blue Paint Marks)
15. Brake Hose (Two White Paint Marks)
16. Brake Hose Joint Pipe (One White Paint Mark)

17-44 APPENDIX

Cable, Wire, and Hose Routing

ZX1400B Models

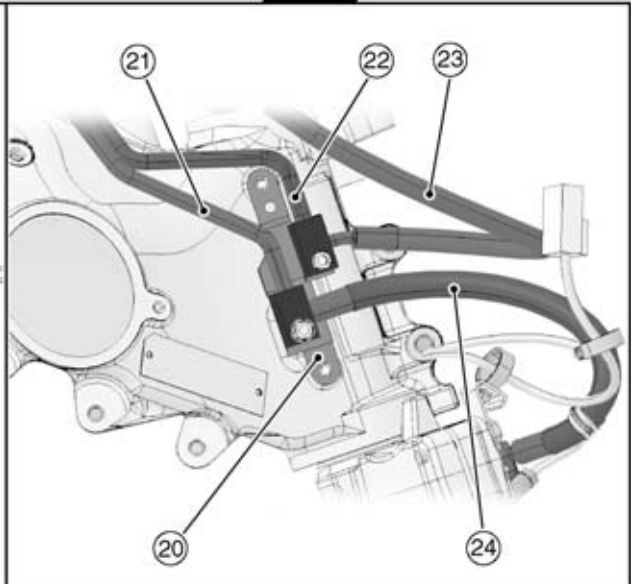
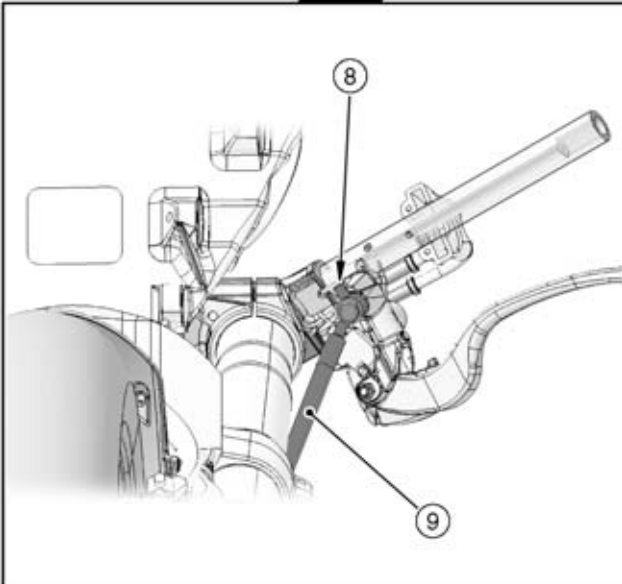
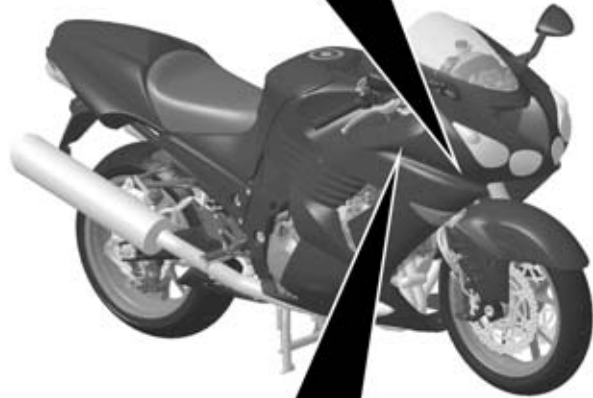
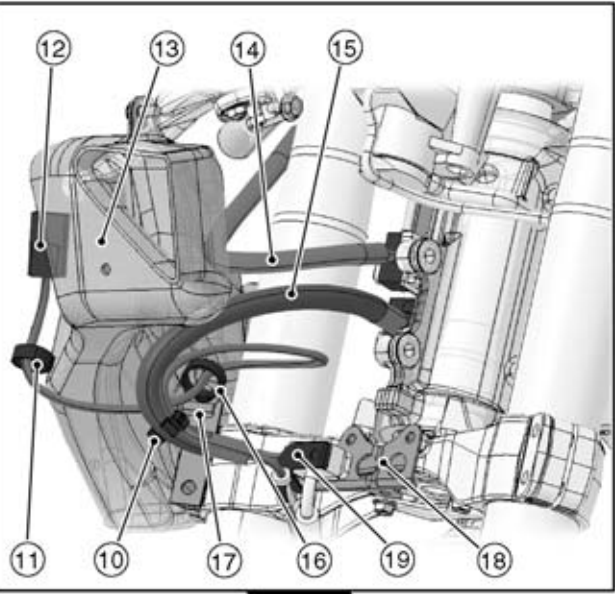
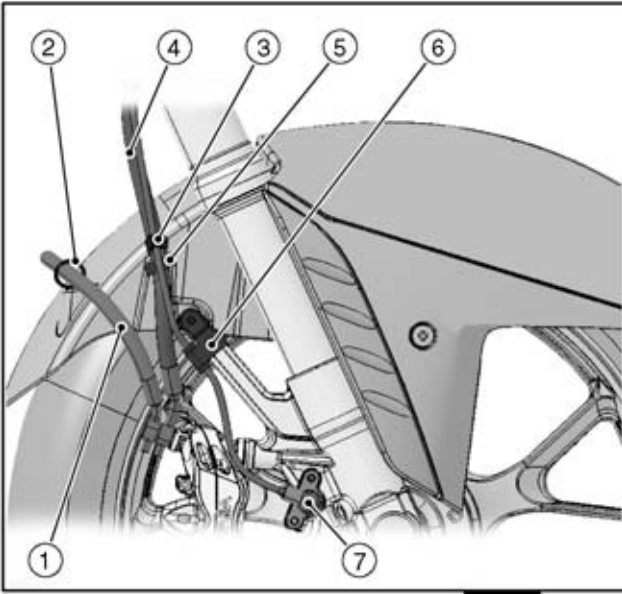

Cable, Wire, and Hose Routing

1. Brake Hose
2. Clamps (Through the brake hose in the clamp on both sides.)
3. Clamps (Clamp the brake hose, and align the clamps with white tapes of the front wheel rotation sensor lead.)
4. Brake Hose
5. Clamp (Through only the brake hose in the clamp.)
6. Clamp
7. Front Wheel Rotation Sensor
8. Install the brake hose joint as shown in the figure (face the projection of the brake hose joint backward.)
9. Brake Hose
10. Clamp (Clamp the brake hose, and align the clamp with white tape of the front wheel rotation sensor lead.)
11. Clamp
12. Front Wheel Rotation Sensor Lead Connector
13. Right Middle Air Inlet Duct
14. Brake Hose
15. Brake Hose
16. Clamp
17. Bracket
18. Bracket
19. Clamp
20. Bracket
21. Brake Pipe
22. Brake Pipe
23. Brake Hose
24. Brake Hose

17-46 APPENDIX

Cable, Wire, and Hose Routing

ZX1400B Models

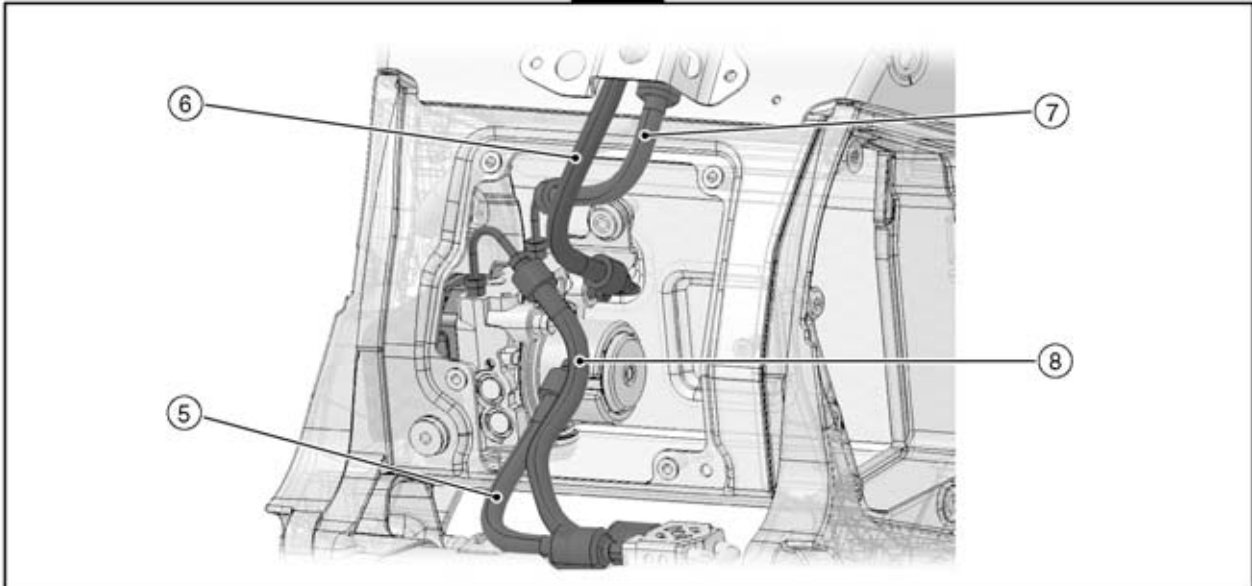
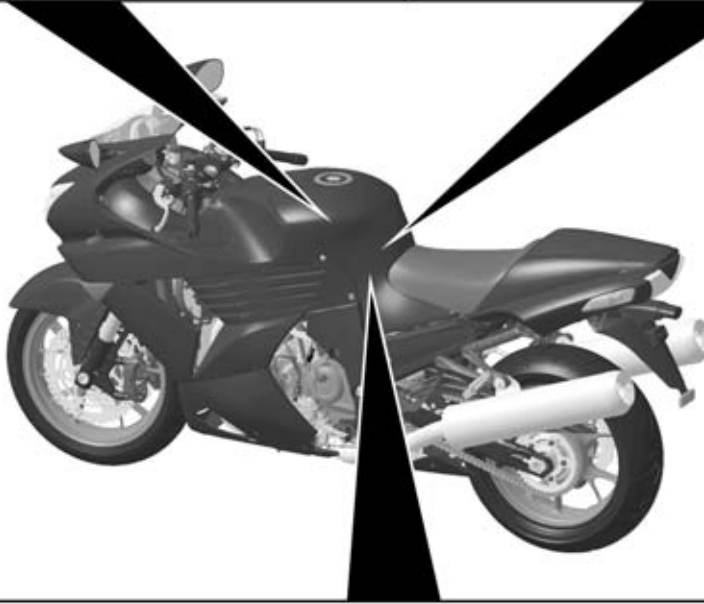
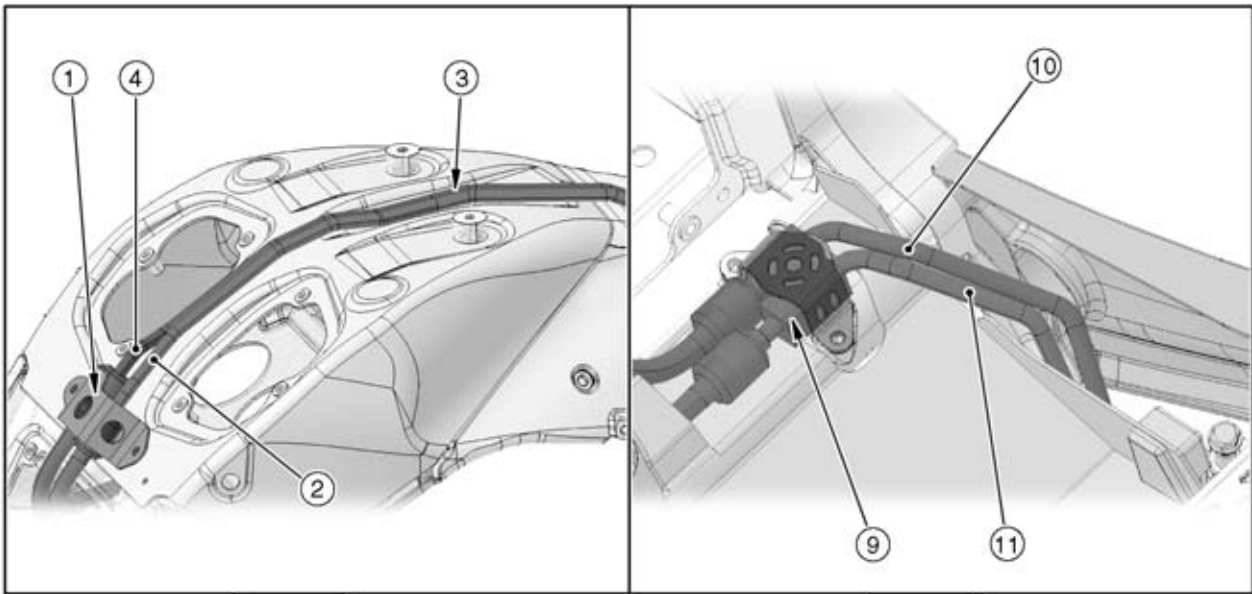

Cable, Wire, and Hose Routing

1. Bracket (Push the joint portions of the brake pipe, and clamp them.)
2. Brake Pipe (One Blue Paint Mark, ABS Hydraulic Unit Side)
3. Align the brake pipes with groove of the frame.
4. Brake Pipe (One White Paint Mark, ABS Hydraulic Unit Side)
5. Brake Hose (Two White Paint Marks) and Brake Hose Joint Pipe (One White Paint)
6. Brake Hose (One White Paint Mark) and Brake Hose Joint Pipe (One White Paint)
7. Brake Hose (One Blue Paint Mark) and Brake Hose Joint Pipe (One Blue Paint Mark)
8. Brake Hose (Two Blue Paint Marks) and Brake Hose Joint Pipe (Two Blue Paint Marks)
9. Insert the brake pipes to the holes of damper, and fit the projection of damper into the hole of bracket.
10. Brake Pipe (Two Blue Paint Marks)
11. Brake Pipe (Two White Paint Marks)

17-48 APPENDIX

Cable, Wire, and Hose Routing

ZX1400B Models

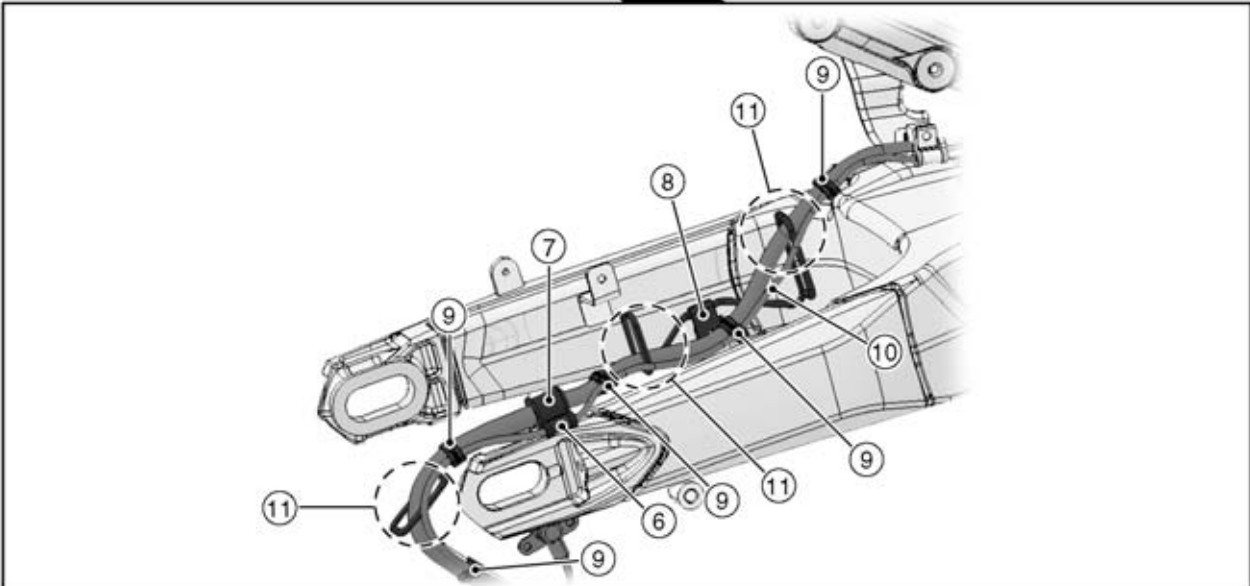
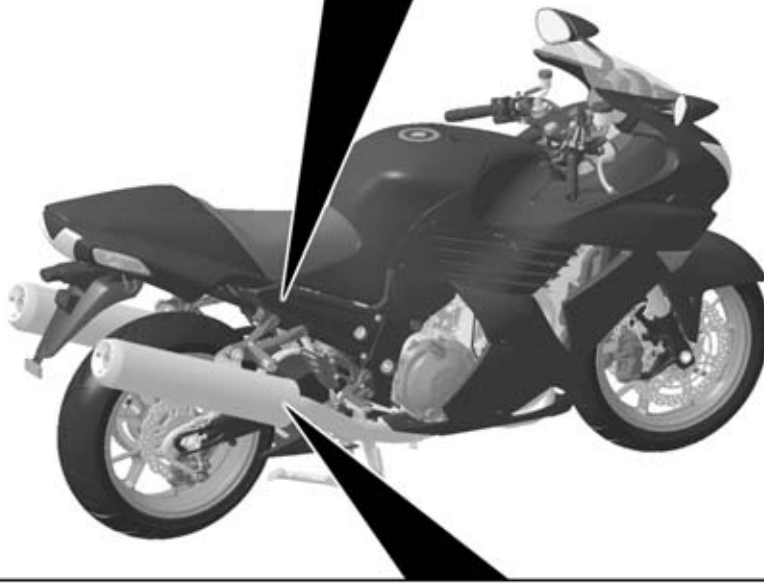
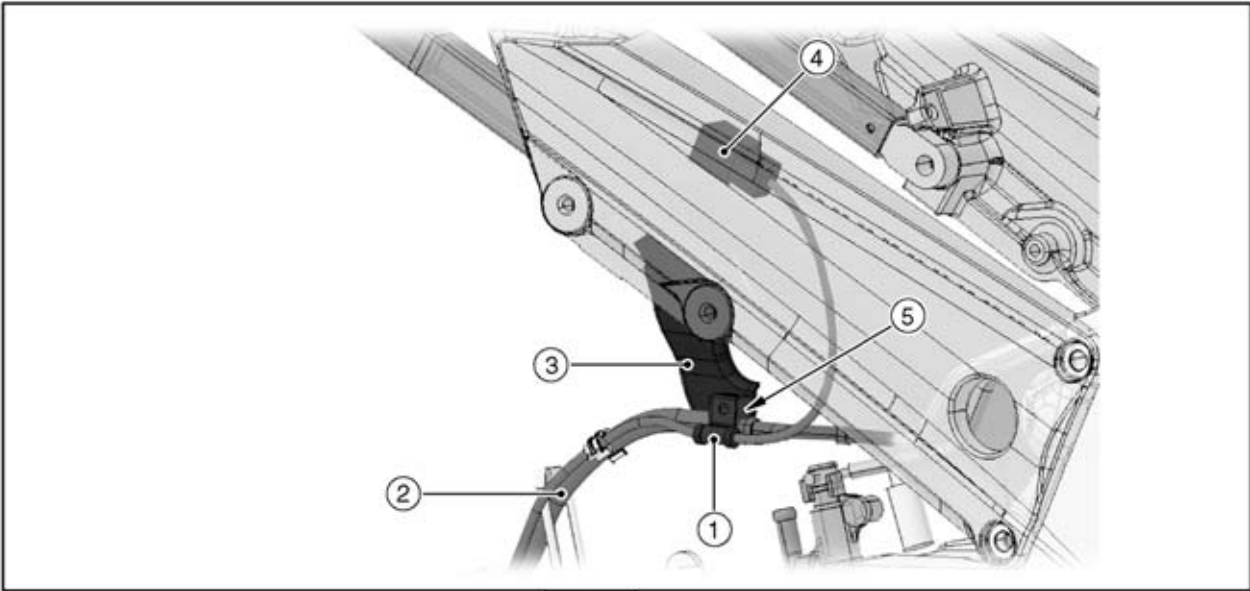

Cable, Wire, and Hose Routing

1. Clamp
2. Brake Hose
3. Bracket (Install the bracket from back of the rear frame.)
4. Rear Wheel Rotation Sensor Lead Connector
5. Clamp the joint portion of the brake hose into the bracket.
6. Clamp
7. Clamp
8. Clamp
9. Clamps (Clamp the brake hose, and align the clamps with white tape of the rear wheel rotation sensor lead.)
10. Rear Wheel Rotation Sensor Lead
11. Clamps (Through only the brake hose in the clamps.)

17-50 APPENDIX

Cable, Wire, and Hose Routing

California Model

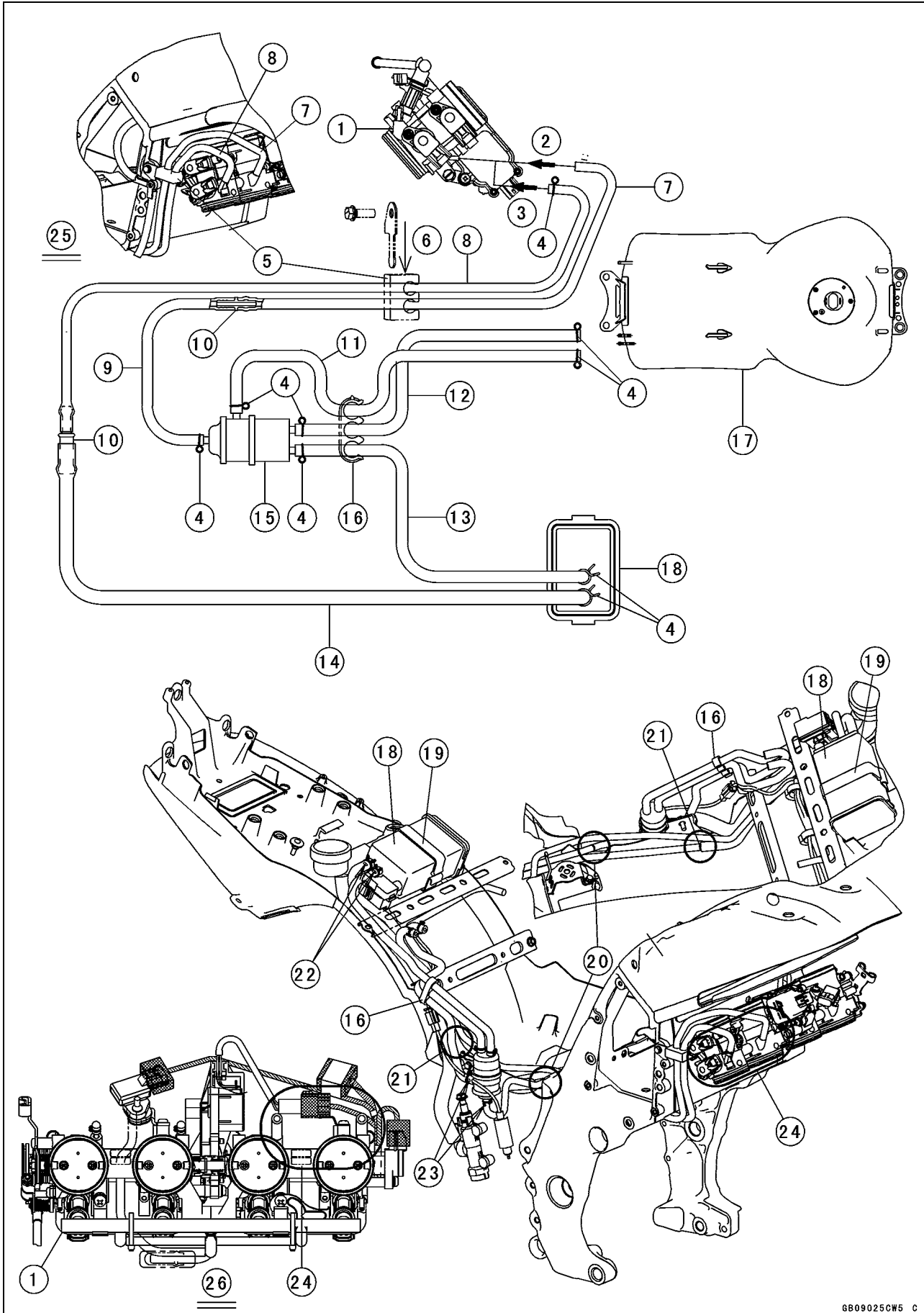

Cable, Wire, and Hose Routing

1. Throttle Body Assy
2. To the fitting of the throttle body #3.
3. To the fitting of the throttle body #4.
4. Clamps
5. Clamp
6. Insert the bracket to the holes of clamp.
7. Hose (White)
8. Hose (Green)
9. Hose (White)
10. Fittings
11. Hose (Red)
12. Hose (Blue)
13. Hose (Blue)
14. Hose (Green)
15. Separator
16. Clamp
17. Fuel Tank
18. Canister
19. Band
20. Connected position of the white hoses and fitting.
21. Connected position of the green hoses and fitting.
22. Face the paint marks upward.
23. Face the paint marks to the right side.
24. Through the hoses inside the throttle body subharness.
25. Viewed Right Side
26. Viewed Upside

17-52 APPENDIX

Troubleshooting Guide

NOTE

- Refer to the *Fuel System* chapter for most of DFI trouble shooting guide.
- This is not an exhaustive list, giving every possible cause for each problem listed. It is meant simply as a rough guide to assist the troubleshooting for some of the more common difficulties.

Engine Doesn't Start, Starting Difficulty:

Starter motor not rotating:

- Ignition and engine stop switch not ON
- Starter lockout switch or gear position switch trouble
- Starter motor trouble
- Battery voltage low
- Starter relay not contacting or operating
- Starter button not contacting
- Starter system wiring open or shorted
- Ignition switch trouble
- Engine stop switch trouble
- Main 30A or ignition fuse blown

Starter motor rotating but engine doesn't turn over:

- Vehicle-down sensor (DFI) coming off
- Immobilizer system trouble
- Starter clutch trouble
- Starter idle gear trouble

Engine won't turn over:

- Valve seizure
- Valve lifter seizure
- Cylinder, piston seizure
- Crankshaft seizure
- Connecting rod small end seizure
- Connecting rod big end seizure
- Transmission gear or bearing seizure
- Camshaft seizure
- Starter idle gear seizure
- Balancer bearing seizure

No fuel flow:

- No fuel in tank
- Fuel pump trouble
- Fuel tank air vent obstructed
- Fuel filter clogged
- Fuel line clogged

No spark; spark weak:

- Vehicle-down sensor (DFI) coming off
- Ignition switch not ON
- Engine stop switch turned OFF
- Clutch lever not pulled in or gear not in neutral
- Battery voltage low
- Immobilizer system trouble
- Spark plug dirty, broken, or gap maladjusted
- Spark plug incorrect

- Stick coil shorted or not in good contact
- Stick coil trouble
- ECU trouble
- Camshaft position sensor trouble
- Gear position, starter lockout, or side stand switch trouble
- Crankshaft sensor trouble
- Ignition switch or engine stop switch shorted
- Starter system wiring shorted or open
- Main 30A or ignition fuse blown

Fuel/air mixture incorrect:

- Bypass screw and/or idle adjusting screw maladjusted
- Air passage clogged
- Air cleaner clogged, poorly sealed, or missing
- Leak from oil filler cap, crankcase breather hose or air cleaner drain hose.

Compression Low:

- Spark plug loose
- Cylinder head not sufficiently tightened down
- Cylinder, piston worn
- Piston ring bad (worn, weak, broken, or sticking)
- Piston ring/groove clearance excessive
- Cylinder head gasket damaged
- Cylinder head warped
- Valve spring broken or weak
- No valve clearance
- Valve not seating properly (valve bent, worn, or carbon accumulation on the seating surface)

Poor Running at Low Speed:

Spark weak:

- Battery voltage low
- Immobilizer system trouble
- Stick coil trouble
- Stick coil shorted or not in good contact
- Spark plug dirty, broken, or maladjusted
- Spark plug incorrect
- ECU trouble
- Camshaft position sensor trouble
- Crankshaft sensor trouble

Fuel/air mixture incorrect:

- Bypass screw maladjusted
- Air passage clogged
- Air bleed pipe bleed holes clogged
- Pilot passage clogged
- Air cleaner clogged, poorly sealed, or missing
- Fuel tank air vent obstructed
- Fuel pump trouble
- Throttle body assy holder loose
- Air duct holder loose

Troubleshooting Guide

Compression low:

- Spark plug loose
- Cylinder head not sufficiently tightened down
- No valve clearance
- Cylinder, piston worn
- Piston ring bad (worn, weak, broken, or sticking)
- Piston ring/groove clearance excessive
- Cylinder head gasket damaged
- Cylinder head warped
- Valve spring broken or weak
- Valve not seating properly (valve bent, worn, or carbon accumulation on the seating surface)
- Camshaft cam worm

Run-on (dieseling):

- Ignition switch trouble
- Engine stop switch trouble
- Fuel injector trouble
- Loosen terminal of battery (–) cable or ECU ground lead
- Carbon accumulating on valve seating surface
- Engine overheating

Other:

- ECU trouble
- Throttle body assy not synchronizing
- Engine oil viscosity too high
- Drive train trouble
- Brake dragging
- Clutch slipping
- Engine overheating
- Air suction valve trouble
- Air switching valve trouble

Poor Running or No Power at High Speed:

Firing incorrect:

- Spark plug dirty, broken, or maladjusted
- Spark plug incorrect
- Stick coil shorted or not in good contact trouble
- Stick coil trouble
- ECU trouble

Fuel/air mixture incorrect:

- Air cleaner clogged, poorly sealed, or missing
- Air duct holder loose
- Water or foreign matter in fuel
- Throttle body assy holder loose
- Fuel to injector insufficient
- Fuel tank air vent obstructed
- Fuel line clogged
- Fuel pump trouble

Compression low:

- Spark plug loose

- Cylinder head not sufficiently tightened down
- No valve clearance
- Cylinder, piston worn
- Piston ring bad (worn, weak, broken, or sticking)
- Piston ring/groove clearance excessive
- Cylinder head gasket damaged
- Cylinder head warped
- Valve spring broken or weak
- Valve not seating properly (valve bent, worn, or carbon accumulation on the seating surface.)

Knocking:

- Carbon built up in combustion chamber
- Fuel poor quality or incorrect
- Spark plug incorrect
- ECU trouble

Miscellaneous:

- Throttle valve won't fully open
- Brake dragging
- Clutch slipping
- Engine overheating
- Engine oil level too high
- Engine oil viscosity too high
- Drive train trouble
- Camshaft cam worm
- Air suction valve trouble
- Air switching valve trouble
- Catalytic converter melt down due to muffler overheating (KLEEN)

Overheating:

Firing incorrect:

- Spark plug dirty, broken, or maladjusted
- Spark plug incorrect
- ECU trouble

Muffler overheating:

- For KLEEN, do not run the engine even if with only one cylinder misfiring or poor running (Request the nearest service facility to correct it)
- For KLEEN, do not push-start with a dead battery (Connect another full-charged battery with jumper cables, and start the engine using the electric starter)
- For KLEEN, do not start the engine under misfire due to spark plug fouling or poor connection of the stick coil
- For KLEEN, do not coast the motorcycle with the ignition switch off (Turn the ignition switch ON and run the engine)
- ECU trouble

Fuel/air mixture incorrect:

- Throttle body assy holder loose
- Air duct holder loose
- Air cleaner poorly sealed, or missing

17-54 APPENDIX

Troubleshooting Guide

Air cleaner clogged

Compression high:

Carbon built up in combustion chamber

Engine load faulty:

Clutch slipping

Engine oil level too high

Engine oil viscosity too high

Drive train trouble

Brake dragging

Lubrication inadequate:

Engine oil level too low

Engine oil poor quality or incorrect

Oil cooler incorrect:

Oil cooler clogged

Gauge incorrect:

Water temperature gauge broken

Water temperature sensor broken

Coolant incorrect:

Coolant level too low

Coolant deteriorated

Wrong coolant mixed ratio

Cooling system component incorrect:

Radiator fin damaged

Radiator clogged

Thermostat trouble

Radiator cap trouble

Radiator fan relay trouble

Fan motor broken

Fan blade damaged

Water pump not turning

Water pump impeller damaged

Over Cooling:

Gauge incorrect:

Water temperature gauge broken

Water temperature sensor broken

Cooling system component incorrect:

Thermostat trouble

Clutch Operation Faulty:

Clutch slipping:

Friction plate worn or warped

Steel plate worn or warped

Clutch spring broken or weak

Clutch hub or housing unevenly worn

Clutch master cylinder trouble

Clutch slave cylinder trouble

Clutch not disengaging properly:

Clutch plate warped or too rough

Clutch spring compression uneven

Engine oil deteriorated

Engine oil viscosity too high

Engine oil level too high

Clutch housing frozen on drive shaft

Clutch hub nut loose

Clutch hub spline damaged

Clutch friction plate installed wrong

Clutch slave cylinder trouble

Clutch fluid deteriorated

Air in clutch fluid line

Clutch master cylinder primary or secondary cup damage

Clutch master cylinder scratched inside

Gear Shifting Faulty:

Doesn't go into gear; shift pedal doesn't return:

Clutch not disengaging

Shift fork bent or seized

Gear stuck on the shaft

Gear positioning lever binding

Shift return spring weak or broken

Shift return spring pin loose

Shift mechanism arm spring broken

Shift mechanism arm broken

Shift pawl broken

Jumps out of gear:

Shift fork ear worn, bent

Gear groove worn

Gear dogs and/or dog holes worn

Shift drum groove worn

Gear positioning lever spring weak or broken

Shift fork guide pin worn

Drive shaft, output shaft, and/or gear splines worn

Overshifts:

Gear positioning lever spring weak or broken

Shift mechanism arm spring broken

Abnormal Engine Noise:

Knocking:

ECU trouble

Carbon built up in combustion chamber

Fuel poor quality or incorrect

Spark plug incorrect

Overheating

Piston slap:

Cylinder/piston clearance excessive

Cylinder, piston worn

Connecting rod bent

Piston pin, piston pin hole worn

Valve noise:

Valve clearance incorrect

Valve spring broken or weak

Camshaft bearing worn

Valve lifter worn

Other noise:

Connecting rod small end clearance excessive

Connecting rod big end clearance excessive

Piston ring/groove clearance excessive

Troubleshooting Guide

Piston ring worn, broken, or stuck
 Piston ring groove worn
 Piston seizure, damage
 Cylinder head gasket leaking
 Exhaust pipe leaking at cylinder head connection
 Crankshaft runout excessive
 Engine mount loose
 Crankshaft bearing worn
 Primary gear worn or chipped
 Camshaft chain tensioner trouble
 Camshaft chain, sprocket, guide worn
 Air suction valve damaged
 Air switching valve damaged
 Alternator rotor loose
 Catalytic converter melt down due to muffler overheating (KLEEN)

Abnormal Drive Train Noise:

Clutch noise:

Clutch damper weak or damaged
 Clutch housing/friction plate clearance excessive
 Clutch housing gear worn
 Wrong installation of outside friction plate

Transmission noise:

Bearings worn
 Transmission gear worn or chipped
 Metal chips jammed in gear teeth
 Engine oil insufficient

Drive line noise:

Drive chain adjusted improperly
 Drive chain worn
 Rear and/or engine sprocket worn
 Chain lubrication insufficient
 Rear wheel misaligned

Abnormal Frame Noise:

Front fork noise:

Oil insufficient or too thin
 Spring weak or broken

Rear shock absorber noise:

Shock absorber damaged

Disc brake noise:

Pad installed incorrectly
 Pad surface glazed
 Disc warped
 Caliper trouble

Other noise:

Bracket, nut, bolt, etc. not properly mounted or tightened

Oil Pressure Warning Light Goes On:

Engine oil pump damaged
 Engine oil screen clogged
 Engine oil filter clogged

Engine oil level too low
 Engine oil viscosity too low
 Camshaft bearing worn
 Crankshaft bearing worn
 Oil pressure switch damaged
 Wiring faulty
 Relief valve stuck open
 O-ring at the oil passage in the crankcase damaged

Exhaust Smokes Excessively:

White smoke:

Piston oil ring worn
 Cylinder worn
 Valve oil seal damaged
 Valve guide worn
 Engine oil level too high

Black smoke:

Air cleaner clogged

Brown smoke:

Air duct holder loose
 Air cleaner poorly sealed or missing

Handling and/or Stability Unsatisfactory:

Handlebar hard to turn:

Cable routing incorrect
 Hose routing incorrect
 Wiring routing incorrect
 Steering stem nut too tight
 Steering stem bearing damaged
 Steering stem bearing lubrication inadequate
 Steering stem bent
 Tire air pressure too low

Handlebar shakes or excessively vibrates:

Tire worn
 Swingarm pivot bearing worn
 Rim warped, or not balanced
 Wheel bearing worn
 Handlebar holder bolt loose
 Steering stem nut loose
 Front, rear axle runout excessive
 Engine mounting bolt loose

Handlebar pulls to one side:

Frame bent
 Wheel misalignment
 Swingarm bent or twisted
 Swingarm pivot shaft runout excessive
 Steering maladjusted
 Front fork bent
 Right and left front fork oil level uneven

Shock absorption unsatisfactory:

(Too hard)
 Front fork oil excessive
 Front fork oil viscosity too high
 Rear shock absorber adjustment too hard

17-56 APPENDIX

Troubleshooting Guide

- Tire air pressure too high
- Front fork bent
- (Too soft)
- Tire air pressure too low
- Front fork oil insufficient and/or leaking
- Front fork oil viscosity too low
- Rear shock adjustment too soft
- Front fork, rear shock absorber spring weak
- Rear shock absorber oil leaking

Brake Doesn't Hold:

- Air in the brake line
- Pad or disc worn
- Brake fluid leakage
- Disc warped
- Contaminated pad
- Brake fluid deteriorated
- Primary or secondary cup damaged in master cylinder
- Master cylinder scratched inside

Battery Trouble:

Battery discharged:

- Charge insufficient
- Battery faulty (too low terminal voltage)
- Battery cable making poor contact
- Load excessive (e.g., bulb of excessive wattage)
- Ignition switch trouble
- Alternator trouble
- Wiring faulty
- Regulator/rectifier trouble

Battery overcharged:

- Alternator trouble
- Regulator/rectifier trouble
- Battery faulty

MODEL APPLICATION

Year	Model	Beginning Frame No.
2006	ZX1400A6F	JKBZXNA1□6A000001 JKBZXT40AAA000001 ZXT40A-000001
2006	ZX1400B6F	JKBZXT40ABA000001 ZXT40B-000001

□:This digit in the frame number changes from one machine to another.



KAWASAKI HEAVY INDUSTRIES, LTD.
Consumer Products & Machinery Company

Part No.99924-1362-01

Printed in Japan